

NOW LEAD-FREE!

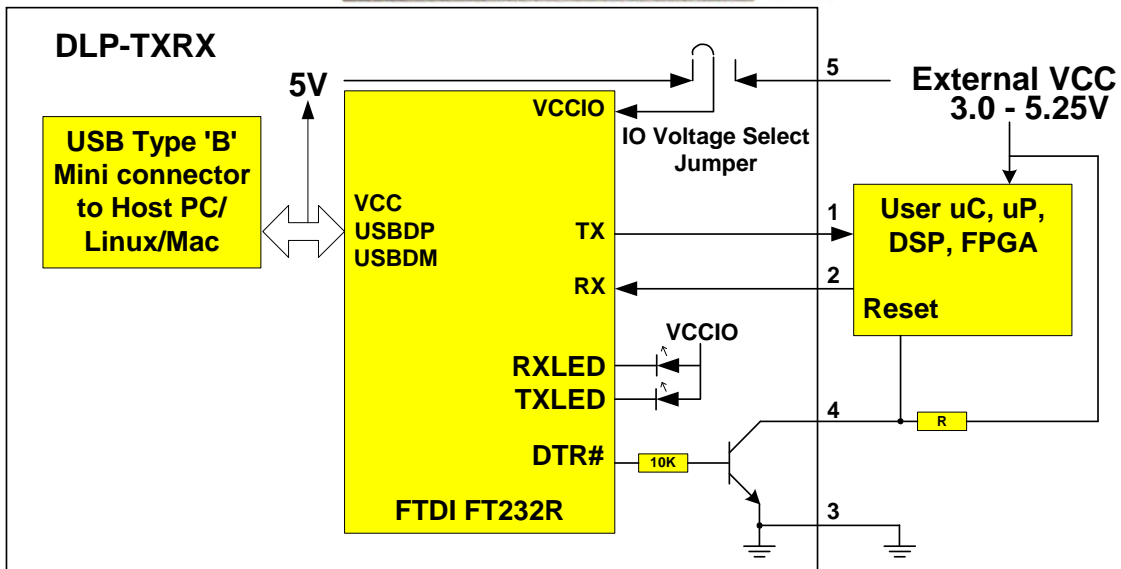

1.0 Introduction

The DLP-TXRX-G USB-to-serial adapter is designed to easily connect a microcontroller/DSP/FPGA/etc to a host PC; or upgrade a legacy RS232 device to USB via a 2-wire serial interface with minimal design effort. Virtual COM Port (VCP) drivers are provided royalty-free that make the DLP-TXRX-G look like a standard Windows/Linux/Mac RS232 port to the user's host program.

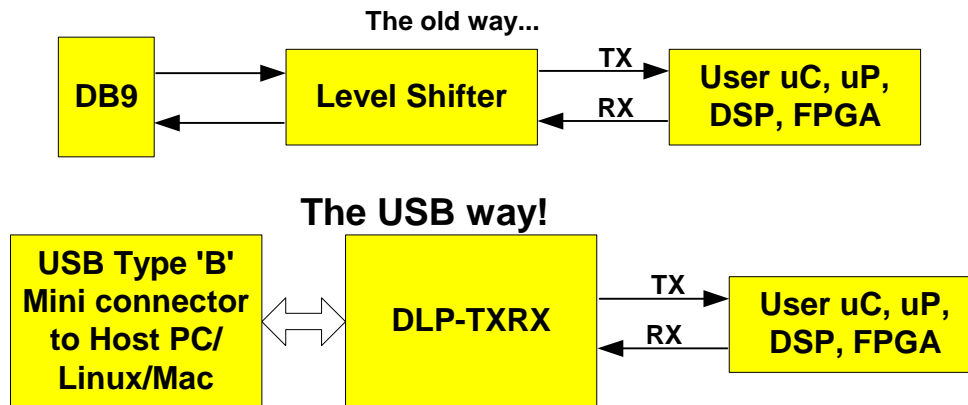

1.1 Features Summary

- Royalty-free Virtual COM Port drivers

VIRTUAL COM PORT (VCP) DRIVER SUPPORT FOR:

- Windows 98 / 98 SE / 2000 / ME / XP
 - Windows CE
 - MAC OS-8 and OS-9
 - MAC OS-X
 - Linux 2.40 and greater
-
- As few as 2 wire serial interface (RX, TX and ground)
 - Standard baud rates from 300 to 921,600 baud
 - Support for non-standard baud rates
 - One open-collector output (pin 4): can be used for resetting microcontroller under software control (DTR)
 - Input provided (pin 5) for user-selectable interface voltage
 - Red and green LEDs to indicate transmit and receive activity
 - USB 2.0 interface compatible
 - USB Description strings, VID and PID configurable in on-chip EEPROM
 - EEPROM Configurable in-circuit via USB
 - Support for the RS232 BREAK setting and detection conditions

1.2 General Description

All operational power for the DLP-TXRX-G is taken from the host PC USB port or upstream hub. All power required by user electronics must be provided by external power supply.

FTDI provides a royalty free Virtual COM Port (VCP) driver that makes this USB device appear as a standard COM port to the PC. Most existing software applications should be able interface with the Virtual COM Port simply by reconfiguring them to use the new COM ports created by the driver. Using the VCP drivers, an application program would communicate with the DLP-TXRX-G in exactly the same way as it would a regular RS232 COM port - using the Windows VCOMM API calls or a COM port library.

Also available is a DLL version of the drivers that allows application programmers to interface software directly to the device using a Windows DLL. Both the VCP and DLL version of the drivers are available for download from both the dlpdesign.com and ftdichip.com web sites.

The on-chip EEPROM can be used to customize the USB VID, PID, Serial Number, Product Description Strings and Power Descriptor value of the DLP-RXTX-G for OEM applications. The EEPROM is programmable in-circuit via USB using a utility program (MPROG) available from both www.ftdichip.com and www.dlpdesign.com.

1.3 DTR Open Collector Output

Pin 4 of the DLP-TXRX-G is an open-collector output that is controlled by the DTR# output of the FT232RL. Upon power up of the DLP-TXRX-G (i.e. when connected to the host PC), pin 4 is initially driven low via an open-collector transistor until the host application opens the COM port that the DLP-TXRX-G is assigned to. Once the port is opened, pin 4 becomes high-impedance. From this point forward, the state of pin 4 can be changed under software control via the user's application program by setting and clearing DTR#.

NOTE: if pin 4 is used to reset an external microcontroller, then upon power up the processor will not run until the COM port is opened by the host application.

1.4 VCCIO Input

Pin 5 is used to provide power to the I/O pins of the FT232RL in instances where the external microcontroller/DSP/FPGA/etc is operating at a voltage other than 5 volts. The acceptable input voltage range on Pin 5 is 1.8 to 5.25 volts. If the external processor is running at 5.0 volts then Pin 5 can be left disconnected.

If the external processor is running at a voltage other than 5 volts then the solder bridge at location '5' on the DLP-TXRX-G pcb must be removed and a solder bridge at location '3' must be applied in order for the voltage applied to pin 5 to be used.

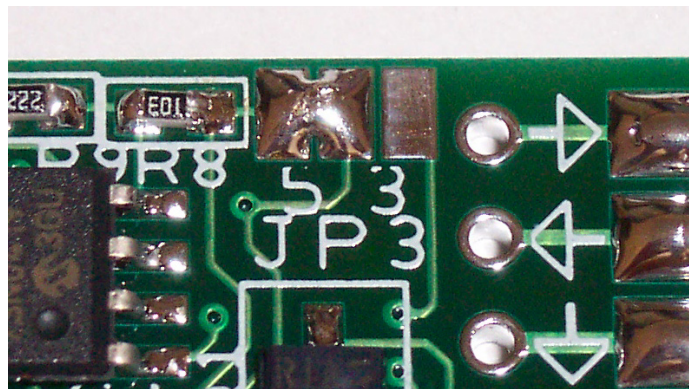

1.5 Activity LEDs

Transmit and receive LEDs are provided to indicate activity. When data is being transmitted or received, the respective LEDs illuminate in order to provide indication of data transfer. Circuitry in the FT232RL ensures that even a small percentage of data transfer is visible to the end user.

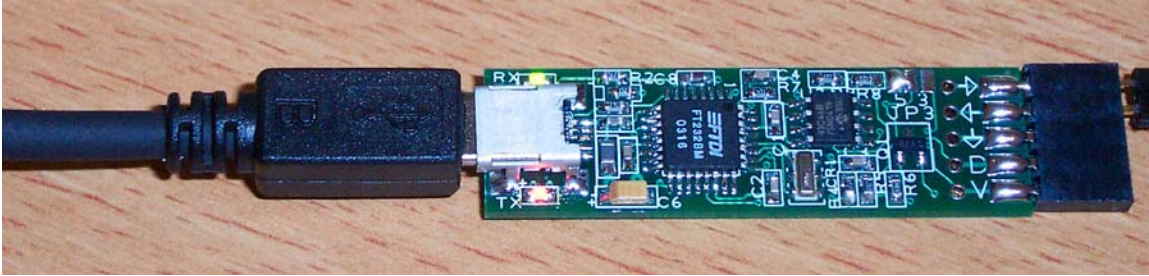

2.0 Mechanical Dimensions >>> Preliminary <<<
Inches (mm)

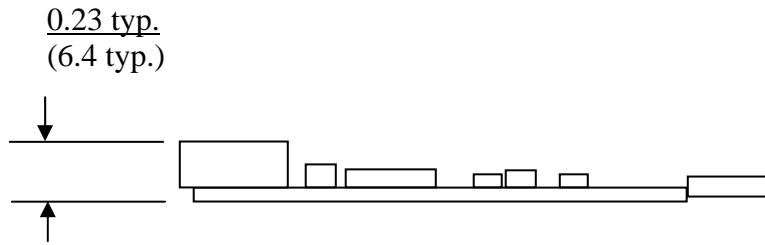
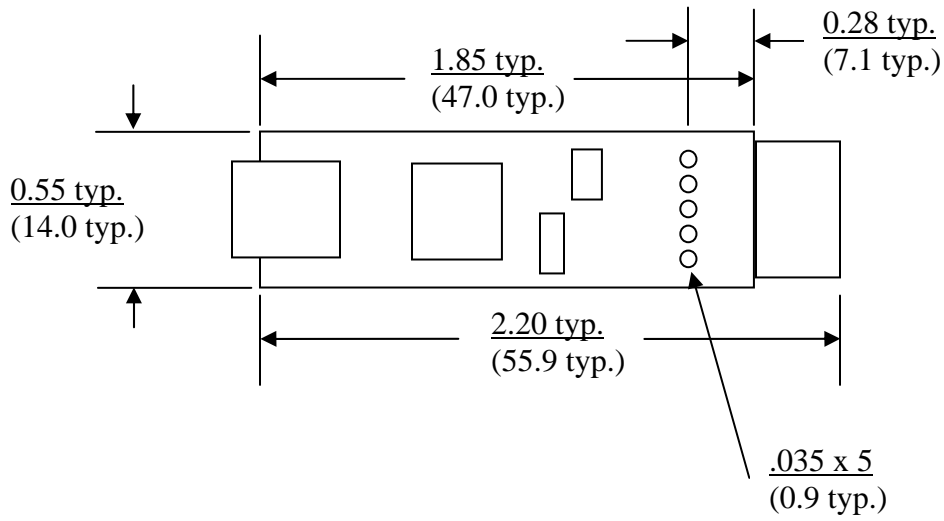

3.0 Disclaimer

© DLP Design, Inc., 2002 / 2008

Neither the whole nor any part of the information contained in, or the product described in this manual, may be adapted or reproduced in any material or electronic form without the prior written consent of the copyright holder.

This product and its documentation are supplied on an as-is basis and no warranty as to their suitability for any particular purpose is either made or implied. DLP Design, Inc. will not accept any claim for damages howsoever arising as a result of use or failure of this product. Your statutory rights are not affected. This product or any variant of it is not intended for use in any medical appliance, device or system in which the failure of the product might reasonably be expected to result in personal injury.

This document provides preliminary information that may be subject to change without notice.

4.0 Contact Information

DLP Design, Inc.
1605 Roma Lane
Allen, TX 75013

Phone: 469-964-8027
Fax: 415-901-4859

E-Mail (Sales) : sales@dlpdesign.com
E-Mail (Support) : support@dlpdesign.com
Web Site URL : <http://www.dlpdesign.com>

DLP-TXRX-G

3 External 1.8 - 5.25V
 JP3
 5 5.0V From USB Port (default)

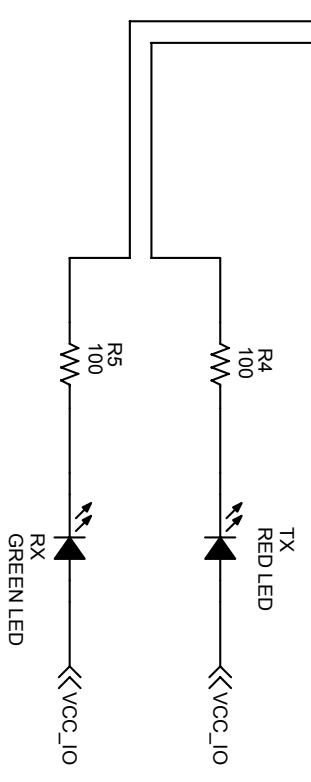
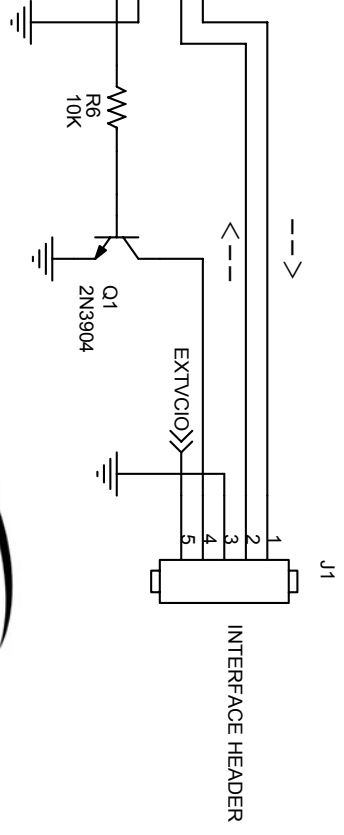
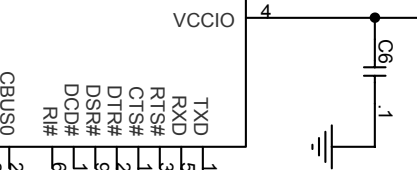
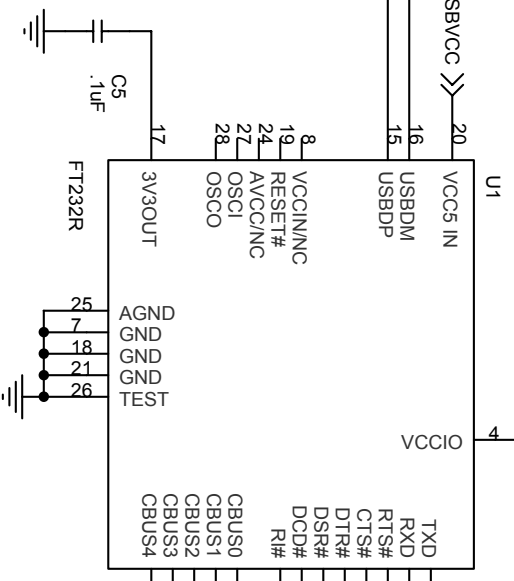
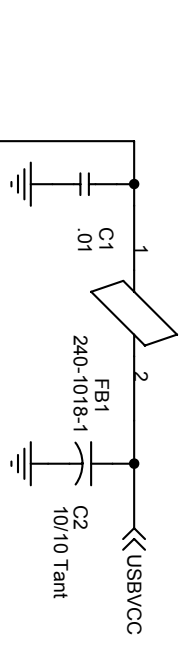

5 4 3 2 1

A B C D



Стандарт Электрон Связь

Мы молодая и активно развивающаяся компания в области поставок электронных компонентов. Мы поставляем электронные компоненты отечественного и импортного производства напрямую от производителей и с крупнейших складов мира.

Благодаря сотрудничеству с мировыми поставщиками мы осуществляем комплексные и плановые поставки широчайшего спектра электронных компонентов.

Собственная эффективная логистика и склад в обеспечивает надежную поставку продукции в точно указанные сроки по всей России.

Мы осуществляем техническую поддержку нашим клиентам и предпродажную проверку качества продукции. На все поставляемые продукты мы предоставляем гарантию .

Осуществляем поставки продукции под контролем ВП МО РФ на предприятия военно-промышленного комплекса России , а также работаем в рамках 275 ФЗ с открытием отдельных счетов в уполномоченном банке. Система менеджмента качества компании соответствует требованиям ГОСТ ISO 9001.

Минимальные сроки поставки, гибкие цены, неограниченный ассортимент и индивидуальный подход к клиентам являются основой для выстраивания долгосрочного и эффективного сотрудничества с предприятиями радиоэлектронной промышленности, предприятиями ВПК и научно-исследовательскими институтами России.

С нами вы становитесь еще успешнее!

Наши контакты:

Телефон: +7 812 627 14 35

Электронная почта: sales@st-electron.ru

Адрес: 198099, Санкт-Петербург,
Промышленная ул, дом № 19, литера Н,
помещение 100-Н Офис 331