

S29AL008D

**8 Megabit (1M x 8-Bit/512 K x 16-Bit)
CMOS 3.0 Volt-only Boot Sector Flash Memory**

Data Sheet



This product has been retired and is not recommended for designs. For new and current designs, S29AL008J supercedes S29AL008D. This is the factory-recommended migration path. Please refer to the S29AL008J data sheet for specifications and ordering information.

Availability of this document is retained for reference and historical purposes only.

Notice to Readers: This document states the current technical specifications regarding the Spansion product(s) described herein. Each product described herein may be designated as Advance Information, Preliminary, or Full Production. See *Notice On Data Sheet Designations* for definitions.

Notice On Data Sheet Designations

Spansion Inc. issues data sheets with Advance Information or Preliminary designations to advise readers of product information or intended specifications throughout the product life cycle, including development, qualification, initial production, and full production. In all cases, however, readers are encouraged to verify that they have the latest information before finalizing their design. The following descriptions of Spansion data sheet designations are presented here to highlight their presence and definitions.

Advance Information

The Advance Information designation indicates that Spansion Inc. is developing one or more specific products, but has not committed any design to production. Information presented in a document with this designation is likely to change, and in some cases, development on the product may discontinue. Spansion Inc. therefore places the following conditions upon Advance Information content:

“This document contains information on one or more products under development at Spansion Inc. The information is intended to help you evaluate this product. Do not design in this product without contacting the factory. Spansion Inc. reserves the right to change or discontinue work on this proposed product without notice.”

Preliminary

The Preliminary designation indicates that the product development has progressed such that a commitment to production has taken place. This designation covers several aspects of the product life cycle, including product qualification, initial production, and the subsequent phases in the manufacturing process that occur before full production is achieved. Changes to the technical specifications presented in a Preliminary document should be expected while keeping these aspects of production under consideration. Spansion places the following conditions upon Preliminary content:

“This document states the current technical specifications regarding the Spansion product(s) described herein. The Preliminary status of this document indicates that product qualification has been completed, and that initial production has begun. Due to the phases of the manufacturing process that require maintaining efficiency and quality, this document may be revised by subsequent versions or modifications due to changes in technical specifications.”

Combination

Some data sheets contain a combination of products with different designations (Advance Information, Preliminary, or Full Production). This type of document distinguishes these products and their designations wherever necessary, typically on the first page, the ordering information page, and pages with the DC Characteristics table and the AC Erase and Program table (in the table notes). The disclaimer on the first page refers the reader to the notice on this page.

Full Production (No Designation on Document)

When a product has been in production for a period of time such that no changes or only nominal changes are expected, the Preliminary designation is removed from the data sheet. Nominal changes may include those affecting the number of ordering part numbers available, such as the addition or deletion of a speed option, temperature range, package type, or V_{IO} range. Changes may also include those needed to clarify a description or to correct a typographical error or incorrect specification. Spansion Inc. applies the following conditions to documents in this category:

“This document states the current technical specifications regarding the Spansion product(s) described herein. Spansion Inc. deems the products to have been in sufficient production volume such that subsequent versions of this document are not expected to change. However, typographical or specification corrections, or modifications to the valid combinations offered may occur.”

Questions regarding these document designations may be directed to your local sales office.

S29AL008D

8 Megabit (1M x 8-Bit/512 K x 16-Bit) CMOS 3.0 Volt-only Boot Sector Flash Memory



Data Sheet

This product has been retired and is not recommended for designs. For new and current designs, S29AL008J supercedes S29AL008D. This is the factory-recommended migration path. Please refer to the S29AL008J data sheet for specifications and ordering information.

Distinctive Characteristics

Architectural Advantage

- **Single Power Supply Operation**
 - 2.7 to 3.6 volt read and write operations for battery-powered applications
- **Manufactured on 200 nm Process Technology**
 - Compatible with 0.32 μm and 230 nm Am29LV800 devices
- **Flexible Sector Architecture**
 - One 16-Kbyte, two 8-Kbyte, one 32-Kbyte, and fifteen 64-Kbyte sectors (byte mode)
 - One 8 Kword, two 4 Kword, one 16-Kword, and fifteen 32-Kword sectors (word mode)
 - Supports full chip erase
 - Sector Protection features:
 - A hardware method of locking a sector to prevent any program or erase operations within that sector
 - Sectors can be locked in-system or via programming equipment
 - Temporary Sector Unprotect feature allows code changes in previously locked sectors
- **Unlock Bypass Program Command**
 - Reduces overall programming time when issuing multiple program command sequences
- **Top or Bottom Boot Block Configurations Available**
- **Embedded Algorithms**
 - Embedded Erase algorithm automatically preprograms and erases the entire chip or any combination of designated sectors
 - Embedded Program algorithm automatically writes and verifies data at specified addresses
- **Compatibility with JEDEC Standards**
 - Pinout and software compatible with single-power supply Flash
 - Superior inadvertent write protection

Performance Characteristics

- **High Performance**
 - Access times as fast as 55 ns
 - Extended temperature range (-40°C to +125°C)
- **Ultra-low Power Consumption (typical values at 5 MHz)**
 - 200 nA Automatic Sleep mode current
 - 200 nA standby mode current
 - 7 mA read current
 - 15 mA program/erase current
- **Cycling Endurance: 1,000,000 cycles per sector typical**
- **Data Retention: 20 years typical**
 - Reliable operation for the life of the system

Package Option

- 48-ball FBGA
- 48-pin TSOP
- 44-pin SO

Software Features

- **Data# Polling and Toggle Bits**
 - Provides a software method of detecting program or erase operation completion
- **Erase Suspend/Erase Resume**
 - Suspends an erase operation to read data from, or program data to, a sector that is not being erased, then resumes the erase operation

Hardware Features

- **Ready/Busy# Pin (RY/BY#)**
 - Provides a hardware method of detecting program or erase cycle completion
- **Hardware Reset Pin (RESET#)**
 - Hardware method to reset the device to reading array data

General Description

The S29AL008D is an 8 Mbit, 3.0 volt-only Flash memory organized as 1,048,576 bytes or 524,288 words. The device is offered in 48-ball FBGA, 44-pin SO, and 48-pin TSOP packages. For more information, refer to publication number 21536. The word-wide data (x16) appears on DQ15–DQ0; the byte-wide (x8) data appears on DQ7–DQ0. This device requires only a single, 3.0 volt V_{CC} supply to perform read, program, and erase operations. A standard EPROM programmer can also be used to program and erase the device.

This device is manufactured using Spansion's 200 nm process technology, and offers all the features and benefits of the Am29LV800B, which was manufactured using 0.32 μm process technology.

The standard device offers access times of 55, 60, 70, and 90 ns, allowing high speed microprocessors to operate without wait states. To eliminate bus contention the device contains separate chip enable (CE#), write enable (WE#) and output enable (OE#) controls.

The device requires only a **single 3.0 volt power supply** for both read and write functions. Internally generated and regulated voltages are provided for the program and erase operations.

The device is entirely command set compatible with the **JEDEC single-power-supply Flash standard**. Commands are written to the command register using standard microprocessor write timings. Register contents serve as input to an internal state-machine that controls the erase and programming circuitry. Write cycles also internally latch addresses and data needed for the programming and erase operations. Reading data out of the device is similar to reading from other Flash or EPROM devices.

Device programming occurs by executing the program command sequence. This initiates the **Embedded Program** algorithm—an internal algorithm that automatically times the program pulse widths and verifies proper cell margin. The **Unlock Bypass** mode facilitates faster programming times by requiring only two write cycles to program data instead of four.

Device erasure occurs by executing the erase command sequence. This initiates the **Embedded Erase** algorithm—an internal algorithm that automatically preprograms the array (if it is not already programmed) before executing the erase operation. During erase, the device automatically times the erase pulse widths and verifies proper cell margin.

The host system can detect whether a program or erase operation is complete by observing the RY/BY# pin, or by reading the DQ7 (Data# Polling) and DQ6 (toggle) **status bits**. After a program or erase cycle is completed, the device is ready to read array data or accept another command.

The **sector erase architecture** allows memory sectors to be erased and reprogrammed without affecting the data contents of other sectors. The device is fully erased when shipped from the factory.

Hardware data protection measures include a low V_{CC} detector that automatically inhibits write operations during power transitions. The **hardware sector protection** feature disables both program and erase operations in any combination of the sectors of memory. This can be achieved in-system or via programming equipment.

The **Erase Suspend** feature enables the user to put erase on hold for any period of time to read data from, or program data to, any sector that is not selected for erasure. True background erase can thus be achieved.

The **hardware RESET# pin** terminates any operation in progress and resets the internal state machine to reading array data. The RESET# pin may be tied to the system reset circuitry. A system reset would thus also reset the device, enabling the system microprocessor to read the boot-up firmware from the Flash memory.

The device offers two power-saving features. When addresses are stable for a specified amount of time, the device enters the **automatic sleep mode**. The system can also place the device into the **standby mode**. Power consumption is greatly reduced in both these modes.

Spansion's Flash technology combines years of Flash memory manufacturing experience to produce the highest levels of quality, reliability and cost effectiveness. The device electrically erases all bits within a sector simultaneously via Fowler-Nordheim tunneling. The data is programmed using hot electron injection.

Table of Contents

Distinctive Characteristics	3
General Description	4
1. Product Selector Guide	9
2. Block Diagram	9
3. Connection Diagrams	10
3.1 Special Handling Instructions for FBGA Package	11
4. Pin Configuration	12
5. Logic Symbol	12
6. Ordering Information	13
6.1 Standard Products	13
7. Device Bus Operations	14
7.1 Word/Byte Configuration	14
7.2 Requirements for Reading Array Data	14
7.3 Writing Commands/Command Sequences	15
7.4 Program and Erase Operation Status	15
7.5 Standby Mode	15
7.6 Automatic Sleep Mode	15
7.7 RESET#: Hardware Reset Pin	16
7.8 Output Disable Mode	16
7.9 Autoselect Mode	18
7.10 Sector Protection/Unprotection	18
7.11 Temporary Sector Unprotect	19
7.12 Hardware Data Protection	21
8. Command Definitions	21
8.1 Reading Array Data	21
8.2 Reset Command	22
8.3 Autoselect Command Sequence	22
8.4 Word/Byte Program Command Sequence	22
8.5 Unlock Bypass Command Sequence	23
8.6 Chip Erase Command Sequence	24
8.7 Sector Erase Command Sequence	24
8.8 Erase Suspend/Erase Resume Commands	25
9. Write Operation Status	27
9.1 DQ7: Data# Polling	27
9.2 RY/BY#: Ready/Busy#	28
9.3 DQ6: Toggle Bit I	28
9.4 DQ2: Toggle Bit II	29
9.5 Reading Toggle Bits DQ6/DQ2	29
9.6 DQ5: Exceeded Timing Limits	30
9.7 DQ3: Sector Erase Timer	30
10. Absolute Maximum Ratings	31
11. Operating Ranges	32
12. DC Characteristics	33
12.1 Zero Power Flash	34
13. Test Conditions	35
14. Key to Switching Waveforms	35
15. AC Characteristics	36
15.1 Erase/Program Operations	39
15.2 Erase and Programming Performance	44
16. Physical Dimensions	46

16.1	TS 048—48-Pin Standard TSOP	46
16.2	VBK 048—48 Ball Fine-Pitch Ball Grid Array (FBGA) 8.15 x 6.15 mm	47
16.3	SO 044—44-Pin Small Outline Package	48
17.	Revision History	49
17.1	Revision A (September 8, 2004)	49
17.2	Revision A 1 (February 18, 2005)	49
17.3	Revision A2 (June 1, 2005)	49
17.4	Revision A3 (June 16, 2005)	50
17.5	Revision A4 (February 16, 2006)	50
17.6	Revision A5 (May 22, 2006)	50
17.7	Revision A6 (September 6, 2006)	50
17.8	Revision A7 (October 31, 2006)	50
17.9	Revision A8 (August 29, 2007)	50
17.10	Revision A9 (September 19, 2007)	50
17.11	Revision A10 (November 27, 2007)	51
17.12	Revision A11 (February 18, 2009)	51

Figures

Figure 3.1	Standard TSOP	10
Figure 3.2	SO Pinout.	10
Figure 3.3	Fine-pitch BGA Pinout (Top View, Balls Facing Down)	11
Figure 7.1	Temporary Sector Unprotect Operation.	19
Figure 7.2	In-System Sector Protect/Sector Unprotect Algorithms	20
Figure 8.1	Program Operation	23
Figure 8.2	Erase Operation.	25
Figure 9.1	Data# Polling Algorithm	28
Figure 9.2	Toggle Bit Algorithm.	30
Figure 11.1	Maximum Negative Overshoot Waveform	32
Figure 11.2	Maximum Positive Overshoot Waveform.	32
Figure 12.1	I _{CC1} Current vs. Time (Showing Active and Automatic Sleep Currents)	34
Figure 12.2	Typical I _{CC1} vs. Frequency	34
Figure 13.1	Test Setup	35
Figure 14.1	Input Waveforms and Measurement Levels	35
Figure 15.1	Read Operations Timings	36
Figure 15.2	RESET# Timings	37
Figure 15.3	BYTE# Timings for Read Operations.	38
Figure 15.4	BYTE# Timings for Write Operations.	38
Figure 15.5	Program Operation Timings.	39
Figure 15.6	Chip/Sector Erase Operation Timings	40
Figure 15.7	Back to Back Read/Write Cycle Timing	40
Figure 15.8	Data# Polling Timings (During Embedded Algorithms)	41
Figure 15.9	Toggle Bit Timings (During Embedded Algorithms).	41
Figure 15.10	DQ2 vs. DQ6	42
Figure 15.11	Temporary Sector Unprotect Timing Diagram	42
Figure 15.12	Sector Protect/Unprotect Timing Diagram	43
Figure 15.13	Alternate CE# Controlled Write Operation Timings	44

Tables

Table 7.1	S29AL008D Device Bus Operations	14
Table 7.2	S29AL008D Top Boot Block Sector Addresses	16
Table 7.3	S29AL008D Bottom Boot Block Sector Addresses	17
Table 7.4	S29AL008D Autoselect Codes (High Voltage Method)	18
Table 8.1	S29AL008D Command Definitions	26
Table 9.1	Write Operation Status	31
Table 13.1	Test Specifications	35
Table 15.1	Read Operations	36
Table 15.2	Hardware Reset (RESET#)	37
Table 15.3	Word/Byte Configuration (BYTE#)	38
Table 15.4	Temporary Sector Unprotect	42
Table 15.5	Alternate CE# Controlled Erase/Program Operations	43
Table 15.6	Latchup Characteristics	45
Table 15.7	TSOP, SO, and BGA Pin Capacitance	45

1. Product Selector Guide

Family Part Number		S29AL008D			
Speed Options	Full Voltage Range: $V_{CC} = 2.7 - 3.6\text{ V}$		60	70	90
	Regulated Voltage Range: $V_{CC} = 3.0 - 3.6\text{ V}$	55			
Max access time, ns (t_{ACC})		55	60	70	90
Max CE# access time, ns (t_{CE})		55	60	70	90
Max OE# access time, ns (t_{OE})		25	25	30	35

Note
See AC Characteristics on page 36 for full specifications.

2. Block Diagram

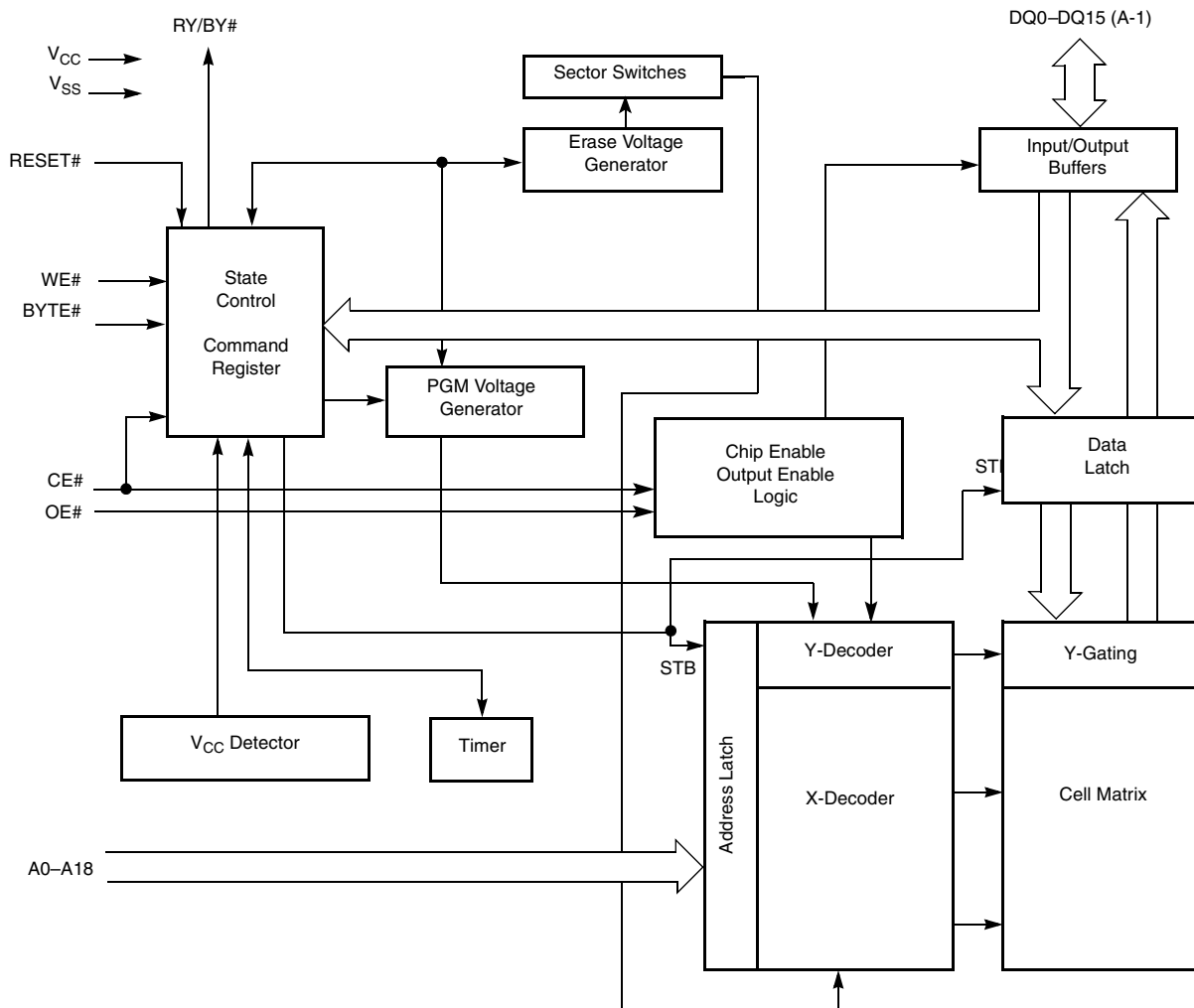

3. Connection Diagrams

Figure 3.1 Standard TSOP

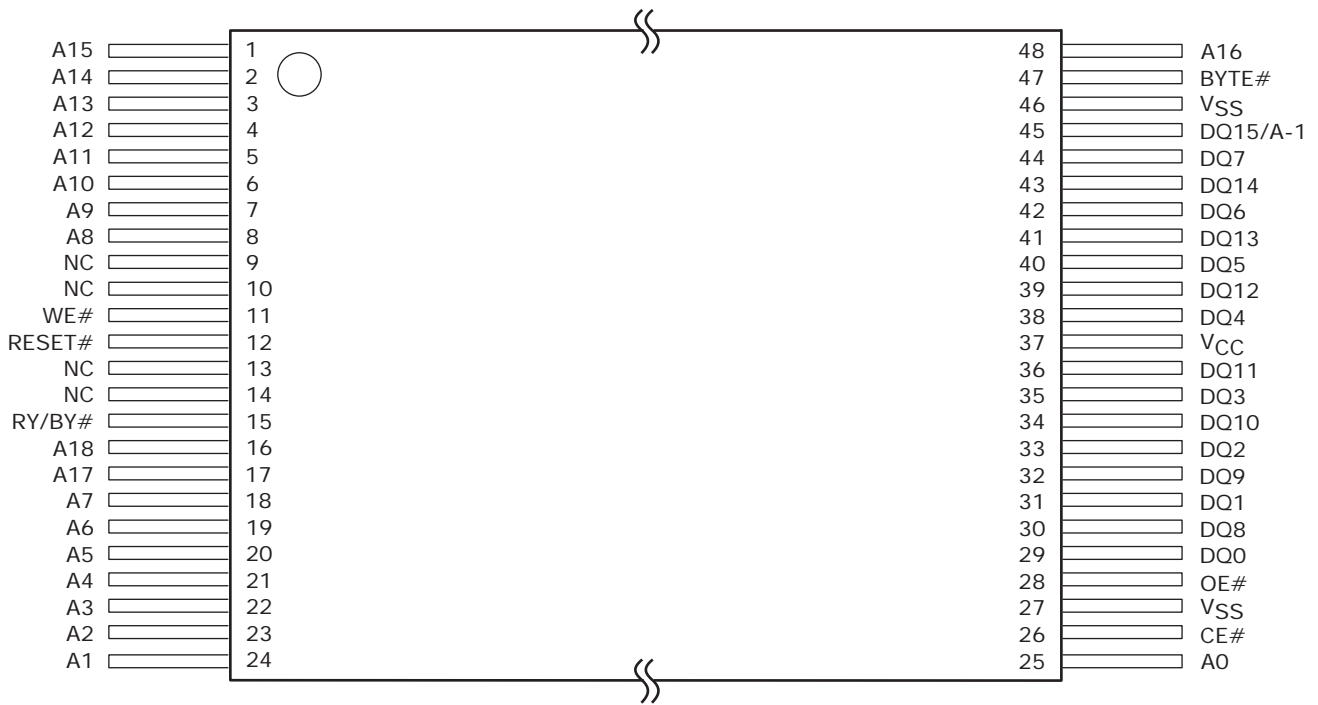

Figure 3.2 SO Pinout

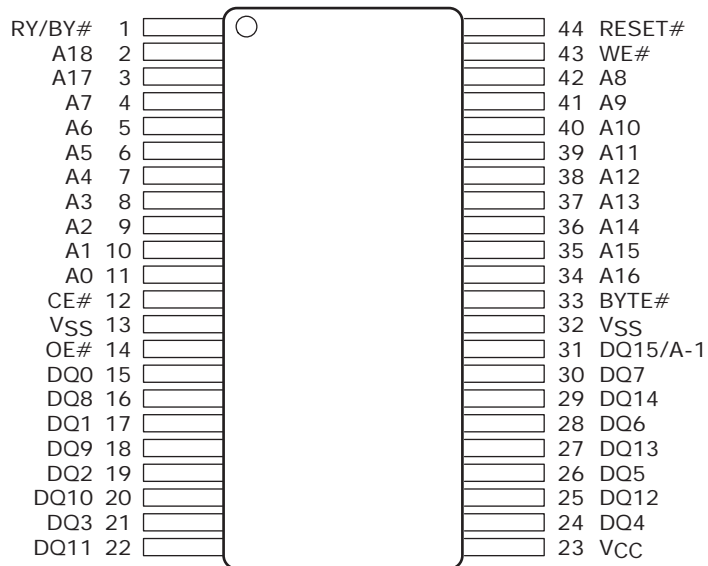
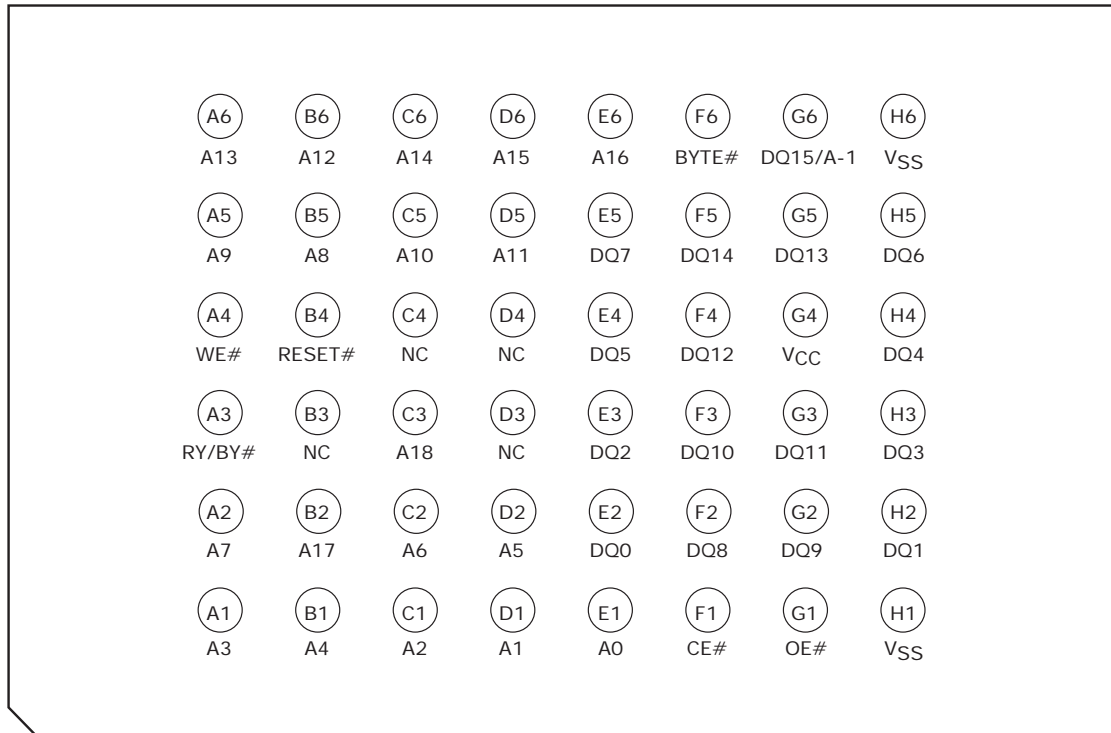

Figure 3.3 Fine-pitch BGA Pinout (Top View, Balls Facing Down)

3.1 Special Handling Instructions for FBGA Package

Special handling is required for Flash Memory products in FBGA packages. Flash memory devices in FBGA packages may be damaged if exposed to ultrasonic cleaning methods. The package and/or data integrity may be compromised if the package body is exposed to temperatures above 150°C for prolonged periods of time.

4. Pin Configuration

I/O Name	Description
A0–A18	19 addresses
DQ0–DQ14	15 data inputs/outputs
DQ15/A-1	DQ15 (data input/output, word mode), A-1 (LSB address input, byte mode)
BYTE#	Selects 8-bit or 16-bit mode
CE#	Chip enable
OE#	Output enable
WE#	Write enable
RESET#	Hardware reset pin, active low
RY/BY#	Ready/Busy# output
V _{CC}	3.0 volt-only single power supply (see Product Selector Guide on page 9 for speed options and voltage supply tolerances)
V _{SS}	Device ground
NC	Pin not connected internally

5. Logic Symbol

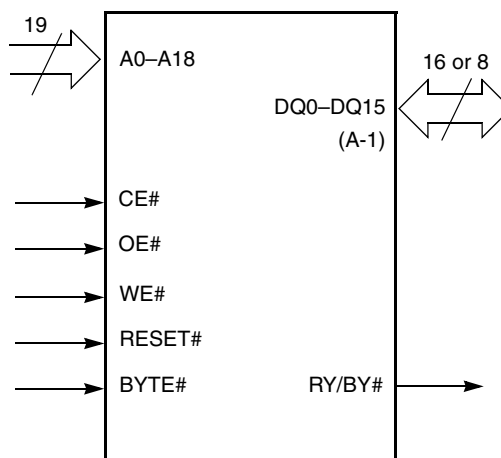

6. Ordering Information

This product has been retired and is not recommended for designs. For new and current designs, S29AL008J supercedes S29AL008D. This is the factory-recommended migration path. Please refer to the S29AL008J data sheet for specifications and ordering information.

6.1 Standard Products

Spansion standard products are available in several packages and operating ranges. The order number (Valid Combination) is formed by a combination of the elements below.

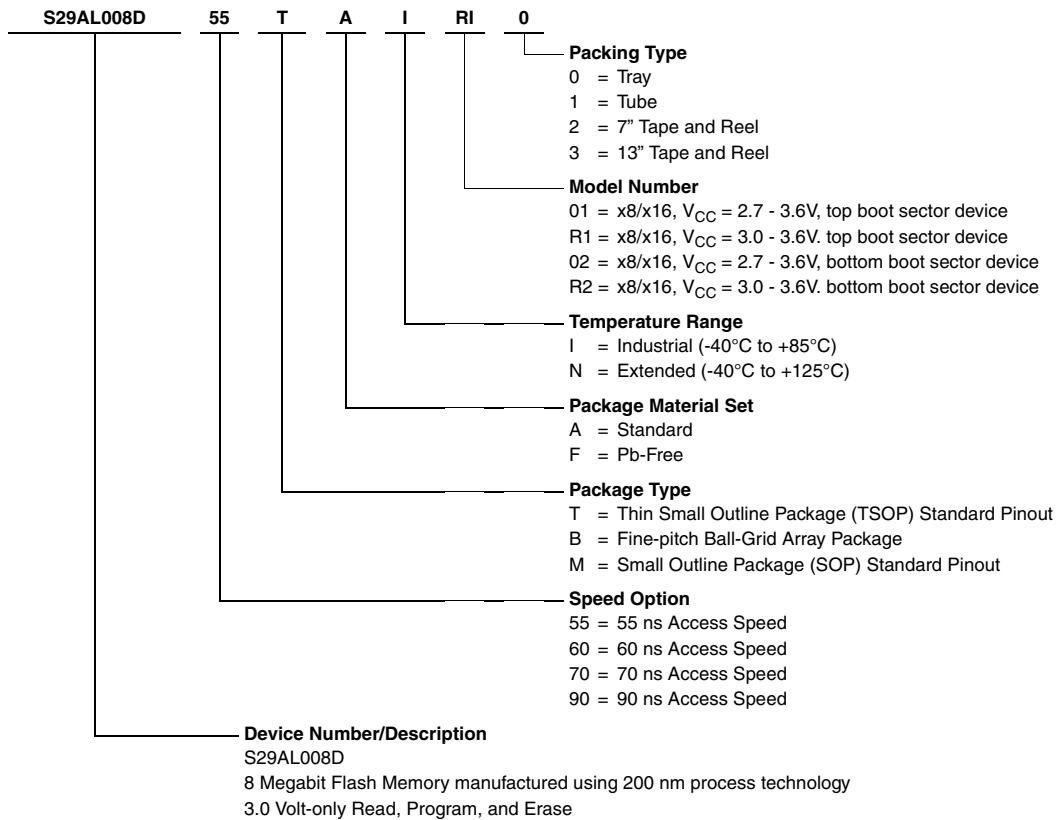

Valid Combinations

Valid Combinations list configurations planned to be supported in volume for this device. Consult your local sales office to confirm availability of specific valid combinations and to check on newly released combinations.

S29AL008D Valid Combinations						
Device Number	Speed Option	Package Type, Material, and Temperature Range	Model Number	Packing Type	Package Description	
S29AL008D	55	TAI, TFI	R1, R2	0, 3 (Note 1)	TS048 (Note 3)	TSOP
	60, 70, 90	TAI, TFI, TAN, TFN	01, 02			
	55	BAI, BFI	R1, R2	0, 2, 3 (Note 1)	VBK048 (Note 4)	Fine-Pitch BGA
	60, 70, 90	BAI, BFI, BAN, BFN	01, 02			
	55	MAI, MFI	R1, R2	0, 1, 3 (Note 2)	SO044 (Note 3)	SOP
	60, 70, 90	MAI, MFI, MAN, MFN	01, 02			

Notes

1. Type 0 is standard. Specify other options as required.
2. Type 1 is standard. Specify other options as required.
3. TSOP and SOP package markings omit packing type designator from ordering part number.
4. BGA package marking omits leading S29 and packing type designator from ordering part number.

7. Device Bus Operations

This section describes the requirements and use of the device bus operations, which are initiated through the internal command register. The command register itself does not occupy any addressable memory location. The register is composed of latches that store the commands, along with the address and data information needed to execute the command. The contents of the register serve as inputs to the internal state machine. The state machine outputs dictate the function of the device. [Table 7.1](#) lists the device bus operations, the inputs and control levels they require, and the resulting output. The following subsections describe each of these operations in further detail.

Table 7.1 S29AL008D Device Bus Operations

Operation	CE#	OE#	WE#	RESET#	Addresses (Note 1)	DQ0– DQ7	DQ8–DQ15	
							BYTE# = V _{IH}	BYTE# = V _{IL}
Read	L	L	H	H	A _{IN}	D _{OUT}	D _{OUT}	DQ8–DQ14 = High-Z, DQ15 = A-1
Write	L	H	L	H	A _{IN}	D _{IN}	D _{IN}	
Standby	V _{CC} ± 0.3 V	X	X	V _{CC} ± 0.3 V	X	High-Z	High-Z	High-Z
Output Disable	L	H	H	H	X	High-Z	High-Z	High-Z
Reset	X	X	X	L	X	High-Z	High-Z	High-Z
Sector Protect (Note 2)	L	H	L	V _{ID}	Sector Address, A6 = L, A1 = H, A0 = L	D _{IN}	X	X
Sector Unprotect (Note 2)	L	H	L	V _{ID}	Sector Address, A6 = H, A1 = H, A0 = L	D _{IN}	X	X
Temporary Sector Unprotect	X	X	X	V _{ID}	A _{IN}	D _{IN}	D _{IN}	High-Z

Legend

L = Logic Low = V_{IL}
H = Logic High = V_{IH}
V_{ID} = 12.0 ± 0.5 V
X = Don't Care
A_{IN} = Address In
D_{IN} = Data In
D_{OUT} = Data Out

Notes

- Addresses are A18:A0 in word mode (BYTE# = V_{IH}), A18:A-1 in byte mode (BYTE# = V_{IL}).
- The sector protect and sector unprotect functions may also be implemented via programming equipment. See [Sector Protection/Unprotection](#) on page 18.

7.1 Word/Byte Configuration

The BYTE# pin controls whether the device data I/O pins DQ15–DQ0 operate in the byte or word configuration. If the BYTE# pin is set at logic 1, the device is in word configuration, DQ15–DQ0 are active and controlled by CE# and OE#.

If the BYTE# pin is set at logic 0, the device is in byte configuration, and only data I/O pins DQ0–DQ7 are active and controlled by CE# and OE#. The data I/O pins DQ8–DQ14 are tri-stated, and the DQ15 pin is used as an input for the LSB (A-1) address function.

7.2 Requirements for Reading Array Data

To read array data from the outputs, the system must drive the CE# and OE# pins to V_{IL}. CE# is the power control and selects the device. OE# is the output control and gates array data to the output pins. WE# should remain at V_{IH}. The BYTE# pin determines whether the device outputs array data in words or bytes.

The internal state machine is set for reading array data upon device power-up, or after a hardware reset. This ensures that no spurious alteration of the memory content occurs during the power transition. No command is necessary in this mode to obtain array data. Standard microprocessor read cycles that assert valid addresses on the device address inputs produce valid data on the device data outputs. The device remains enabled for read access until the command register contents are altered.

See [Reading Array Data on page 21](#) for more information. Refer to [Table 15.1, Read Operations on page 36](#) for timing specifications and to [Figure 15.1 on page 36](#) for the timing diagram. I_{CC1} in [DC Characteristics on page 33](#) represents the active current specification for reading array data.

7.3 Writing Commands/Command Sequences

To write a command or command sequence (which includes programming data to the device and erasing sectors of memory), the system must drive WE# and CE# to V_{IL} , and OE# to V_{IH} .

For program operations, the BYTE# pin determines whether the device accepts program data in bytes or words. Refer to [Word/Byte Configuration on page 14](#) for more information.

The device features an **Unlock Bypass** mode to facilitate faster programming. Once the device enters the Unlock Bypass mode, only two write cycles are required to program a word or byte, instead of four. The [Word/Byte Program Command Sequence on page 22](#) contains details on programming data to the device using both standard and Unlock Bypass command sequences.

An erase operation can erase one sector, multiple sectors, or the entire device. [Table 7.2 on page 16](#) and [Table 7.3 on page 17](#) indicate the address space that each sector occupies. A *sector address* consists of the address bits required to uniquely select a sector. The [Command Definitions on page 21](#) contains details on erasing a sector or the entire chip, or suspending/resuming the erase operation.

After the system writes the autoselect command sequence, the device enters the autoselect mode. The system can then read autoselect codes from the internal register (which is separate from the memory array) on DQ7–DQ0. Standard read cycle timings apply in this mode. Refer to the [Autoselect Mode on page 18](#) and [Autoselect Command Sequence on page 22](#) for more information.

I_{CC2} in [DC Characteristics on page 33](#) represents the active current specification for the write mode. The [AC Characteristics on page 36](#) contains timing specification tables and timing diagrams for write operations.

7.4 Program and Erase Operation Status

During an erase or program operation, the system may check the status of the operation by reading the status bits on DQ7–DQ0. Standard read cycle timings and I_{CC} read specifications apply. Refer to [Write Operation Status on page 27](#) for more information, and to [AC Characteristics on page 36](#) for timing diagrams.

7.5 Standby Mode

When the system is not reading or writing to the device, it can place the device in the standby mode. In this mode, current consumption is greatly reduced, and the outputs are placed in the high impedance state, independent of the OE# input.

The device enters the CMOS standby mode when the CE# and RESET# pins are both held at $V_{CC} \pm 0.3$ V. (Note that this is a more restricted voltage range than V_{IH} .) If CE# and RESET# are held at V_{IH} , but not within $V_{CC} \pm 0.3$ V, the device is in the standby mode, but the standby current is greater. The device requires standard access time (t_{CE}) for read access when the device is in either of these standby modes, before it is ready to read data.

If the device is deselected during erasure or programming, the device draws active current until the operation is completed.

In [DC Characteristics on page 33](#), I_{CC3} and I_{CC4} represents the standby current specification.

7.6 Automatic Sleep Mode

The automatic sleep mode minimizes Flash device energy consumption. The device automatically enables this mode when addresses remain stable for $t_{ACC} + 30$ ns. The automatic sleep mode is independent of the CE#, WE#, and OE# control signals. Standard address access timings provide new data when addresses are changed. While in sleep mode, output data is latched and always available to the system. I_{CC5} in [DC Characteristics on page 33](#) represents the automatic sleep mode current specification.

7.7 RESET#: Hardware Reset Pin

The RESET# pin provides a hardware method of resetting the device to reading array data. When the RESET# pin is driven low for at least a period of t_{RP} , the device **immediately terminates** any operation in progress, tristates all output pins, and ignores all read/write commands for the duration of the RESET# pulse. The device also resets the internal state machine to reading array data. The operation that was interrupted should be reinitiated once the device is ready to accept another command sequence, to ensure data integrity.

Current is reduced for the duration of the RESET# pulse. When RESET# is held at $V_{SS} \pm 0.3$ V, the device draws CMOS standby current (I_{CC4}). If RESET# is held at V_{IL} but not within $V_{SS} \pm 0.3$ V, the standby current is greater.

The RESET# pin may be tied to the system reset circuitry. A system reset would thus also reset the Flash memory, enabling the system to read the boot-up firmware from the Flash memory.

If RESET# is asserted during a program or erase operation, the RY/BY# pin remains a 0 (busy) until the internal reset operation is complete, which requires a time of t_{READY} (during Embedded Algorithms). The system can thus monitor RY/BY# to determine whether the reset operation is complete. If RESET# is asserted when a program or erase operation is not executing (RY/BY# pin is 1), the reset operation is completed within a time of t_{READY} (not during Embedded Algorithms). The system can read data t_{RH} after the RESET# pin returns to V_{IH} .

Refer to [AC Characteristics on page 36](#) for RESET# parameters and to [Figure 15.2 on page 37](#) for the timing diagram.

7.8 Output Disable Mode

When the OE# input is at V_{IH} , output from the device is disabled. The output pins are placed in the high impedance state.

Table 7.2 S29AL008D Top Boot Block Sector Addresses

Sector	A18	A17	A16	A15	A14	A13	A12	Sector Size (Kbytes/ Kwords)	Address Range (in hexadecimal)	
									(x8) Address Range	(x16) Address Range
SA0	0	0	0	0	X	X	X	64/32	0000h–0FFFFh	0000h–07FFFh
SA1	0	0	0	1	X	X	X	64/32	1000h–1FFFFh	0800h–0FFFFh
SA2	0	0	1	0	X	X	X	64/32	2000h–2FFFFh	1000h–17FFFh
SA3	0	0	1	1	X	X	X	64/32	3000h–3FFFFh	1800h–1FFFFh
SA4	0	1	0	0	X	X	X	64/32	4000h–4FFFFh	2000h–27FFFh
SA5	0	1	0	1	X	X	X	64/32	5000h–5FFFFh	2800h–2FFFFh
SA6	0	1	1	0	X	X	X	64/32	6000h–6FFFFh	3000h–37FFFh
SA7	0	1	1	1	X	X	X	64/32	7000h–7FFFFh	3800h–3FFFFh
SA8	1	0	0	0	X	X	X	64/32	8000h–8FFFFh	4000h–47FFFh
SA9	1	0	0	1	X	X	X	64/32	9000h–9FFFFh	4800h–4FFFFh
SA10	1	0	1	0	X	X	X	64/32	A000h–AFFFFh	5000h–57FFFh
SA11	1	0	1	1	X	X	X	64/32	B000h–BFFFFh	5800h–5FFFFh
SA12	1	1	0	0	X	X	X	64/32	C000h–CFFFFh	6000h–67FFFh
SA13	1	1	0	1	X	X	X	64/32	D000h–DFFFFh	6800h–6FFFFh
SA14	1	1	1	0	X	X	X	64/32	E000h–EFFFFh	7000h–77FFFh
SA15	1	1	1	1	0	X	X	32/16	F000h–F7FFFh	7800h–7BFFFh
SA16	1	1	1	1	1	0	0	8/4	F800h–F9FFFh	7C00h–7CFFFh
SA17	1	1	1	1	1	0	1	8/4	FA00h–FBFFFh	7D00h–7DFFFh
SA18	1	1	1	1	1	1	X	16/8	FC00h–FFFFh	7E00h–7FFFFh

Note

Address range is A18:A-1 in byte mode and A18:A0 in word mode. See [Word/Byte Configuration on page 14](#).

Table 7.3 S29AL008D Bottom Boot Block Sector Addresses

Sector	A18	A17	A16	A15	A14	A13	A12	Sector Size (Kbytes/ Kwords)	Address Range (in hexadecimal)	
									(x8) Address Range	(x16) Address Range
SA0	0	0	0	0	0	0	X	16/8	0000h–03FFFh	0000h–01FFFh
SA1	0	0	0	0	0	1	0	8/4	0400h–05FFFh	0200h–02FFFh
SA2	0	0	0	0	0	1	1	8/4	0600h–07FFFh	0300h–03FFFh
SA3	0	0	0	0	1	X	X	32/16	0800h–0FFFFh	0400h–07FFFh
SA4	0	0	0	1	X	X	X	64/32	1000h–1FFFFh	0800h–0FFFFh
SA5	0	0	1	0	X	X	X	64/32	2000h–2FFFFh	1000h–17FFFh
SA6	0	0	1	1	X	X	X	64/32	3000h–3FFFFh	1800h–1FFFFh
SA7	0	1	0	0	X	X	X	64/32	4000h–4FFFFh	2000h–27FFFh
SA8	0	1	0	1	X	X	X	64/32	5000h–5FFFFh	2800h–2FFFFh
SA9	0	1	1	0	X	X	X	64/32	6000h–6FFFFh	3000h–37FFFh
SA10	0	1	1	1	X	X	X	64/32	7000h–7FFFFh	3800h–3FFFFh
SA11	1	0	0	0	X	X	X	64/32	8000h–8FFFFh	4000h–47FFFh
SA12	1	0	0	1	X	X	X	64/32	9000h–9FFFFh	4800h–4FFFFh
SA13	1	0	1	0	X	X	X	64/32	A000h–AFFFFh	5000h–57FFFh
SA14	1	0	1	1	X	X	X	64/32	B000h–BFFFFh	5800h–5FFFFh
SA15	1	1	0	0	X	X	X	64/32	C000h–CFFFFh	6000h–67FFFh
SA16	1	1	0	1	X	X	X	64/32	D000h–DFFFFh	6800h–6FFFFh
SA17	1	1	1	0	X	X	X	64/32	E000h–EFFFFh	7000h–77FFFh
SA18	1	1	1	1	X	X	X	64/32	F000h–FFFFh	7800h–7FFFFh

Note

Address range is A18:A-1 in byte mode and A18:A0 in word mode. See [Word/Byte Configuration on page 14](#).

7.9 Autoselect Mode

The autoselect mode provides manufacturer and device identification, and sector protection verification, through identifier codes output on DQ7–DQ0. This mode is primarily intended for programming equipment to automatically match a device to be programmed with its corresponding programming algorithm. However, the autoselect codes can also be accessed in-system through the command register.

When using programming equipment, the autoselect mode requires V_{ID} (11.5 V to 12.5 V) on address pin A9. Address pins A6, A1, and A0 must be as shown in [Table 7.4](#). In addition, when verifying sector protection, the sector address must appear on the appropriate highest order address bits (see [Table 7.2 on page 16](#) and [Table 7.3 on page 17](#)). [Table 7.4](#) shows the remaining address bits that are don't care. When all necessary bits are set as required, the programming equipment may then read the corresponding identifier code on DQ7–DQ0.

To access the autoselect codes in-system, the host system can issue the autoselect command via the command register, as shown in [Table 8.1 on page 26](#). This method does not require V_{ID} . See [Command Definitions on page 21](#) for details on using the autoselect mode.

Table 7.4 S29AL008D Autoselect Codes (High Voltage Method)

Description	Mode	CE#	OE#	WE#	A18 to A12	A11 to A10	A9	A8 to A7	A6	A5 to A4	A3 to A2	A1	A0	DQ8 to DQ15	DQ7 to DQ0
Manufacturer ID: Spansion		L	L	H	X	X	V_{ID}	X	L	X	L	L	L	X	01h
Device ID: S29AL008D (Top Boot Block)	Word	L	L	H	X	X	V_{ID}	X	L	X	L	L	H	22h	DAh
	Byte	L	L	H										X	DAh
Device ID: S29AL008D (Bottom Boot Block)	Word	L	L	H	X	X	V_{ID}	X	L	X	L	L	H	22h	5Bh
	Byte	L	L	H										X	5Bh
Sector Protection Verification		L	L	H	SA	X	V_{ID}	X	L	X	L	H	L	X	01h (protected)
														X	00h (unprotected)

Legend

L = Logic Low = V_{IL}
H = Logic High = V_{IH}
SA = Sector Address
X = Don't care.

7.10 Sector Protection/Unprotection

The hardware sector protection feature disables both program and erase operations in any sector. The hardware sector unprotection feature re-enables both program and erase operations in previously protected sectors.

The device is shipped with all sectors unprotected. Spansion offers the option of programming and protecting sectors at its factory prior to shipping the device through Spansion's ExpressFlash™ Service. Contact an Spansion representative for details.

It is possible to determine whether a sector is protected or unprotected. See [Autoselect Mode on page 18](#) for details.

Sector Protection/unprotection can be implemented via two methods.

The primary method requires V_{ID} on the RESET# pin only, and can be implemented either in-system or via programming equipment. [Figure 7.2 on page 20](#) shows the algorithms and [Figure 15.12 on page 43](#) shows the timing diagram. This method uses standard microprocessor bus cycle timing. For sector unprotect, all unprotected sectors must first be protected prior to the first sector unprotect write cycle.

The alternate method intended only for programming equipment requires V_{ID} on address pin A9 and OE#. This method is compatible with programmer routines written for earlier 3.0 volt-only Spansion flash devices. Publication number 20536 contains further details; contact an Spansion representative to request a copy.

7.11 Temporary Sector Unprotect

This feature allows temporary unprotection of previously protected sectors to change data in-system. The Sector Unprotect mode is activated by setting the RESET# pin to V_{ID} . During this mode, formerly protected sectors can be programmed or erased by selecting the sector addresses. Once V_{ID} is removed from the RESET# pin, all the previously protected sectors are protected again.

Figure 7.1 shows the algorithm, and Figure 15.11 on page 42 shows the timing diagrams, for this feature.

Figure 7.1 Temporary Sector Unprotect Operation

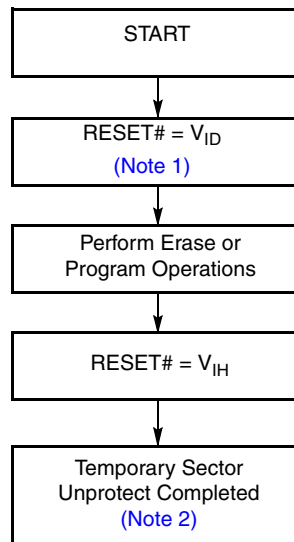

Notes

1. All protected sectors unprotected.
2. All previously protected sectors are protected once again.

Figure 7.2 In-System Sector Protect/Sector Unprotect Algorithms

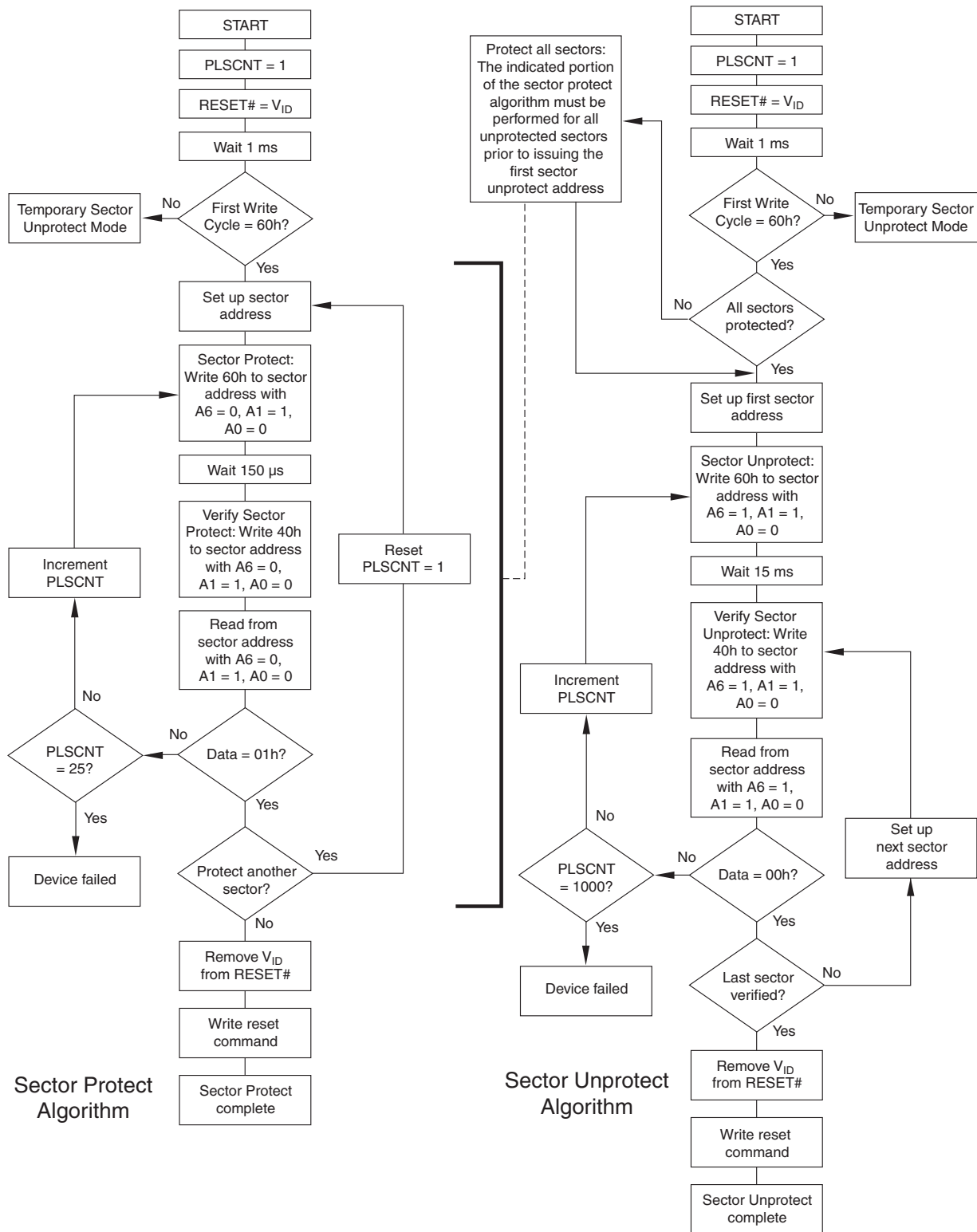

7.12 Hardware Data Protection

The command sequence requirement of unlock cycles for programming or erasing provides data protection against inadvertent writes (refer to [Table 8.1 on page 26](#) for command definitions). In addition, the following hardware data protection measures prevent accidental erasure or programming, which might otherwise be caused by spurious system level signals during V_{CC} power-up and power-down transitions, or from system noise.

7.12.1 Low V_{CC} Write Inhibit

When V_{CC} is less than V_{LKO} , the device does not accept any write cycles. This protects data during V_{CC} power-up and power-down. The command register and all internal program/erase circuits are disabled, and the device resets. Subsequent writes are ignored until V_{CC} is greater than V_{LKO} . The system must provide the proper signals to the control pins to prevent unintentional writes when V_{CC} is greater than V_{LKO} .

7.12.2 Write Pulse *Glitch* Protection

Noise pulses of less than 5 ns (typical) on OE#, CE# or WE# do not initiate a write cycle.

7.12.3 Logical Inhibit

Write cycles are inhibited by holding any one of OE# = V_{IL} , CE# = V_{IH} or WE# = V_{IH} . To initiate a write cycle, CE# and WE# must be a logical zero while OE# is a logical one.

7.12.4 Power-Up Write Inhibit

If WE# = CE# = V_{IL} and OE# = V_{IH} during power up, the device does not accept commands on the rising edge of WE#. The internal state machine is automatically reset to reading array data on power-up.

8. Command Definitions

Writing specific address and data commands or sequences into the command register initiates device operations. [Table 8.1 on page 26](#) defines the valid register command sequences. Writing **incorrect address and data values** or writing them in the **improper sequence** resets the device to reading array data.

All addresses are latched on the falling edge of WE# or CE#, whichever happens later. All data is latched on the rising edge of WE# or CE#, whichever happens first. Refer to the appropriate timing diagrams in the [AC Characteristics on page 36](#).

8.1 Reading Array Data

The device is automatically set to reading array data after device power-up. No commands are required to retrieve data. The device is also ready to read array data after completing an Embedded Program or Embedded Erase algorithm.

After the device accepts an Erase Suspend command, the device enters the Erase Suspend mode. The system can read array data using the standard read timings, except that if it reads at an address within erase-suspended sectors, the device outputs status data. After completing a programming operation in the Erase Suspend mode, the system may once again read array data with the same exception. See [Erase Suspend/ Erase Resume Commands on page 25](#) for more information on this mode.

The system *must* issue the reset command to re-enable the device for reading array data if DQ5 goes high, or while in the autoselect mode. See [Reset Command on page 22](#).

See also [Requirements for Reading Array Data on page 14](#) for more information. [Table 15.1, Read Operations on page 36](#) provides the read parameters, and [Figure 15.1 on page 36](#) shows the timing diagram.

8.2 Reset Command

Writing the reset command to the device resets the device to reading array data. Address bits are don't care for this command.

The reset command may be written between the sequence cycles in an erase command sequence before erasing begins. This resets the device to reading array data. Once erasure begins, however, the device ignores reset commands until the operation is complete.

The reset command may be written between the sequence cycles in a program command sequence before programming begins. This resets the device to reading array data (also applies to programming in Erase Suspend mode). Once programming begins, however, the device ignores reset commands until the operation is complete.

The reset command may be written between the sequence cycles in an autoselect command sequence. Once in the autoselect mode, the reset command *must* be written to return to reading array data (also applies to autoselect during Erase Suspend).

If DQ5 goes high during a program or erase operation, writing the reset command returns the device to reading array data (also applies during Erase Suspend).

8.3 Autoselect Command Sequence

The autoselect command sequence allows the host system to access the manufacturer and device codes, and determine whether or not a sector is protected. [Table 8.1 on page 26](#) shows the address and data requirements. This method is an alternative to that shown in [Table 7.4 on page 18](#), which is intended for PROM programmers and requires V_{ID} on address bit A9.

The autoselect command sequence is initiated by writing two unlock cycles, followed by the autoselect command. The device then enters the autoselect mode, and the system may read at any address any number of times, without initiating another command sequence.

A read cycle at address XX00h retrieves the manufacturer code. A read cycle at address XX01h in word mode (or 02h in byte mode) returns the device code. A read cycle containing a sector address (SA) and the address 02h in word mode (or 04h in byte mode) returns 01h if that sector is protected, or 00h if it is unprotected. Refer to [Table 7.2 on page 16](#) and [Table 7.3 on page 17](#) for valid sector addresses.

The system must write the reset command to exit the autoselect mode and return to reading array data.

8.4 Word/Byte Program Command Sequence

The system may program the device by word or byte, depending on the state of the BYTE# pin. Programming is a four-bus-cycle operation. The program command sequence is initiated by writing two unlock write cycles, followed by the program set-up command. The program address and data are written next, which in turn initiate the Embedded Program algorithm. The system is *not* required to provide further controls or timings. The device automatically provides internally generated program pulses and verifies the programmed cell margin. [Table 8.1 on page 26](#) shows the address and data requirements for the byte program command sequence.

When the Embedded Program algorithm is complete, the device then returns to reading array data and addresses are no longer latched. The system can determine the status of the program operation by using DQ7, DQ6, or RY/BY#. See [Write Operation Status on page 27](#) for information on these status bits.

Any commands written to the device during the Embedded Program Algorithm are ignored. Note that a **hardware reset** immediately terminates the programming operation. The program command sequence should be reinitiated once the device resets to reading array data, to ensure data integrity.

Programming is allowed in any sequence and across sector boundaries. **A bit cannot be programmed from a 0 back to a 1.** Attempting to do so may halt the operation and set DQ5 to 1, or cause the Data# Polling algorithm to indicate the operation was successful. However, a succeeding read shows that the data is still 0. Only erase operations can convert a 0 to a 1.

8.5 Unlock Bypass Command Sequence

The unlock bypass feature allows the system to program bytes or words to the device faster than using the standard program command sequence. The unlock bypass command sequence is initiated by first writing two unlock cycles. This is followed by a third write cycle containing the unlock bypass command, 20h. The device then enters the unlock bypass mode. A two-cycle unlock bypass program command sequence is all that is required to program in this mode. The first cycle in this sequence contains the unlock bypass program command, A0h; the second cycle contains the program address and data. Additional data is programmed in the same manner. This mode dispenses with the initial two unlock cycles required in the standard program command sequence, resulting in faster total programming time. [Table 8.1](#) shows the requirements for the command sequence.

During the unlock bypass mode, only the Unlock Bypass Program and Unlock Bypass Reset commands are valid. To exit the unlock bypass mode, the system must issue the two-cycle unlock bypass reset command sequence. The first cycle must contain the data 90h; the second cycle the data 00h. Addresses are don't care for both cycles. The device then returns to reading array data.

[Table 8.1](#) illustrates the algorithm for the program operation. See [Erase/Program Operations on page 39](#) for parameters, and [Figure 15.5 on page 39](#) for timing diagrams.

Figure 8.1 Program Operation

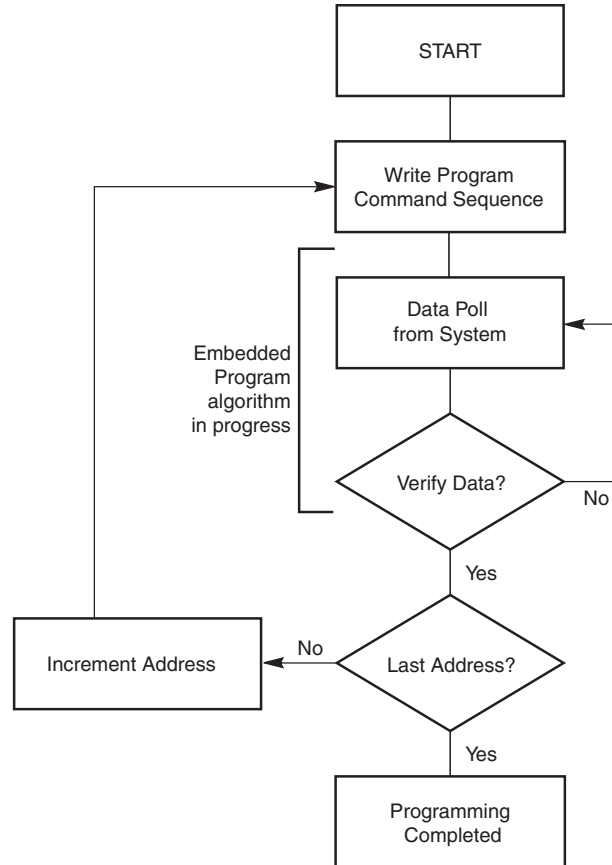

Note

See [Table 8.1 on page 26](#) for program command sequence.

8.6 Chip Erase Command Sequence

Chip erase is a six bus cycle operation. The chip erase command sequence is initiated by writing two unlock cycles, followed by a set-up command. Two additional unlock write cycles are then followed by the chip erase command, which in turn invokes the Embedded Erase algorithm. The device does *not* require the system to preprogram prior to erase. The Embedded Erase algorithm automatically preprograms and verifies the entire memory for an all zero data pattern prior to electrical erase. The system is not required to provide any controls or timings during these operations. [Table 8.1 on page 26](#) shows the address and data requirements for the chip erase command sequence.

Any commands written to the chip during the Embedded Erase algorithm are ignored. Note that a **hardware reset** during the chip erase operation immediately terminates the operation. The Chip Erase command sequence should be reinitiated once the device returns to reading array data, to ensure data integrity.

The system can determine the status of the erase operation by using DQ7, DQ6, DQ2, or RY/BY#. See [Write Operation Status on page 27](#) for information on these status bits. When the Embedded Erase algorithm is complete, the device returns to reading array data and addresses are no longer latched.

[Figure 8.2 on page 25](#) illustrates the algorithm for the erase operation. See [Erase/Program Operations on page 39](#) for parameters, and [Figure 15.6 on page 40](#) for timing diagrams.

8.7 Sector Erase Command Sequence

Sector erase is a six bus cycle operation. The sector erase command sequence is initiated by writing two unlock cycles, followed by a set-up command. Two additional unlock write cycles are then followed by the address of the sector to be erased, and the sector erase command. [Table 8.1 on page 26](#) shows the address and data requirements for the sector erase command sequence.

The device does *not* require the system to preprogram the memory prior to erase. The Embedded Erase algorithm automatically programs and verifies the sector for an all zero data pattern prior to electrical erase. The system is not required to provide any controls or timings during these operations.

After the command sequence is written, a sector erase time-out of 50 μ s begins. During the time-out period, additional sector addresses and sector erase commands may be written. Loading the sector erase buffer may be done in any sequence, and the number of sectors may be from one sector to all sectors. The time between these additional cycles must be less than 50 μ s, otherwise the last address and command might not be accepted, and erasure may begin. It is recommended that processor interrupts be disabled during this time to ensure all commands are accepted. The interrupts can be re-enabled after the last Sector Erase command is written. If the time between additional sector erase commands can be assumed to be less than 50 μ s, the system need not monitor DQ3. **Any command other than Sector Erase or Erase Suspend during the time-out period resets the device to reading array data.** The system must rewrite the command sequence and any additional sector addresses and commands.

The system can monitor DQ3 to determine if the sector erase timer has timed out. (See [DQ3: Sector Erase Timer on page 30](#).) The time-out begins from the rising edge of the final WE# pulse in the command sequence.

Once the sector erase operation begins, only the Erase Suspend command is valid. All other commands are ignored. Note that a **hardware reset** during the sector erase operation immediately terminates the operation. The Sector Erase command sequence should be reinitiated once the device returns to reading array data, to ensure data integrity.

When the Embedded Erase algorithm is complete, the device returns to reading array data and addresses are no longer latched. The system can determine the status of the erase operation by using DQ7, DQ6, DQ2, or RY/BY#. Refer to [Write Operation Status on page 27](#) for information on these status bits.

[Figure 8.2 on page 25](#) illustrates the algorithm for the erase operation. Refer to [Erase/Program Operations on page 39](#) for parameters, and to [Figure 15.6 on page 40](#) for timing diagrams.

8.8 Erase Suspend/Erase Resume Commands

The Erase Suspend command allows the system to interrupt a sector erase operation and then read data from, or program data to, any sector not selected for erasure. This command is valid only during the sector erase operation, including the 50 μ s time-out period during the sector erase command sequence. The Erase Suspend command is ignored if written during the chip erase operation or Embedded Program algorithm. Writing the Erase Suspend command during the Sector Erase time-out immediately terminates the time-out period and suspends the erase operation. Addresses are *don't-cares* when writing the Erase Suspend command.

When the Erase Suspend command is written during a sector erase operation, the device requires a maximum of 20 μ s to suspend the erase operation. However, when the Erase Suspend command is written during the sector erase time-out, the device immediately terminates the time-out period and suspends the erase operation.

After the erase operation is suspended, the system can read array data from or program data to any sector not selected for erasure. (The device *erase suspends* all sectors selected for erasure.) Normal read and write timings and command definitions apply. Reading at any address within erase-suspended sectors produces status data on DQ7–DQ0. The system can use DQ7, or DQ6 and DQ2 together, to determine if a sector is actively erasing or is erase-suspended. See [Write Operation Status on page 27](#) for information on these status bits.

After an erase-suspended program operation is complete, the system can once again read array data within non-suspended sectors. The system can determine the status of the program operation using the DQ7 or DQ6 status bits, just as in the standard program operation. See [Write Operation Status on page 27](#) for more information.

The system may also write the autoselect command sequence when the device is in the Erase Suspend mode. The device allows reading autoselect codes even at addresses within erasing sectors, since the codes are not stored in the memory array. When the device exits the autoselect mode, the device reverts to the Erase Suspend mode, and is ready for another valid operation. See [Autoselect Command Sequence on page 22](#) for more information.

The system must write the Erase Resume command (address bits are *don't care*) to exit the erase suspend mode and continue the sector erase operation. Further writes of the Resume command are ignored. Another Erase Suspend command can be written after the device resumes erasing.

Figure 8.2 Erase Operation

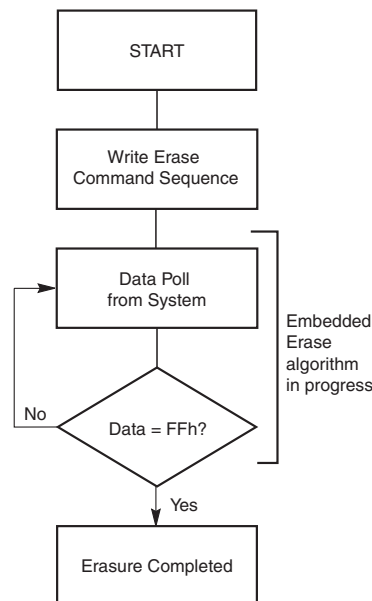

Notes

1. See [Table 8.1 on page 26](#) for erase command sequence.
2. See [DQ3: Sector Erase Timer on page 30](#) for more information.

Table 8.1 S29AL008D Command Definitions

Command Sequence (Note 1)			Cycles	Bus Cycles (Notes 2-5)											
				First		Second		Third		Fourth		Fifth		Sixth	
				Addr	Data	Addr	Data	Addr	Data	Addr	Data	Addr	Data	Addr	Data
Read (Note 6)			1	RA	RD										
Reset (Note 7)			1	XXX	F0										
Autoselect (Note 8)	Manufacturer ID	Word	4	555	AA	2AA	55	555	90	X00	01				
		Byte		AAA		555		AAA							
	Device ID, Top Boot Block	Word	4	555	AA	2AA	55	555	90	X01	22DA				
		Byte		AAA		555		AAA		X02	DA				
	Device ID, Bottom Boot Block	Word	4	555	AA	2AA	55	555	90	X01	225B				
		Byte		AAA		555		AAA		X02	5B				
	Sector Protect Verify (Note 9)	Word	4	555	AA	2AA	55	555	90	(SA) X02	XX00				
		Byte		AAA		555		AAA		(SA) X04	00				
										01					
Program	Word	4	555	AA	2AA	55	555	A0	PA	PD					
	Byte		AAA		555		AAA								
Unlock Bypass	Word	3	555	AA	2AA	55	555	20							
	Byte		AAA		555		AAA								
Unlock Bypass Program (Note 10)			2	XXX	A0	PA	PD								
Unlock Bypass Reset (Note 11)			2	XXX	90	XXX	00 (F0)								
Chip Erase	Word	6	555	AA	2AA	55	555	80	555	AA	2AA	55	555	10	
	Byte		AAA		555		AAA		AAA		555		AAA		
Sector Erase	Word	6	555	AA	2AA	55	555	80	555	AA	2AA	55	SA	30	
	Byte		AAA		555		AAA		AAA		555				
Erase Suspend (Note 12)			1	XXX	B0										
Erase Resume (Note 13)			1	XXX	30										

Legend

X = Don't care

RA = Address of the memory location to be read

RD = Data read from location RA during read operation, and

PA = Address of the memory location to be programmed. Addresses latch on the falling edge of the WE# or CE# pulse, whichever happens later.

PD = Data to be programmed at location PA. Data latches on the rising edge of WE# or CE# pulse, whichever happens first.

SA = Address of the sector to be verified (in autoselect mode) or erased. Address bits A18–A12 uniquely select any sector.

Notes

- See Table 7.1 on page 14 for a description of bus operations.
- All values are in hexadecimal.
- Except when reading array or autoselect data, all bus cycles are write operations.
- Data bits DQ15–DQ8 are don't cares for unlock and command cycles.
- Address bits A18–A11 are don't cares for unlock and command cycles, unless PA or SA required.
- No unlock or command cycles required when reading array data.
- The Reset command is required to return to reading array data when device is in the autoselect mode, or if DQ5 goes high (while the device is providing status data).
- The fourth cycle of the autoselect command sequence is a read cycle.
- The data is 00h for an unprotected sector and 01h for a protected sector. See Autoselect Command Sequence on page 22 for more information.
- The Unlock Bypass command is required prior to the Unlock Bypass Program command.
- The Unlock Bypass Reset command is required to return to reading array data when the device is in the unlock bypass mode.
- The system may read and program in non-erasing sectors, or enter the autoselect mode, when in the Erase Suspend mode. The Erase Suspend command is valid only during a sector erase operation.
- The Erase Resume command is valid only during the Erase Suspend mode.

9. Write Operation Status

The device provides several bits to determine the status of a write operation: DQ2, DQ3, DQ5, DQ6, DQ7, and RY/BY#. [Table 9.1 on page 31](#) and the following subsections describe the functions of these bits. DQ7, RY/BY#, and DQ6 each offer a method for determining whether a program or erase operation is complete or in progress. These three bits are discussed first.

9.1 DQ7: Data# Polling

The Data# Polling bit, DQ7, indicates to the host system whether an Embedded Algorithm is in progress or completed, or whether the device is in Erase Suspend. Data# Polling is valid after the rising edge of the final WE# pulse in the program or erase command sequence.

During the Embedded Program algorithm, the device outputs on DQ7 the complement of the datum programmed to DQ7. This DQ7 status also applies to programming during Erase Suspend. When the Embedded Program algorithm is complete, the device outputs the datum programmed to DQ7. The system must provide the program address to read valid status information on DQ7. If a program address falls within a protected sector, Data# Polling on DQ7 is active for approximately 1 μ s, then the device returns to reading array data.

During the Embedded Erase algorithm, Data# Polling produces a 0 on DQ7. When the Embedded Erase algorithm is complete, or if the device enters the Erase Suspend mode, Data# Polling produces a 1 on DQ7. This is analogous to the complement/true datum output described for the Embedded Program algorithm: the erase function changes all the bits in a sector to 1; prior to this, the device outputs the *complement*, or 0. The system must provide an address within any of the sectors selected for erasure to read valid status information on DQ7.

After an erase command sequence is written, if all sectors selected for erasing are protected, Data# Polling on DQ7 is active for approximately 100 μ s, then the device returns to reading array data. If not all selected sectors are protected, the Embedded Erase algorithm erases the unprotected sectors, and ignores the selected sectors that are protected.

When the system detects DQ7 changes from the complement to true data, it can read valid data at DQ7–DQ0 on the *following* read cycles. This is because DQ7 may change asynchronously with DQ0–DQ6 while Output Enable (OE#) is asserted low. [Figure 15.8, Data# Polling Timings \(During Embedded Algorithms\) on page 41](#), illustrates this.

[Table 9.1 on page 31](#) shows the outputs for Data# Polling on DQ7. [Figure 9.1 on page 28](#) shows the Data# Polling algorithm.

Figure 9.1 Data# Polling Algorithm

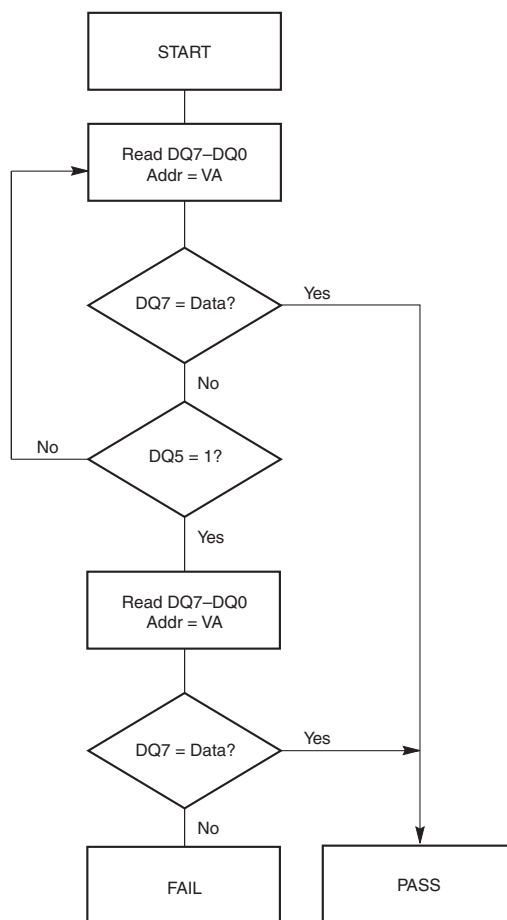

Notes

1. VA = Valid address for programming. During a sector erase operation, a valid address is an address within any sector selected for erasure. During chip erase, a valid address is any non-protected sector address.
2. DQ7 should be rechecked even if DQ5 = 1 because DQ7 may change simultaneously with DQ5.

9.2 RY/BY#: Ready/Busy#

The RY/BY# is a dedicated, open-drain output pin that indicates whether an Embedded Algorithm is in progress or complete. The RY/BY# status is valid after the rising edge of the final WE# pulse in the command sequence. Since RY/BY# is an open-drain output, several RY/BY# pins can be tied together in parallel with a pull-up resistor to V_{CC}.

If the output is low (Busy), the device is actively erasing or programming. (This includes programming in the Erase Suspend mode.) If the output is high (Ready), the device is ready to read array data (including during the Erase Suspend mode), or is in the standby mode.

Table 9.1 on page 31 shows the outputs for RY/BY#. Figure 15.1 on page 36, Figure 15.2 on page 37, Figure 15.5 on page 39 and Figure 15.6 on page 40 shows RY/BY# for read, reset, program, and erase operations, respectively.

9.3 DQ6: Toggle Bit I

Toggle Bit I on DQ6 indicates whether an Embedded Program or Erase algorithm is in progress or complete, or whether the device entered the Erase Suspend mode. Toggle Bit I may be read at any address, and is valid after the rising edge of the final WE# pulse in the command sequence (prior to the program or erase operation), and during the sector erase time-out.

During an Embedded Program or Erase algorithm operation, successive read cycles to any address cause DQ6 to toggle. (The system may use either OE# or CE# to control the read cycles.) When the operation is complete, DQ6 stops toggling.

After an erase command sequence is written, if all sectors selected for erasing are protected, DQ6 toggles for approximately 100 μ s, then returns to reading array data. If not all selected sectors are protected, the Embedded Erase algorithm erases the unprotected sectors, and ignores the selected sectors that are protected.

The system can use DQ6 and DQ2 together to determine whether a sector is actively erasing or is erase-suspended. When the device is actively erasing (that is, the Embedded Erase algorithm is in progress), DQ6 toggles. When the device enters the Erase Suspend mode, DQ6 stops toggling. However, the system must also use DQ2 to determine which sectors are erasing or erase-suspended. Alternatively, the system can use DQ7 (see [DQ7: Data# Polling on page 27](#)).

If a program address falls within a protected sector, DQ6 toggles for approximately 1 μ s after the program command sequence is written, then returns to reading array data.

DQ6 also toggles during the erase-suspend-program mode, and stops toggling once the Embedded Program algorithm is complete.

[Table 9.1 on page 31](#) shows the outputs for Toggle Bit I on DQ6. [Figure 9.2 on page 30](#) shows the toggle bit algorithm. [Figure 15.9 on page 41](#) shows the toggle bit timing diagrams. [Figure 15.10 on page 42](#) shows the differences between DQ2 and DQ6 in graphical form. See also [DQ2: Toggle Bit II on page 29](#).

9.4 DQ2: Toggle Bit II

The *Toggle Bit II* on DQ2, when used with DQ6, indicates whether a particular sector is actively erasing (that is, the Embedded Erase algorithm is in progress), or whether that sector is erase-suspended. Toggle Bit II is valid after the rising edge of the final WE# pulse in the command sequence.

DQ2 toggles when the system reads at addresses within those sectors that were selected for erasure. (The system may use either OE# or CE# to control the read cycles.) But DQ2 cannot distinguish whether the sector is actively erasing or is erase-suspended. DQ6, by comparison, indicates whether the device is actively erasing, or is in Erase Suspend, but cannot distinguish which sectors are selected for erasure. Thus, both status bits are required for sector and mode information. Refer to [Table 9.1 on page 31](#) to compare outputs for DQ2 and DQ6.

[Figure 9.2 on page 30](#) shows the toggle bit algorithm in flowchart form, and [DQ2: Toggle Bit II on page 29](#) explains the algorithm. See also [DQ6: Toggle Bit I on page 28](#). [Figure 15.9 on page 41](#) shows the toggle bit timing diagram. [Figure 15.10 on page 42](#) shows the differences between DQ2 and DQ6 in graphical form.

9.5 Reading Toggle Bits DQ6/DQ2

Refer to [Figure 9.2 on page 30](#) for the following discussion. Whenever the system initially begins reading toggle bit status, it must read DQ7–DQ0 at least twice in a row to determine whether a toggle bit is toggling. Typically, the system would note and store the value of the toggle bit after the first read. After the second read, the system would compare the new value of the toggle bit with the first. If the toggle bit is not toggling, the device completed the program or erase operation. The system can read array data on DQ7–DQ0 on the following read cycle.

However, if after the initial two read cycles, the system determines that the toggle bit is still toggling, the system also should note whether the value of DQ5 is high (see [DQ5: Exceeded Timing Limits on page 30](#)). If it is, the system should then determine again whether the toggle bit is toggling, since the toggle bit may have stopped toggling just as DQ5 went high. If the toggle bit is no longer toggling, the device successfully completed the program or erase operation. If it is still toggling, the device did not complete the operation successfully, and the system must write the reset command to return to reading array data.

The remaining scenario is that the system initially determines that the toggle bit is toggling and DQ5 has not gone high. The system may continue to monitor the toggle bit and DQ5 through successive read cycles, determining the status as described in the previous paragraph. Alternatively, it may choose to perform other system tasks. In this case, the system must start at the beginning of the algorithm when it returns to determine the status of the operation (top of [Figure 9.2 on page 30](#)).

9.6 DQ5: Exceeded Timing Limits

DQ5 indicates whether the program or erase time exceeded a specified internal pulse count limit. Under these conditions DQ5 produces a **1**. This is a failure condition that indicates the program or erase cycle was not successfully completed.

The DQ5 failure condition may appear if the system tries to program a **1** to a location that is previously programmed to **0**. **Only an erase operation can change a 0 back to a 1**. Under this condition, the device halts the operation, and when the operation exceeds the timing limits, DQ5 produces a **1**.

Under both these conditions, the system must issue the reset command to return the device to reading array data.

9.7 DQ3: Sector Erase Timer

After writing a sector erase command sequence, the system may read DQ3 to determine whether or not an erase operation started. (The sector erase timer does not apply to the chip erase command.) If additional sectors are selected for erasure, the entire time-out also applies after each additional sector erase command. When the time-out is complete, DQ3 switches from **0** to **1**. The system may ignore DQ3 if the system can guarantee that the time between additional

sector erase commands is always less than 50 μ s. See also [Sector Erase Command Sequence on page 24](#).

Figure 9.2 Toggle Bit Algorithm

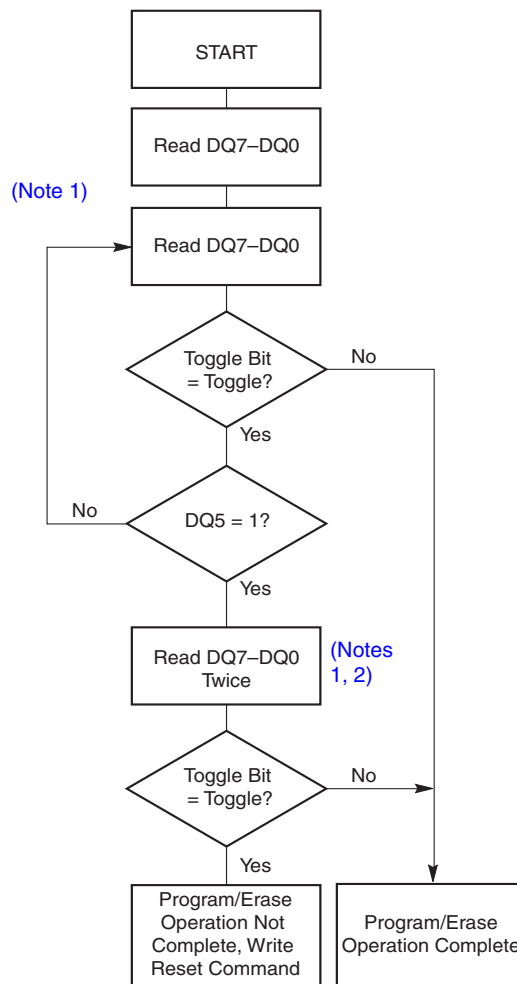

Notes

1. Read toggle bit twice to determine whether or not it is toggling. See text.
2. Recheck toggle bit because it may stop toggling as DQ5 changes to 1. See text.

After the sector erase command sequence is written, the system should read the status on DQ7 (Data# Polling) or DQ6 (Toggle Bit I) to ensure the device accepted the command sequence, and then read DQ3. If DQ3 is 1, the internally controlled erase cycle started; all further commands (other than Erase Suspend) are ignored until the erase operation is complete. If DQ3 is 0, the device accepts additional sector erase commands. To ensure the command is accepted, the system software should check the status of DQ3 prior to and following each subsequent sector erase command. If DQ3 is high on the second status check, the last command might not be accepted. Table 9.1 shows the outputs for DQ3.

Table 9.1 Write Operation Status

Operation		DQ7 (Note 2)	DQ6	DQ5 (Note 1)	DQ3	DQ2 (Note 2)	RY/BY#
Standard Mode	Embedded Program Algorithm	DQ7#	Toggle	0	N/A	No toggle	0
	Embedded Erase Algorithm	0	Toggle	0	1	Toggle	0
Erase Suspend Mode	Reading within Erase Suspended Sector	1	No toggle	0	N/A	Toggle	1
	Reading within Non-Erase Suspended Sector	Data	Data	Data	Data	Data	1
	Erase-Suspend-Program	DQ7#	Toggle	0	N/A	N/A	0

Notes

1. DQ5 switches to 1 when an Embedded Program or Embedded Erase operation exceeds the maximum timing limits. See [DQ5: Exceeded Timing Limits on page 30](#) for more information.
2. DQ7 and DQ2 require a valid address when reading status information. Refer to the appropriate subsection for further details.

10. Absolute Maximum Ratings

Parameter	Rating
Storage Temperature Plastic Packages	-65°C to +150°C
Ambient Temperature with Power Applied	-65°C to +125°C
Voltage with Respect to Ground V_{CC} (Note 1)	-0.5 V to +4.0 V
A9, OE#, and RESET# (Note 2)	-0.5 V to +12.5 V
All other pins (Note 1)	-0.5 V to $V_{CC}+0.5$ V
Output Short Circuit Current (Note 3)	200 mA

Notes

1. Minimum DC voltage on input or I/O pins is -0.5 V. During voltage transitions, input or I/O pins may undershoot V_{SS} to -2.0 V for periods of up to 20 ns. See [Figure 11.1 on page 32](#). Maximum DC voltage on input or I/O pins is $V_{CC}+0.5$ V. During voltage transitions, input or I/O pins may overshoot to $V_{CC}+2.0$ V for periods up to 20 ns. See [Figure 11.2 on page 32](#).
2. Minimum DC input voltage on pins A9, OE#, and RESET# is -0.5 V. During voltage transitions, A9, OE#, and RESET# may undershoot V_{SS} to -2.0 V for periods of up to 20 ns. See [Figure 11.1 on page 32](#). Maximum DC input voltage on pin A9 is +12.5 V which may overshoot to 14.0 V for periods up to 20 ns.
3. No more than one output may be shorted to ground at a time. Duration of the short circuit should not be greater than one second.
4. Stresses above those listed under "Absolute Maximum Ratings" may cause permanent damage to the device. This is a stress rating only; functional operation of the device at these or any other conditions above those indicated in the operational sections of this data sheet is not implied. Exposure of the device to absolute maximum rating conditions for extended periods may affect device reliability.

11. Operating Ranges

Industrial (I) Devices

Ambient Temperature (T_A) -40°C to +85°C

Extended (N) Devices

Ambient Temperature (T_A) -40°C to +125°C

V_{CC} Supply Voltages

V_{CC} for regulated voltage range +3.0 V to +3.6 V

V_{CC} for full voltage range +2.7 V to +3.6 V

Operating ranges define those limits between which the functionality of the device is guaranteed

Figure 11.1 Maximum Negative Overshoot Waveform

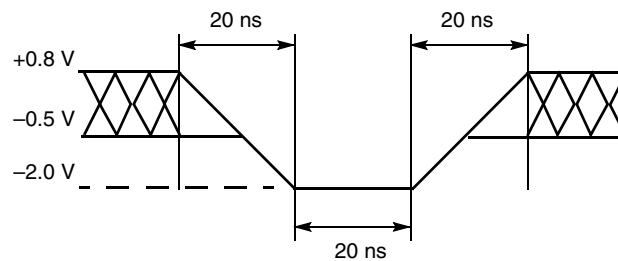
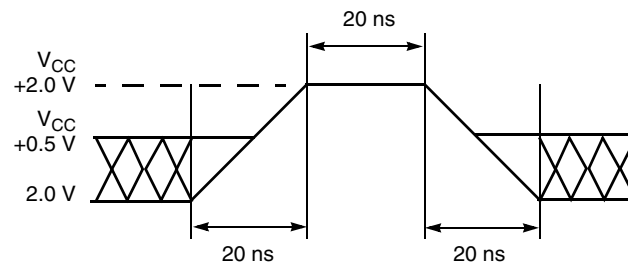

Figure 11.2 Maximum Positive Overshoot Waveform



12. DC Characteristics

Parameter	Description	Test Conditions	Min	Typ	Max	Unit	
I_{LI}	Input Load Current	$V_{IN} = V_{SS}$ to V_{CC} , $V_{CC} = V_{CC\ max}$			± 1.0	μA	
I_{LIT}	A9 Input Load Current	$V_{CC} = V_{CC\ max}$; A9 = 12.5 V			35	μA	
I_{LO}	Output Leakage Current	$V_{OUT} = V_{SS}$ to V_{CC} , $V_{CC} = V_{CC\ max}$			± 1.0	μA	
I_{CC1}	V_{CC} Active Read Current (Notes 1, 2)	CE# = V_{IL} , OE# = V_{IH} , Byte Mode	10 MHz		15	30	mA
			5 MHz		9	16	
			1 MHz		2	4	
		CE# = V_{IL} , OE# = V_{IH} , Word Mode	10 MHz		15	30	
			5 MHz		9	16	
			1 MHz		2	4	
I_{CC2}	V_{CC} Active Write Current (Notes 2, 3, 6)	CE# = V_{IL} , OE# = V_{IH}		20	35	mA	
I_{CC3}	V_{CC} Standby Current (Notes 2, 4)	CE#, RESET# = $V_{CC} \pm 0.3$ V		0.2	5	μA	
I_{CC4}	V_{CC} Reset Current (Notes 2, 4)	RESET# = $V_{SS} \pm 0.3$ V		0.2	5	μA	
I_{CC5}	Automatic Sleep Mode (Notes 2, 4, 5)	$V_{IH} = V_{CC} \pm 0.3$ V; $V_{IL} = V_{SS} \pm 0.3$ V		0.2	5	μA	
V_{IL}	Input Low Voltage		-0.5		0.8	V	
V_{IH}	Input High Voltage		$0.7 \times V_{CC}$		$V_{CC} + 0.3$	V	
V_{ID}	Voltage for Autoselect and Temporary Sector Unprotect	$V_{CC} = 3.3$ V	11.5		12.5	V	
V_{OL}	Output Low Voltage	$I_{OL} = 4.0$ mA, $V_{CC} = V_{CC\ min}$			0.45	V	
V_{OH1}	Output High Voltage	$I_{OH} = -2.0$ mA, $V_{CC} = V_{CC\ min}$	2.4			V	
V_{OH2}		$I_{OH} = -100$ μA , $V_{CC} = V_{CC\ min}$	$V_{CC} - 0.4$				
V_{LKO}	Low V_{CC} Lock-Out Voltage		2.3		2.5	V	

Notes

1. The I_{CC} current listed is typically less than 2 mA/MHz, with OE# at V_{IH} . Typical V_{CC} is 3.0 V.
2. Maximum I_{CC} specifications are tested with $V_{CC} = V_{CC\ max}$.
3. I_{CC} active while Embedded Erase or Embedded Program is in progress.
4. At extended temperature range (>+85°C), typical current is 5 μA and maximum current is 10 μA .
5. Automatic sleep mode enables the low power mode when addresses remain stable for $t_{ACC} + 30$ ns.
6. Not 100% tested.

12.1 Zero Power Flash

Figure 12.1 I_{CC1} Current vs. Time (Showing Active and Automatic Sleep Currents)

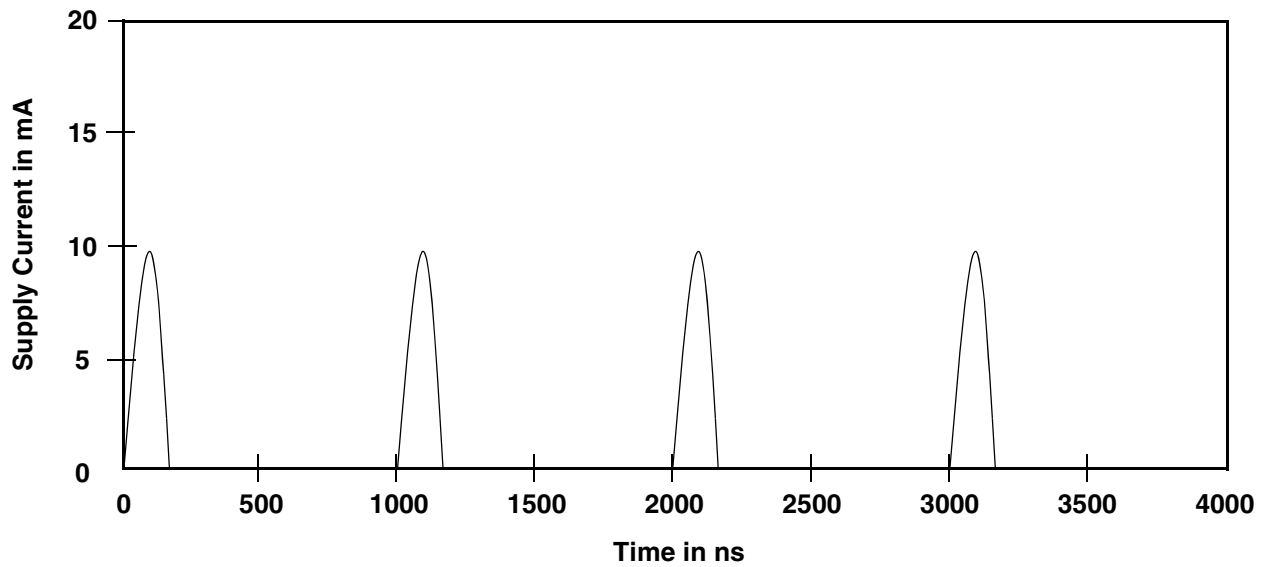

Note
Addresses are switching at 1 MHz

Figure 12.2 Typical I_{CC1} vs. Frequency

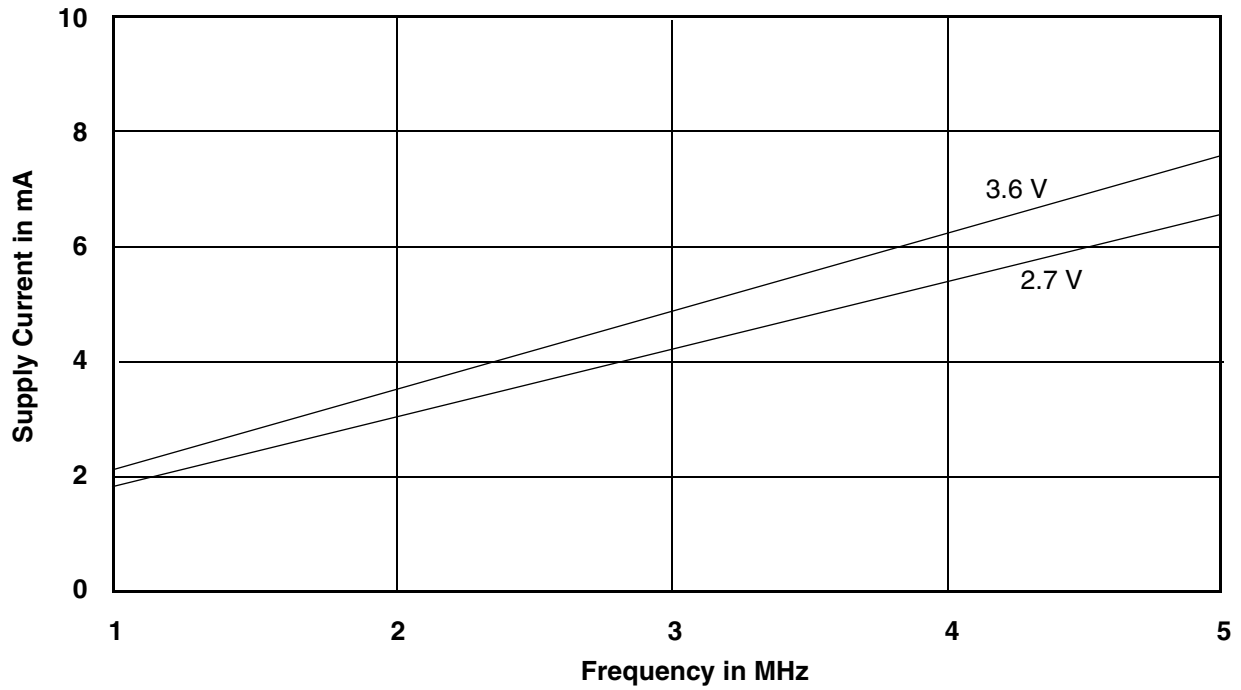

Note
 $T = 25^\circ\text{C}$

13. Test Conditions

Figure 13.1 Test Setup

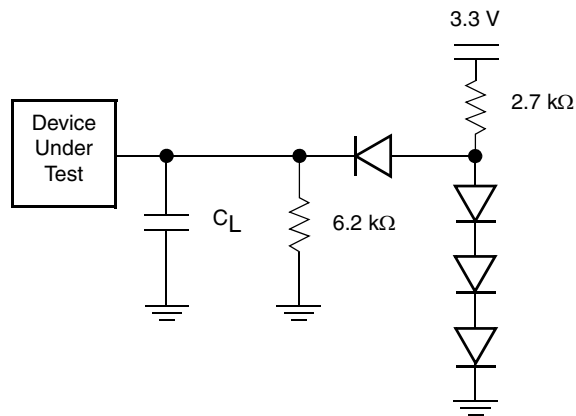

Note
Nodes are IN3064 or equivalent.

Table 13.1 Test Specifications

Test Condition	55	60	70	90	Unit
Output Load	1 TTL gate				
Output Load Capacitance, C_L (including jig capacitance)	30	30	30	100	pF
Input Rise and Fall Times	5				ns
Input Pulse Levels	0.0 or V_{CC}				V
Input timing measurement reference levels	0.5 V_{CC}				
Output timing measurement reference levels	0.5 V_{CC}				

14. Key to Switching Waveforms

Waveform	Inputs	Outputs
	Steady	
	Changing from H to L	
	Changing from L to H	
	Don't Care, Any Change Permitted	Changing, State Unknown
	Does Not Apply	Center Line is High Impedance State (High Z)

Figure 14.1 Input Waveforms and Measurement Levels

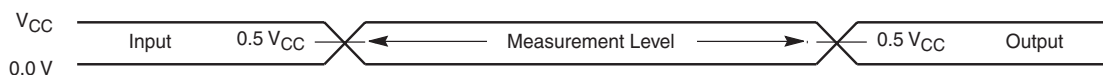

15. AC Characteristics

Table 15.1 Read Operations

Parameter		Description	Test Setup		Speed Options				Unit
JEDEC	Std				55	60	70	90	
t_{AVAV}	t_{RC}	Read Cycle Time (Note 1)		Min	55	60	70	90	ns
t_{AVQV}	t_{ACC}	Address to Output Delay	CE# = V_{IL} OE# = V_{IL}	Max	55	60	70	90	
t_{ELQV}	t_{CE}	Chip Enable to Output Delay	OE# = V_{IL}	Max	55	60	70	90	
t_{GLQV}	t_{OE}	Output Enable to Output Delay		Max	25	25	30	35	
t_{EHQZ}	t_{DF}	Chip Enable to Output High Z (Note 1)		Max	16				
t_{GHQZ}	t_{DF}	Output Enable to Output High Z (Note 1)		Max	16				
	t_{SRW}	Latency Between Read and Write Operations		Min	20				
	t_{OEh}	Output Enable Hold Time (Note 1)	Read	Min	0				
		Toggle and Data# Polling	Min	10					
t_{AXQX}	t_{OH}	Output Hold Time From Addresses, CE# or OE#, Whichever Occurs First (Note 1)		Min	0				

Notes

1. Not 100% tested.
2. See Figure 13.1 on page 35 and DC Characteristics on page 33 for test specifications.

Figure 15.1 Read Operations Timings

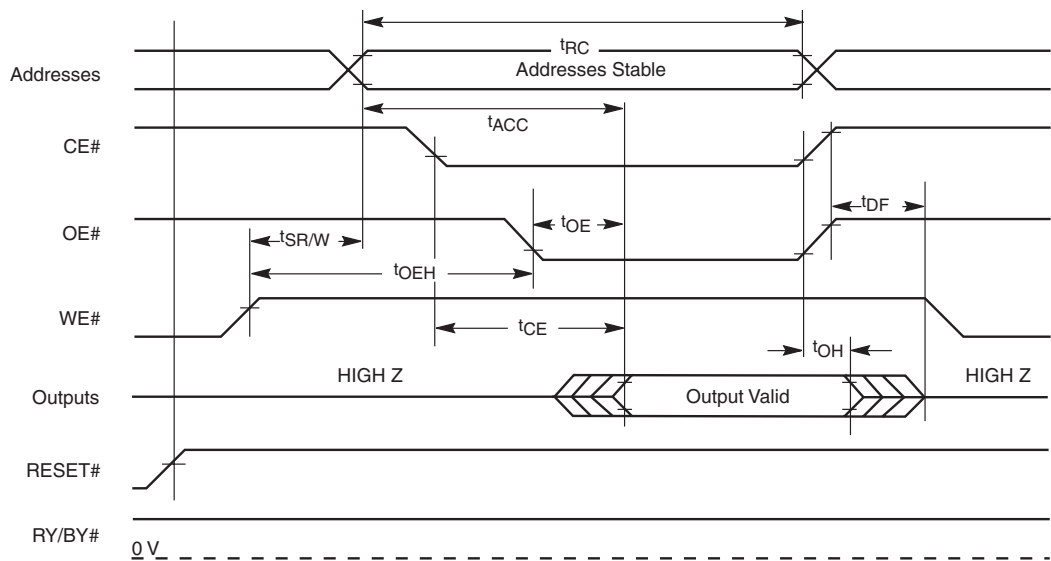

Table 15.2 Hardware Reset (RESET#)

Parameter		Description	Test Setup	All Speed Options	Unit
JEDEC	Std				
	t_{READY}	RESET# Pin Low (During Embedded Algorithms) to Read or Write (See Note)	Max	20	μs
	t_{READY}	RESET# Pin Low (NOT During Embedded Algorithms) to Read or Write (See Note)		500	ns
	t_{RP}	RESET# Pulse Width	Min	500	
	t_{RH}	RESET# High Time Before Read (See Note)		50	
	t_{RPD}	RESET# Low to Standby Mode		20	μs
	t_{RB}	RY/BY# Recovery Time		0	ns

Note
Not 100% tested.

Figure 15.2 RESET# Timings

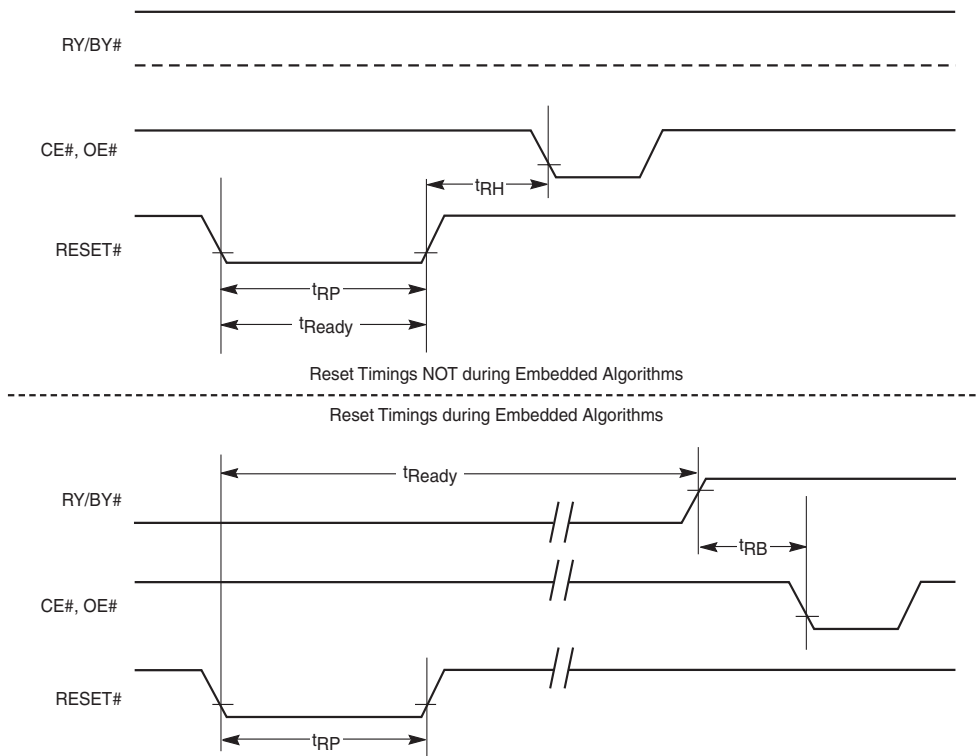

Table 15.3 Word/Byte Configuration (BYTE#)

Parameter		Description		Speed Options				Unit
JEDEC	Std			55	60	70	90	
	$t_{ELFL}^{\wedge}t_{ELFH}$	CE# to BYTE# Switching Low or High	Max	5				ns
	t_{FLOZ}	BYTE# Switching Low to Output HIGH Z	Max	16				
	t_{FHQV}	BYTE# Switching High to Output Active	Min	55	60	70	90	

Figure 15.3 BYTE# Timings for Read Operations

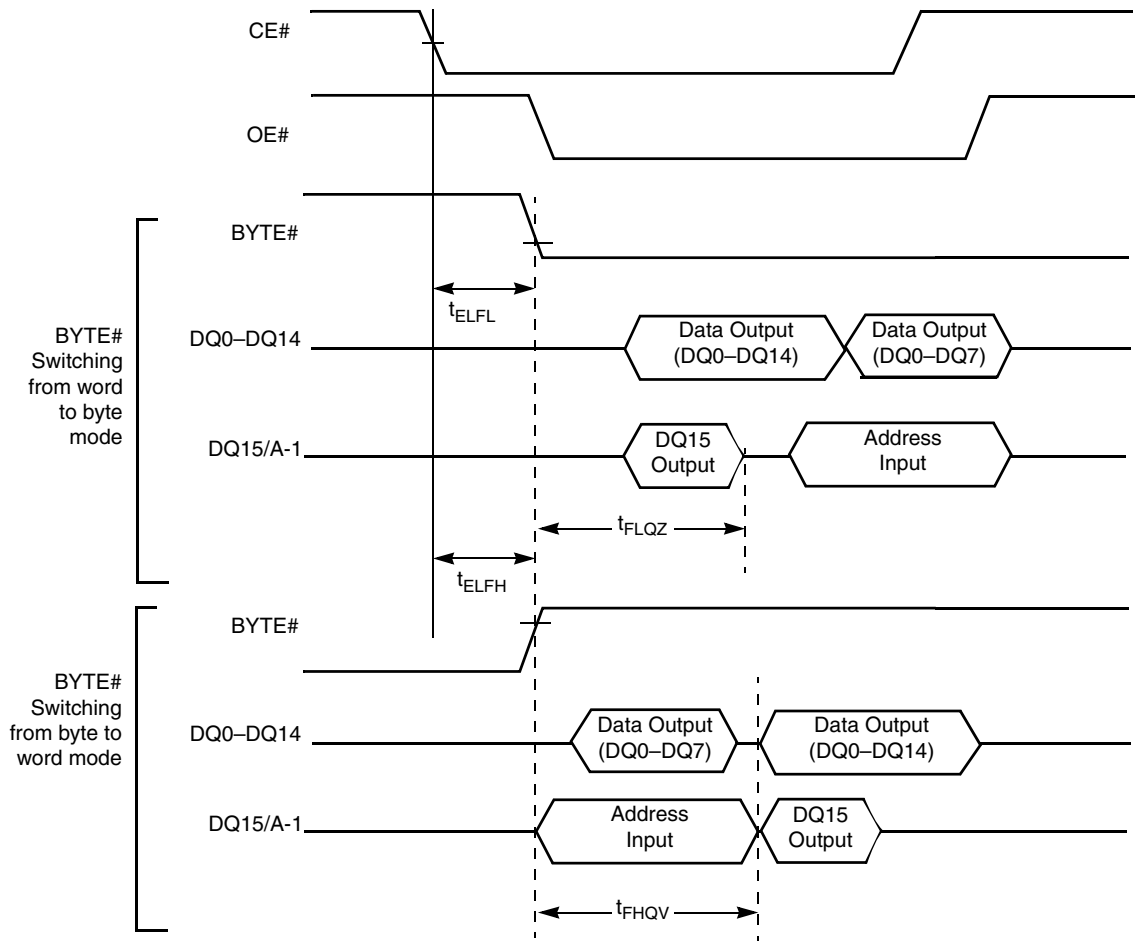
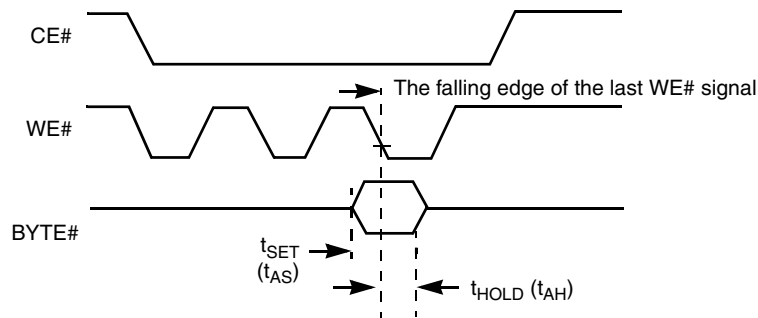

Figure 15.4 BYTE# Timings for Write Operations



Note
Refer to *Erase/Program Operations* on page 39 for t_{AS} and t_{AH} specifications.

15.1 Erase/Program Operations

Parameter		Description	Speed Options				Unit		
JEDEC	Std		55	60	70	90			
t_{AVAV}	t_{WC}	Write Cycle Time (Note 1)	55	60	70	90	ns		
t_{AVWL}	t_{AS}		0						
t_{WLAX}	t_{AH}		45						
t_{DVWH}	t_{DS}		35	35	35	45			
t_{WHDX}	t_{DH}		0						
	t_{OES}		0						
t_{GHWL}	t_{GHWL}		0						
t_{ELWL}	t_{CS}		0						
t_{WHEH}	t_{CH}		0						
t_{WLWH}	t_{WP}		35						
t_{WHWL}	t_{WPH}		30						
	$t_{SR/W}$		20						
t_{WHWH1}	t_{WHWH1}		Programming Operation (Note 2)	7				μ s	
				Byte					
		Word	7						
t_{WHWH2}	t_{WHWH2}	Sector Erase Operation (Note 2)	0.7				sec		
	t_{VCS}	V_{CC} Setup Time (Note 1)	50				μ s		
	t_{RB}	Recovery Time from RY/BY#	0				ns		
	t_{BUSY}	Program/Erase Valid to RY/BY# Delay	90						

Notes

1. Not 100% tested.
2. See [Erase and Programming Performance on page 44](#) for more information.

Figure 15.5 Program Operation Timings

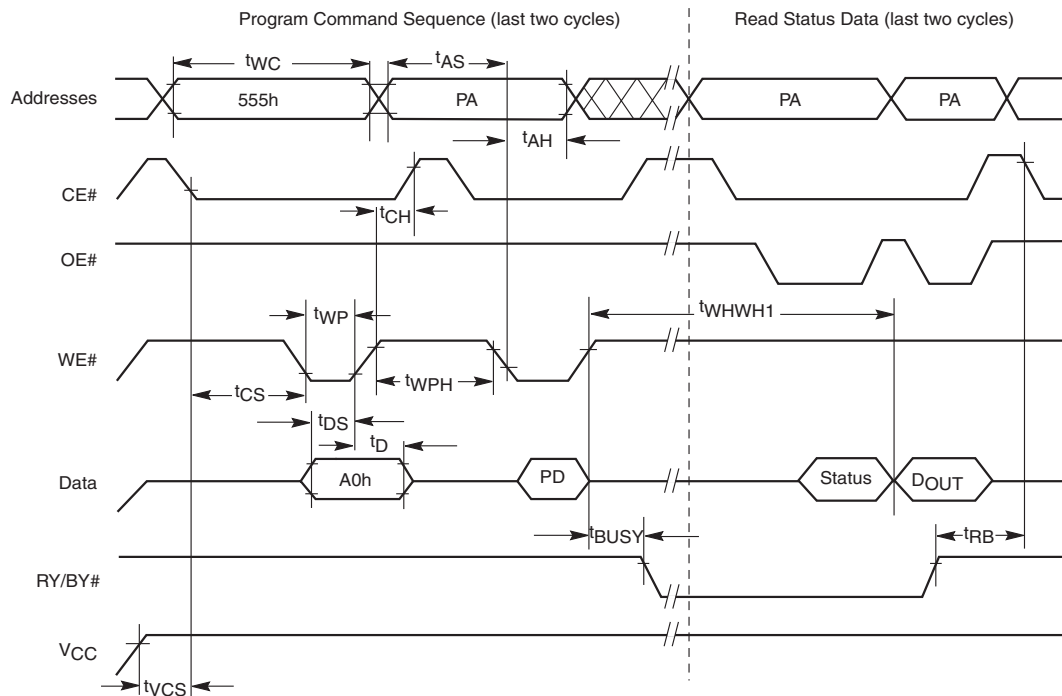

Notes

1. PA = program address, PD = program data, D_{OUT} is the true data at the program address.
2. Illustration shows device in word mode

Figure 15.6 Chip/Sector Erase Operation Timings

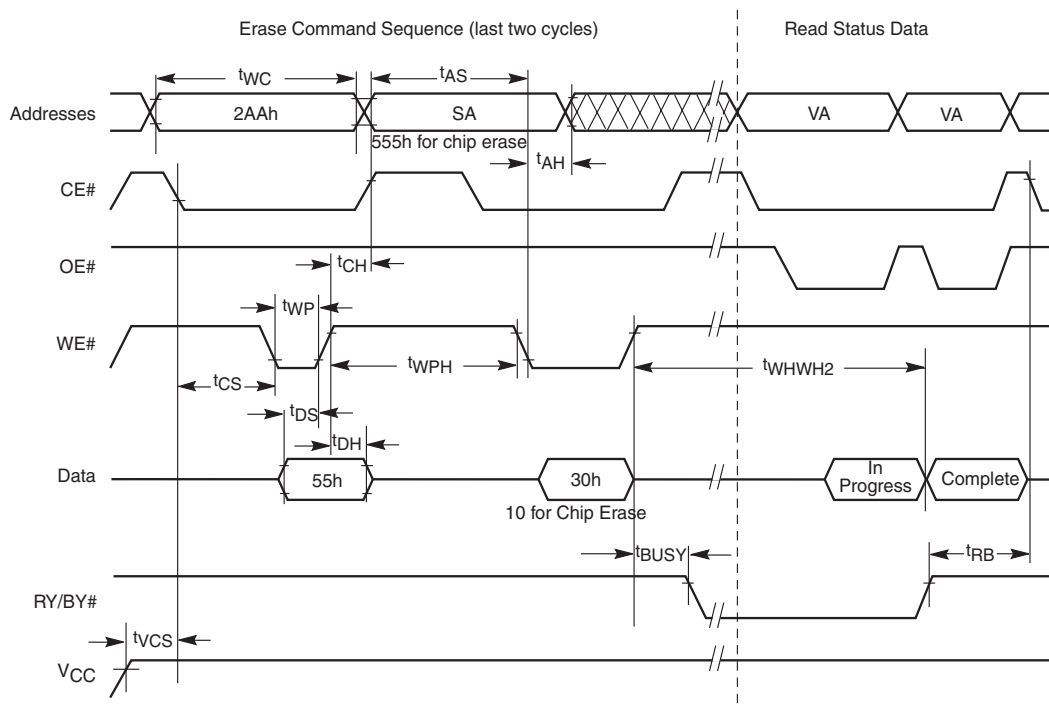

Notes

1. SA = sector address (for Sector Erase), VA = Valid Address for reading status data (see [Write Operation Status on page 27](#)).
2. Illustration shows device in word mode.

Figure 15.7 Back to Back Read/Write Cycle Timing

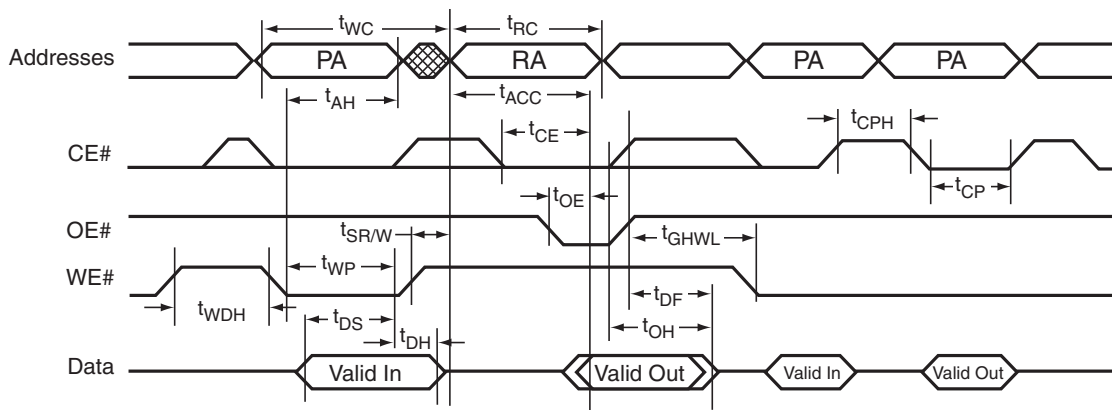
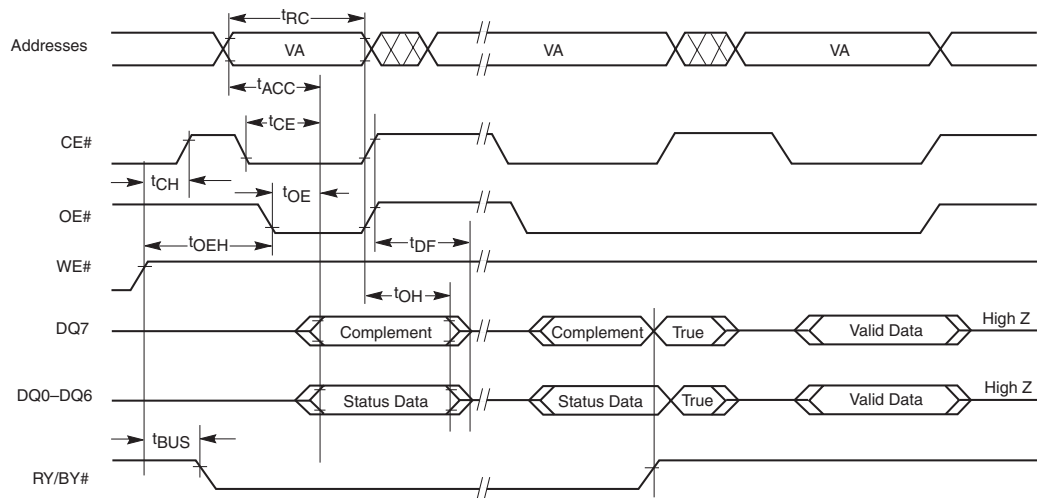

Figure 15.8 Data# Polling Timings (During Embedded Algorithms)



Note

VA = Valid address. Illustration shows first status cycle after command sequence, last status read cycle, and array data read cycle

Figure 15.9 Toggle Bit Timings (During Embedded Algorithms)

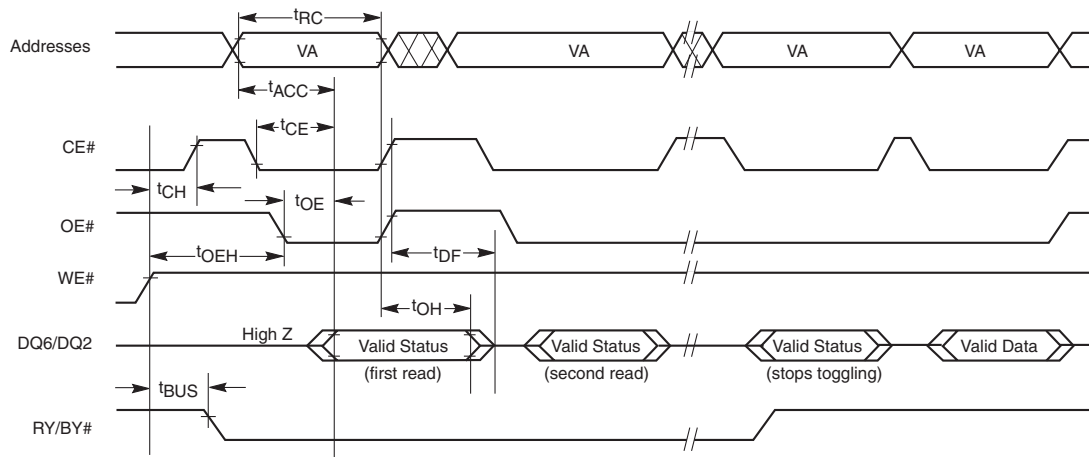

Note

VA = Valid address; not required for DQ6. Illustration shows first two status cycle after command sequence, last status read cycle, and array data read cycle.

Figure 15.10 DQ2 vs. DQ6

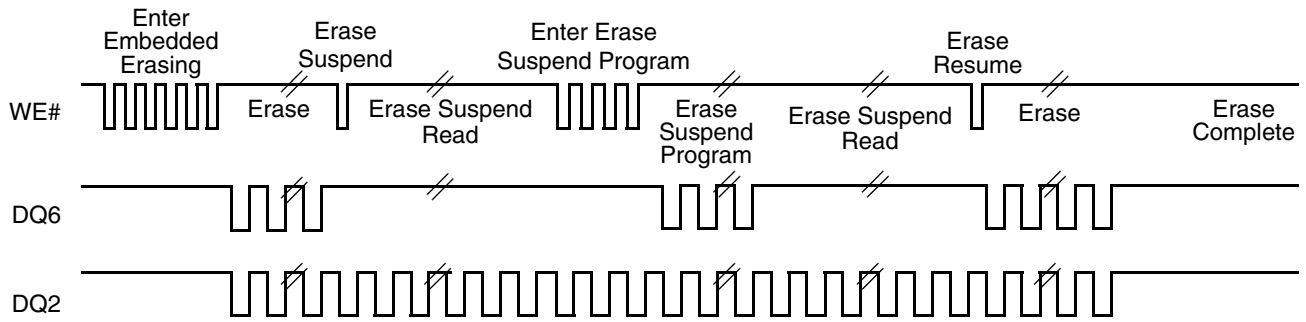

Note

The system may use CE# or OE# to toggle DQ2 and DQ6. DQ2 toggles only when read at an address within an erase-suspended sector.

Table 15.4 Temporary Sector Unprotect

Parameter		Description		All Speed Options	Unit
JEDEC	Std				
	t_{VIDR}	V_{ID} Rise and Fall Time (See Note)	Min	500	ns
	t_{RSP}	RESET# Setup Time for Temporary Sector Unprotect	Min	4	μ s

Note

Not 100% tested.

Figure 15.11 Temporary Sector Unprotect Timing Diagram

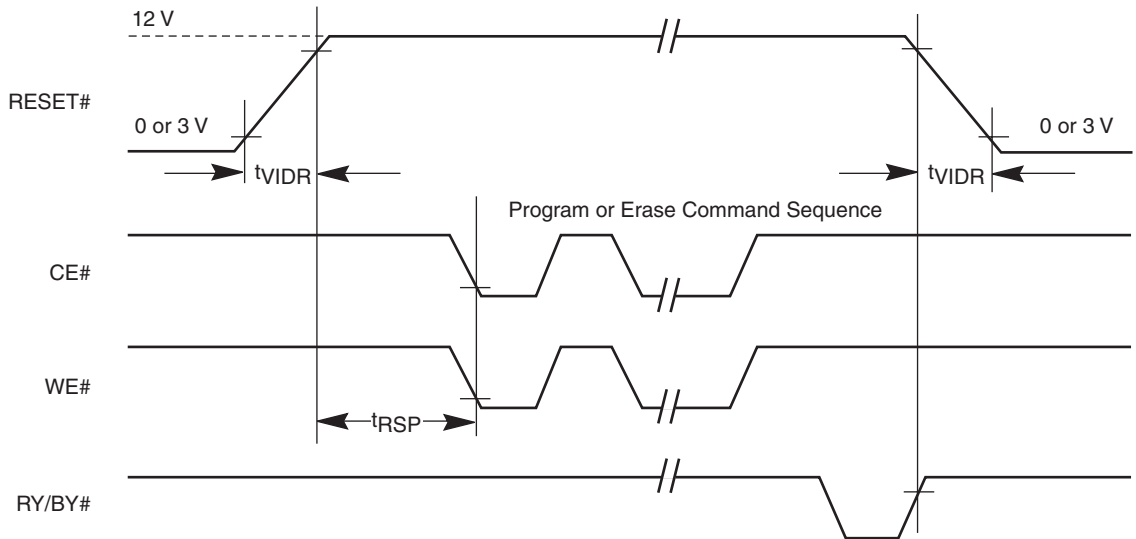
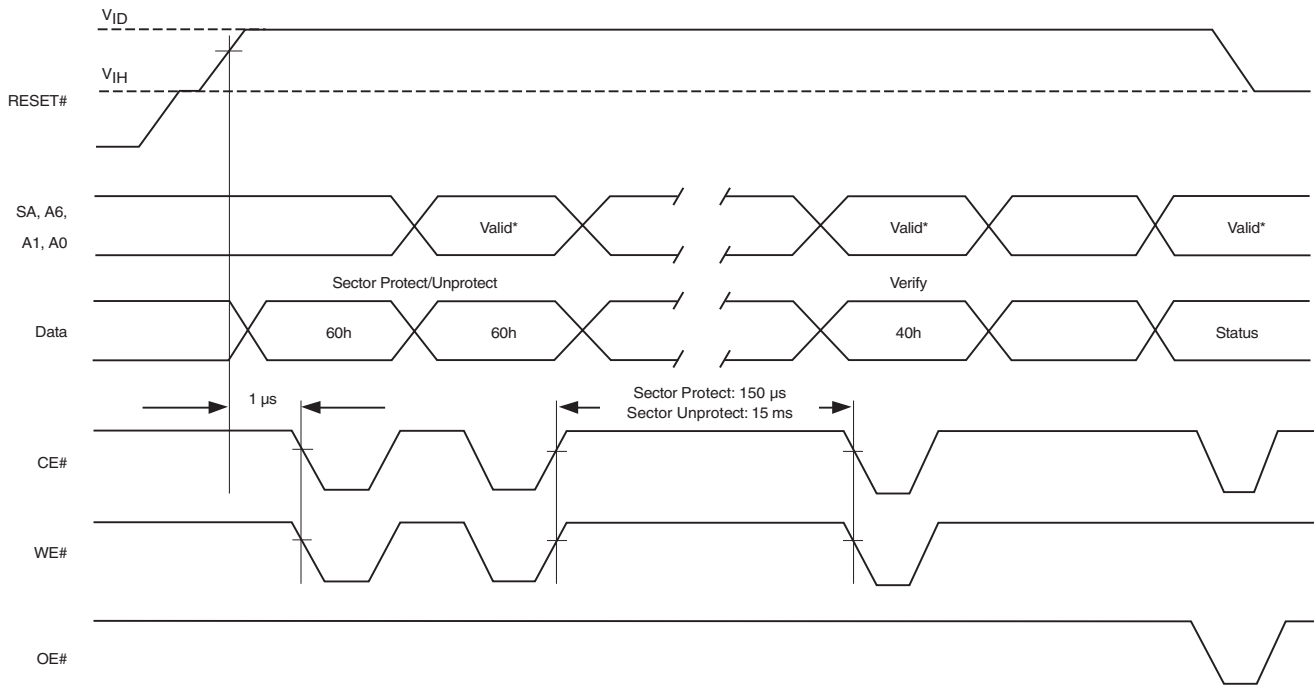

Figure 15.12 Sector Protect/Unprotect Timing Diagram



Note
 For sector protect, A6 = 0, A1 = 1, A0 = 0. For sector unprotect, A6 = 1, A1 = 1, A0 = 0.

Table 15.5 Alternate CE# Controlled Erase/Program Operations

Parameter		Description	Speed Options				Unit
JEDEC	Std		55	60	70	90	
t _{AVAV}	t _{WC}	Write Cycle Time (Note 1)	55	60	70	90	ns
t _{AVEL}	t _{AS}	Address Setup Time	0				
t _{ELAX}	t _{AH}	Address Hold Time	45				
t _{DVEH}	t _{DS}	Data Setup Time	35	35	35	45	
t _{EHDH}	t _{DH}	Data Hold Time	0				
	t _{OES}	Output Enable Setup Time	0				
t _{GHHL}	t _{GHHL}	Read Recovery Time Before Write (OE# High to WE# Low)	0				
t _{WLEL}	t _{WS}	WE# Setup Time	0				
t _{EHWL}	t _{WH}	WE# Hold Time	0				
t _{ELEH}	t _{CP}	CE# Pulse Width	35				
t _{EHEL}	t _{CPH}	CE# Pulse Width High	30				
	t _{SR/W}	Latency Between Read and Write Operations	20				ns
t _{WHWH1}	t _{WHWH1}	Programming Operation (Note 2)	7				μs
			Byte				
t _{WHWH2}	t _{WHWH2}	Sector Erase Operation (Note 2)	0.7				sec

- Notes**
- Not 100% tested.
 - See Erase and Programming Performance on page 44 for more information.

Figure 15.13 Alternate CE# Controlled Write Operation Timings

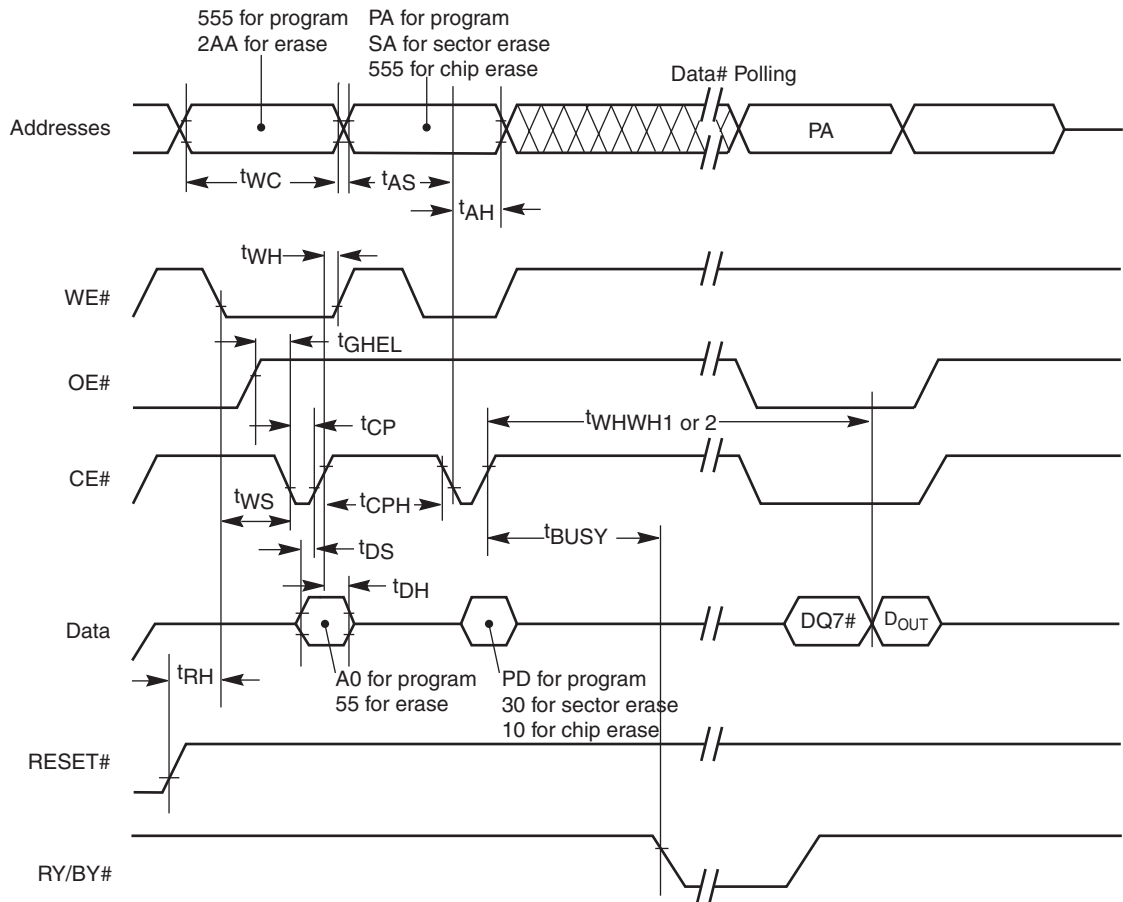

Notes

1. PA = program address, PD = program data, DQ7# = complement of the data written to the device, D_{OUT} = data written to the device.
2. Figure indicates the last two bus cycles of command sequence.
3. Word mode address used as an example.

15.2 Erase and Programming Performance

Parameter	Typ (Note 1)	Max (Note 2)	Unit	Comments
Sector Erase Time	0.7	10	s	Excludes 00h programming prior to erasure
Chip Erase Time	14		s	
Byte Programming Time	7	210	μs	Excludes system level overhead (Note 5)
Word Programming Time	7	210	μs	
Chip Programming Time (Note 3)				
	Byte Mode	8.4	25	s
	Word Mode	5.8	17	s

Notes

1. Typical program and erase times assume the following conditions: 25°C, 3.0 V V_{CC}, 1,000,000 cycles. Additionally, programming typicals assume checkerboard pattern.
2. Under worst case conditions of 90°C, V_{CC} = 2.7 V, 1,000,000 cycles.
3. The typical chip programming time is considerably less than the maximum chip programming time listed, since most bytes program faster than the maximum program times listed.
4. In the pre-programming step of the Embedded Erase algorithm, all bytes are programmed to 00h before erasure.
5. System-level overhead is the time required to execute the two- or four-bus-cycle sequence for the program command. See Table 8.1 on page 26 for further information on command definitions.
6. The device has a guaranteed minimum erase and program cycle endurance of 1,000,000 cycles.

Table 15.6 Latchup Characteristics

Description	Min	Max
Input voltage with respect to V_{SS} on all pins except I/O pins (including A9, OE#, and RESET#)	-1.0 V	12.5 V
Input voltage with respect to V_{SS} on all I/O pins	-1.0 V	$V_{CC} + 1.0$ V
V_{CC} Current	-100 mA	+100 mA

Note

Includes all pins except V_{CC} . Test conditions: $V_{CC} = 3.0$ V, one pin at a time.

Table 15.7 TSOP, SO, and BGA Pin Capacitance

Parameter Symbol	Parameter Description	Test Setup	Package	Typ	Max	Unit
C_{IN}	Input Capacitance	$V_{IN} = 0$	TSOP, SO	6	7.5	pF
			BGA	4.2	5.0	
C_{OUT}	Output Capacitance	$V_{OUT} = 0$	TSOP, SO	8.5	12	
			BGA	5.4	6.5	
C_{IN2}	Control Pin Capacitance	$V_{IN} = 0$	TSOP, SO	7.5	9	
			BGA	3.9	4.7	

Notes

1. Sampled, not 100% tested.
2. Test conditions $T_A = 25^\circ\text{C}$, $f = 1.0$ MHz.

16. Physical Dimensions

16.1 TS 048—48-Pin Standard TSOP

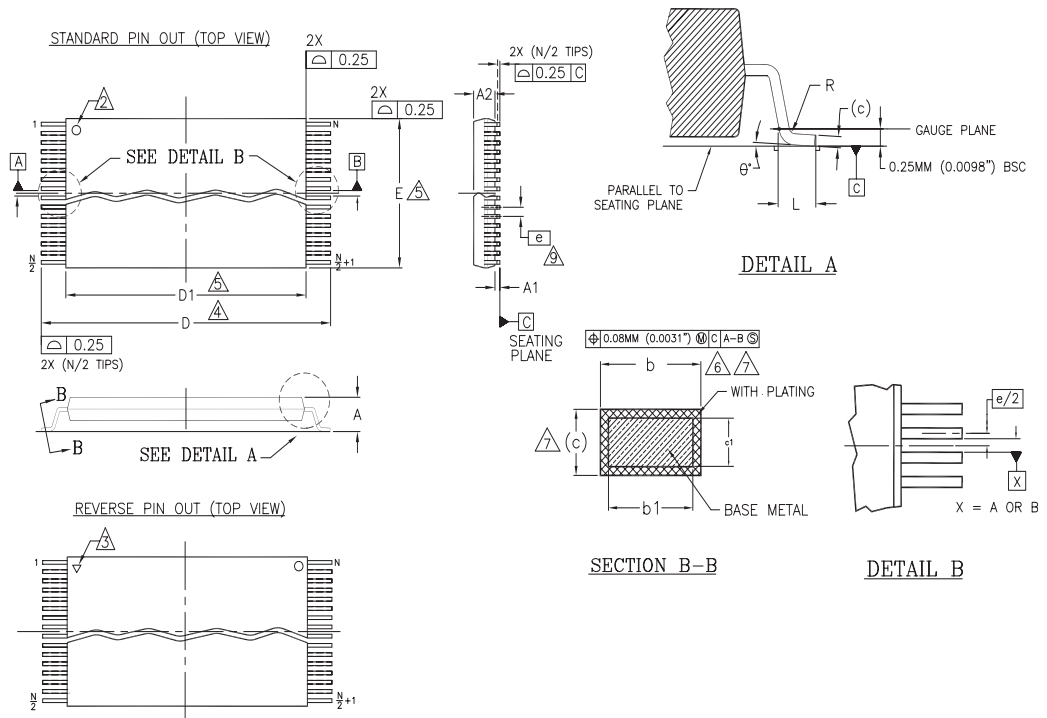

PACKAGE	TS/TSR 48		
	MO-142 (B) DD		
SYMBOL	MIN	NOM	MAX
A	---	---	1.20
A1	0.05	---	0.15
A2	0.95	1.00	1.05
b1	0.17	0.20	0.23
b	0.17	0.22	0.27
c1	0.10	---	0.16
c	0.10	---	0.21
D	19.80	20.00	20.20
D1	18.30	18.40	18.50
E	11.90	12.00	12.10
e	0.50 BASIC		
L	0.50	0.60	0.70
Θ	0°	---	8
R	0.08	---	0.20
N	48		

NOTES:

1. CONTROLLING DIMENSIONS ARE IN MILLIMETERS (mm). (DIMENSIONING AND TOLERANCING CONFORM TO ANSI Y14.5M-1982)
2. PIN 1 IDENTIFIER FOR STANDARD PIN OUT (DIE UP).
3. PIN 1 IDENTIFIER FOR REVERSE PIN OUT (DIE DOWN): INK OR LASER MARK.
4. TO BE DETERMINED AT THE SEATING PLANE \square -C-. THE SEATING PLANE IS DEFINED AS THE PLANE OF CONTACT THAT IS MADE WHEN THE PACKAGE LEADS ARE ALLOWED TO REST FREELY ON A FLAT HORIZONTAL SURFACE.
5. DIMENSIONS D1 AND E DO NOT INCLUDE MOLD PROTRUSION. ALLOWABLE MOLD PROTRUSION IS 0.15mm (0.0059") PER SIDE.
6. DIMENSION b DOES NOT INCLUDE DAMBAR PROTRUSION. ALLOWABLE DAMBAR PROTRUSION SHALL BE 0.08mm (0.0031") TOTAL IN EXCESS OF b DIMENSION AT MAX. MATERIAL CONDITION. MINIMUM SPACE BETWEEN PROTRUSION AND AN ADJACENT LEAD TO BE 0.07mm (0.0028").
7. THESE DIMENSIONS APPLY TO THE FLAT SECTION OF THE LEAD BETWEEN 0.10mm (0.0039") AND 0.25mm (0.0098") FROM THE LEAD TIP.
8. LEAD COPLANARITY SHALL BE WITHIN 0.10mm (0.004") AS MEASURED FROM THE SEATING PLANE.
9. DIMENSION "e" IS MEASURED AT THE CENTERLINE OF THE LEADS.

3841 | 16-038.10 | 7.10.7

Note

For reference only. BSC is an ANSI standard for Basic Space Centering.

16.2 VBK 048—48 Ball Fine-Pitch Ball Grid Array (FBGA) 8.15 x 6.15 mm

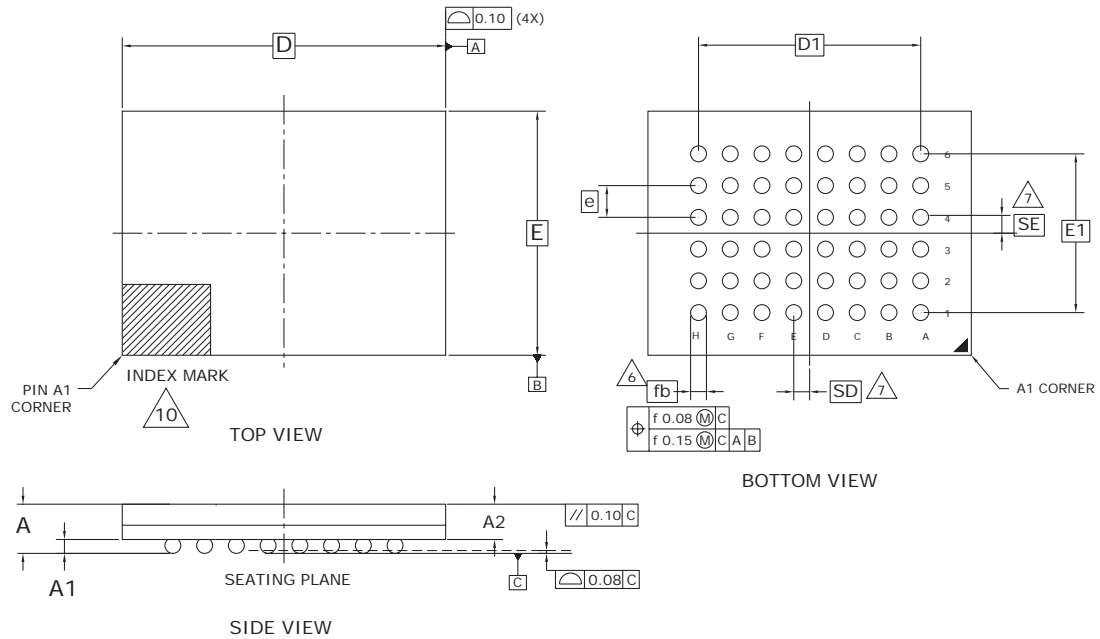

PACKAGE	VBK 048			NOTE
JEDEC	N/A			
	6.15 mm x 8.15 mm NOM PACKAGE			
SYMBOL	MIN	NOM	MAX	NOTE
A	---	---	1.00	OVERALL THICKNESS
A1	0.18	---	---	BALL HEIGHT
A2	0.62	---	0.76	BODY THICKNESS
D	8.15 BSC.			BODY SIZE
E	6.15 BSC.			BODY SIZE
D1	5.60 BSC.			BALL FOOTPRINT
E1	4.00 BSC.			BALL FOOTPRINT
MD	8			ROW MATRIX SIZE D DIRECTION
ME	6			ROW MATRIX SIZE E DIRECTION
N	48			TOTAL BALL COUNT
fb	0.35	---	0.43	BALL DIAMETER
e	0.80 BSC.			BALL PITCH
SD / SE	0.40 BSC.			SOLDER BALL PLACEMENT
	---			DEPOPULATED SOLDER BALLS

NOTES:

- DIMENSIONING AND TOLERANCING PER ASME Y14.5M-1994.
- ALL DIMENSIONS ARE IN MILLIMETERS.
- BALL POSITION DESIGNATION PER JESD 95-1, SPP-010 (EXCEPT AS NOTED).
- [e] REPRESENTS THE SOLDER BALL GRID PITCH.
- SYMBOL "MD" IS THE BALL ROW MATRIX SIZE IN THE "D" DIRECTION.
SYMBOL "ME" IS THE BALL COLUMN MATRIX SIZE IN THE "E" DIRECTION.
N IS THE TOTAL NUMBER OF SOLDER BALLS.
- △ DIMENSION "b" IS MEASURED AT THE MAXIMUM BALL DIAMETER IN A PLANE PARALLEL TO DATUM C.
- △ SD AND SE ARE MEASURED WITH RESPECT TO DATUMS A AND B AND DEFINE THE POSITION OF THE CENTER SOLDER BALL IN THE OUTER ROW.
WHEN THERE IS AN ODD NUMBER OF SOLDER BALLS IN THE OUTER ROW PARALLEL TO THE D OR E DIMENSION, RESPECTIVELY, SD OR SE = 0.000.
WHEN THERE IS AN EVEN NUMBER OF SOLDER BALLS IN THE OUTER ROW, SD OR SE = $\frac{e}{2}$
- NOT USED.
- "+" INDICATES THE THEORETICAL CENTER OF DEPOPULATED BALLS.
- △ A1 CORNER TO BE IDENTIFIED BY CHAMFER, LASER OR INK MARK, METALLIZED MARK INDENTATION OR OTHER MEANS.

3338 \ 16-038.25b

16.3 SO 044—44-Pin Small Outline Package

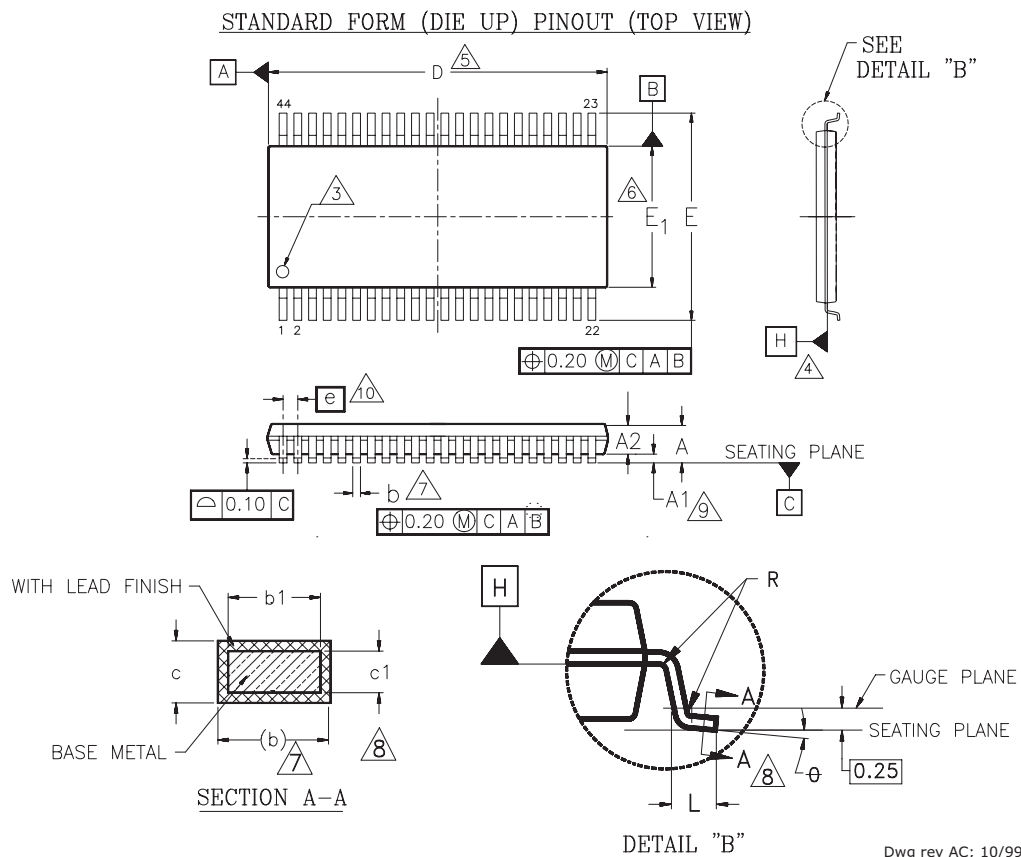

PACKAGE	SO 044		
JEDEC	MO-180 (A) AA		
SYMBOL	MIN	NDM	MAX
A	—	—	2.80
A1	0.15	0.23	0.35
A2	2.17	2.30	2.45
b	0.35	—	0.50
b1	0.35	0.40	0.45
c	0.10	—	0.21
c1	0.10	0.15	0.18
D	28.00	28.20	28.40
E	15.70	16.00	16.30
E1	13.10	13.30	13.50
e	1.27 BSC		
L	0.60	0.80	1.00
R	0.09	—	—
θ	0°	4°	8°

NOTES:

1. CONTROLLING DIMENSIONS ARE IN MILLIMETERS (mm).
2. DIMENSIONING AND TOLERANCING CONFORM TO ASME Y14.5M-1994.
3. PIN 1 IDENTIFIER FOR STANDARD FORM (DIE UP) OR REVERSE FORM (DIE DOWN) PINOUTS.
4. DATUMS A AND B AND DIMENSIONS D AND E1 ARE DETERMINED AT DATUM H.
5. DIMENSION "b" DOES NOT INCLUDE MOLD FLASH, PROTRUSIONS OR GATE BURRS. MOLD FLASH, PROTRUSIONS OR GATE BURRS SHALL NOT EXCEED 0.15 mm PER END.
6. DIMENSION "E1" DOES NOT INCLUDE INTERLEAD FLASH OR PROTRUSION. INTERLEAD FLASH OR PROTRUSION SHALL NOT EXCEED 0.25 mm PER SIDE.
7. DIMENSION b DOES NOT INCLUDE DAMBAR PROTRUSION/INTRUSION. ALLOWABLE DAMBAR PROTRUSION SHALL NOT EXCEED 0.15 mm PER SIDE. DAMBAR INTRUSION SHALL NOT REDUCE DIMENSION b BY MORE THAN 0.07 mm AT LEAST MATERIAL CONDITION.
8. THESE DIMENSIONS APPLY TO THE FLAT SECTION OF THE LEAD BETWEEN 0.10 mm AND 0.25 mm FROM THE LEAD TIPS.
9. A1 IS DEFINED AS THE DISTANCE FROM THE SEATING PLANE TO THE LOWEST POINT OF THE PACKAGE.
10. DIMENSION "e" IS MEASURED AT THE CENTERLINE OF THE LEADS.
11. LEAD COPLANARITY SHALL BE WITHIN 0.10 mm AS MEASURED FROM THEIR SEATING PLANE.

17. Revision History

17.1 Revision A (September 8, 2004)

Initial release

17.2 Revision A 1 (February 18, 2005)

Global

Updated Trademark

Ordering Information

Added Package type designator

Valid Combinations

Changed Package Type, Material, and Temperature Range designator

Under Package Descriptions, change SSOP to SOP

17.3 Revision A2 (June 1, 2005)

Global

Updated status from Advance Information to Preliminary data sheet.

Distinctive Characteristics

Updated manufactured process technology. Updated high performance access time. Added extended temperature range. Added cycling endurance information.

Production Selector Guide

Added 55 ns speed option and column.

Ordering Information

Added tube and tray packing types. Added extended temperature range Added model numbers.

Valid Combinations Table

Added speed option. Added packing types. Added model number. Added note for this table.

Operating Range

Added extended temperature range information.

Test Conditions

Added 55ns speed option.

AC Characteristics

Read Operation Table: Added 55ns speed option.

Word/Byte Configuration Table: Added 55 ns speed option.

Erase/Program Operation Table: Added 55ns speed option.

Alternate CE# Controlled Erase/Program Operation Table: Added 55 ns speed option.

Erase and Programming Performance: Changed Byte Programming Time values for Typical and Maximum.

17.4 Revision A3 (June 16, 2005)

Changed from Preliminary to full Data Sheet. Updated Valid Combinations table.

17.5 Revision A4 (February 16, 2006)

Corrected minor typo on page 1. Added cover page.

17.6 Revision A5 (May 22, 2006)

AC Characteristics

Added $t_{SR/W}$ parameter to read and erase/program operations tables. Added back-to-back read/write cycle timing diagram. Changed maximum value for t_{DF} and t_{FLOZ} .

17.7 Revision A6 (September 6, 2006)

Global

Added 60 ns speed option.

17.8 Revision A7 (October 31, 2006)

Automatic Sleep Mode

Changed I_{CC4} to I_{CC5} in description.

AC Characteristics, Erase / Program Operations

Changed t_{BUSY} to a maximum value.

17.9 Revision A8 (August 29, 2007)

TS048 Physical dimensions

Changed Revision from AA to E: changed degrees (max) from 5 to 8

17.10 Revision A9 (September 19, 2007)

Product Selector Guide

Changed TOE for 55ns access speed

Autoselect Codes Table

Changed part references to AL008D

Added A3 to A2 column

Command Definitions Table

Added F0 as an alternative 2nd cycle command for Unlock Bypass Reset

Test Specifications Table

Added $CL = 30$ pF under 60 ns access speed

Changed Input Pulse Levels, Input and Output timing measurement reference levels

Erase/Program Operations Table

Changed value of Programming Operation for Byte mode

Alternate CE# Controlled Erase/Program Operations Table

Changed values of Program Operation for both Byte & Word modes

Changed value of Sector Erase Operation

17.11 Revision A10 (November 27, 2007)

Figure: Input Waveforms and Measurement Levels

Updated figure

17.12 Revision A11 (February 27, 2009)

Global

Added obsolescence information to Cover Sheet, Distinctive Characteristics, and Ordering Information sections of data sheet.

Colophon

The products described in this document are designed, developed and manufactured as contemplated for general use, including without limitation, ordinary industrial use, general office use, personal use, and household use, but are not designed, developed and manufactured as contemplated (1) for any use that includes fatal risks or dangers that, unless extremely high safety is secured, could have a serious effect to the public, and could lead directly to death, personal injury, severe physical damage or other loss (i.e., nuclear reaction control in nuclear facility, aircraft flight control, air traffic control, mass transport control, medical life support system, missile launch control in weapon system), or (2) for any use where chance of failure is intolerable (i.e., submersible repeater and artificial satellite). Please note that Spansion will not be liable to you and/or any third party for any claims or damages arising in connection with above-mentioned uses of the products. Any semiconductor devices have an inherent chance of failure. You must protect against injury, damage or loss from such failures by incorporating safety design measures into your facility and equipment such as redundancy, fire protection, and prevention of over-current levels and other abnormal operating conditions. If any products described in this document represent goods or technologies subject to certain restrictions on export under the Foreign Exchange and Foreign Trade Law of Japan, the US Export Administration Regulations or the applicable laws of any other country, the prior authorization by the respective government entity will be required for export of those products.

Trademarks and Notice

The contents of this document are subject to change without notice. This document may contain information on a Spansion product under development by Spansion. Spansion reserves the right to change or discontinue work on any product without notice. The information in this document is provided as is without warranty or guarantee of any kind as to its accuracy, completeness, operability, fitness for particular purpose, merchantability, non-infringement of third-party rights, or any other warranty, express, implied, or statutory. Spansion assumes no liability for any damages of any kind arising out of the use of the information in this document.

Copyright © 2004-2009 Spansion Inc. All rights reserved. Spansion®, the Spansion Logo, MirrorBit®, MirrorBit® Eclipse™, ORNAND™, ORNAND2™, HD-SIM™, EcoRAM™ and combinations thereof, are trademarks of Spansion LLC in the US and other countries. Other names used are for informational purposes only and may be trademarks of their respective owners.



Стандарт Электрон Связь

Мы молодая и активно развивающаяся компания в области поставок электронных компонентов. Мы поставляем электронные компоненты отечественного и импортного производства напрямую от производителей и с крупнейших складов мира.

Благодаря сотрудничеству с мировыми поставщиками мы осуществляем комплексные и плановые поставки широчайшего спектра электронных компонентов.

Собственная эффективная логистика и склад в обеспечивает надежную поставку продукции в точно указанные сроки по всей России.

Мы осуществляем техническую поддержку нашим клиентам и предпродажную проверку качества продукции. На все поставляемые продукты мы предоставляем гарантию .

Осуществляем поставки продукции под контролем ВП МО РФ на предприятия военно-промышленного комплекса России , а также работаем в рамках 275 ФЗ с открытием отдельных счетов в уполномоченном банке. Система менеджмента качества компании соответствует требованиям ГОСТ ISO 9001.

Минимальные сроки поставки, гибкие цены, неограниченный ассортимент и индивидуальный подход к клиентам являются основой для выстраивания долгосрочного и эффективного сотрудничества с предприятиями радиоэлектронной промышленности, предприятиями ВПК и научно-исследовательскими институтами России.

С нами вы становитесь еще успешнее!

Наши контакты:

Телефон: +7 812 627 14 35

Электронная почта: sales@st-electron.ru

Адрес: 198099, Санкт-Петербург,
Промышленная ул, дом № 19, литера Н,
помещение 100-Н Офис 331