

LOW VOLTAGE VIDEO AMPLIFIER WITH LPF

FEATURES

- Operating Voltage 2.8 to 5.5V
- 2nd Order LPF
- 6dB Amp. , 75Ω Driver
- Power Save Circuit
- Bipolar Technology
- Package Outline SOT-23-6-1

GENERAL DESCRIPTION

The NJM2575 is a Low Voltage Video Amplifier contained LPF circuit. Internal 75Ω driver is easy to connect TV monitor directly.

The NJM2575 features low power and small package, and is suitable for low power design on downsizing of Car camera and CCTV.

APPLICATION

- Car Camera
- Car Navigation
- CCTV

APPLICATION CIRCUIT

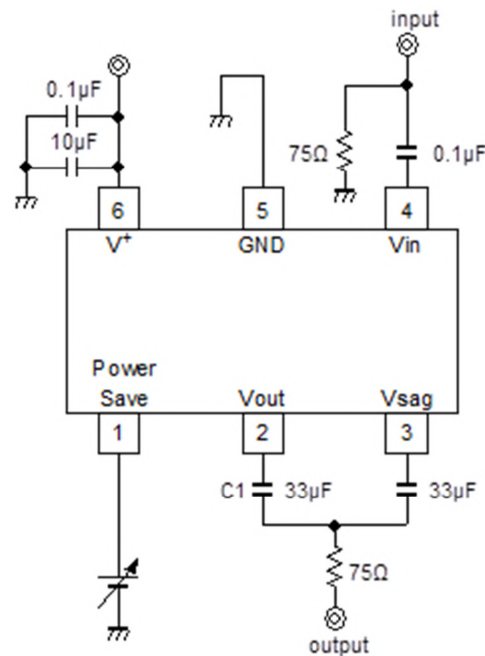

EQUIVALENT CIRCUIT · BLOCK DIAGRAM

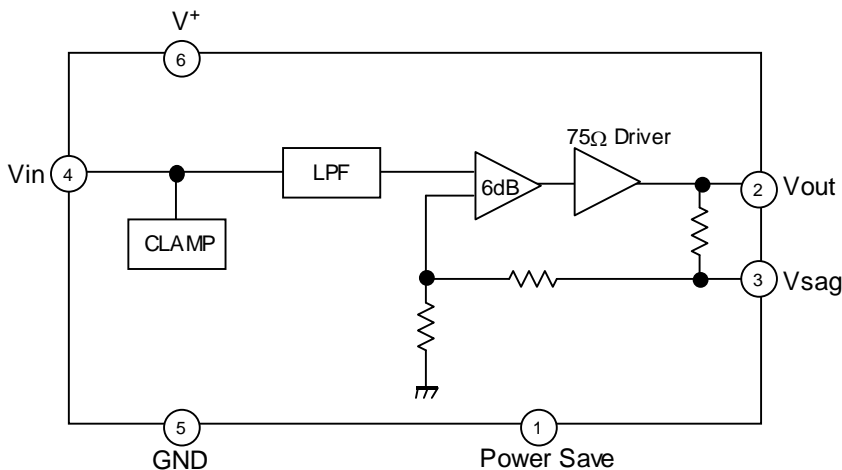

■Voltage Gain Valuation

Voltage Gain	Part No.
6.4dB	NJM2561
6.0dB	NJM2561B
12.4dB	NJM2562
16.5dB	NJM2563
9.0dB	NJM2571A

■Supply Voltage Valuation

Supply Voltage	Part No.
2.6 to 5.5V	NJM2561A

■Output DC - coupling Valuation

Supply Voltage	Part No.
2.8 to 5.5V	NJM2561F1A (Screening product)
2.8 to 5.5V	NJM2561B
4.5 to 5.5V	NJM41031

■Operating Temperature Range Valuation

Operating Temperature Range	Part No.
-40 to 105°C	NJM2561F1-T

■PIN CONFIGURATION

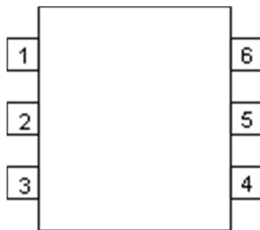

PIN NO.	SYMBOL	DESCRIPTION
1	Power Save	Power Save Terminal
2	Vout	Video Signal Output Terminal
3	Vsag	SAG correction Terminal
4	Vin	Video Signal Input Terminal
5	GND	GND Terminal
6	V+	Power Supply Terminal

■MARK INFORMATION

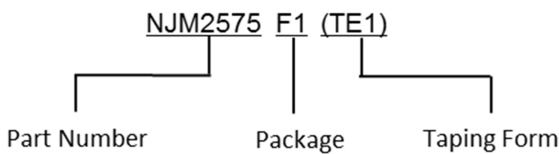

■ORDERING INFORMATION

PART NUMBER	PACKAGE OUTLINE	RoHS	HALOGEN-FREE	TERMINAL FINISH	MARKING	WEIGHT (mg)	MOQ(pcs)
NJM2575F1	SOT-23-6-1	YES	YES	Sn-2Bi	A1	15.0	3,000

■ABSOLUTE MAXIMUM RATINGS

PARAMETER	SYMBOL	RATINGS	UNIT
Supply Voltage	V+	7.0	V
Power Dissipation (Ta=25°C) ⁽⁴⁾	P _D	410 (1)	mW
Operating Temperature Range	T _{opr}	-40 to 85	°C
Storage Temperature Range	T _{stg}	-40 to 125	°C

(1) At on a board of EIA/JEDEC specification. (114.3 x 76.2 x 1.6mm 2 layers, FR-4)

■RECOMMENDED OPERATING CONDITIONS

PARAMETER	SYMBOL	RATINGS	UNIT
Supply Voltage	V+	2.8 to 5.5	V

■POWER DISSIPATION vs. AMBIENT TEMPERATURE

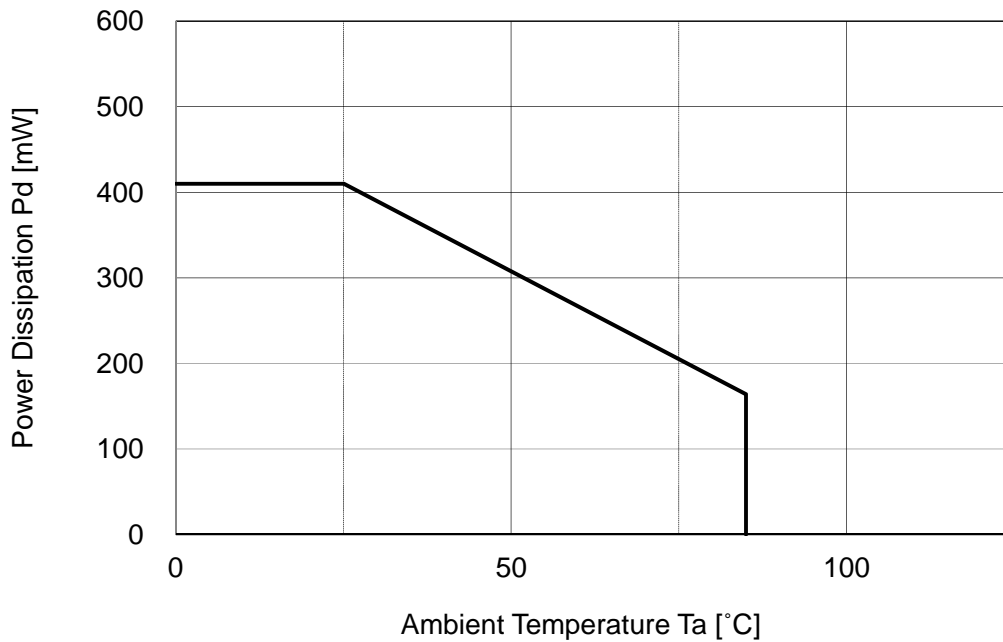

■ ELECTRICAL CHARACTERISTICS ($V^+=3.0V, R_L=150\Omega, T_a=25^\circ C$)

PARAMETER	SYMBOL	TEST CONDITION	MIN.	TYP.	MAX.	UNIT
Operating Current	I_{CC}	No Signal	-	7.0	10.0	mA
Operating Current at Power Save	I_{save}	Power Save Mode	-	60	90	μA
Maximum Output Voltage Swing	V_{om}	$f=100kHz, THD=1\%$	2.2	2.4	-	Vp-p
Voltage Gain	G_v	$V_{in}=100kHz, 1.0Vp-p,$ Input Sine Signal	6.1	6.5	6.9	dB
Low Pass Filter Characteristic	$G_{fy4.5M}$	$V_{in}=4.5MHz/100kHz, 1.0Vp-p$	-0.5	0	0.5	dB
	G_{fy19M}	$V_{in}=8MHz/100kHz, 1.0Vp-p$	-	-2.0	-	
	G_{fy16M}	$V_{in}=16MHz/100kHz, 1.0Vp-p$	-	-12.0	-	
Differential Gain	DG	$V_{in}=1.0Vp-p, 10step$ Video Signal	-	0.2	-	%
Differential Phase	DP	$V_{in}=1.0Vp-p, 10step$ Video Signal	-	0.2	-	deg
S/N Ratio	SN_v	$V_{in}=1.0Vp-p, R_L=75\Omega$ 100% White Video Signal, 100kHz to 6MHz	-	60	-	dB
2nd. Distortion	H_v	$V_{in}=1.0Vp-p, 3.58MHz,$ Sine Signal, $R_L=75\Omega$	-	-40	-	dB
SW Change Voltage High Level	V_{thPH}	Active	1.8	-	V^+	V
SW Change Voltage Low Level	V_{thPL}	Non-active	0	-	0.3	

■ CONTROL TERMINAL

PARAMETER	STATUS	NOTE
Power Save	H	Power Save: OFF (Active)
	L	Power Save: ON (Mute)
	OPEN	Power Save: ON (Mute)

TEST CIRCUIT

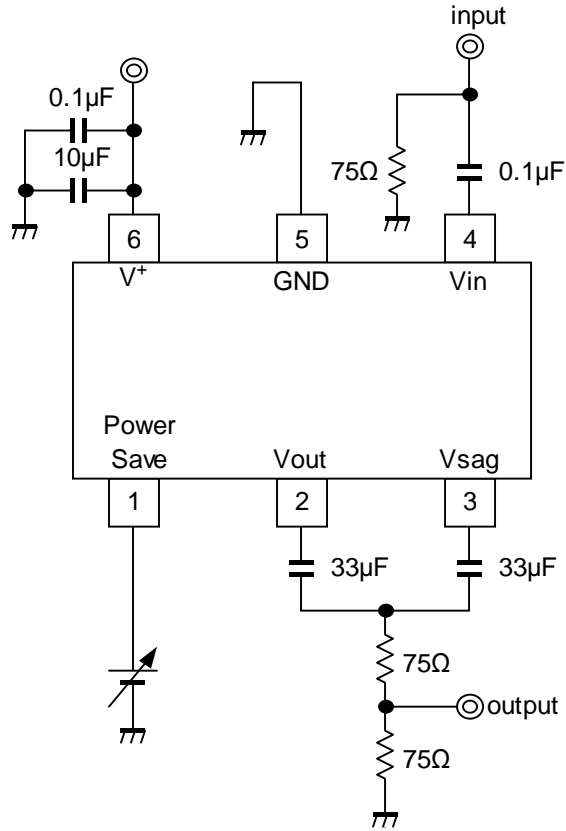

APPLICATION CIRCUIT

(1) Standard circuit

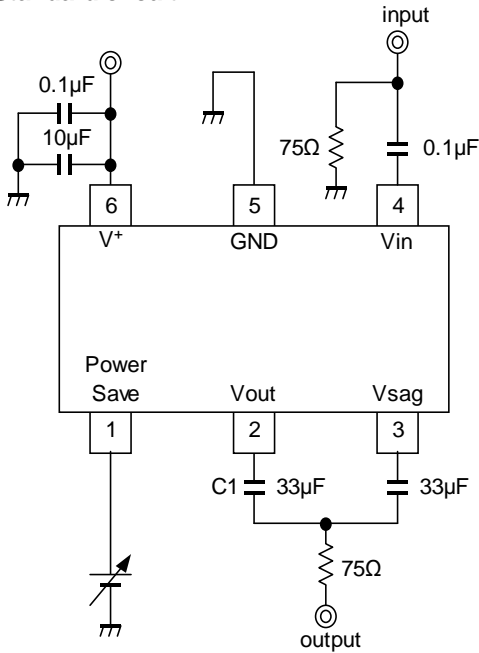

(2) SAG correction unused circuit

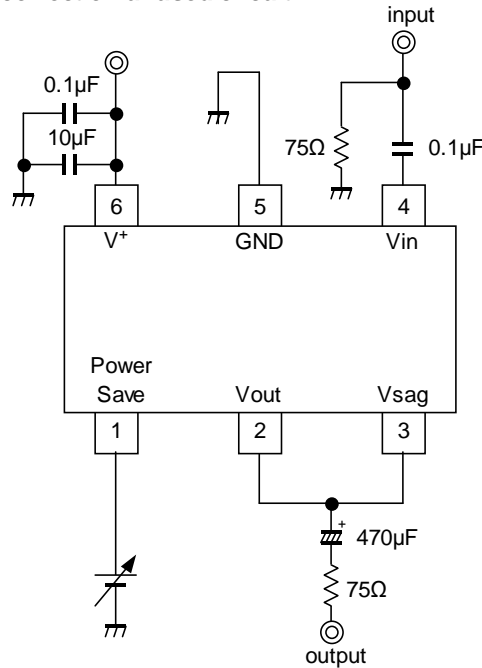

(3) Two-line driving circuit

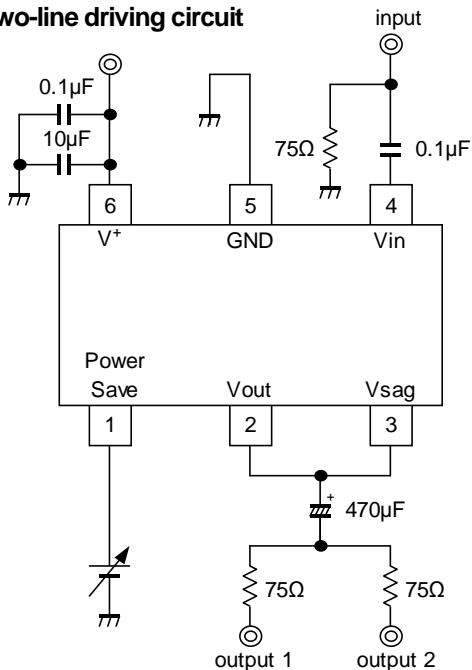

(1) Standard circuit

This circuit is for a portable equipment of small mounting space. The SAG correction reduces output coupling capacitor values. However, this circuit may cause to SAG deterioration, and lose synchronization by luminance fluctuation. Adjust the C1 value, checking the waveform containing a lot of low frequency components like a bounce waveform (Worst condition waveform of SAG). Change the capacitor of C1 into a large value to improve SAG.

(2) SAG correction unused circuit

We recommend this circuit when there is no space limitation. Connect the coupling capacitor after connecting the Vout pin and Vsag pin. The recommended value is 470µF or more.

(3) Two-line driving circuit

This circuit drives two-line of 150Ω. However, it may cause to lose synchronization by an input signal of large APL change (100% white signals more than 1Vp-p). Confirm the large APL change waveform (100% white signals more than 1Vp-p) and evaluate sufficiently.

■TERMINAL DESCRIPTION

PIN.No.	SYMBOL	EQUIVALENT CIRCUIT	DC VOLTAGE
1	Power Save		-
2	Vout		0.26V
3	Vsag		-
4.	Vin		1.1V
5	GND	-	-
6	V+	-	-

APPLICATION

•SAG correction circuit

SAG correction circuit is a circuit to correct for low-frequency attenuation by high-pass filter consisting of the output coupling capacitance and load resistance. Low-frequency attenuation raises the sag in the vertical period of the video signal.

Capacitor for Vsag (C_{sag}) is connected to the negative feedback of the amplifier. This C_{sag} increase the low frequency gain to correct for the attenuation of low frequency gain.

Example SAG collection circuit

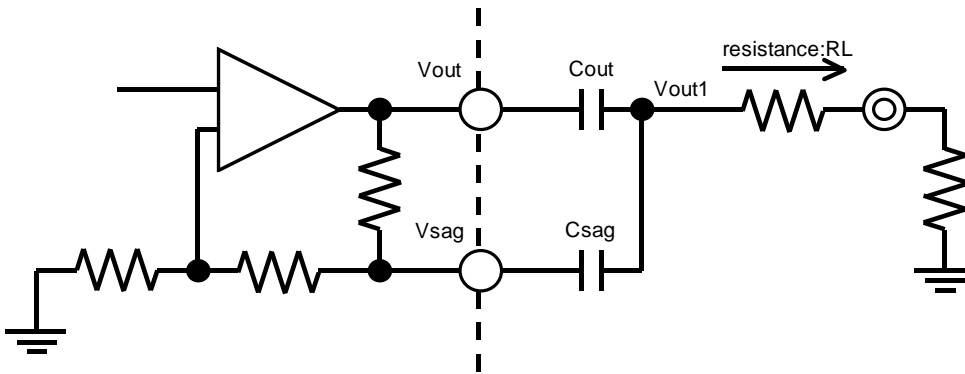

Example of not using sag compensation circuit

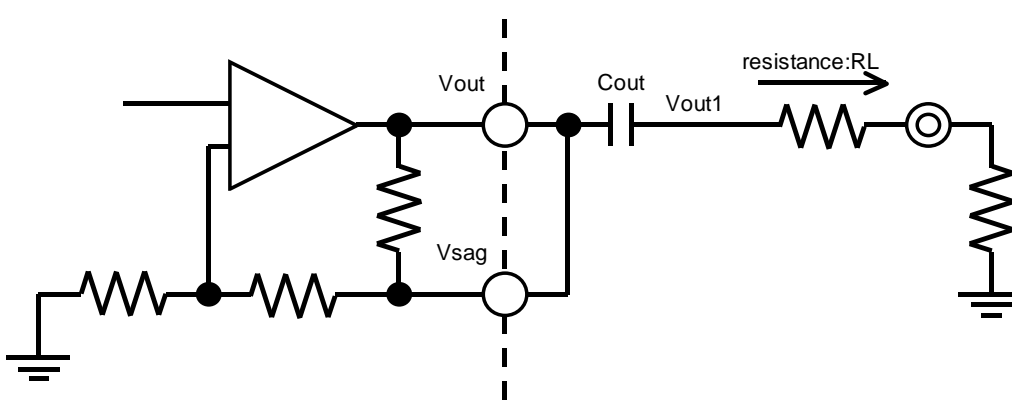

Waveform of Vout terminal and Vout1 terminal

using SAG correction circuit
Waveform of Vout

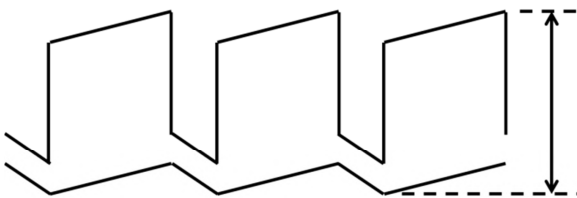

Waveform of Vout1

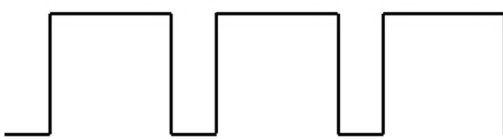

1Vertical period

not using SAG correction circuit
Waveform of Vout

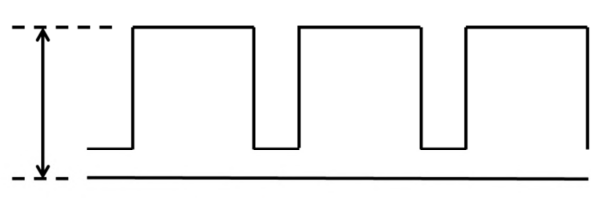

Waveform of Vout1

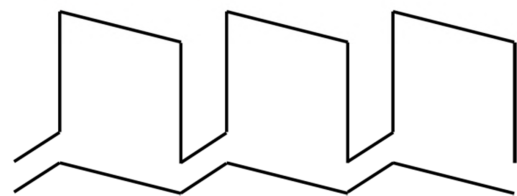

1Vertical period

SAG correction circuit generates a low frequency component signal amplified to Vout terminal. Changes of the luminance signal will be low-frequency components, if you want to output a large signal luminance changes. Therefore, generate correction signal of change of a luminance signal to Vout pin. At this time, signal is over the dynamic range of Vout pin. This may cause a lack of sync signal, and waveform distortion.

Please see diagram below (green waveform), if you want to output large changes of a signal luminance, such as 100% white video signal and black signal. Thus, output signal exceed dynamic range of Vout pin and may be the signal lack.

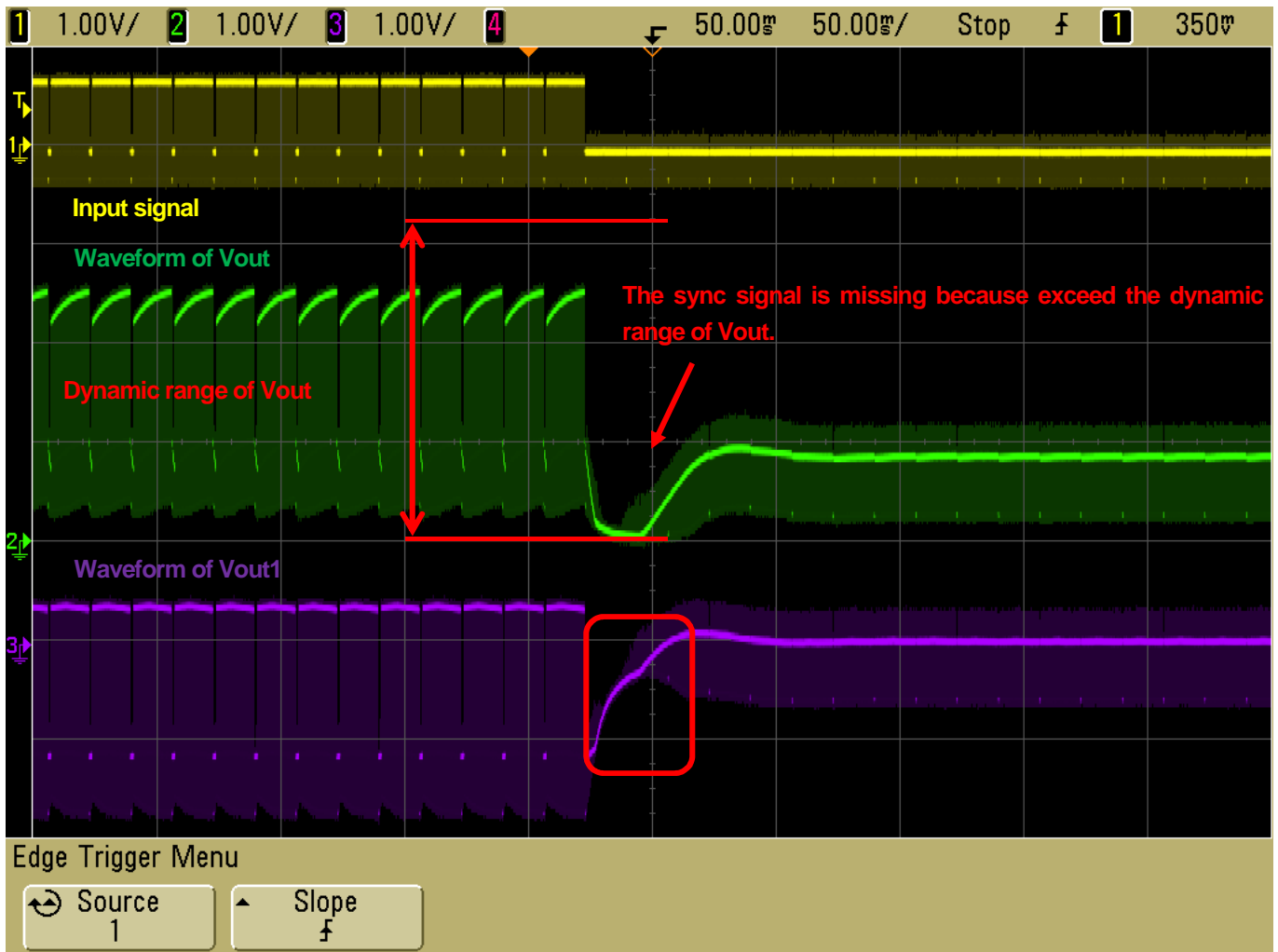

< Countermeasure for waveform distortion >

1. Please using small value the Sag compensation capacitor (VSAG).
It can ensure the dynamic range by using small value the capacitor (VSAG). It because of low-frequency variation of Vout pin is smaller. However, the output (VOUT) must be use large capacitor for this reason sag characteristics become exacerbated.
2. Please do not use the sag correction circuit.
Signal can output within dynamic range for reason it does not change the DC level of the output terminal.
However, the output (VOUT) must be use large capacitor for this reason sag characteristics become exacerbated.

< Dual drive at using SAG correction circuit >

Using sag correction circuit at dual drive circuit is below. Dual drives are less load resistance. Thus, the cut-off frequency of HPF that is composed of the output capacitor and load resistance will be small. Therefore, the sag characteristics deteriorate. Please size up to the output capacitor (Vout) for not to deteriorate the sag characteristics.

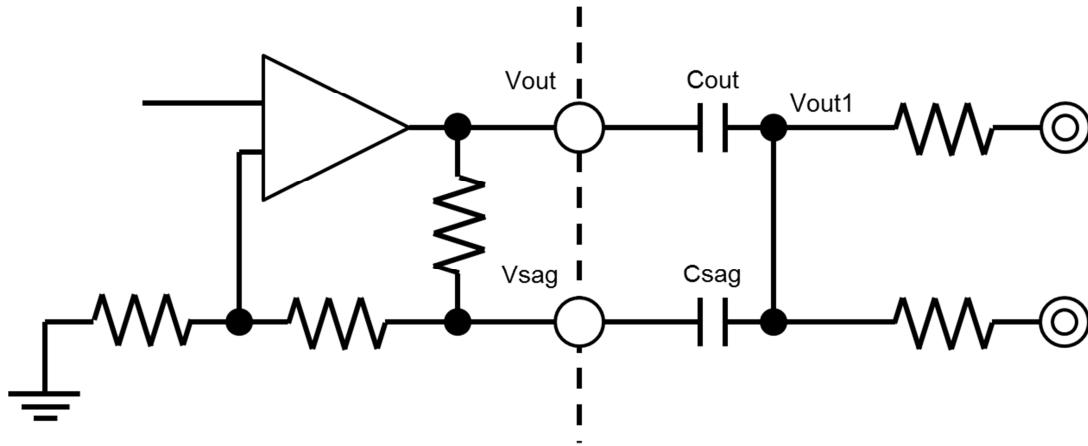

< Dual drive at not using SAG correction circuit >

We recommended two-example dual drive circuit with not use sag correction circuit. Please change the configuration to be used according to the situation. Please configure to meet the following conditions. Then you can adjust the characteristics of each configuration.

$$C_{out} = C_{out1} + C_{out2}$$

$$C_{out1} = C_{out2}$$

(A) In case of using one output capacitor

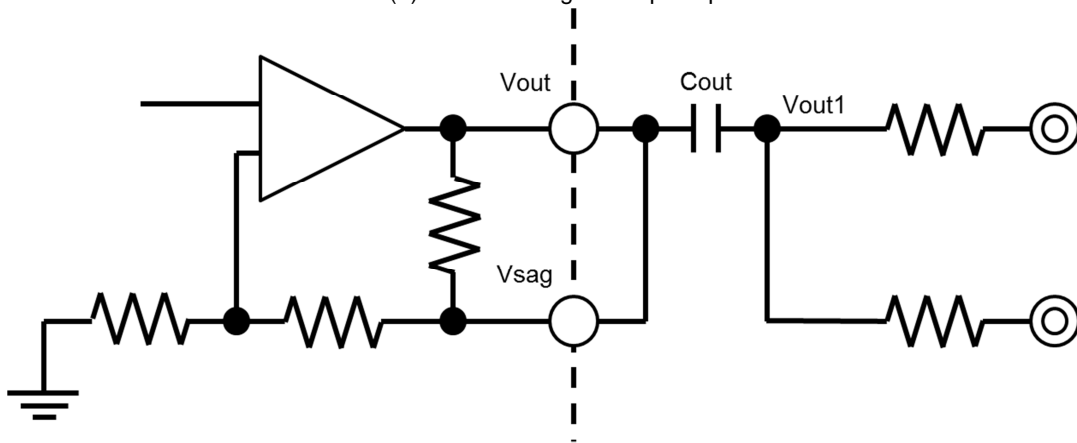

(B) In case of using two output capacitors

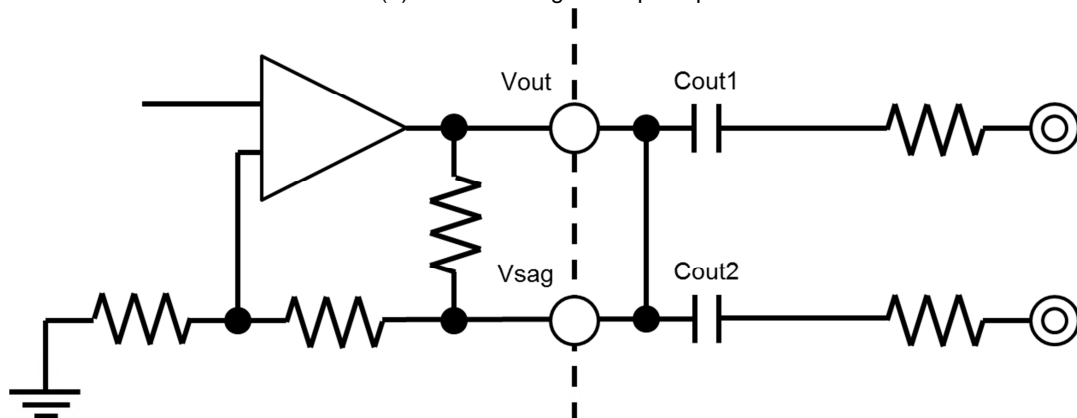

< Using SAG correction circuit >

Input signal: bounce signal (IRE0%, IRE100%, 30Hz), resistance=150Ω, Waveform: yellow: input signal, green: Vout signal, purple: Vout1signal

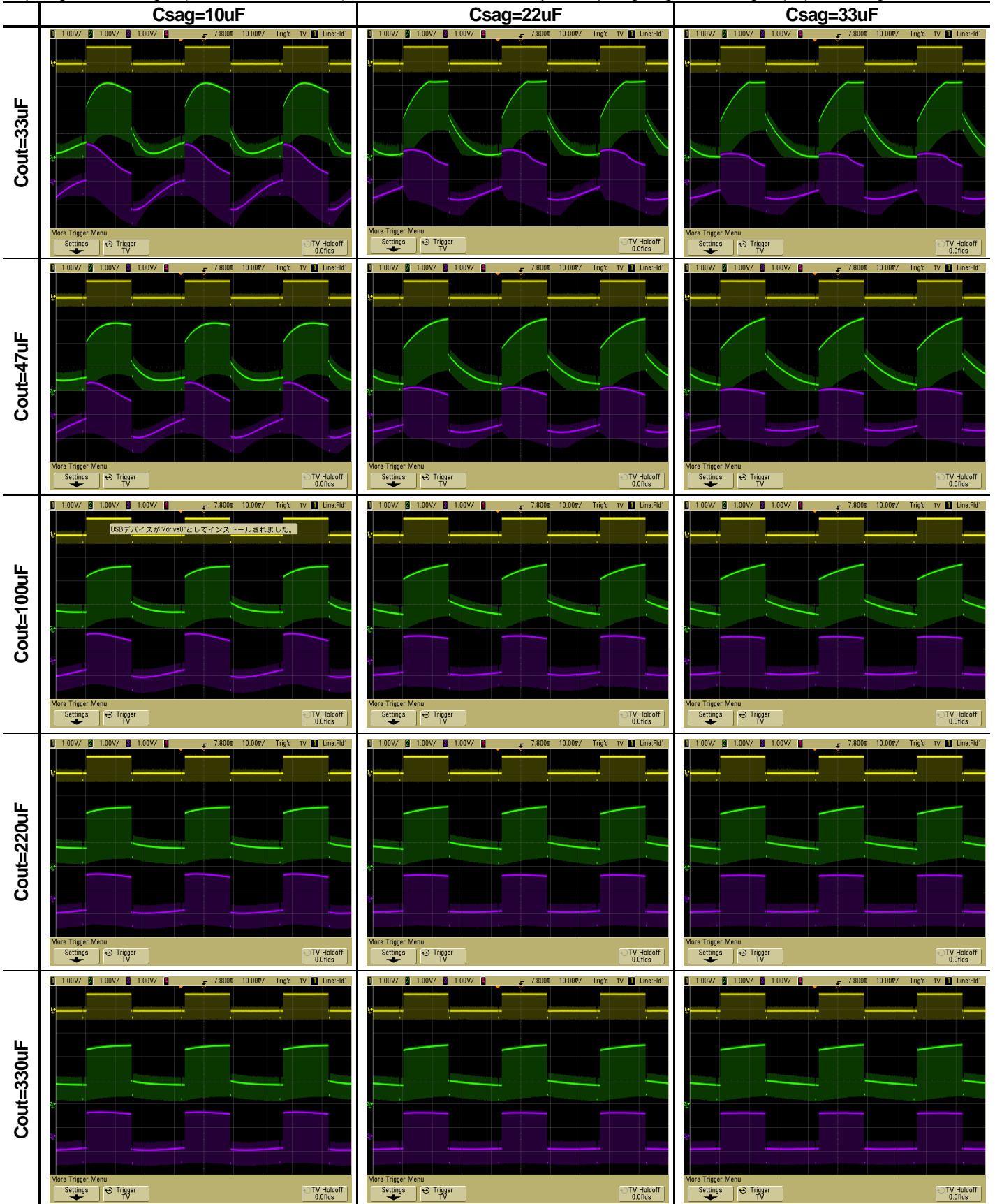

Input signal: bounce signal (IRE0%, IRE100%, 30Hz), resistance=75Ω, Waveform: yellow: input signal, green: Vout signal, purple: Vout1 signal

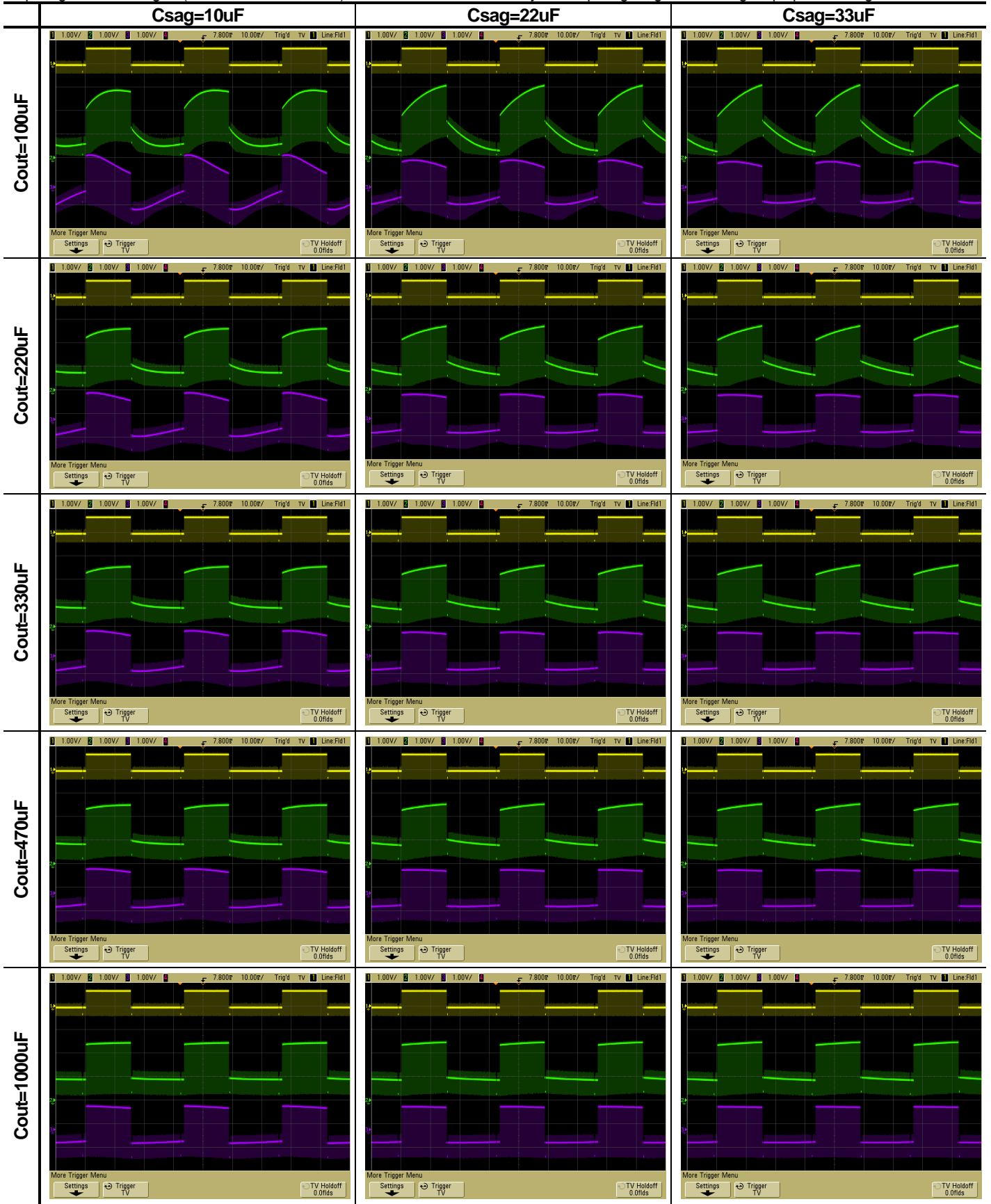

< Not using SAG correction circuit >

Input signal: bounce signal (IRE0%, IRE100%, 30Hz), resistance=150Ω, Waveform: yellow: input signal, green: Vout signal, purple: Vout1 signal

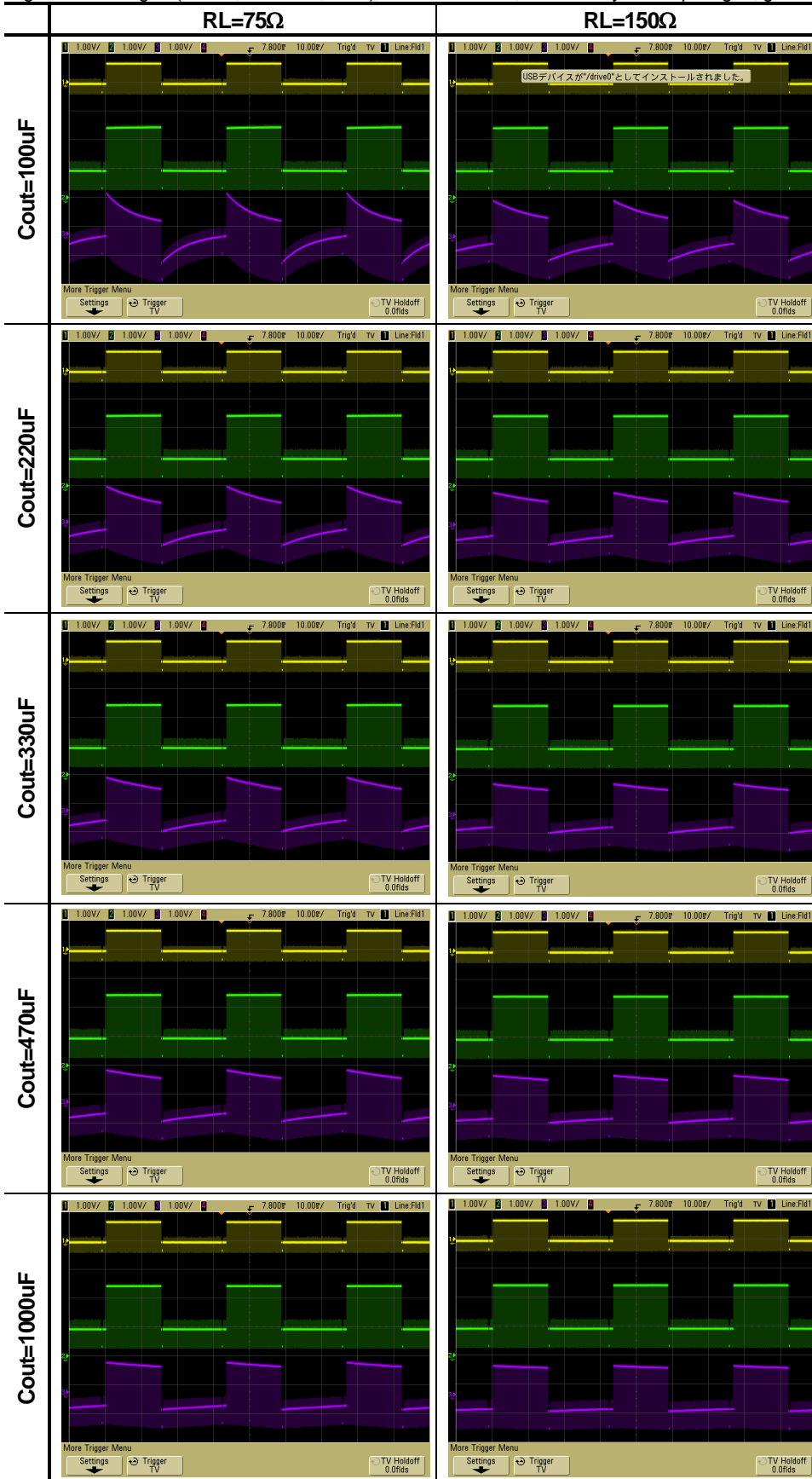

< Using SAG correction circuit >

Input signal: Black to White100%, resistance150Ω, Waveform: yellow: input signal, green: Vout signal, purple: Vout1signal

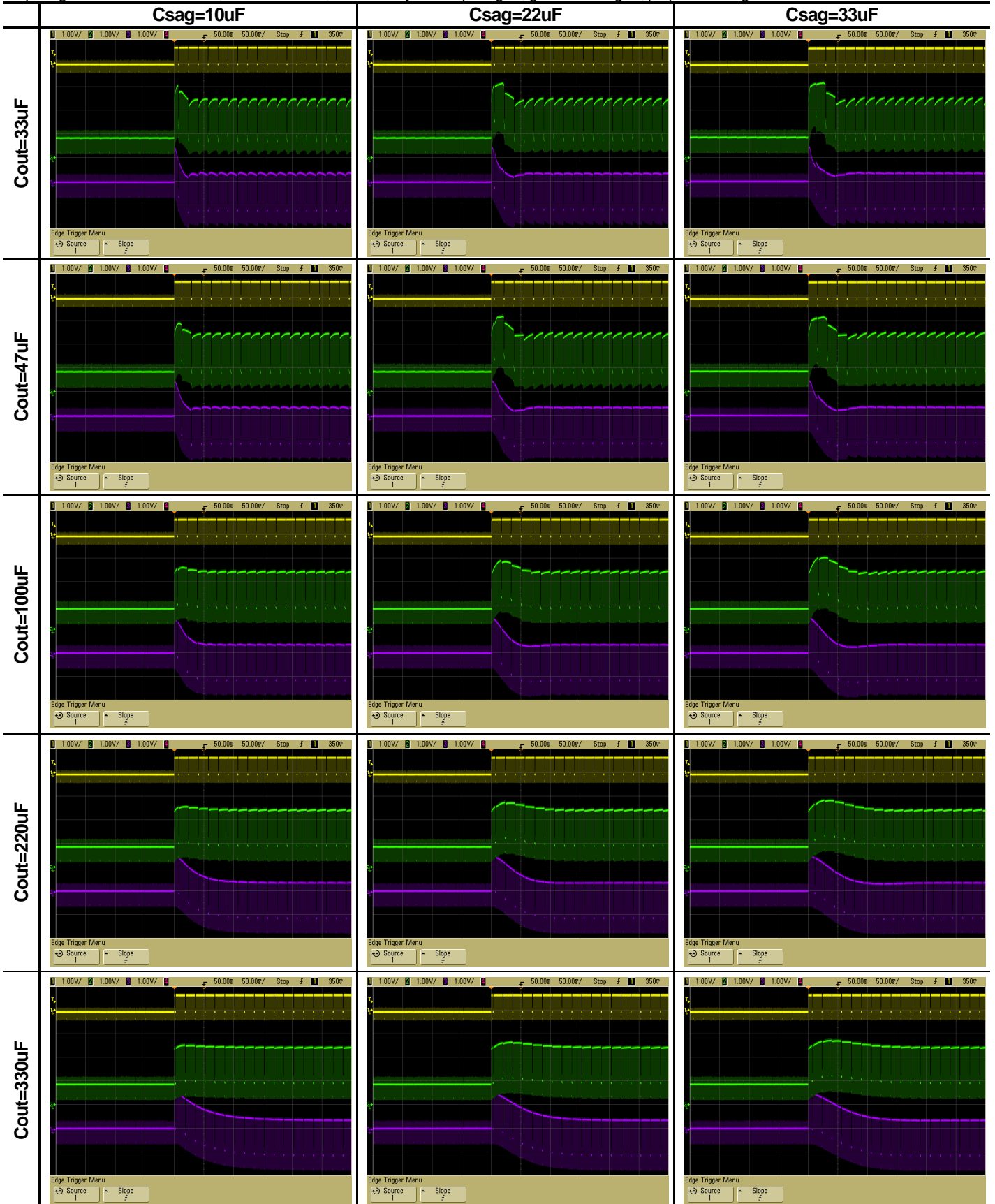

Input signal: White 100% to Black, resistance 150Ω, Waveform: yellow: input signal, green: Vout signal, purple: Vout1 signal

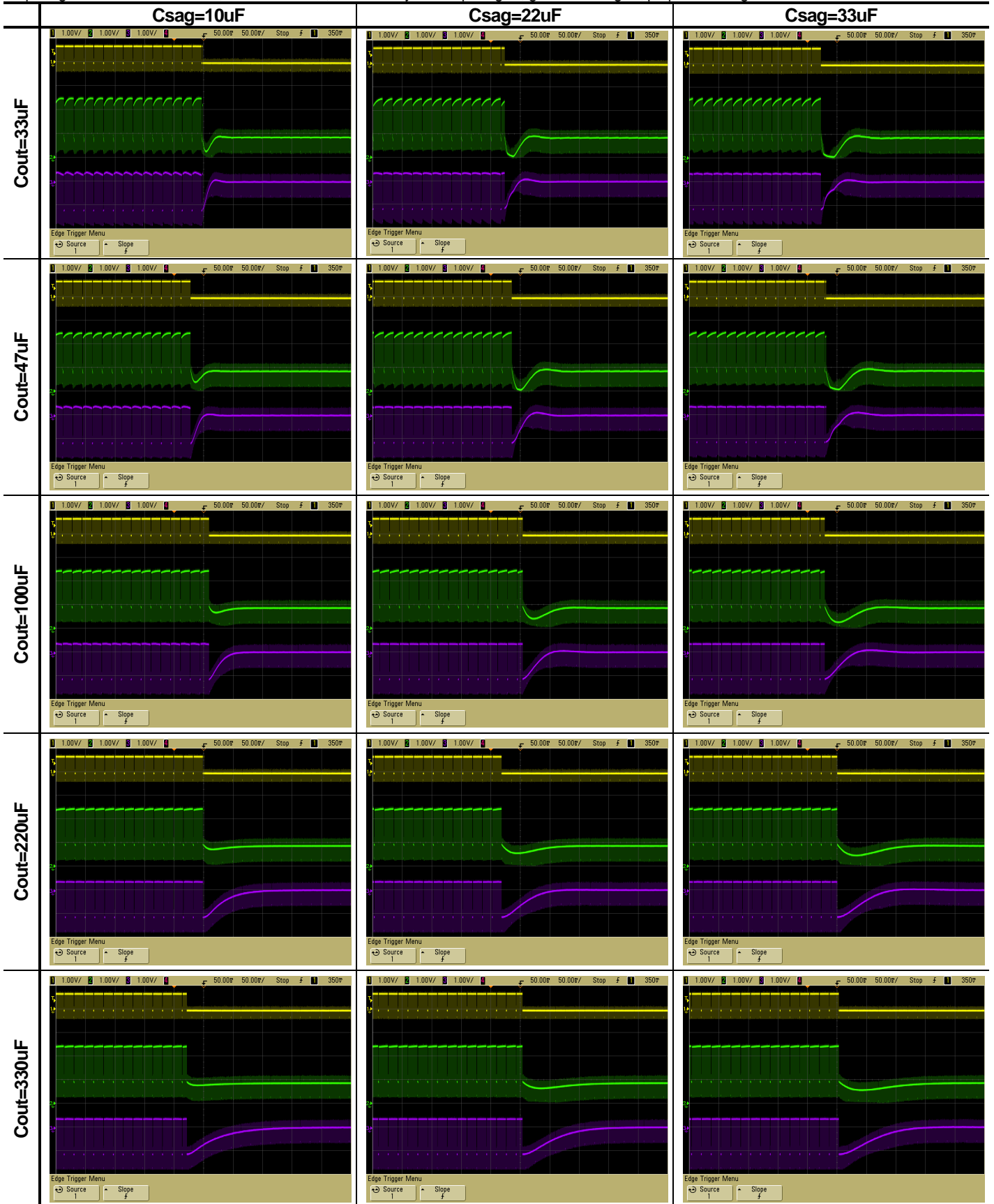

< Using SAG correction circuit >

Input signal: Black to White100%, resistance=75Ω, Waveform: yellow: input signal, green: Vout signal, purple: Vout1signal

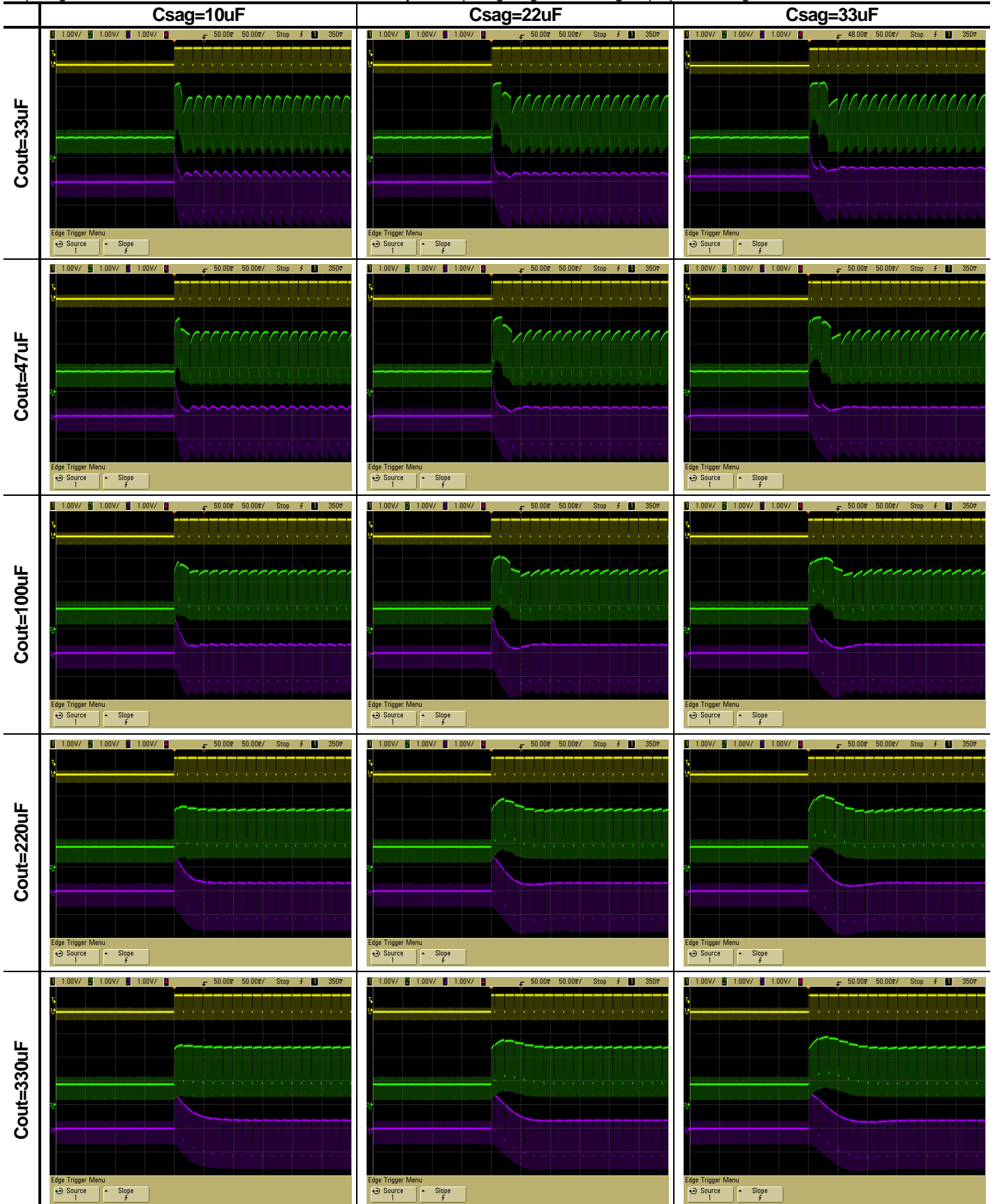

Input signal: White 100% to Black, resistance=75Ω, Waveform: yellow: input signal, green: Vout signal, purple: Vout1 signal

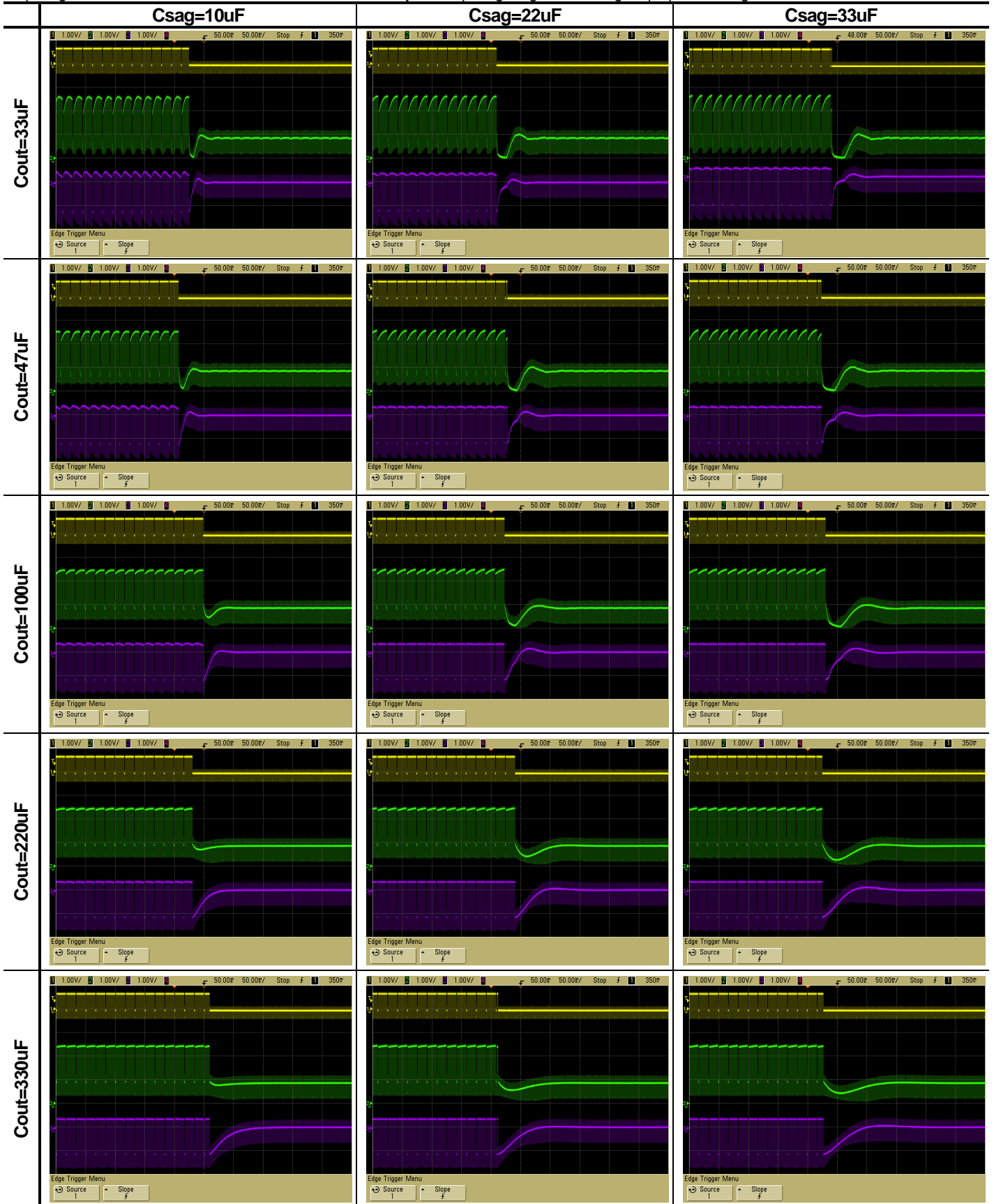

◆Clamp circuit

1. Operation of Sync-tip-clamp

Input circuit will be explained. Sync-tip clamp circuit (below the clamp circuit) operates to keep a sync tip of the minimum potential of the video signal. Clamp circuit is a circuit of the capacitor charging and discharging of the external input C_{in} . It is charged to the capacitor to the external input C_{in} at sync tip of the video signal. Therefore, the potential of the sync tip is fixed.

And it is discharged charge by capacitor C_{in} at period other than the video signal sync tip. This is due to a small discharge current to the IC.

In this way, this clamp circuit is fixed sync tip of video signal to a constant potential from charging of C_{in} and discharging of C_{in} at every one horizontal period of the video signal.

The minute current be discharged an electrical charge from the input capacitor at the period other than the sync tip of video signals. Decrease of voltage on discharge is dependent on the size of the input capacitor C_{in} .

If you decrease the value of the input capacitor, will cause distortion, called the H sag. Therefore, the input capacitor recommend on more than 0.1 μ F.

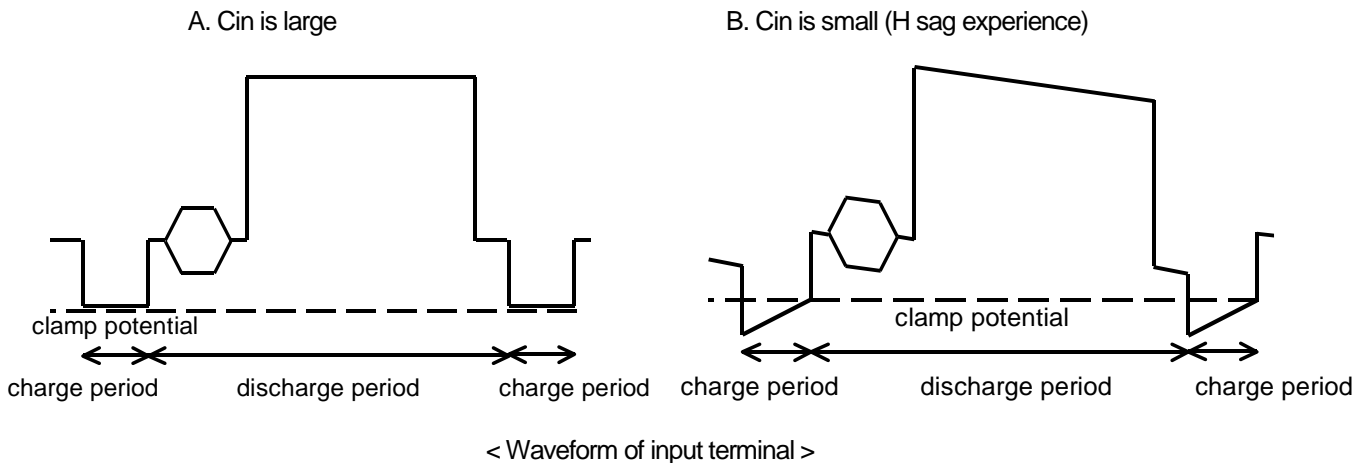
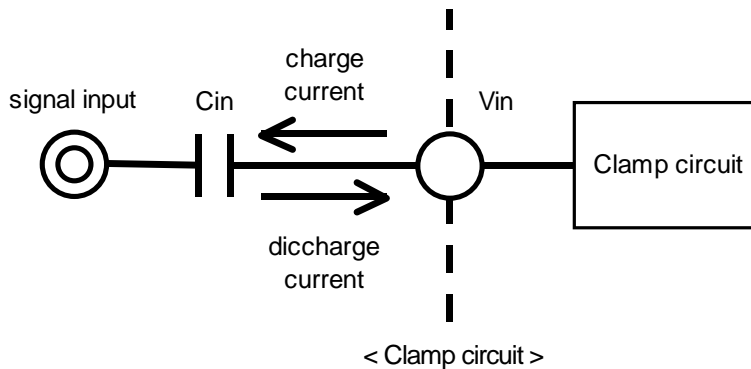

2. Input impedance

The input impedance of the clamp circuit is different at the capacitor discharge period and the charge period.

The input impedance of the charging period is a few $k\Omega$. On the other hand, the input impedance of the discharge period is several $M\Omega$. Because is a small discharge-current through to the IC.

Thus the input impedance will vary depending on the operating state of the clamp circuit.

3. Impedance of signal source

Source impedance to the input terminal, please lower than 200 Ω . A high source impedance, the signal may be distorted. If so, please to connect a buffer for impedance conversion.

■ TYPICAL CHARACTERISTICS

Frequency Characteristic

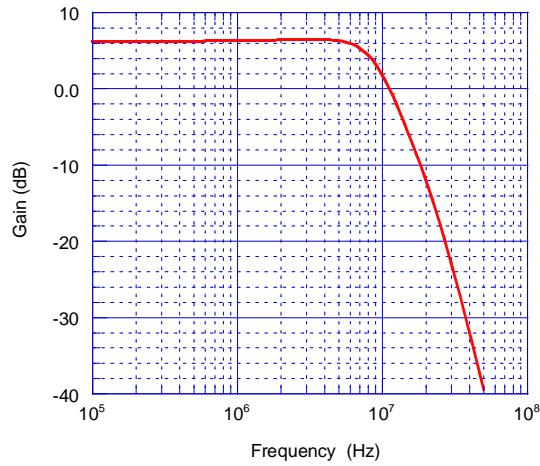

Operating Current vs. Supply Voltage

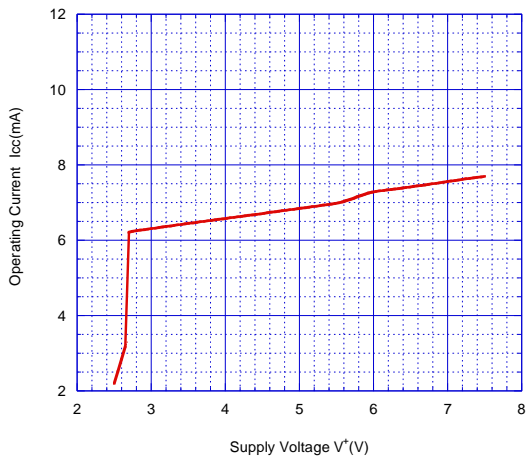

Operating Current at Standby State vs. Supply Voltage

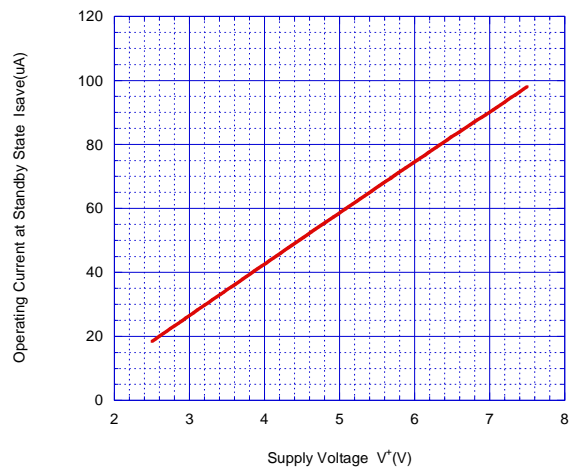

Maximum Output Voltage Swing vs. Supply Voltage

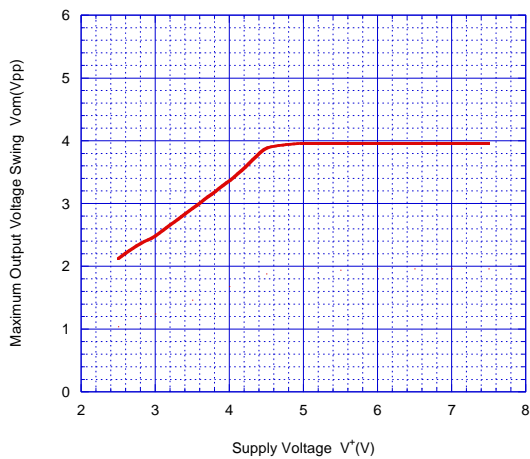

Voltage Gain vs. Supply Voltage

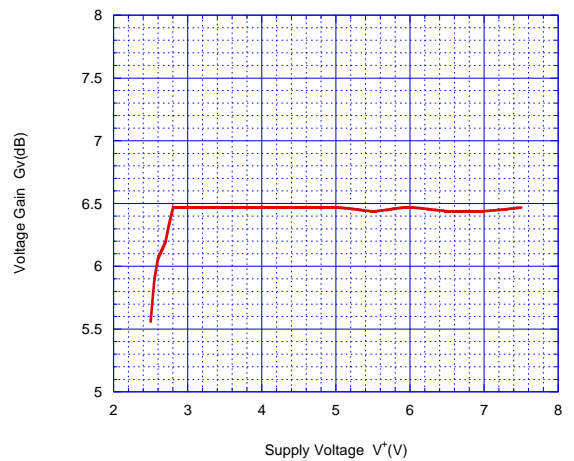

■ TYPICAL CHARACTERISTICS

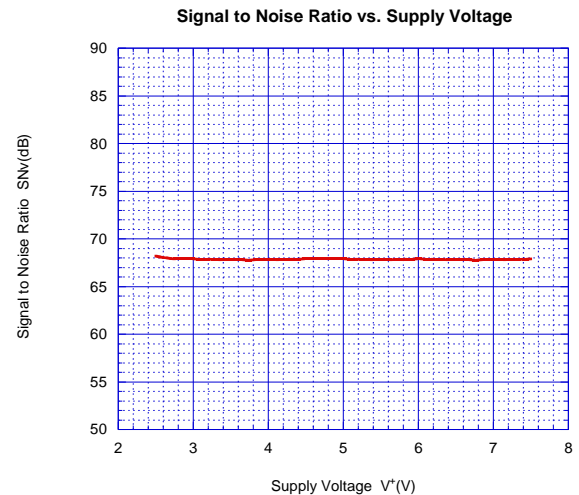
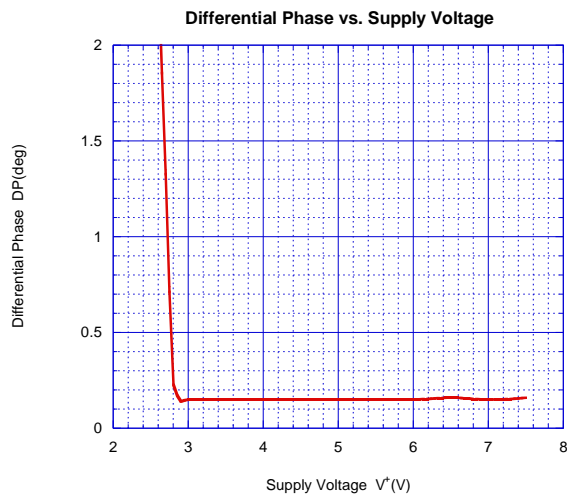
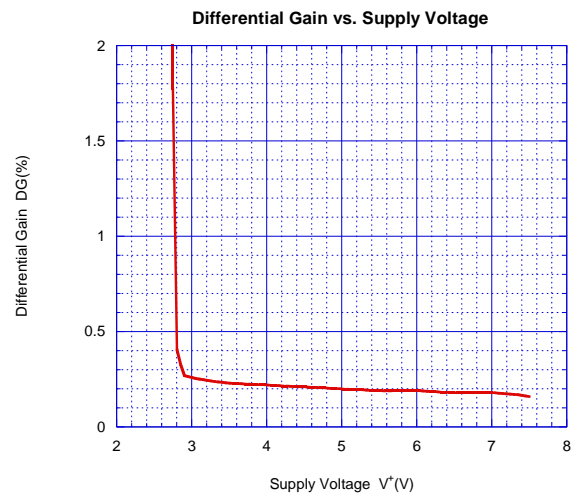
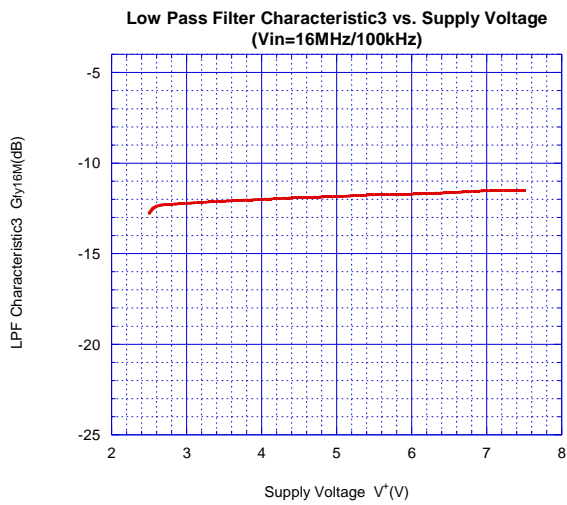
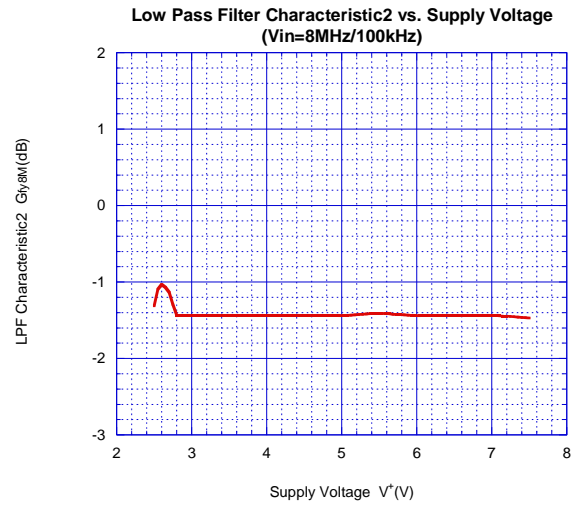
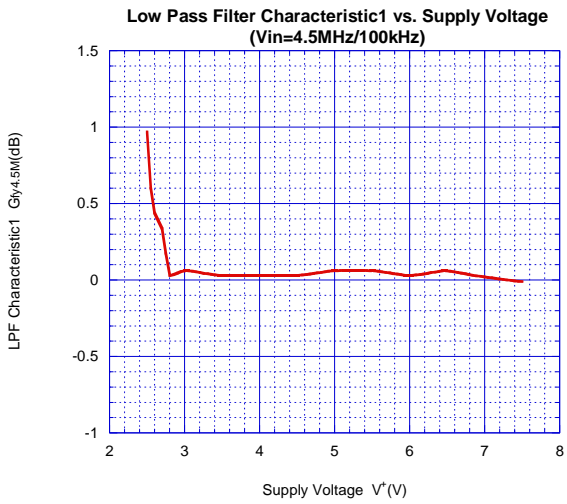

■ TYPICAL CHARACTERISTICS

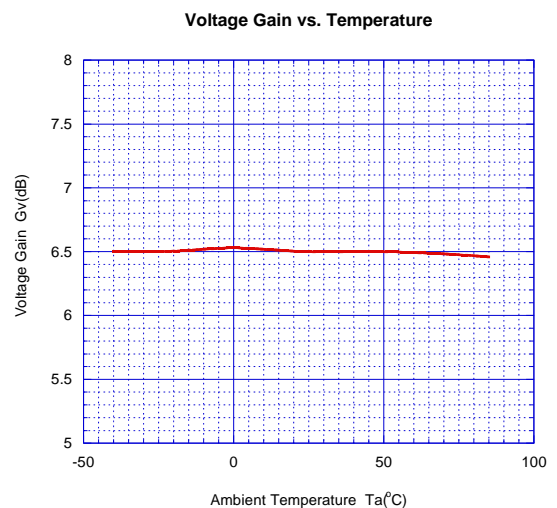
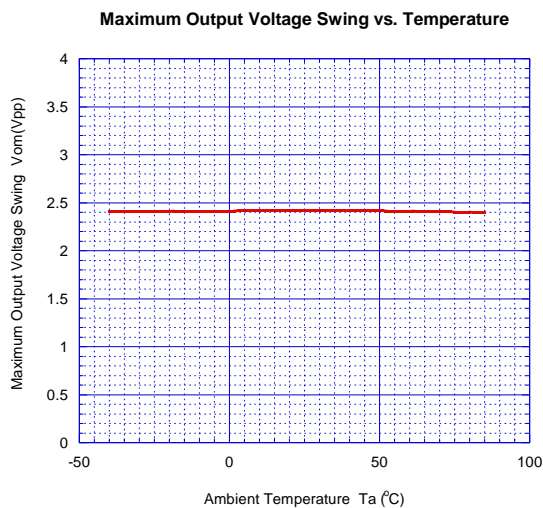
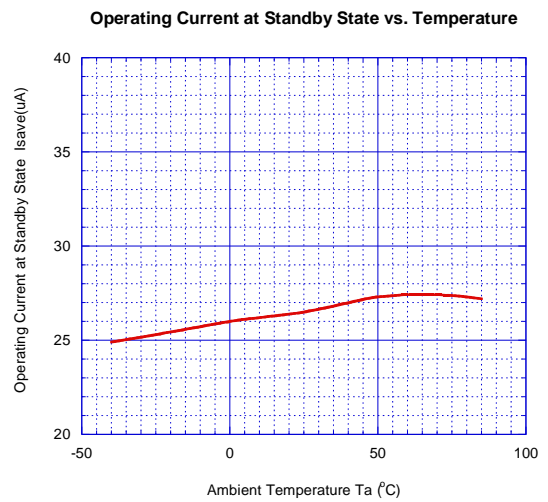
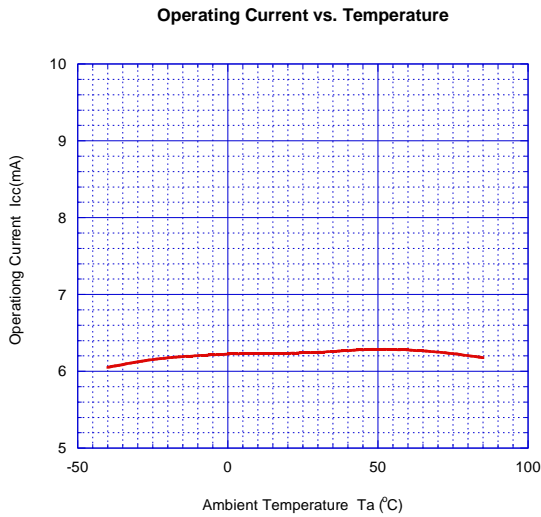
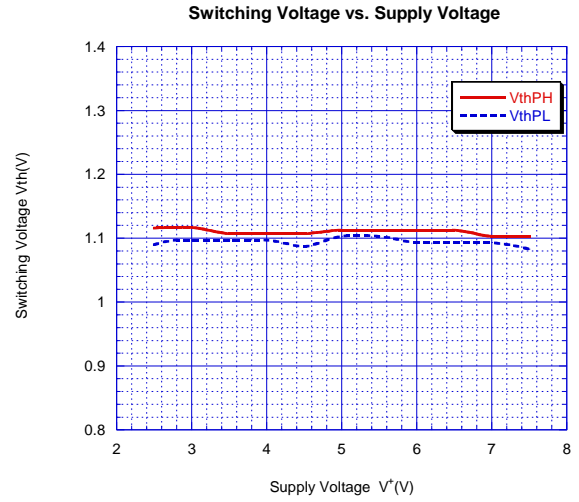
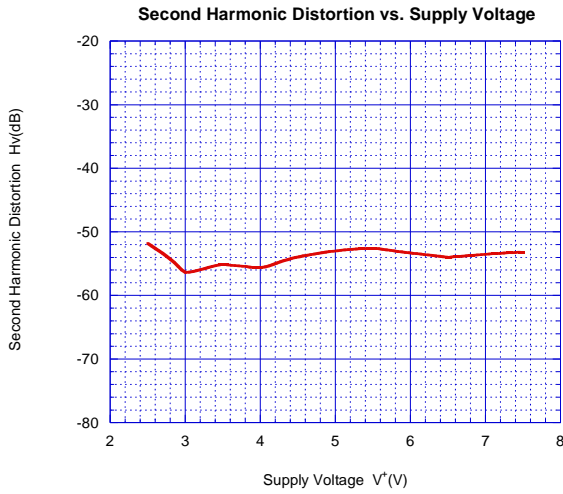

■ TYPICAL CHARACTERISTICS

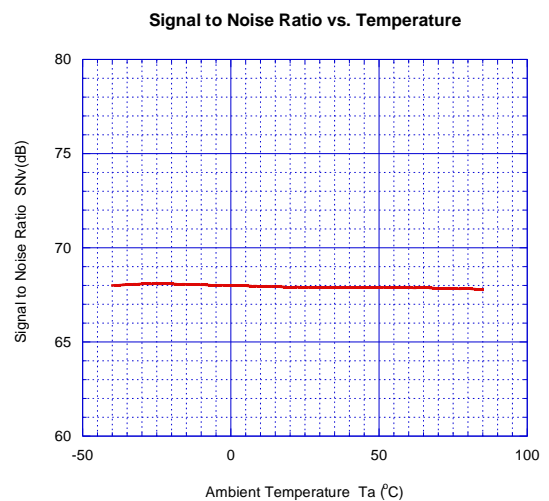
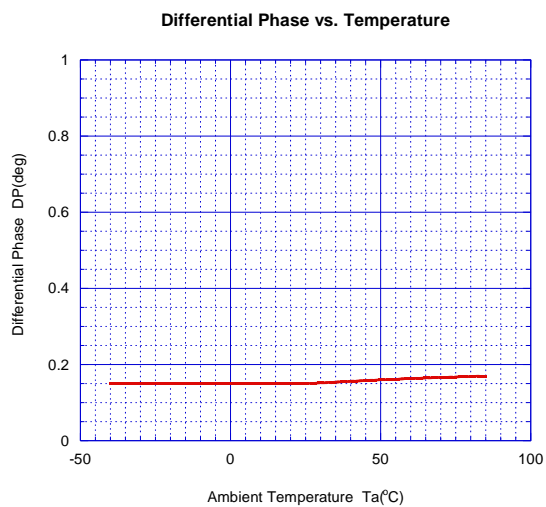
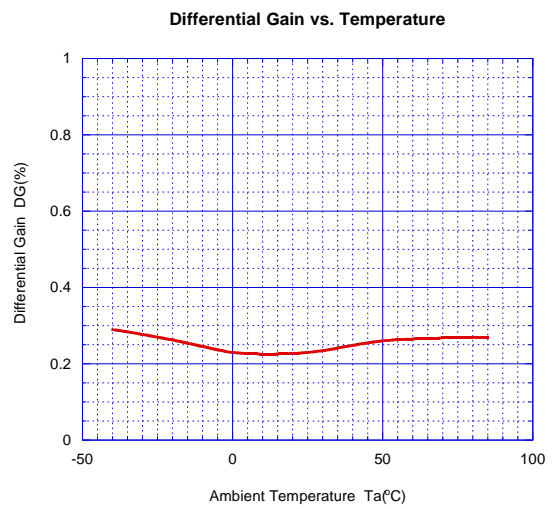
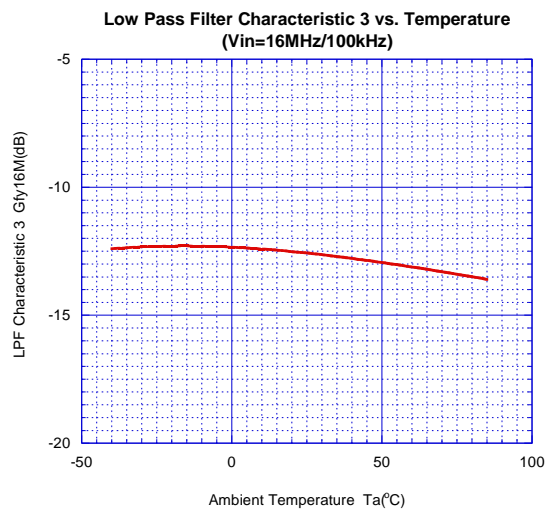
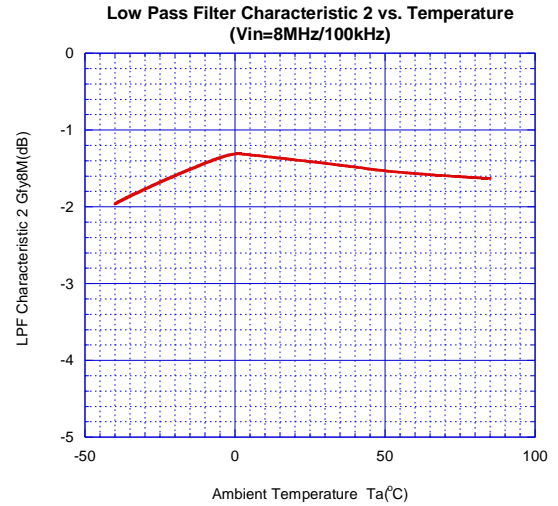
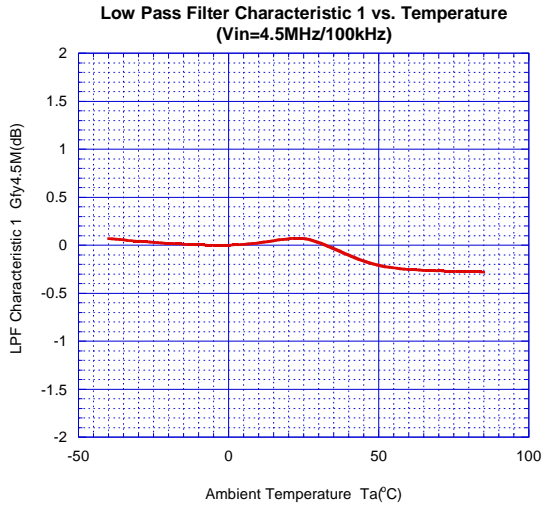

■ TYPICAL CHARACTERISTICS

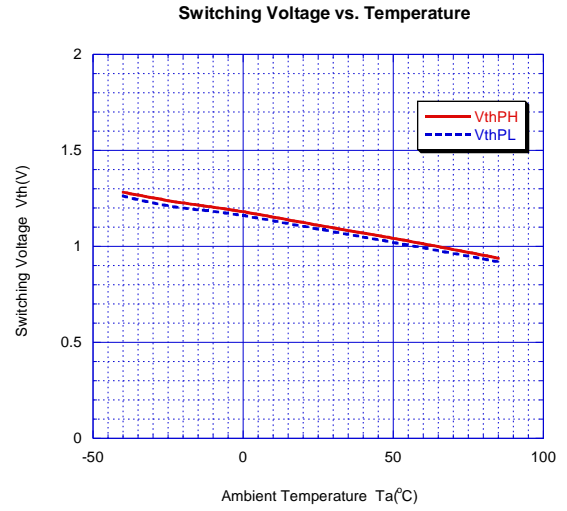
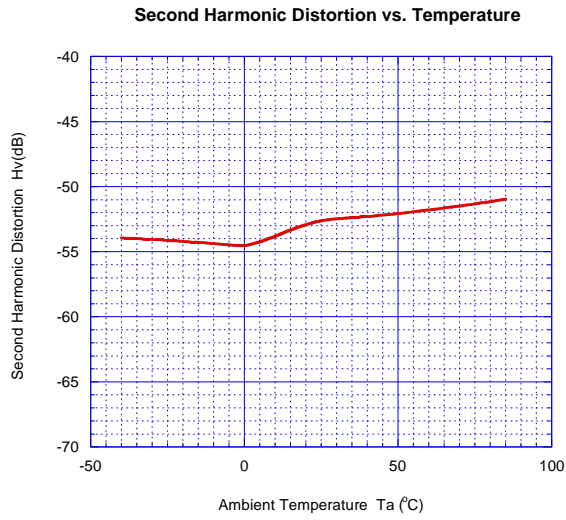

■PACKAGE OUTLINE

SOT-23-6-1(MTP6-1)

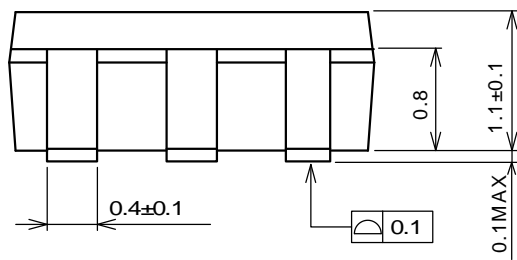
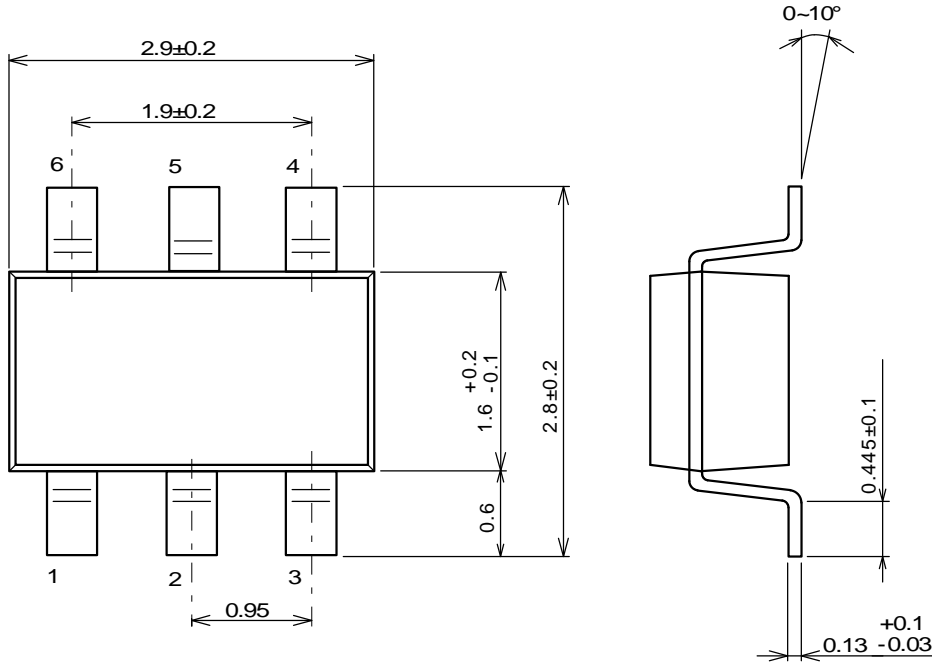

■SOLDER FOOT PRINT

PKG	b	l	c	e1	e
SOT-23-6-1	0.70	1.00	1.90	2.40	0.95

UNIT : mm

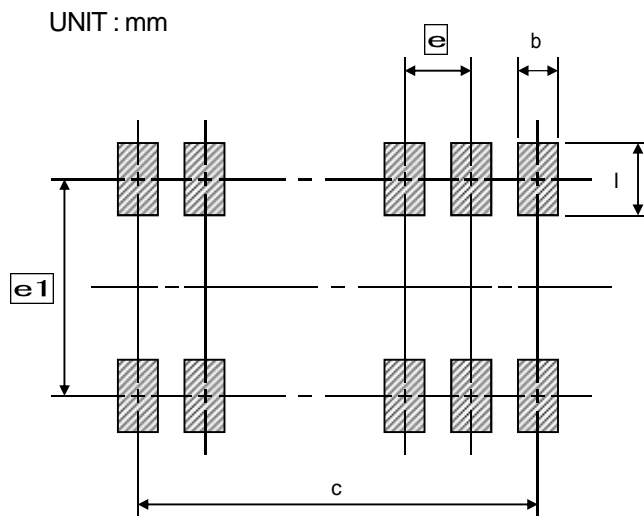

Note : These solder foot print dimensions are just examples.
When designing PCB, please estimate the pattern carefully.

PACKING SPECIFICATION

General Description

NJRC delivers ICs in 4 methods, plastic tube container, two kinds of Taping, tray and vinyl bag packing.
 Except adhesive tape treated anti electrostatic and contain carbon are using as the ESD (Electrostatic Discharge Damage) protection.

SOT-23(MTP) Emboss Taping (TE1)

Symbol	SOT-23-6-1	Remark
A	3.3±0.1	Bottom size
B	3.2±0.1	Bottom size
D ₀	1.55	
D ₁	1.05	
E	1.75±0.1	
F	3.5±0.05	
P ₀	4.0±0.1	
P ₁	4.0±0.1	
P ₂	2.0±0.05	
T	0.25±0.05	
T ₂	1.57	
W	8.0±0.3	
W ₁	5.5	Thickness 0.1MAX

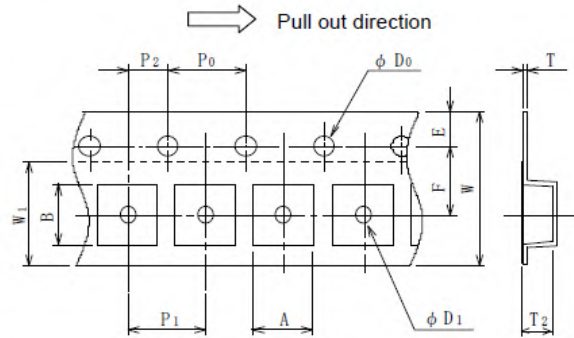

Symbol	SOT-23-6-1
A	Ø180±1
B	Ø 60±1
C	Ø 13±0.2
D	Ø 21±0.8
E	2±0.5
W	9±0.5
W ₁	1.2±0.2
Contents	3,000pcs

Unit : mm

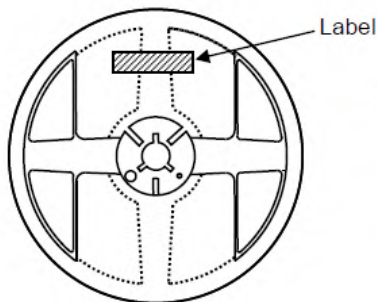
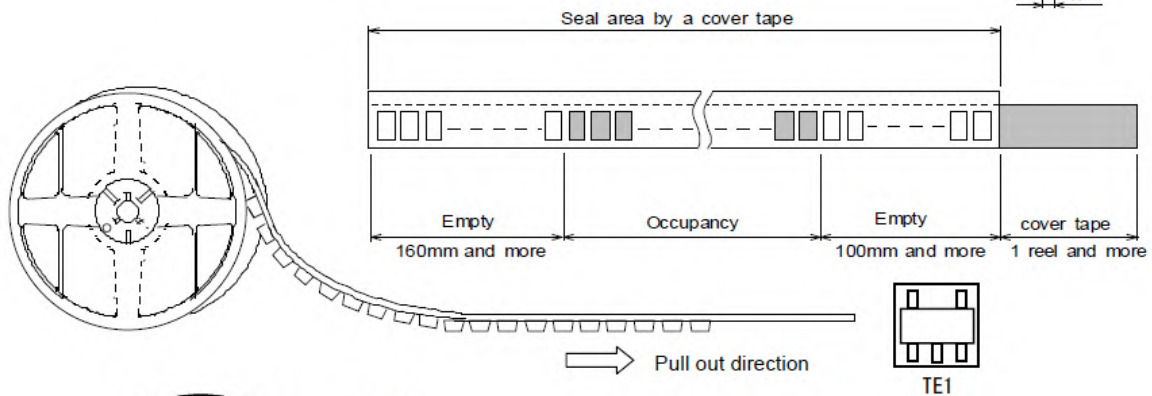
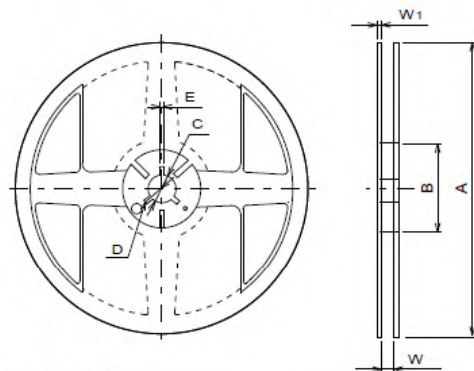

Put in the outer box



Label

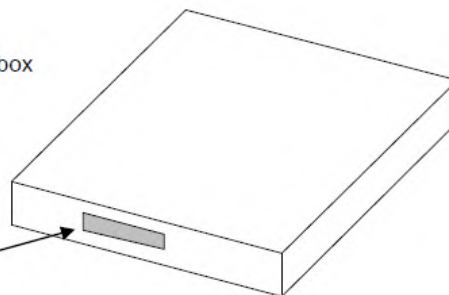

RECOMMENDED MOUNTING METHOD

* Recommended reflow soldering procedure

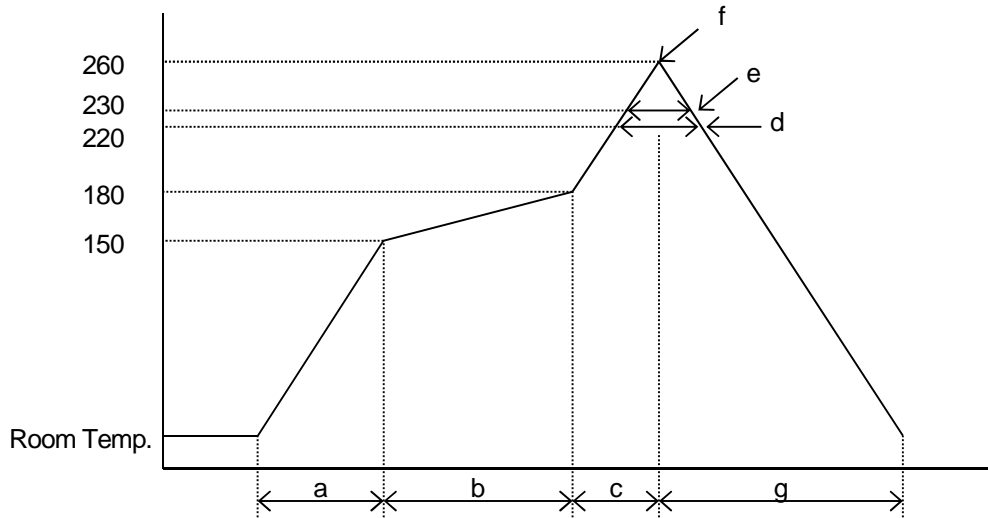

- | | |
|---------------------------------|---------------------------|
| a: Temperature ramping rate | : 1 to 4 /s |
| b: Pre-heating temperature time | : 150 to 180 : 60 to 120s |
| c: Temperature ramp rate | : 1 to 4 /s |
| d: 220 or higher time | : Shorter than 60s |
| e: 230 or higher time | : Shorter than 40s |
| f: Peak temperature | : Lower than 260 |
| g: Temperature ramping rate | : 1 to 6 /s |

The temperature indicates at the surface of mold package.

[CAUTION]

1. New JRC strives to produce reliable and high quality semiconductors. New JRC's semiconductors are intended for specific applications and require proper maintenance and handling. To enhance the performance and service of New JRC's semiconductors, the devices, machinery or equipment into which they are integrated should undergo preventative maintenance and inspection at regularly scheduled intervals. Failure to properly maintain equipment and machinery incorporating these products can result in catastrophic system failures
2. The specifications on this datasheet are only given for information without any guarantee as regards either mistakes or omissions. The application circuits in this datasheet are described only to show representative usages of the product and not intended for the guarantee or permission of any right including the industrial rights. All other trademarks mentioned herein are property of their respective companies.
3. To ensure the highest levels of reliability, New JRC products must always be properly handled. The introduction of external contaminants (e.g. dust, oil or cosmetics) can result in failures of semiconductor products.
4. New JRC offers a variety of semiconductor products intended for particular applications. It is important that you select the proper component for your intended application. You may contact New JRC's Sale's Office if you are uncertain about the products listed in this catalog.
5. Special care is required in designing devices, machinery or equipment which demand high levels of reliability. This is particularly important when designing critical components or systems whose failure can foreseeably result in situations that could adversely affect health or safety. In designing such critical devices, equipment or machinery, careful consideration should be given to amongst other things, their safety design, fail-safe design, back-up and redundancy systems, and diffusion design.
6. The products listed in the catalog may not be appropriate for use in certain equipment where reliability is critical or where the products may be subjected to extreme conditions. You should consult our sales office before using the products in any of the following types of equipment.

Aerospace Equipment
Equipment Used in the Deep sea
Power Generator Control Equipment (Nuclear, Steam, Hydraulic)
Life Maintenance Medical Equipment
Fire Alarm/Intruder Detector
Vehicle Control Equipment (airplane, railroad, ship, etc.)
Various Safety devices

7. New JRC's products have been designed and tested to function within controlled environmental conditions. Do not use products under conditions that deviate from methods or applications specified in this catalog. Failure to employ New JRC products in the proper applications can lead to deterioration, destruction or failure of the products. New JRC shall not be responsible for any bodily injury, fires or accident, property damage or any consequential damages resulting from misuse or misapplication of its products. Products are sold without warranty of any kind, either express or implied, including but not limited to any implied warranty of merchantability or fitness for a particular purpose.
8. Warning for handling Gallium and Arsenic(GaAs) Products (Applying to GaAs MMIC, Photo Reflector). This Products uses Gallium(Ga) and Arsenic(As) which are specified as poisonous chemicals by law. For the prevention of a hazard, do not burn, destroy, or process chemically to make them as gas or power. When the product is disposed, please follow the related regulation and do not mix this with general industrial waste or household waste.
9. The product specifications and descriptions listed in this catalog are subject to change at any time, without notice.



Mouser Electronics

Authorized Distributor

Click to View Pricing, Inventory, Delivery & Lifecycle Information:

[NJR:](#)

[NJM2575F1-TE2](#) [NJM2575F1-TE1](#) [NJM2575F1](#)



Стандарт Электрон Связь

Мы молодая и активно развивающаяся компания в области поставок электронных компонентов. Мы поставляем электронные компоненты отечественного и импортного производства напрямую от производителей и с крупнейших складов мира.

Благодаря сотрудничеству с мировыми поставщиками мы осуществляем комплексные и плановые поставки широчайшего спектра электронных компонентов.

Собственная эффективная логистика и склад в обеспечивает надежную поставку продукции в точно указанные сроки по всей России.

Мы осуществляем техническую поддержку нашим клиентам и предпродажную проверку качества продукции. На все поставляемые продукты мы предоставляем гарантию .

Осуществляем поставки продукции под контролем ВП МО РФ на предприятия военно-промышленного комплекса России , а также работаем в рамках 275 ФЗ с открытием отдельных счетов в уполномоченном банке. Система менеджмента качества компании соответствует требованиям ГОСТ ISO 9001.

Минимальные сроки поставки, гибкие цены, неограниченный ассортимент и индивидуальный подход к клиентам являются основой для выстраивания долгосрочного и эффективного сотрудничества с предприятиями радиоэлектронной промышленности, предприятиями ВПК и научно-исследовательскими институтами России.

С нами вы становитесь еще успешнее!

Наши контакты:

Телефон: +7 812 627 14 35

Электронная почта: sales@st-electron.ru

Адрес: 198099, Санкт-Петербург,
Промышленная ул, дом № 19, литера Н,
помещение 100-Н Офис 331