

1:10 LOW JITTER UNIVERSAL BUFFER/LEVEL TRANSLATOR WITH 2:1 INPUT MUX AND INDIVIDUAL OE (<1.25 GHz)

Features

- 10 differential or 20 LVCMOS outputs
- Ultra-low additive jitter: 100 fs rms
- Wide frequency range: 1 MHz to 1.25 GHz
- Any-format input with pin selectable output formats: LVPECL, Low Power LVPECL, LVDS, CML, HCSL, LVCMOS
- 2:1 mux with hot-swappable inputs
- Asynchronous output enable
- Individual output enable
- Low output-output skew: <50 ps
- Low propagation delay variation: <400 ps
- Independent V_{DD} and V_{DDO} : 1.8/2.5/3.3 V
- Excellent power supply noise rejection (PSRR)
- Selectable LVCMOS drive strength to tailor jitter and EMI performance
- Small size: 44-QFN (7 mm x 7 mm)
- RoHS compliant, Pb-free
- Industrial temperature range: -40 to +85 °C

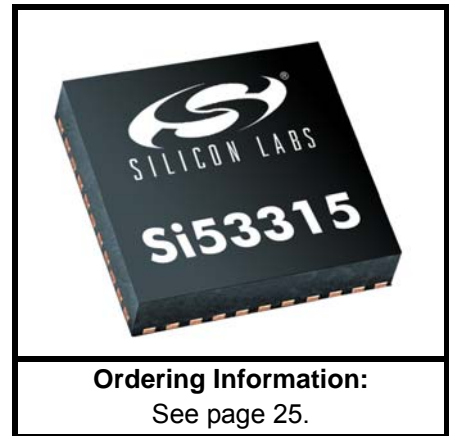

Applications

- High-speed clock distribution
- Ethernet switch/router
- Optical Transport Network (OTN)
- SONET/SDH
- PCI Express Gen 1/2/3
- Storage
- Telecom
- Industrial
- Servers
- Backplane clock distribution

Description

The Si53315 is an ultra low jitter ten output differential buffer with pin-selectable output clock signal format and individual OE. The Si53315 features a 2:1 mux, making it ideal for redundant clocking applications. The Si53315 utilizes Silicon Laboratories' advanced CMOS technology to fanout clocks from 1 MHz to 1.25 GHz with guaranteed low additive jitter, low skew, and low propagation delay variability. The Si53315 features minimal cross-talk and provides superior supply noise rejection, simplifying low jitter clock distribution in noisy environments. Independent core and output bank supply pins provide integrated level translation without the need for external circuitry.

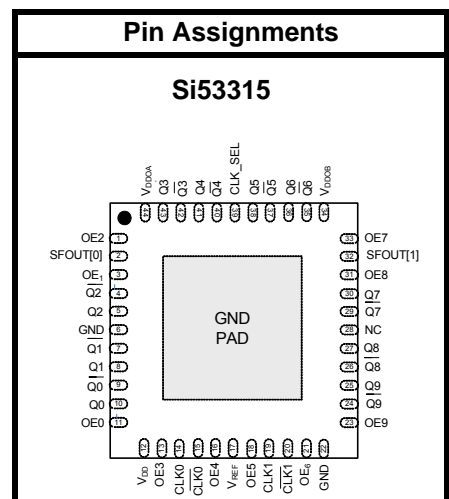

Patents pending

Functional Block Diagram

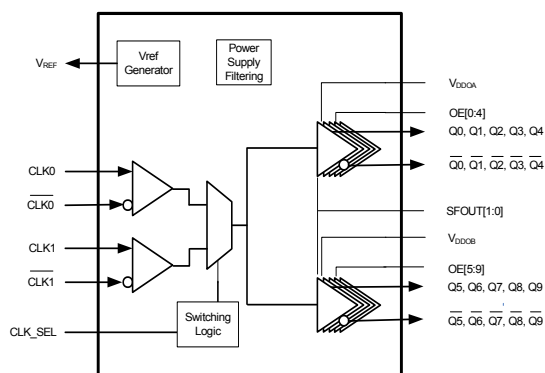

TABLE OF CONTENTS

<u>Section</u>	<u>Page</u>
1. Electrical Specifications	3
2. Functional Description	10
2.1. Universal, Any-Format Input	10
2.2. Input Bias Resistors	12
2.3. Universal, Any-Format Output Buffer	12
2.4. Input Mux and Output Enable Logic	13
2.5. Power Supply (V_{DD} and V_{DDOX})	13
2.6. Output Clock Termination Options	14
2.7. AC Timing Waveforms	17
2.8. Typical Phase Noise Performance	18
2.9. Input Mux Noise Isolation	19
2.10. Power Supply Noise Rejection	20
3. Pin Description: 44-Pin QFN	21
4. Ordering Guide	25
5. Package Outline	26
5.1. 7x7 mm 44-QFN Package Diagram	26
6. PCB Land Pattern	27
6.1. 7x7 mm 44-QFN Package Land Pattern	27
7. Top Marking	28
7.1. Si53315 Top Marking	28
7.2. Top Marking Explanation	28
Contact Information	30

1. Electrical Specifications

Table 1. Recommended Operating Conditions

Parameter	Symbol	Test Condition	Min	Typ	Max	Unit
Ambient Operating Temperature	T_A		-40	—	85	°C
Supply Voltage Range*	V_{DD}	LVDS, CML, HCSSL, LVCMOS	1.71	1.8	1.89	V
		LVPECL, low power LVPECL, LVDS, CML, HCSSL, LVCMOS	2.38	2.5	2.63	V
			2.97	3.3	3.63	V
Output Buffer Supply Voltage*	V_{DDO}	LVDS, CML, HCSSL, LVCMOS	1.71	—	1.89	V
		LVPECL, low power LVPECL, LVDS, CML, HCSSL, LVCMOS	2.38	—	2.63	V
			2.97	—	3.63	V

***Note:** Core supply V_{DD} and output buffer supplies V_{DDO} are independent.

Table 2. Input Clock Specifications

($V_{DD} = 1.8\text{ V} \pm 5\%$, $2.5\text{ V} \pm 5\%$, or $3.3\text{ V} \pm 10\%$, $T_A = -40$ to $85\text{ }^\circ\text{C}$)

Parameter	Symbol	Test Condition	Min	Typ	Max	Unit
Differential Input Common Mode Voltage	V_{CM}	$V_{DD} = 2.5\text{ V} \pm 5\%$, $3.3\text{ V} \pm 10\%$	0.05	—	—	V
Input Swing (single-ended, peak-to-peak)	V_{IN}		0.1	—	1.1	V
Input Voltage High	V_{IH}		$V_{DD} \times 0.7$	—	—	V
Input Voltage Low	V_{IL}		—	—	$V_{DD} \times 0.3$	V
Input Capacitance	C_{IN}		—	5	—	pF

Table 3. DC Common Characteristics

($V_{DD} = 1.8\text{ V} \pm 5\%$, $2.5\text{ V} \pm 5\%$, or $3.3\text{ V} \pm 10\%$, $T_A = -40\text{ to }85\text{ }^\circ\text{C}$)

Parameter	Symbol	Test Condition	Min	Typ	Max	Unit
Supply Current	I_{DD}		—	TBD	100	mA
Output Buffer Supply Current (Per Clock Output) @100 MHz	I_{DDOX}	LVPECL (3.3 V)	—	35	—	mA
		Low Power LVPECL (3.3 V)	—	30	—	mA
		LVDS (3.3 V)	—	20	—	mA
		CML (3.3 V)	—	30	—	mA
		HCSL, 100 MHz, 2 pF load (3.3 V)	—	35	—	mA
		CMOS (1.8 V, SFOUT = Open/0), per output, $C_L = 5\text{ pF}$, 200 MHz	—	5	—	mA
		CMOS (2.5 V, SFOUT = Open/0), per output, $C_L = 5\text{ pF}$, 200 MHz	—	8	—	mA
Leakage Current	I_L	Input leakage at all inputs except CLKIN, $V_{IN} = 0\text{ V}$	—	—	TBD	μA
		Input leakage at CLKIN $V_{IN} = 0\text{ V}$	—	—	TBD	μA
Voltage Reference	V_{REF}	V_{REF} pin	—	$V_{DD}/2$	—	V
Input High Voltage	V_{IH}	SFOUTX, DIVX 3-level input pins	$0.85 \times V_{DD}$	—	—	V
Input Mid Voltage	V_{IM}	SFOUTX, DIVX 3-level input pins	$0.45 \times V_{DD}$	$0.5 \times V_{DD}$	$0.55 \times V_{DD}$	V
Input Low Voltage	V_{IL}	SFOUTX, DIVXpin 3-level input pins	—	—	$0.15 \times V_{DD}$	V
Internal Pull-down Resistor	R_{DOWN}	CLK_SEL, DIVA, DIVB, SFOUTA[1], SFOUTB[1]	—	25	—	k Ω
Internal Pull-up Resistor	R_{UP}	SFOUTA[1], SFOUTB[1], DIVA, DIVB, OEX, OEX	—	25	—	k Ω

Table 4. DC Characteristics—LVPECL and Low Power LVPECL $(V_{DD} = 2.5\text{ V} \pm 5\%$, or $3.3\text{ V} \pm 10\%$, $T_A = -40$ to $85\text{ }^\circ\text{C}$)

Parameter	Symbol	Test Condition	Min	Typ	Max	Unit
Output Voltage High	V_{OH}	$R_L = 50\ \Omega$ to $V_{DDOX} - 2\text{ V}$	$V_{DDOX} - 1.145$	—	$V_{DDOX} - 0.895$	V
Output Voltage Low	V_{OL}	$R_L = 50\ \Omega$ to $V_{DDOX} - 2\text{ V}$	$V_{DDOX} - 1.945$	—	$V_{DDOX} - 1.695$	V
Output DC Common Mode Voltage	V_{COM}		$V_{DDOX} - 1.895$	—	$V_{DDOX} - 1.425$	V
Single-Ended Output Swing	V_{SE}	Terminate unused outputs to $R_L = 50\ \Omega$ to $V_{DDOX} - 2\text{ V}$	0.25	0.60	0.85	V

Table 5. DC Characteristics—CML $(V_{DD} = 1.8\text{ V} \pm 5\%$, $2.5\text{ V} \pm 5\%$, or $3.3\text{ V} \pm 10\%$, $T_A = -40$ to $85\text{ }^\circ\text{C}$)

Parameter	Symbol	Test Condition	Min	Typ	Max	Unit
Single-Ended Output Swing	V_{SE}	Terminated as shown in Figure 6 (CML termination).	300	400	500	mV

Table 6. DC Characteristics—LVDS $(V_{DD} = 1.8\text{ V} \pm 5\%$, $2.5\text{ V} \pm 5\%$, or $3.3\text{ V} \pm 10\%$, $T_A = -40$ to $85\text{ }^\circ\text{C}$)

Parameter	Symbol	Test Condition	Min	Typ	Max	Unit
Single-Ended Output Swing	V_{SE}	$R_L = 100\ \Omega$ across Q_N and \overline{Q}_N	247	—	454	mV
Output Common Mode Voltage ($V_{DDO} = 2.5\text{ V}$ or 3.3 V)	V_{COM1}	$V_{DDOX} = 2.38$ to 2.63 V , 2.97 to 3.63 V , $R_L = 100\ \Omega$ across Q_N and \overline{Q}_N	1.10	1.25	1.35	V
Output Common Mode Voltage ($V_{DDO} = 1.8\text{ V}$)	V_{COM2}	$V_{DDOX} = 1.71$ to 1.89 V , $R_L = 100\ \Omega$ across Q_N and \overline{Q}_N	0.85	0.97	1.10	V

Table 7. DC Characteristics—LVCMOS

($V_{DD} = 1.8\text{ V} \pm 5\%$, $2.5\text{ V} \pm 5\%$, or $3.3\text{ V} \pm 10\%$, $T_A = -40$ to $85\text{ }^\circ\text{C}$)

Parameter	Symbol	Test Condition	Min	Typ	Max	Unit
Output Voltage High*	V_{OH}		$0.8 \times V_{DDOX}$	—	—	V
Output Voltage Low*	V_{OL}		—	—	$0.2 \times V_{DDOX}$	V

*Note: I_{OH} and I_{OL} per the Output Signal Format Table for specific V_{DDOX} and SFOUTX settings.

Table 8. DC Characteristics—HCSL

($V_{DD} = 1.8\text{ V} \pm 5\%$, $2.5\text{ V} \pm 5\%$, or $3.3\text{ V} \pm 10\%$, $T_A = -40$ to $85\text{ }^\circ\text{C}$)

Parameter	Symbol	Test Condition	Min	Typ	Max	Unit
Output Voltage High	V_{OH}	$R_L = 50\ \Omega$ to GND	550	700	850	mV
Output Voltage Low	V_{OL}	$R_L = 50\ \Omega$ to GND	-150	0	150	mV
Single-Ended Output Swing	V_{SE}	$R_L = 50\ \Omega$ to GND	—	700	—	mV
Crossing Voltage	V_C	$R_L = 50\ \Omega$ to GND	250	350	550	mV

Table 9. AC Characteristics(V_{DD} = 1.8 V ± 5%, 2.5 V ± 5%, or 3.3 V ± 10%, T_A = -40 to 85 °C)

Parameter	Symbol	Test Condition	Min	Typ	Max	Unit
Frequency	F	LVPECL, low power LVPECL, LVDS, CML, HCSL	1	—	1250	MHz
		LVC MOS	1	—	200	MHz
Duty Cycle Note: 50% input duty cycle.	D _C	200 MHz, 50 Ω to V _{DD} /2, 20/80% T _R /T _F < 10% of period (LVC MOS)	TBD	TBD	TBD	%
		20/80% T _R /T _F < 10% of period (Differential)	48	50	52	%
Minimum Input Clock Slew Rate ¹	SR	Required to meet prop delay and additive jitter specifications (20–80%)	0.75	—	—	V/ns
Output Rise/Fall Time	T _R /T _F	LVPECL, LVDS, CML, HCSL, 20/80%			350	ps
		200 MHz, 50 Ω, 20/80%, 2 pF load (LVC MOS)	TBD	TBD	750	ps
Minimum Input Pulse Width	T _W		500	—	—	ps
Additive Jitter (Differential Clock Input)	J	V _{DD} = 2.5/3.3 V, LVPECL/LVDS, F = 725 MHz, 0.75 V/ns input slew rate	—	60	80	fs
Propagation Delay	T _{PLH} , T _{PHL}	Low to high, high to low Single-ended	TBD	—	TBD	ns
		Low to high, high to low Differential	TBD	—	TBD	ns
Output Enable Time ²	T _{EN}	F = 1 MHz	—	2	—	μs
		F = 100 MHz	—	60	—	ns
		F = 725 MHz	—	50	—	ns
Output Disable Time ²	T _{DIS}	F = 1 MHz	—	2	—	μs
		F = 100 MHz	—	25	—	ns
		F = 725 MHz	—	15	—	ns

Notes:

1. For clock division applications, a minimum input clock slew rate of 30 mV/ns is required.
2. See Figure 4.
3. Defined as skew between outputs on different devices operating at the same supply voltages, temperatures, and equal load conditions. Using the same type of inputs on each device, the outputs are measured at the differential cross points.
4. Measured for 156.25 MHz carrier frequency. Sine-wave noise added to V_{DDOX} (1.8 V = 50 mV_{PP}, 2.5/3.3 V = 100 mV_{PP}) and noise spur amplitude measured. See AN491 for further details.

Table 9. AC Characteristics (Continued)

($V_{DD} = 1.8\text{ V} \pm 5\%$, $2.5\text{ V} \pm 5\%$, or $3.3\text{ V} \pm 10\%$, $T_A = -40$ to $85\text{ }^\circ\text{C}$)

Parameter	Symbol	Test Condition	Min	Typ	Max	Unit
Output to Output Skew	T_{SK}	Identical Configuration, Single-ended (Q_N to Q_M)	—	—	100	ps
		Identical Configuration, Differential (Q_N to Q_M)	—	—	50	ps
Part to Part Skew ³	T_{PS}	Identical configuration	—	50	—	ps
Power Supply Noise Rejection ⁴	PSRR	10 kHz sinusoidal noise	—	-90	—	dBc
		100 kHz sinusoidal noise	—	-90	—	dBc
		500 kHz sinusoidal noise	—	-80	—	dBc
		1 MHz sinusoidal noise	—	-70	—	dBc

Notes:

1. For clock division applications, a minimum input clock slew rate of 30 mV/ns is required.
2. See Figure 4.
3. Defined as skew between outputs on different devices operating at the same supply voltages, temperatures, and equal load conditions. Using the same type of inputs on each device, the outputs are measured at the differential cross points.
4. Measured for 156.25 MHz carrier frequency. Sine-wave noise added to V_{DDOX} ($1.8\text{ V} = 50\text{ mV}_{PP}$, $2.5/3.3\text{ V} = 100\text{ mV}_{PP}$) and noise spur amplitude measured. See AN491 for further details.

Table 10. Thermal Conditions

Parameter	Symbol	Test Condition	Value	Unit
Thermal Resistance, Junction to Ambient	θ_{JA}	Still air	46.2	°C/W
Thermal Resistance, Junction to Case	θ_{JC}	Still air	27.1	°C/W

Table 11. Absolute Maximum Ratings

Parameter	Symbol	Test Condition	Min	Typ	Max	Unit
Storage Temperature	T_S		-55	—	150	°C
Supply Voltage	V_{DD}		-0.5	—	3.8	V
Input Voltage	V_{IN}		-0.5	—	$V_{DD} + 0.3$	V
Output Voltage	V_{OUT}		—	—	$V_{DD} + 0.3$	V
ESD Sensitivity	HBM	HBM, 100 pF, 1.5 kΩ	2000	—	—	V
ESD Sensitivity	CDM		500	—	—	V
Peak Soldering Reflow Temperature	T_{PEAK}	Pb-Free; Solder reflow profile per JEDEC J-STD-020	—	—	260	°C
Maximum Junction Temperature	T_J		—	—	125	°C
Note: Stresses beyond those listed in this table may cause permanent damage to the device. Functional operation specification compliance is not implied at these conditions. Exposure to maximum rating conditions for extended periods may affect device reliability.						

2. Functional Description

The Si53315 is a low jitter, low skew 1:10 differential buffer with an integrated 2:1 input mux and individual OE control. The device has a universal input that accepts most common differential or LVCMOS input signals. A clock select pin is used to select the active input clock. The selected clock input is routed to two independent banks of outputs. Each output bank features control pins to select signal format and LVCMOS drive strength settings. In addition, each clock output has an independent OE pin for individual clock enable/disable.

2.1. Universal, Any-Format Input

The Si53315 has a universal input stage that enables simple interfacing to a wide variety of clock formats, including LVPECL, LVCMOS, LVDS, HCSL, and CML. Tables 12 and 13 summarize the various input ac- and dc-coupling options supported by the device. Figures 1 and 2 show the recommended input clock termination options.

Table 12. LVPECL, LVCMOS, and LVDS

	LVPECL		LVCMOS		LVDS	
	AC-Couple	DC-Couple	AC-Couple	DC-Couple	AC-Couple	DC-Couple
1.8 V	N/A	N/A	No	Yes	Yes	No
2.5/3.3 V	Yes	Yes	No	Yes	Yes	Yes

Table 13. HCSL and CML

	HCSL		CML	
	AC-Couple	DC-Couple	AC-Couple	DC-Couple
1.8 V	No	No	Yes	No
2.5/3.3 V	No	Yes (3.3 V)	Yes	No

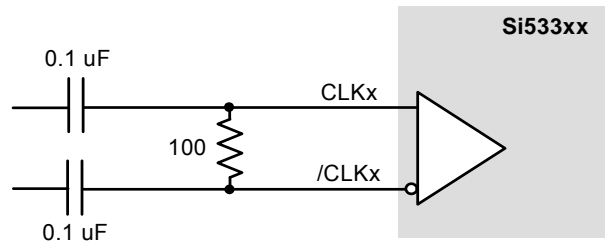

Figure 1. Differential LVPECL, LVDS, CML AC-Coupled Input Termination

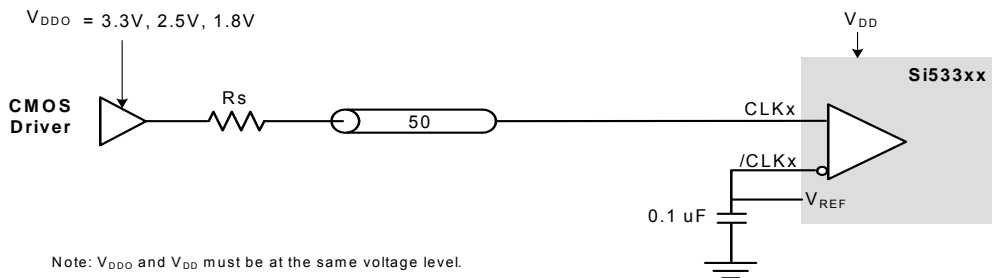
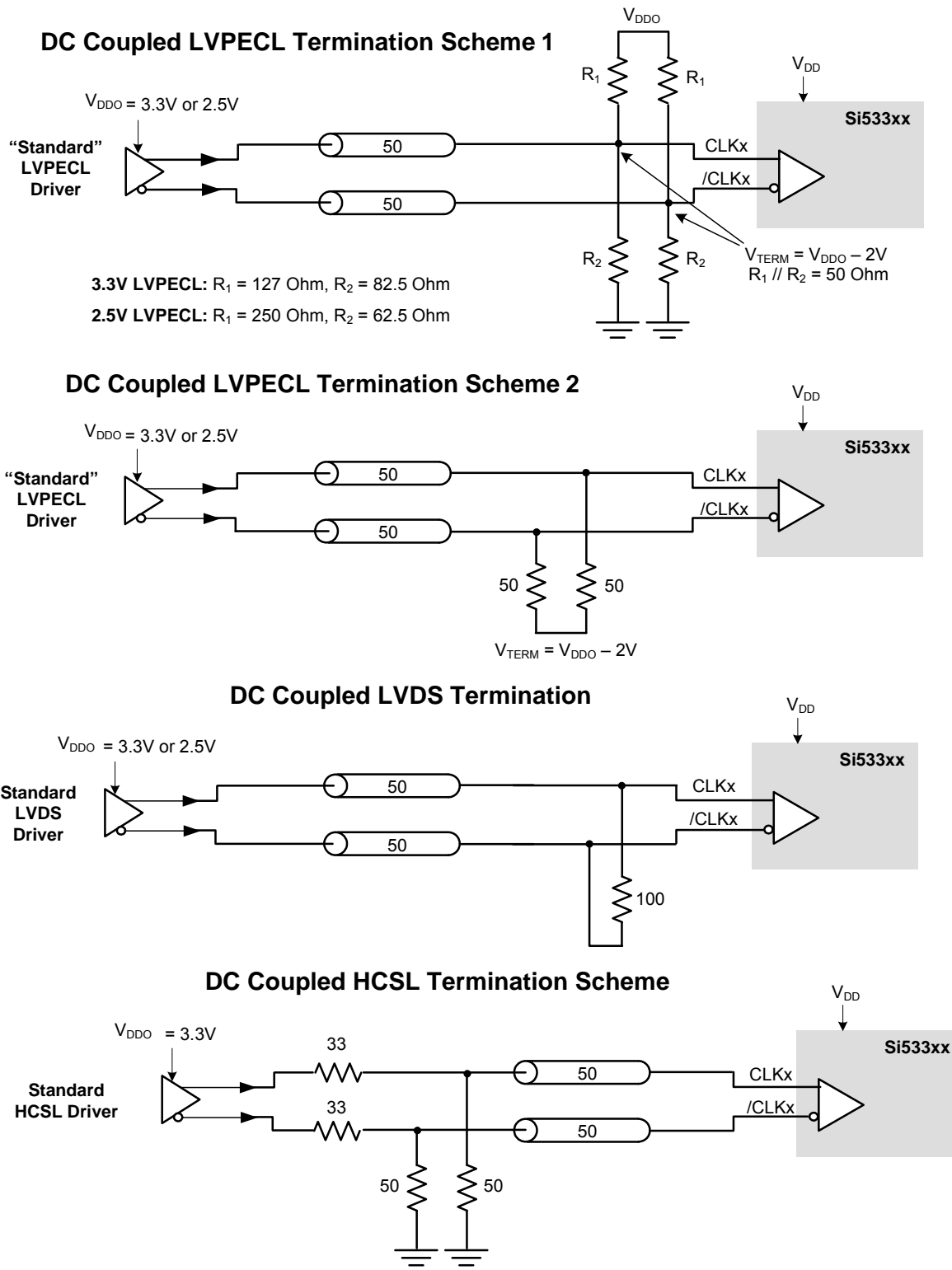

Figure 2. LVCMOS DC-Coupled Input Termination



Note: 33 Ohm series termination is optional depending on the location of the receiver.

Figure 3. Differential DC-Coupled Input Terminations

2.2. Input Bias Resistors

Internal bias resistors ensure a differential output low condition in the event that the clock inputs are not connected. The noninverting input is biased with a 18.75 kΩ pulldown to GND and a 75 kΩ pullup to V_{DD}. The inverting input is biased with a 75 kΩ pullup to V_{DD}.

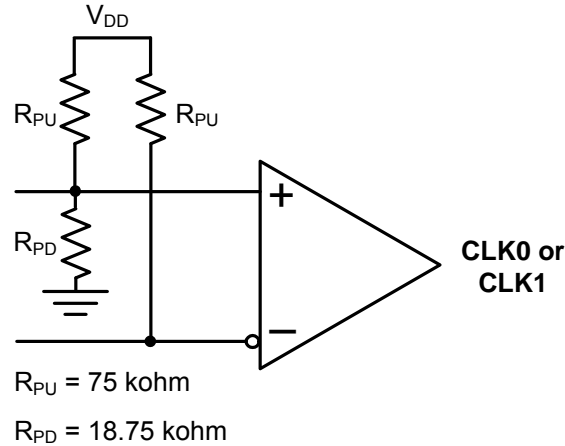

Figure 4. Input Bias Resistors

2.3. Universal, Any-Format Output Buffer

The Si53315 has highly flexible output drivers that support a wide range of clock signal formats, including LVPECL, low power LVPECL, LVDS, CML, HCSL, and LVCMOS. SFOUT[0] and SFOUT[1] are 3-level inputs that can be pin-strapped to select the clock signal formats for all of the outputs, Q0 through Q9. This feature enables the device to be used for format/level translation in addition to clock distribution, minimizing the number of unique buffer part numbers required in a typical application and simplifying design reuse. For EMI reduction applications, four LVCMOS drive strength options are available for each V_{DDO} setting.

Table 14. Output Signal Format Selection

SFOUT[1]	SFOUT[0]	V _{DDOX} = 3.3 V	V _{DDOX} = 2.5 V	V _{DDOX} = 1.8 V
Open*	Open*	LVPECL	LVPECL	N/A
0	0	LVDS	LVDS	LVDS
0	1	LVCMOS, 24 mA drive	LVCMOS, 18 mA drive	LVCMOS, 12 mA drive
1	0	LVCMOS, 18 mA drive	LVCMOS, 12 mA drive	LVCMOS, 9 mA drive
1	1	LVCMOS, 12 mA drive	LVCMOS, 9 mA drive	LVCMOS, 6 mA drive
Open*	0	LVCMOS, 6 mA drive	LVCMOS, 4 mA drive	LVCMOS, 2 mA drive
Open*	1	LVPECL Low power	LVPECL Low power	N/A
0	Open*	CML	CML	CML
1	Open*	HCSL	HCSL	HCSL

*Note: SFOUT[1:0] are 3-level input pins. Tie low for “0” setting. Tie high for “1” setting. When left open, the pin floats to V_{DD}/2.

2.4. Input Mux and Output Enable Logic

The Si53315 provides two clock inputs for applications that need to select between one of two clock sources. The CLK_SEL pin selects the active clock input. The table below summarizes the input and output clock based on the input mux and output enable pin settings.

Table 15. Input Mux and Output Enable Logic

CLK_SEL	CLK0	CLK1	OE ¹	Q ²
L	L	X	H	L
L	H	X	H	H
H	X	L	H	L
H	X	H	H	H
X	X	X	L	L ³

Notes:

1. Output enable active high
2. On the next negative transition of CLK0 or CLK1.
3. Single-end: Q=low, \overline{Q} =high
Differential: Q=low, \overline{Q} =high

2.5. Power Supply (V_{DD} and V_{DDOX})

The device includes separate core (V_{DD}) and output driver supplies (V_{DDOX}). This feature allows the core to operate at a lower voltage than V_{DDO} , reducing current consumption in mixed supply applications. The core V_{DD} supports 3.3, 2.5, or 1.8 V. Each output bank has its own V_{DDOX} supply, supporting 3.3, 2.5, or 1.8 V.

2.6. Output Clock Termination Options

The recommended output clock termination options are shown below. Unused output clocks should be left floating.

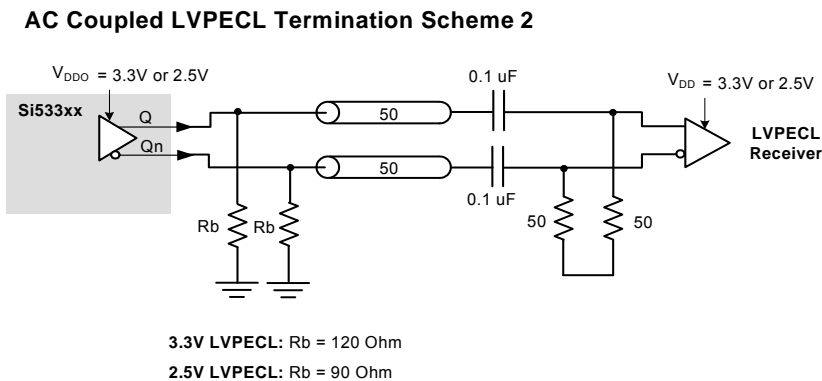
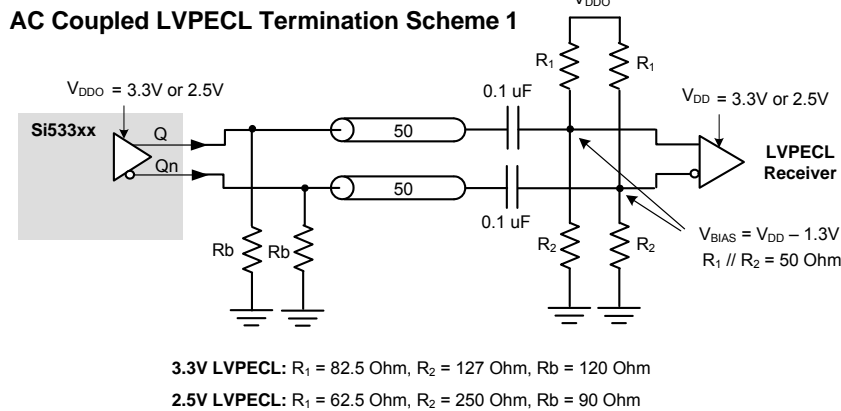
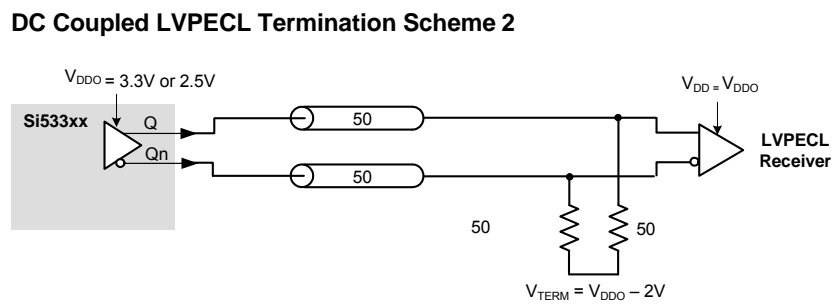
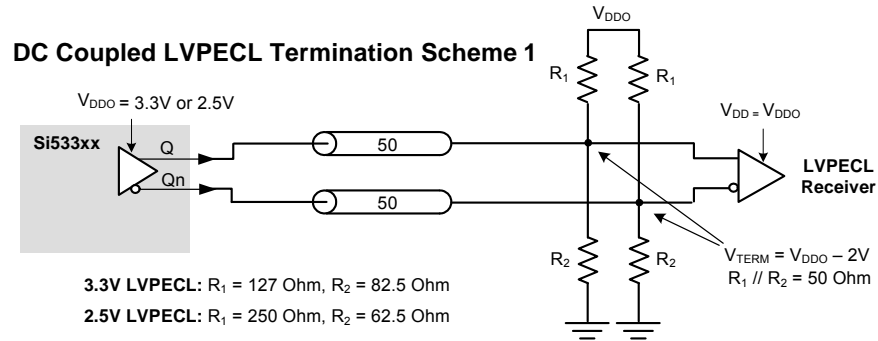

Figure 5. LVPECL Output Termination

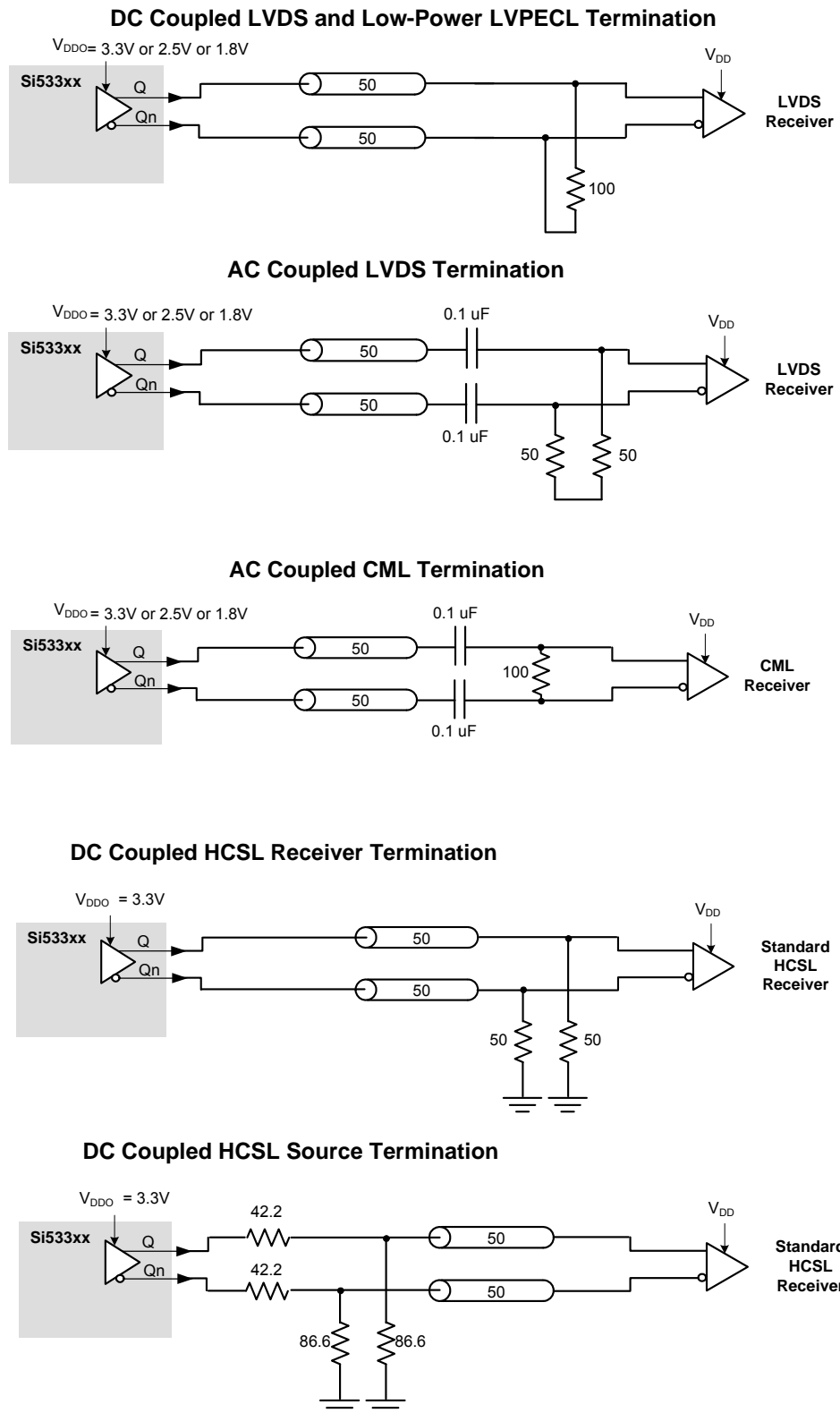

Figure 6. LVDS, CML, and HCSSL Output Termination

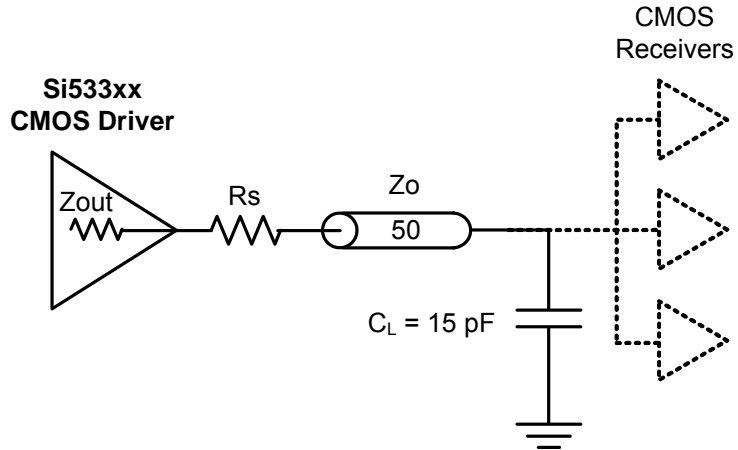

Figure 7. LVC MOS Output Termination

Table 16. Recommended LVC MOS R_S Series Termination

SFOUT[1]	SFOUT[0]	R_S (ohms)		
		3.3 V	2.5 V	1.8 V
0	1	33	33	33
1	0	33	33	33
1	1	0	0	0
Open	0	0	0	0

2.7. AC Timing Waveforms

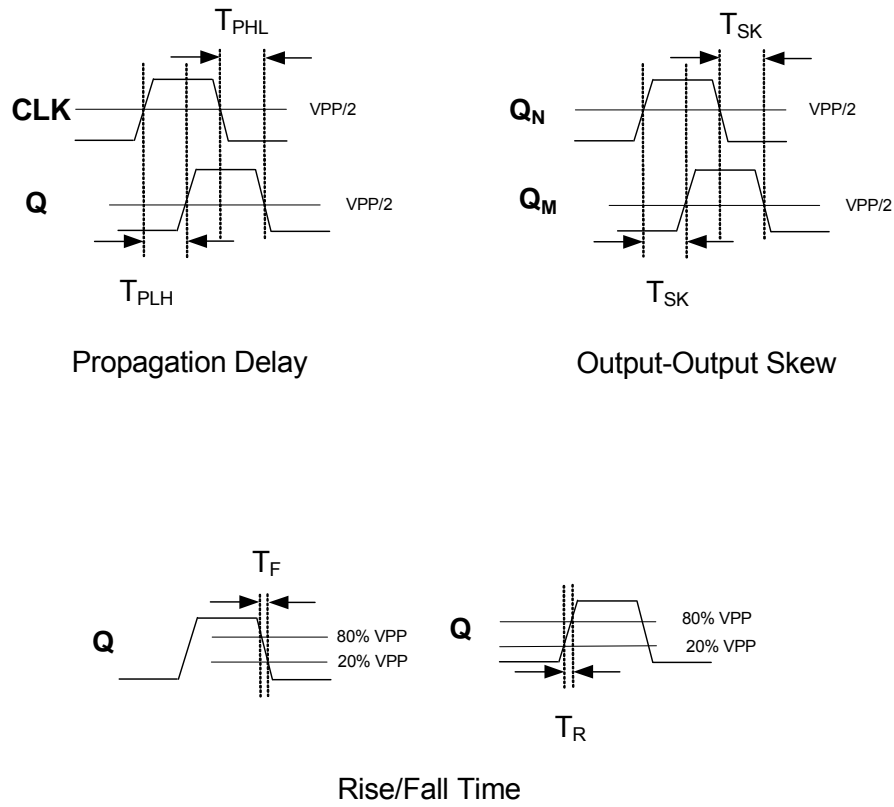
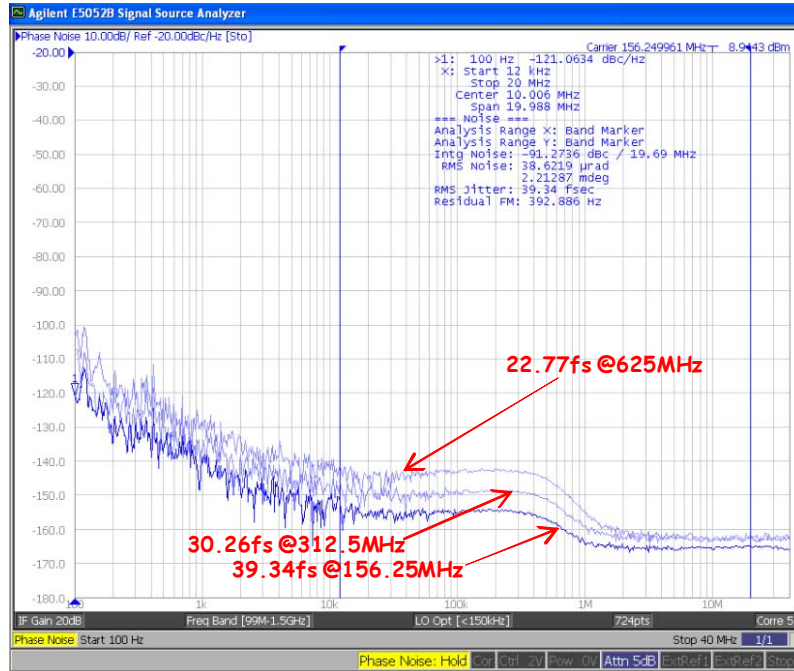
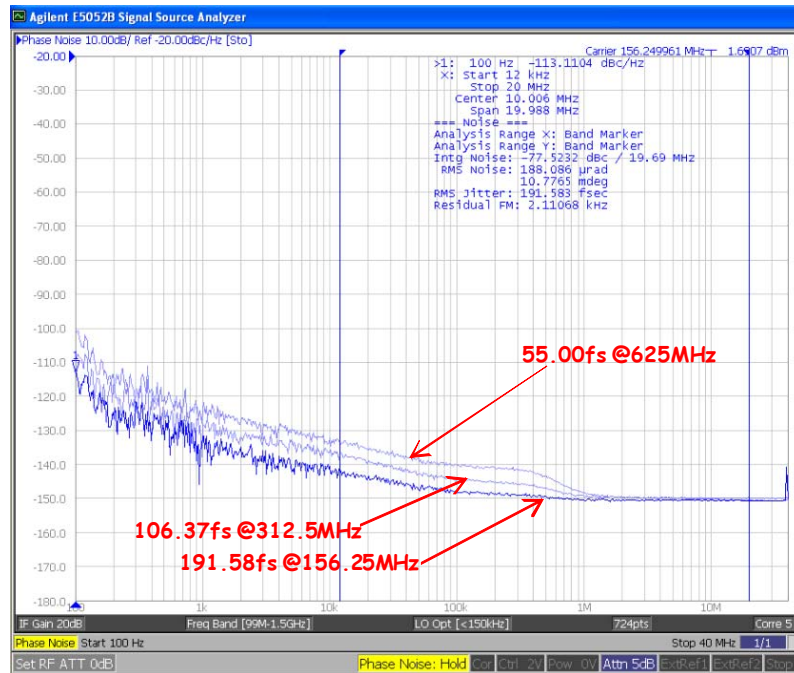

Figure 8. AC Waveforms

2.8. Typical Phase Noise Performance



Source Jitter



Total Jitter

Figure 9. Si53315 Phase Noise

Note: Measured single-endedly.

Table 17. Si53315 Additive Jitter

Frequency (MHz)	Source Jitter (fs)	Total Jitter (fs)	Additive Jitter (fs)
156.25	39.34	191.58	187.50
312.5	30.26	106.37	101.98
625	22.77	55.00	50.07

2.9. Input Mux Noise Isolation

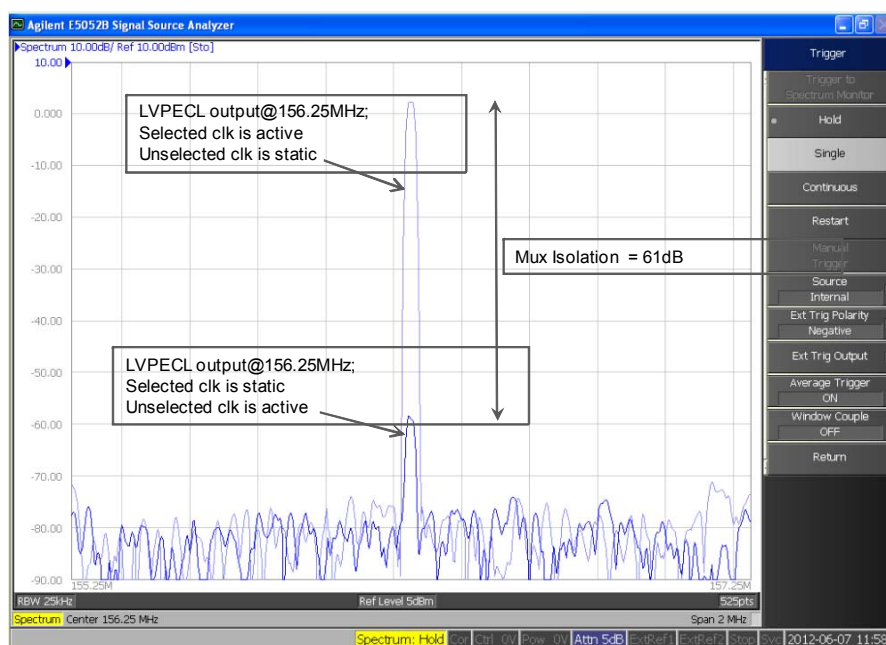

Figure 10. Input Mux Noise Isolation

2.10. Power Supply Noise Rejection

The device supports on-chip supply voltage regulation to reject noise present on the power supply, simplifying low jitter operation in real-world environments. This feature enables robust operation alongside FPGAs, ASICs and SoCs and may reduce board-level filtering requirements. For more information, see AN491: Power Supply Rejection for Low Jitter Clocks.

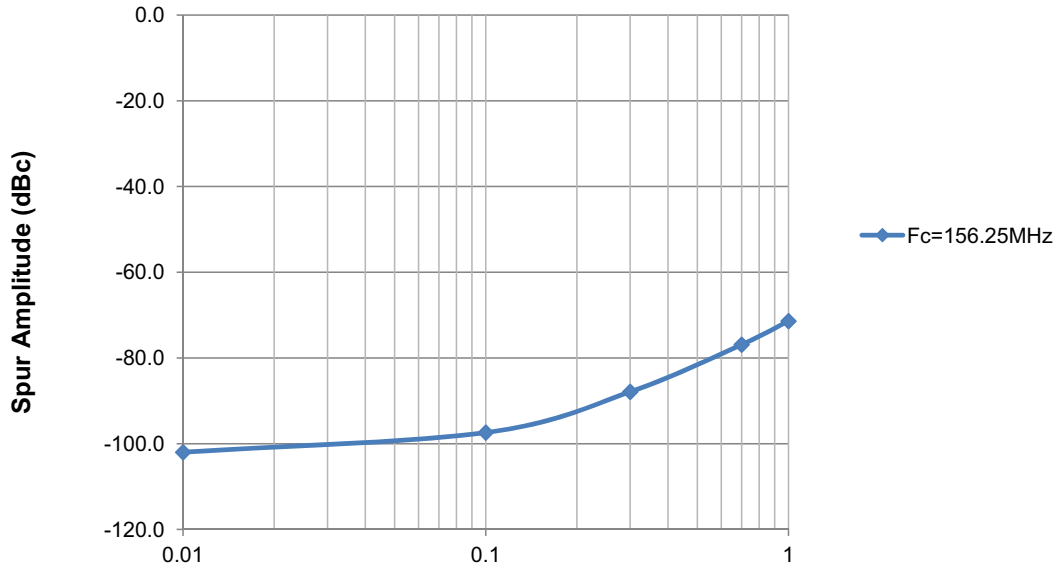

Figure 11. Power Supply Noise Rejection (100 mVpp Sinusoidal Power Supply Noise Applied)

3. Pin Description: 44-Pin QFN

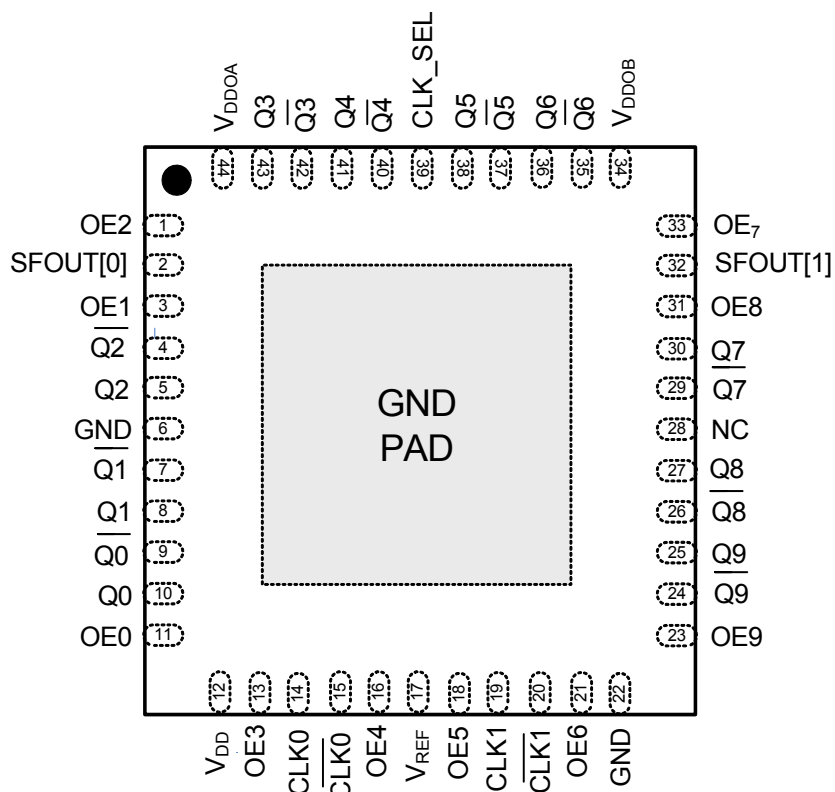

Table 18. Pin Description

Pin #	Name	Description
1	OE2	Output enable—Output 2 When OE = high, the Q2 is enabled. When OE = low, Q is held low, and \bar{Q} is held high for differential formats. For LVCMOS, both Q and \bar{Q} are held low when OE is set low. OE2 contains an internal pull-up resistor.
2	SFOUT[0]	Output signal format control pin [0] Three-level input control. Internally biased at $V_{DD}/2$. Can be left floating or tied to ground or V_{DD} .
3	OE1	Output enable—Output 1 When OE = high, the Q1 is enabled. When OE = low, Q is held low, and \bar{Q} is held high for differential formats. For LVCMOS, both Q and \bar{Q} are held low when OE is set low. OE1 contains an internal pull-up resistor.
4	$\bar{Q}2$	Output clock 2 (complement)
5	Q2	Output clock 2
6	GND	Ground
7	$\bar{Q}1$	Output clock 1 (complement)

Table 18. Pin Description (Continued)

8	Q1	Output clock 1
9	$\overline{Q0}$	Output clock 0 (complement)
10	Q0	Output clock 0
11	OE0	Output enable—Output 0 When OE = high, the Q0 is enabled. When OE = low, Q is held low, and \overline{Q} is held high for differential formats. For LVCMOS, both Q and \overline{Q} are held low when OE is set low. OE0 contains an internal pull-up resistor.
12	V _{DD}	Core voltage supply Bypass with 1.0 μ F capacitor and place close to the V _{DD} pin as possible
13	OE3	Output Enable 3 When OE = high, the Q3 is enabled. When OE = low, Q is held low, and \overline{Q} is held high for differential formats. For LVCMOS, both Q and \overline{Q} are held low when OE is set low. OE3 contains an internal pull-up resistor.
14	CLK0	Input clock 0
15	$\overline{CLK0}$	Input clock 0 (complement) When CLK0 is driven by a single-ended input, connect V _{REF} to $\overline{CLK0}$. $\overline{CLK0}$ contains an internal pull-up resistor.
16	OE4	Output Enable 4 When OE = high, Q4 is enabled. When OE = low, Q is held low, and \overline{Q} is held high for differential formats. For LVCMOS, both Q and \overline{Q} are held low when OE is set low. OE4 contains an internal pull-up resistor.
17	V _{REF}	Input reference voltage When driven by a LVCMOS clock input, connect the unused clock input to V _{REF} and a 0.1 μ F cap to ground. When driven by a differential clock, do not connect the V _{REF} pin.
18	OE5	Output Enable 5 When OE = high, Q5 is enabled. When OE = low, Q is held low, and \overline{Q} is held high for differential formats. For LVCMOS, both Q and \overline{Q} are held low when OE is set low. OE5 contains an internal pull-up resistor.
19	CLK1	Input clock 1

Table 18. Pin Description (Continued)

20	$\overline{\text{CLK1}}$	Input clock 1 (complement) When CLK1 is driven by a single-ended input, connect V_{REF} to $\overline{\text{CLK1}}$. CLK1 contains an internal pull-up resistor
21	OE6	Output Enable 6 When OE = high, Q6 is enabled. When OE = low, Q is held low, and \overline{Q} is held high for differential formats. For LVCMOS, both Q and \overline{Q} are held low when OE is set low. OE6 contains an internal pull-up resistor.
22	GND	Ground
23	OE9	Output Enable 9 When OE = high, the Output 9 outputs are enabled. When OE = low, Q is held low, and \overline{Q} is held high for differential formats. For LVCMOS, both Q and \overline{Q} are held low when OE is set low. OE9 contains an internal pull-up resistor.
24	$\overline{Q9}$	Output clock 9 (complement)
25	Q9	Output clock 9
26	$\overline{Q8}$	Output clock 8 (complement)
27	Q8	Output clock 8
28	NC	No Connect
29	$\overline{Q7}$	Output clock 7 (complement)
30	Q7	Output clock 7
31	OE8	Output Enable 8 When OE = high, Q8 is enabled. When OE = low, Q is held low, and \overline{Q} is held high for differential formats. For LVCMOS, both Q and \overline{Q} are held low when OE is set low. OE8 contains an internal pull-up resistor.
32	SFOUT[1]	Output signal format control pin [1] Three-level input control. Internally biased at $V_{\text{DD}}/2$. Can be left floating or tied to ground or V_{DD} .
33	OE7	Output Enable 7 When OE = high, Q7 is enabled. When OE = low, Q is held low, and \overline{Q} is held high for differential formats. For LVCMOS, both Q and \overline{Q} are held low when OE is set low. OE7 contains an internal pull-up resistor.
34	V_{DDOB}	Output voltage supply – Bank B (Outputs Q5 through Q9) Bypass with 1.0 μF capacitor and place as close to V_{DDOB} pin as possible.
35	$\overline{Q6}$	Output clock 6 (complement)

Table 18. Pin Description (Continued)

36	Q6	Output clock 6
37	$\overline{Q5}$	Output clock 5 (complement)
38	Q5	Output clock 5
39	CLK_SEL	MUX input select pin (LVCMOS) When CLK_SEL is high, CLK1 is selected When CLK_SEL is low, CLK0 is selected CLK_SEL contains an internal pull-down resistor
40	$\overline{Q4}$	Output clock 4 (complement)
41	Q4	Output clock 4
42	$\overline{Q3}$	Output clock 3 (complement)
43	Q3	Output clock 3
44	V _{DDOA}	Output voltage supply – Bank A (Outputs Q0 to Q4) Bypass with 1.0 μ F capacitor and place as close to V _{DDOA} pin as possible.
GND Pad	GND	Ground Pad Power supply ground and thermal relief

4. Ordering Guide

Part Number	Package	PB-Free, ROHS-6	Temperature
Si53315-B-GM	44-QFN	Yes	-40 to 85 °C

5. Package Outline

5.1. 7x7 mm 44-QFN Package Diagram

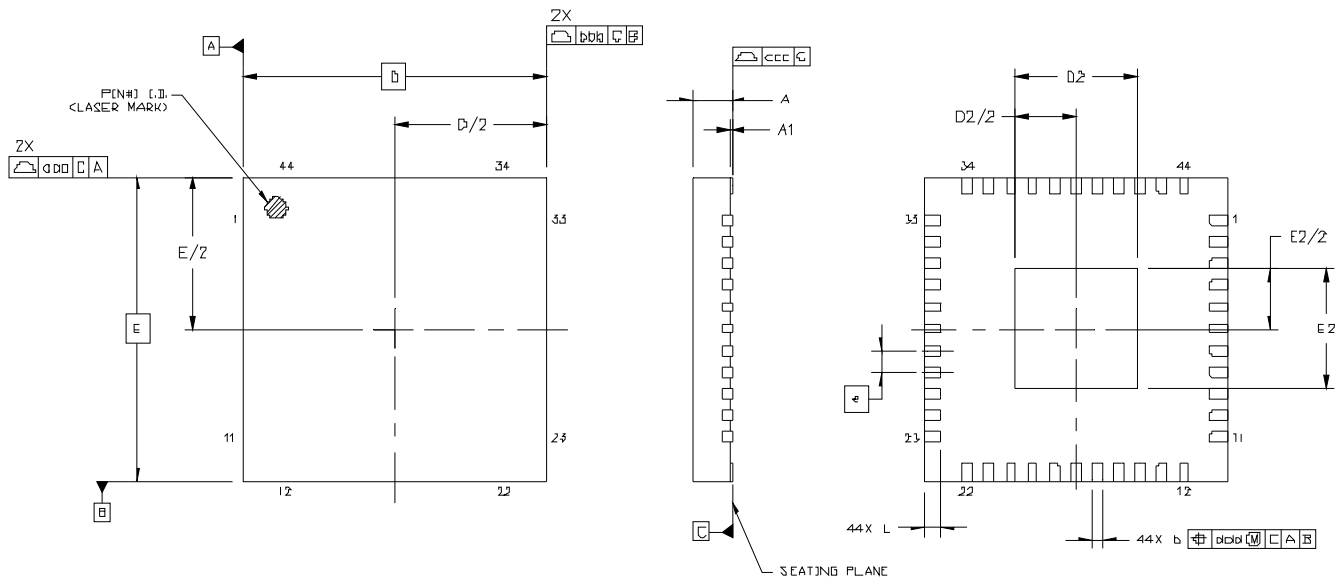

Figure 12. Si53315 7x7 mm 44-QFN Package Diagram

Table 19. Package Diagram Dimensions

Dimension	MIN	NOM	MAX
A	0.80	0.85	0.90
A1	0.00	0.02	0.05
b	0.18	0.25	0.30
D	7.00 BSC		
D2	2.65	2.80	2.95
e	0.50 BSC		
E	7.00 BSC		
E2	2.65	2.80	2.95
L	0.30	0.40	0.50
aaa	—	—	0.10
bbb	—	—	0.10
ccc	—	—	0.08
ddd	—	—	0.10
Notes:			
1. All dimensions shown are in millimeters (mm) unless otherwise noted.			
2. Dimensioning and Tolerancing per ANSI Y14.5M-1994.			
3. This drawing conforms to the JEDEC Solid State Outline MO-220.			
4. Recommended card reflow profile is per the JEDEC/IPC J-STD-020 specification for Small Body Components.			

6. PCB Land Pattern

6.1. 7x7 mm 44-QFN Package Land Pattern

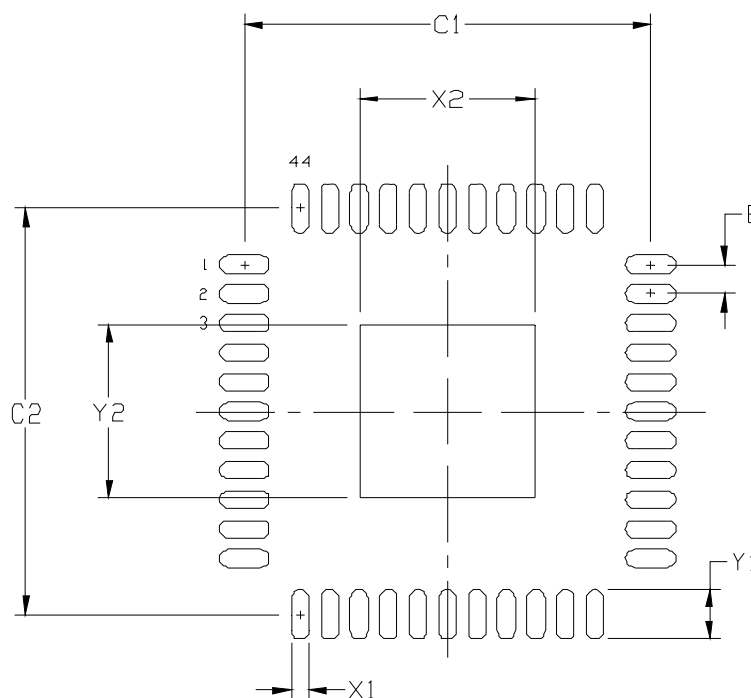

Figure 13. Si53315 7x7 mm 44-QFN Package Land Pattern

Table 20. PCB Land Pattern

Dimension	Min	Max	Dimension	Min	Max
C1	6.80	6.90	X2	2.85	2.95
C2	6.80	6.90	Y1	0.75	0.85
E	0.50 BSC		Y2	2.85	2.95
X1	0.20	0.30			

Notes:

General

1. All dimensions shown are in millimeters (mm) unless otherwise noted.
2. This Land Pattern Design is based on the IPC-7351 guidelines.

Solder Mask Design

1. All metal pads are to be non-solder mask defined (NSMD). Clearance between the solder mask and the metal pad is to be 60 μm minimum, all the way around the pad.

Stencil Design

1. A stainless steel, laser-cut and electro-polished stencil with trapezoidal walls should be used to assure good solder paste release.
2. The stencil thickness should be 0.125 mm (5 mils).
3. The ratio of stencil aperture to land pad size should be 1:1 for all perimeter pads.
4. A 2x2 array of 1.0 mm square openings on 1.45 mm pitch should be used for the center ground pad.

Card Assembly

1. A No-Clean, Type-3 solder paste is recommended.
2. The recommended card reflow profile is per the JEDEC/IPC J-STD-020 specification for Small Body Components.

Si53315

7. Top Marking

7.1. Si53315 Top Marking



7.2. Top Marking Explanation

Mark Method:	Laser	
Font Size:	1.9 Point (26 mils) Right-Justified	
Line 1 Marking:	Device Part Number	53315-B-GM
Line 2 Marking:	YY = Year WW = Work Week	Assigned by Assembly Supplier. Corresponds to the year and work week of the mold date.
	TTTTTT = Mfg Code	Manufacturing Code from the Assembly Purchase Order form.
Line 3 Marking:	Circle = 1.3 mm Diameter Center-Justified	"e3" Pb-Free Symbol
	Country of Origin ISO Code Abbreviation	TW
Line 4 Marking	Circle = 0.75 mm Diameter Filled	Pin 1 Identification

NOTES:



ClockBuilder Pro

One-click access to Timing tools, documentation, software, source code libraries & more. Available for Windows and iOS (CBGo only).

www.silabs.com/CBPro



Timing Portfolio
www.silabs.com/timing



SW/HW
www.silabs.com/CBPro



Quality
www.silabs.com/quality



Support and Community
community.silabs.com

Disclaimer

Silicon Laboratories intends to provide customers with the latest, accurate, and in-depth documentation of all peripherals and modules available for system and software implementers using or intending to use the Silicon Laboratories products. Characterization data, available modules and peripherals, memory sizes and memory addresses refer to each specific device, and "Typical" parameters provided can and do vary in different applications. Application examples described herein are for illustrative purposes only. Silicon Laboratories reserves the right to make changes without further notice and limitation to product information, specifications, and descriptions herein, and does not give warranties as to the accuracy or completeness of the included information. Silicon Laboratories shall have no liability for the consequences of use of the information supplied herein. This document does not imply or express copyright licenses granted hereunder to design or fabricate any integrated circuits. The products must not be used within any Life Support System without the specific written consent of Silicon Laboratories. A "Life Support System" is any product or system intended to support or sustain life and/or health, which, if it fails, can be reasonably expected to result in significant personal injury or death. Silicon Laboratories products are generally not intended for military applications. Silicon Laboratories products shall under no circumstances be used in weapons of mass destruction including (but not limited to) nuclear, biological or chemical weapons, or missiles capable of delivering such weapons.

Trademark Information

Silicon Laboratories Inc., Silicon Laboratories, Silicon Labs, SiLabs and the Silicon Labs logo, CMEMS®, EFM, EFM32, EFR, Energy Micro, Energy Micro logo and combinations thereof, "the world's most energy friendly microcontrollers", Ember®, EZLink®, EZMac®, EZRadio®, EZRadioPRO®, DSPLL®, ISOmodem®, Precision32®, ProSLIC®, SiPHY®, USBXpress® and others are trademarks or registered trademarks of Silicon Laboratories Inc. ARM, CORTEX, Cortex-M3 and THUMB are trademarks or registered trademarks of ARM Holdings. Keil is a registered trademark of ARM Limited. All other products or brand names mentioned herein are trademarks of their respective holders.



Silicon Laboratories Inc.
400 West Cesar Chavez
Austin, TX 78701
USA

<http://www.silabs.com>



Стандарт Электрон Связь

Мы молодая и активно развивающаяся компания в области поставок электронных компонентов. Мы поставляем электронные компоненты отечественного и импортного производства напрямую от производителей и с крупнейших складов мира.

Благодаря сотрудничеству с мировыми поставщиками мы осуществляем комплексные и плановые поставки широчайшего спектра электронных компонентов.

Собственная эффективная логистика и склад в обеспечивает надежную поставку продукции в точно указанные сроки по всей России.

Мы осуществляем техническую поддержку нашим клиентам и предпродажную проверку качества продукции. На все поставляемые продукты мы предоставляем гарантию .

Осуществляем поставки продукции под контролем ВП МО РФ на предприятия военно-промышленного комплекса России , а также работаем в рамках 275 ФЗ с открытием отдельных счетов в уполномоченном банке. Система менеджмента качества компании соответствует требованиям ГОСТ ISO 9001.

Минимальные сроки поставки, гибкие цены, неограниченный ассортимент и индивидуальный подход к клиентам являются основой для выстраивания долгосрочного и эффективного сотрудничества с предприятиями радиоэлектронной промышленности, предприятиями ВПК и научно-исследовательскими институтами России.

С нами вы становитесь еще успешнее!

Наши контакты:

Телефон: +7 812 627 14 35

Электронная почта: sales@st-electron.ru

Адрес: 198099, Санкт-Петербург,
Промышленная ул, дом № 19, литера Н,
помещение 100-Н Офис 331