



**MCP6V01**  
**Thermocouple Auto-Zeroed**  
**Reference Design**

---

**Note the following details of the code protection feature on Microchip devices:**

- Microchip products meet the specification contained in their particular Microchip Data Sheet.
- Microchip believes that its family of products is one of the most secure families of its kind on the market today, when used in the intended manner and under normal conditions.
- There are dishonest and possibly illegal methods used to breach the code protection feature. All of these methods, to our knowledge, require using the Microchip products in a manner outside the operating specifications contained in Microchip's Data Sheets. Most likely, the person doing so is engaged in theft of intellectual property.
- Microchip is willing to work with the customer who is concerned about the integrity of their code.
- Neither Microchip nor any other semiconductor manufacturer can guarantee the security of their code. Code protection does not mean that we are guaranteeing the product as "unbreakable."

Code protection is constantly evolving. We at Microchip are committed to continuously improving the code protection features of our products. Attempts to break Microchip's code protection feature may be a violation of the Digital Millennium Copyright Act. If such acts allow unauthorized access to your software or other copyrighted work, you may have a right to sue for relief under that Act.

---

Information contained in this publication regarding device applications and the like is provided only for your convenience and may be superseded by updates. It is your responsibility to ensure that your application meets with your specifications. MICROCHIP MAKES NO REPRESENTATIONS OR WARRANTIES OF ANY KIND WHETHER EXPRESS OR IMPLIED, WRITTEN OR ORAL, STATUTORY OR OTHERWISE, RELATED TO THE INFORMATION, INCLUDING BUT NOT LIMITED TO ITS CONDITION, QUALITY, PERFORMANCE, MERCHANTABILITY OR FITNESS FOR PURPOSE. Microchip disclaims all liability arising from this information and its use. Use of Microchip devices in life support and/or safety applications is entirely at the buyer's risk, and the buyer agrees to defend, indemnify and hold harmless Microchip from any and all damages, claims, suits, or expenses resulting from such use. No licenses are conveyed, implicitly or otherwise, under any Microchip intellectual property rights.

**Trademarks**

The Microchip name and logo, the Microchip logo, Accuron, dsPIC, KEELOQ, KEELOQ logo, MPLAB, PIC, PICmicro, PICSTART, rfPIC, SmartShunt and UNI/O are registered trademarks of Microchip Technology Incorporated in the U.S.A. and other countries.

FilterLab, Linear Active Thermistor, MXDEV, MXLAB, SEEVAL, SmartSensor and The Embedded Control Solutions Company are registered trademarks of Microchip Technology Incorporated in the U.S.A.

Analog-for-the-Digital Age, Application Maestro, CodeGuard, dsPICDEM, dsPICDEM.net, dsPICworks, dsSPEAK, ECAN, ECONOMONITOR, FanSense, In-Circuit Serial Programming, ICSP, ICEPIC, Mindi, MiWi, MPASM, MPLAB Certified logo, MPLIB, MPLINK, mTouch, PICkit, PICDEM, PICDEM.net, PICTail, PIC<sup>32</sup> logo, PowerCal, PowerInfo, PowerMate, PowerTool, REAL ICE, rfLAB, Select Mode, Total Endurance, WiperLock and ZENA are trademarks of Microchip Technology Incorporated in the U.S.A. and other countries.

SQTP is a service mark of Microchip Technology Incorporated in the U.S.A.

All other trademarks mentioned herein are property of their respective companies.

© 2008, Microchip Technology Incorporated, Printed in the U.S.A., All Rights Reserved.

 Printed on recycled paper.

**QUALITY MANAGEMENT SYSTEM  
CERTIFIED BY DNV  
== ISO/TS 16949:2002 ==**

*Microchip received ISO/TS-16949:2002 certification for its worldwide headquarters, design and wafer fabrication facilities in Chandler and Tempe, Arizona; Gresham, Oregon and design centers in California and India. The Company's quality system processes and procedures are for its PIC<sup>®</sup> MCUs and dsPIC<sup>®</sup> DSCs, KEELOQ<sup>®</sup> code hopping devices, Serial EEPROMs, microperipherals, nonvolatile memory and analog products. In addition, Microchip's quality system for the design and manufacture of development systems is ISO 9001:2000 certified.*



# MCP6V01 THERMOCOUPLE AUTO-ZEROED REFERENCE DESIGN

## Table of Contents

<b>Preface</b> .....	<b>1</b>
Introduction.....	1
Document Layout .....	1
Conventions Used in this Guide .....	2
Recommended Reading.....	3
The Microchip Web Site .....	3
Customer Support .....	4
Document Revision History .....	4
<b>Chapter 1. Product Overview</b>	
1.1 Introduction .....	5
1.2 MCP6V01 Thermocouple Auto-Zeroed Reference Design Kit Contents .....	5
1.3 MCP6V01 Thermocouple Auto-Zeroed Reference Design Description .....	6
<b>Chapter 2. Installation and Operation</b>	
2.1 Introduction .....	11
2.2 Required Tool .....	11
2.3 MCP6V01 Thermocouple Auto-Zeroed Reference Design Setup .....	11
2.4 MCP6V01 Thermocouple Auto-Zeroed Reference Design Operation .....	12
<b>Appendix A. Schematic and Layout</b>	
A.1 Introduction .....	17
A.2 Board - Schematic .....	18
A.3 Board - Top Silk Layer .....	19
A.4 Board - Top Metal Layer .....	19
A.5 Board - Metal Layer 2 .....	20
A.6 Board - Metal Layer 3 .....	20
A.7 Board - Bottom Silk Layer (Bottom View) .....	21
A.8 Board - Bottom Layer .....	21
<b>Appendix B. Bill Of Materials (BOM)</b>	
<b>Worldwide Sales and Service</b> .....	<b>26</b>

# MCP6V01 Thermocouple Auto-Zeroed Reference Design

---

---

NOTES:



**MICROCHIP**

# MCP6V01 THERMOCOUPLE AUTO-ZEROED REFERENCE DESIGN

## Preface

### NOTICE TO CUSTOMERS

All documentation becomes dated, and this manual is no exception. Microchip tools and documentation are constantly evolving to meet customer needs, so some actual dialogs and/or tool descriptions may differ from those in this document. Please refer to our web site ([www.microchip.com](http://www.microchip.com)) to obtain the latest documentation available.

Documents are identified with a “DS” number. This number is located on the bottom of each page, in front of the page number. The numbering convention for the DS number is “DSXXXXA”, where “XXXX” is the document number and “A” is the revision level of the document.

For the most up-to-date information on development tools, see the MPLAB® IDE on-line help. Select the Help menu, and then Topics to open a list of available on-line help files.

## INTRODUCTION

This chapter contains general information that will be useful to know before using the MCP6V01 Thermocouple Auto-Zeroed Reference Design. Items discussed in this chapter include:

- Document Layout
- Conventions Used in this Guide
- Recommended Reading
- The Microchip Web Site
- Customer Support
- Document Revision History

## DOCUMENT LAYOUT

This document describes how to use the MCP6V01 Thermocouple Auto-Zeroed Reference Design as a development tool to emulate and debug firmware on a target board. The manual layout is as follows:

- **Chapter 1. “Product Overview”** - Provides the important information about the MCP6V01 Thermocouple Auto-Zeroed Reference Design.
- **Chapter 2. “Installation and Operation”** – Covers the installation and operation of the MCP6V01 Thermocouple Auto-Zeroed Reference Design. It shows how to set up the board, and demonstrates how to verify the operation.
- **Appendix A. “Schematic and Layout”** – Shows the schematic and board layouts for the MCP6V01 Thermocouple Auto-Zeroed Reference Design.
- **Appendix B. “Bill Of Materials (BOM)”** – Lists the parts used to build the MCP6V01 Thermocouple Auto-Zeroed Reference Design.

# MCP6V01 Thermocouple Auto-Zeroed Reference Design

## CONVENTIONS USED IN THIS GUIDE

This manual uses the following documentation conventions:

### DOCUMENTATION CONVENTIONS

Description	Represents	Examples
<b>Arial font:</b>		
Italic characters	Referenced books	<i>MPLAB<sup>®</sup> IDE User's Guide</i>
	Emphasized text	...is the <i>only</i> compiler...
Initial caps	A window	the Output window
	A dialog	the Settings dialog
	A menu selection	select Enable Programmer
Quotes	A field name in a window or dialog	"Save project before build"
Underlined, italic text with right angle bracket	A menu path	<u><i>File&gt;Save</i></u>
Bold characters	A dialog button	Click <b>OK</b>
	A tab	Click the <b>Power</b> tab
N'Rnnnn	A number in verilog format, where N is the total number of digits, R is the radix and n is a digit.	4'b0010, 2'hF1
Text in angle brackets < >	A key on the keyboard	Press <Enter>, <F1>
<b>Courier New font:</b>		
Plain Courier New	Sample source code	#define START
	Filenames	autoexec.bat
	File paths	c:\mcc18\h
	Keywords	_asm, _endasm, static
	Command-line options	-Opa+, -Opa-
	Bit values	0, 1
	Constants	0xFF, 'A'
Italic Courier New	A variable argument	<i>file.o</i> , where <i>file</i> can be any valid filename
Square brackets [ ]	Optional arguments	mcc18 [options] <i>file</i> [options]
Curly brackets and pipe character: {   }	Choice of mutually exclusive arguments; an OR selection	errorlevel {0 1}
Ellipses...	Replaces repeated text	var_name [, var_name...]
	Represents code supplied by user	void main (void) { ... }

## RECOMMENDED READING

This user's guide describes how to use MCP6V01 Thermocouple Auto-Zeroed Reference Design. Other useful documents are listed below. The following Microchip documents are available and recommended as supplemental reference resources.

**MCP6V01/2/3/6/7/8 Data Sheet, “Auto-Zeroed Op Amps” (DS51738)**

This data sheet provides detailed information regarding the MCP6V0X Op Amps.

**MCP6001/2/4 Data Sheet, “1 MHz, Low-Power Op Amps” (DS21733)**

This data sheet provides detailed information regarding the MCP600X Op Amps.

**MCP1525/41 Data Sheet, “2.5V and 4.096V Voltage References” (DS21653)**

This data sheet provides detailed information on the MCP15XX Voltage References.

**MCP9800/1/2/3 Data Sheet, “2-Wire High-Accuracy Temperature Sensor” (DS21909)**

This data sheet provides detailed information regarding the MCP980X Temperature Sensors.

**PIC18F2455/2550/4455/4550 Data Sheet, “28/40/44-Pin, High-Performance, Enhanced Flash, USB Microcontrollers with nanoWatt Technology” (DS39632)**

This data sheet provides detailed information regarding the PIC18F2455/2550/4455/4550 Microcontrollers.

**AN679, “Temperature Sensing Technologies” (DS00679)**

This application note covers the most popular temperature sensor technologies and helps determine the most appropriate sensor for an application.

**AN684, “Single Supply Temperature Sensing with Thermocouples” (DS00684)**

This application note focuses on thermocouple circuit solutions. It builds from signal conditioning components to complete application circuits.

**AN699, “Anti-Aliasing, Analog Filters for Data Acquisition Systems” (DS00699)**

A tutorial on active analog filters and their most common applications.

**“Signal Chain Design Guide” (DS21825)**

## THE MICROCHIP WEB SITE

Microchip provides online support via our web site at [www.microchip.com](http://www.microchip.com). This web site is used as a means to make files and information easily available to customers. Accessible by using your favorite Internet browser, the web site contains the following information:

- **Product Support** – Data sheets and errata, application notes and sample programs, design resources, user's guides and hardware support documents, latest software releases and archived software
- **General Technical Support** – Frequently Asked Questions (FAQs), technical support requests, online discussion groups, Microchip consultant program member listing
- **Business of Microchip** – Product selector and ordering guides, latest Microchip press releases, listing of seminars and events, listings of Microchip sales offices, distributors and factory representatives

# MCP6V01 Thermocouple Auto-Zeroed Reference Design

---

---

## CUSTOMER SUPPORT

Users of Microchip products can receive assistance through several channels:

- Distributor or Representative
- Local Sales Office
- Field Application Engineer (FAE)
- Technical Support

Customers should contact their distributor, representative or field application engineer (FAE) for support. Local sales offices are also available to help customers. A listing of sales offices and locations is included in the back of this document.

Technical support is available through the web site at: <http://support.microchip.com>

## DOCUMENT REVISION HISTORY

### **Revision B (December 2008)**

- Updated the Bottom Metal Layer print.
- Updated Product Review.

### **Revision A (May 2008)**

- Initial Release of this Document.





# MCP6V01 THERMOCOUPLE AUTO-ZEROED REFERENCE DESIGN

## Chapter 1. Product Overview

### 1.1 INTRODUCTION

The MCP6V01 Thermocouple Auto-Zeroed Reference Design is described by the following:

- Assembly # : 114-00169
- Order # : MCP6V01RD-TCPL
- Name: MCP6V01 Thermocouple Auto-Zeroed Reference Design Board

Items discussed in this chapter include:

- MCP6V01 Thermocouple Auto-Zeroed Reference Design Board Kit Contents
- MCP6V01 Thermocouple Auto-Zeroed Reference Design Board Description
- Associated Tools

### 1.2 MCP6V01 THERMOCOUPLE AUTO-ZEROED REFERENCE DESIGN KIT CONTENTS

- MCP6V01 Thermocouple Auto-Zeroed Reference Design (102-00169)
- Important “Read First” Information
- Accessory Bag - Contains a K-type thermocouple and an USB cable
- Analog and Interface Products Demonstration Boards CD-ROM (DS21912) includes:
  - MCP6V01 Thermocouple Auto-Zeroed Reference Design (D51738)
  - Thermal Management Software
  - Firmware for PIC18F2550



**FIGURE 1-1:** MCP6V01 Thermocouple Auto-Zeroed Reference Design Kit.

# MCP6V01 Thermocouple Auto-Zeroed Reference Design

---

## 1.3 MCP6V01 THERMOCOUPLE AUTO-ZEROED REFERENCE DESIGN DESCRIPTION

### 1.3.1 Function Block Diagram Description

The MCP6V01 Thermocouple Auto-Zeroed Reference Design demonstrates how to measure electromotive force (EMF) voltage at the cold junction of the thermocouple in order to accurately measure temperature at the hot junction. This can be done by using the MCP6V01 auto-zeroed op amp because of its ultra low offset voltage ( $V_{OS}$ ) and high common mode rejection ratio (CMRR).

- The difference amplifier is implemented using the MCP6V01 and 0.1% tolerance resistors. It amplifies the EMF voltage at the cold junction of the thermocouple.
- The MCP9800 senses temperature at the type K thermocouple's connector. It should be located as close as possible to the connector on the PCB. This measurement is used to perform cold junction compensation for the thermocouple measurement.
- The MCP1541 provides a  $V_{REF}$  (4.1V) to the internal 10-Bit ADC of the PIC18F2550 and sets the reference voltage for the difference amplifier.
- The  $CV_{REF}$  is the internal comparator voltage reference of PIC18F2550, which is a 16-tap resistor ladder network that provides a selectable reference voltage. The MCP6001 buffer amplifier eliminates the voltage reference output impedance problem and produces the voltage  $V_{SHIFT}$ .
- The 2<sup>nd</sup> order RC low-pass filter that is implemented in this circuit can remove the high frequency noise and aliasing at the ADC input. The ADC of PIC18F2550 completes the analog-to-digital conversion. The data will be transferred to the PC using the USB interface.
- The Thermal Management Software on PC is used to perform data display to show the real-time temperature and apply cold junction compensation and data linearization to determine the actual temperature of the thermocouple's hot junction (weld bead).

Figure 1-2 shows the function block diagram of the MCP6V01 Thermocouple Auto-Zeroed Reference Design.

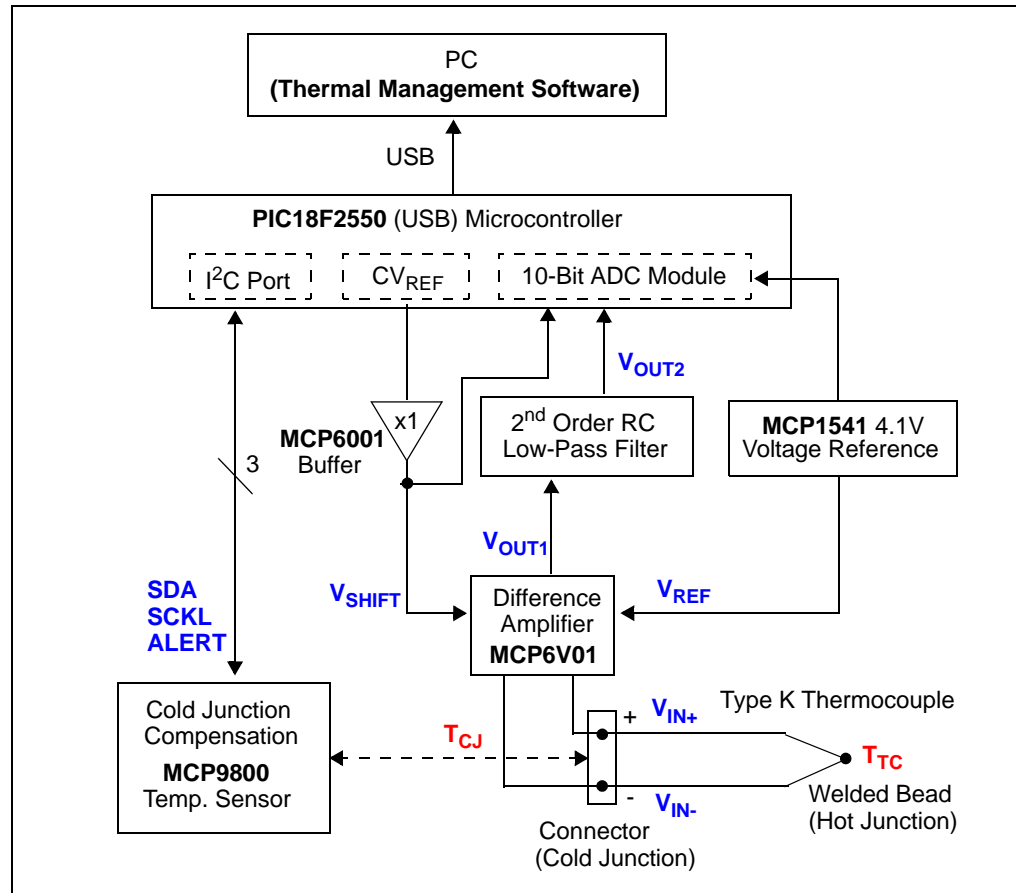

**FIGURE 1-2:** Function Block Diagram of the MCP6V01 Thermocouple Auto-Zeroed Reference Design.

# MCP6V01 Thermocouple Auto-Zeroed Reference Design

## 1.3.2 Analog Sensing Circuit Diagram Description

- Difference Amplifier
  - Uses a MCP6V01 auto-zeroed op amp (U5)
  - Two 0.1% tolerance gain resistors (R8 and R11)
  - Two 0.1% tolerance input resistors for shifting  $V_{OUT1}$  (R9 and R10)
  - Two 0.1% tolerance input resistors for the thermocouple output (R6 and R7)
- Buffer Amplifier
  - Uses a MCP6001 standard op amp (U4)
  - Outputs  $V_{SHIFT}$  which shifts  $V_{OUT1}$  by 16 different values
  - Sends  $V_{SHIFT}$  back to PIC's internal ADC to make calculated result more accurate
- 2nd Order RC Low-Pass Filter
  - Fast enough to quick changes in temperature
  - Double pole for anti-aliasing and removing high-frequency noise
  - No DC offset and simple architecture

Figure 1-3 shows the analog sensing circuit diagram of MCP6V01 Thermocouple Auto-Zeroed Reference Design.

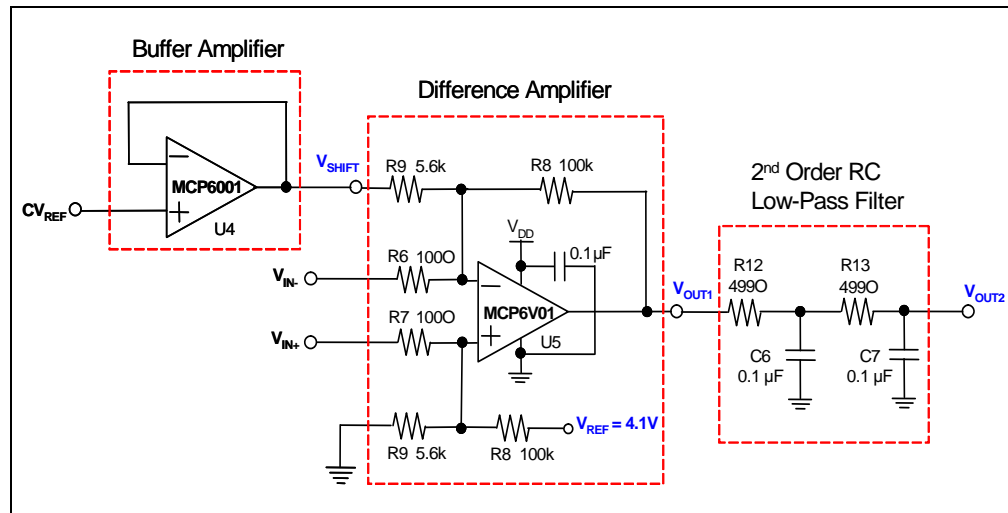

**FIGURE 1-3:** Analog Sensing Circuit Diagram of the MCP6V01 Thermocouple Auto-Zeroed Reference Design.

## 1.3.3 $V_{SHIFT}$ Operation Description

$CV_{REF}$  produces  $V_{SHIFT}$  through the buffer amplifier.  $V_{SHIFT}$  is brought back to the PIC18F2550 so that it can be sampled by the ADC, then used to adjust the measured  $V_{OUT1}$ . This makes the  $V_{SHIFT}$  values accurate to the 10-Bit ADC's capability. The values within each range also have a resolution of 10 bits. Thus, this gives 14 bits of resolution in total.

- 14-Bit Resolution, 10-Bit ADC
  - PIC18F2550's  $CV_{REF}$  (16 levels) subdivides input ranges
  - PIC18F2550's internal 10-Bit ADC converts result and calibrates  $CV_{REF}$
  - The firmware automatically searches for correct  $CV_{REF}$  value
- This solution minimizes cost by using resources internal to the PIC to achieve reasonable resolution without an external ADC. Further savings could be achieved by using a voltage reference internal to the PIC instead of the external MCP1541.

**Note:**  $V_{OUT1}$ ,  $V_{SHIFT1}$  and  $V_{IN+} - V_{IN-}$  are not drawn to scale. This is a conceptual diagram only.

Figure 1-4 shows the conceptual diagram of the  $V_{SHIFT}$  operation.

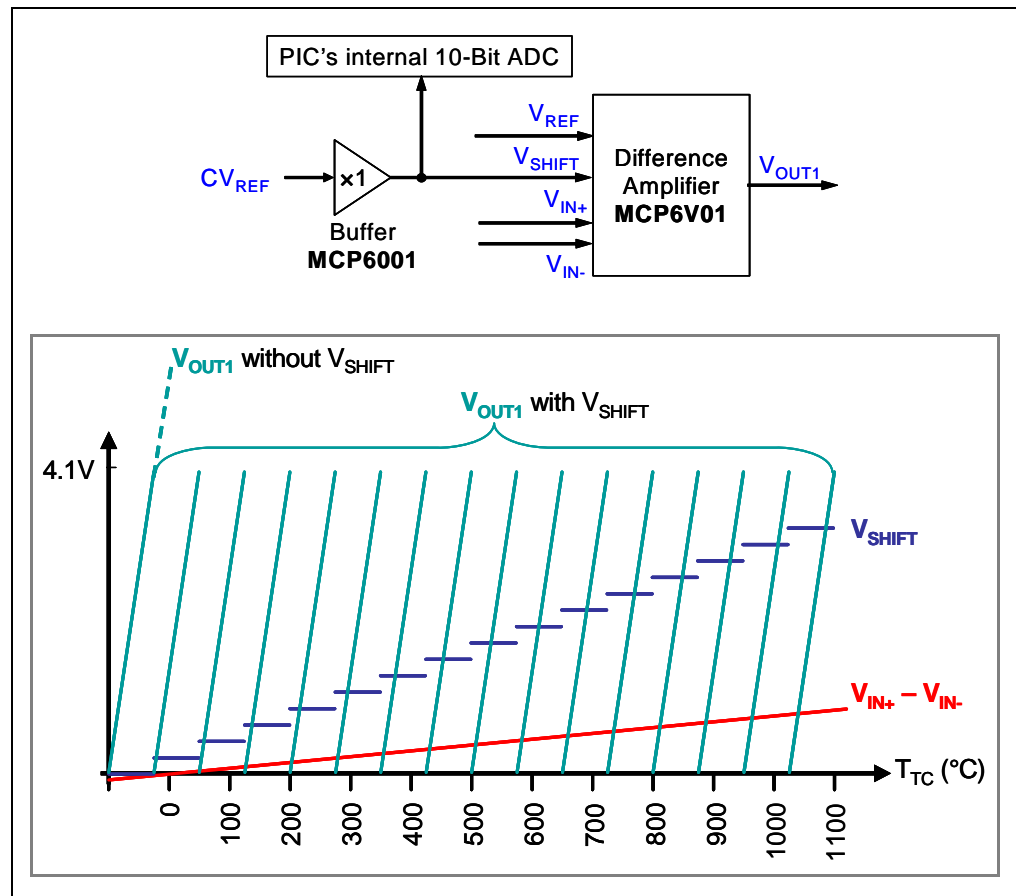

**FIGURE 1-4:**  $V_{SHIFT}$  Operation Conceptual Diagram.

# MCP6V01 Thermocouple Auto-Zeroed Reference Design

---

The MCP6V01 Thermocouple Auto-Zeroed Reference Design has the following features:

- Uses a MCP6V01 difference amplifier as an analog sensor conditioning circuit
- Uses the K-type thermocouple to sense temperature
- Temperature range is from -100°C to +1000°C
- Uses the MCP9800 Temperature Sensor for cold junction compensation
- Uses the USB interface to transfer data to PC
- 14-Bit Resolution, 10-Bit ADC
- Test points for bench work

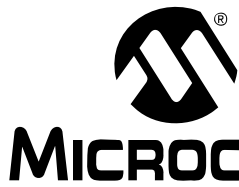

# MCP6V01 THERMOCOUPLE AUTO-ZEROED REFERENCE DESIGN

## Chapter 2. Installation and Operation

### 2.1 INTRODUCTION

This chapter shows how to set up the MCP6V01 Thermocouple Auto-Zeroed Reference Design and explores the operation of a temperature measurement application.

Items discussed in this chapter include:

- Required Tools
- MCP6V01 Thermocouple Auto-Zeroed Reference Design Setup
- MCP6V01 Thermocouple Auto-Zeroed Reference Design Operation

### 2.2 REQUIRED TOOL

- The Personal Computer (PC) shown in Figure 1-2 needs to run on Windows® 98 SE or later. It provides a convenient interface for the user, communicates with the boards, and provides power through the USB connection.

### 2.3 MCP6V01 THERMOCOUPLE AUTO-ZEROED REFERENCE DESIGN SETUP

1. Connect the type K thermocouple and the USB cable to the MCP6V01 Thermocouple Auto-Zeroed Reference Design.

An exploded view is shown in the Figure 2-1.

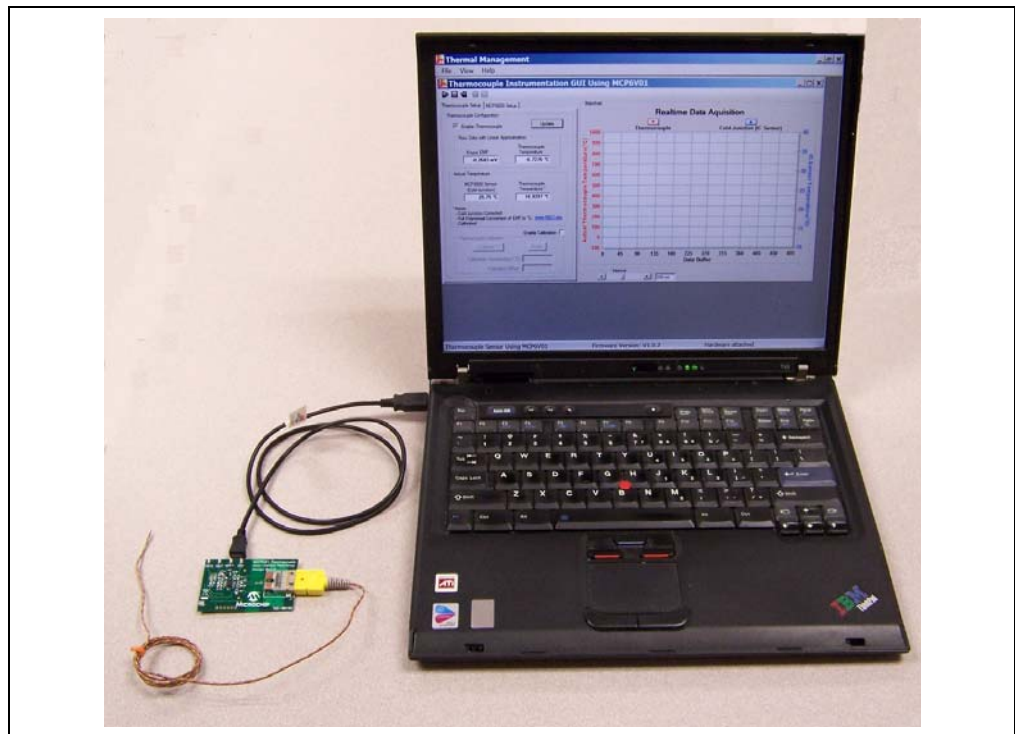

**FIGURE 2-1:** MCP6V01 Thermocouple Auto-Zeroed Reference Design Setup.

# MCP6V01 Thermocouple Auto-Zeroed Reference Design

## 2.4 MCP6V01 THERMOCOUPLE AUTO-ZEROED REFERENCE DESIGN OPERATION

1. Start the Thermal Management Software on the PC.

If the hardware is connected properly, the software will recognize the hardware and this is confirmed by showing the Thermocouple Instrumentation GUI Using MCP6V01 panel, as indicated in Figure 2-2. Otherwise, the software will show the Hardware Not Detected message box, as indicated in Figure 2-3.

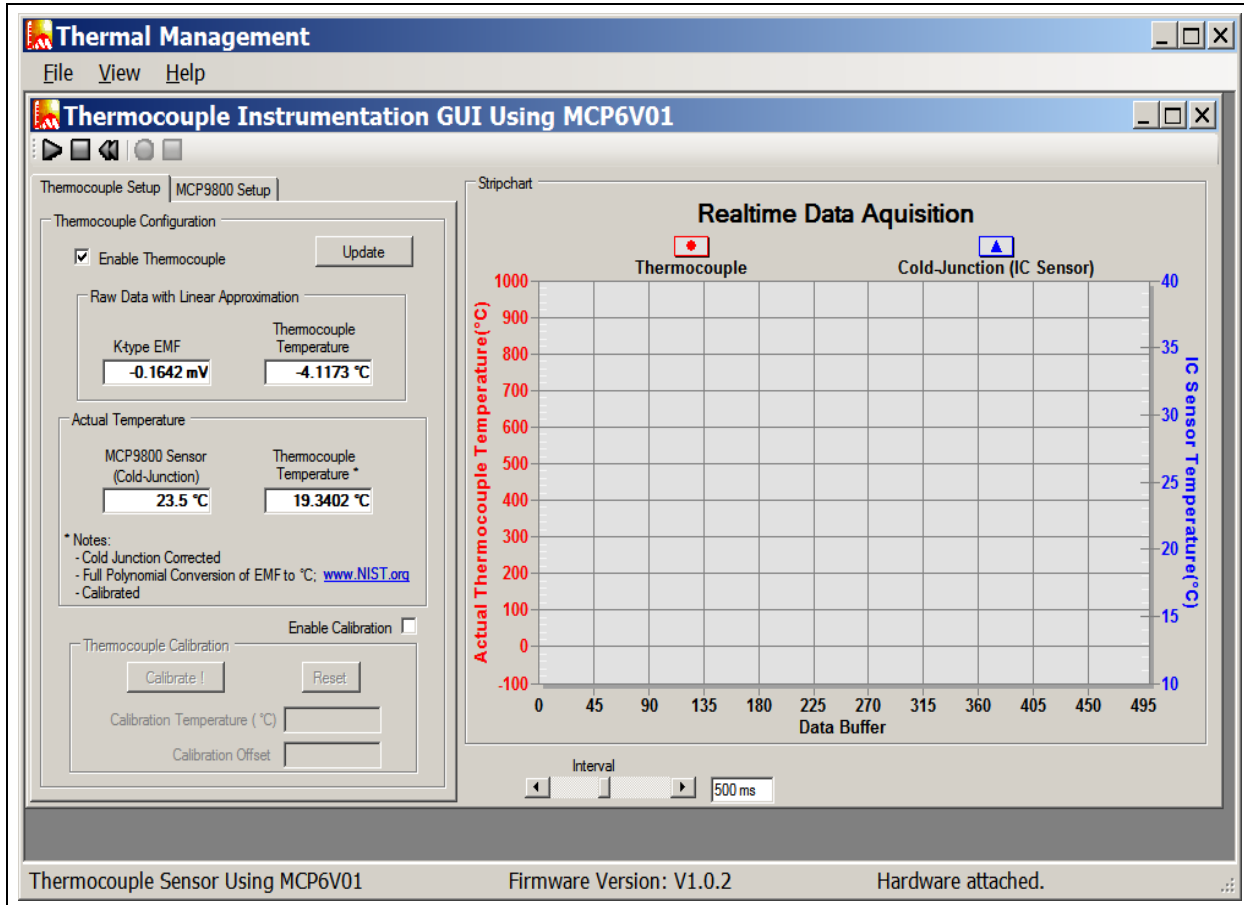

**FIGURE 2-2:** Thermocouple Instrumentation GUI Using MCP6V01.

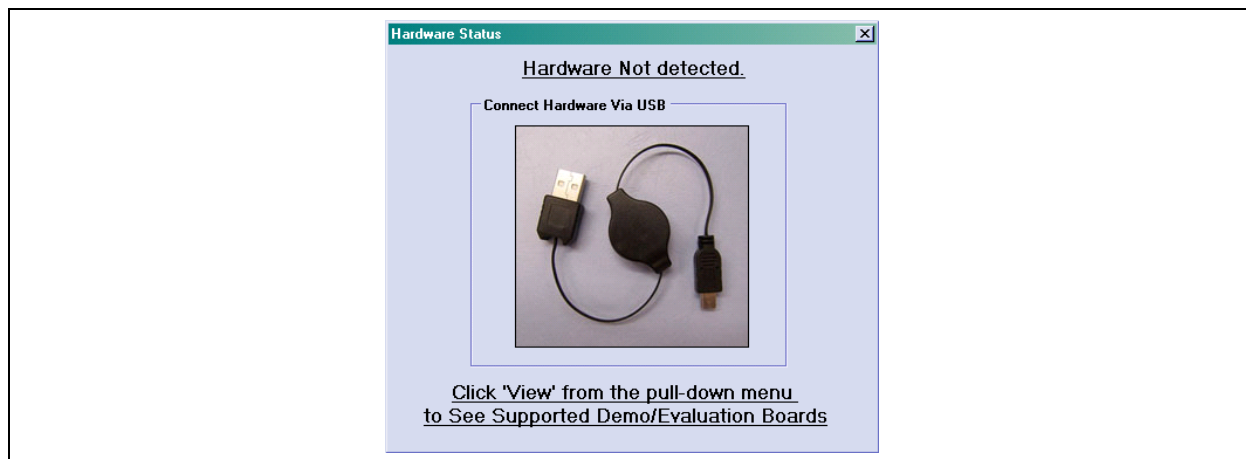
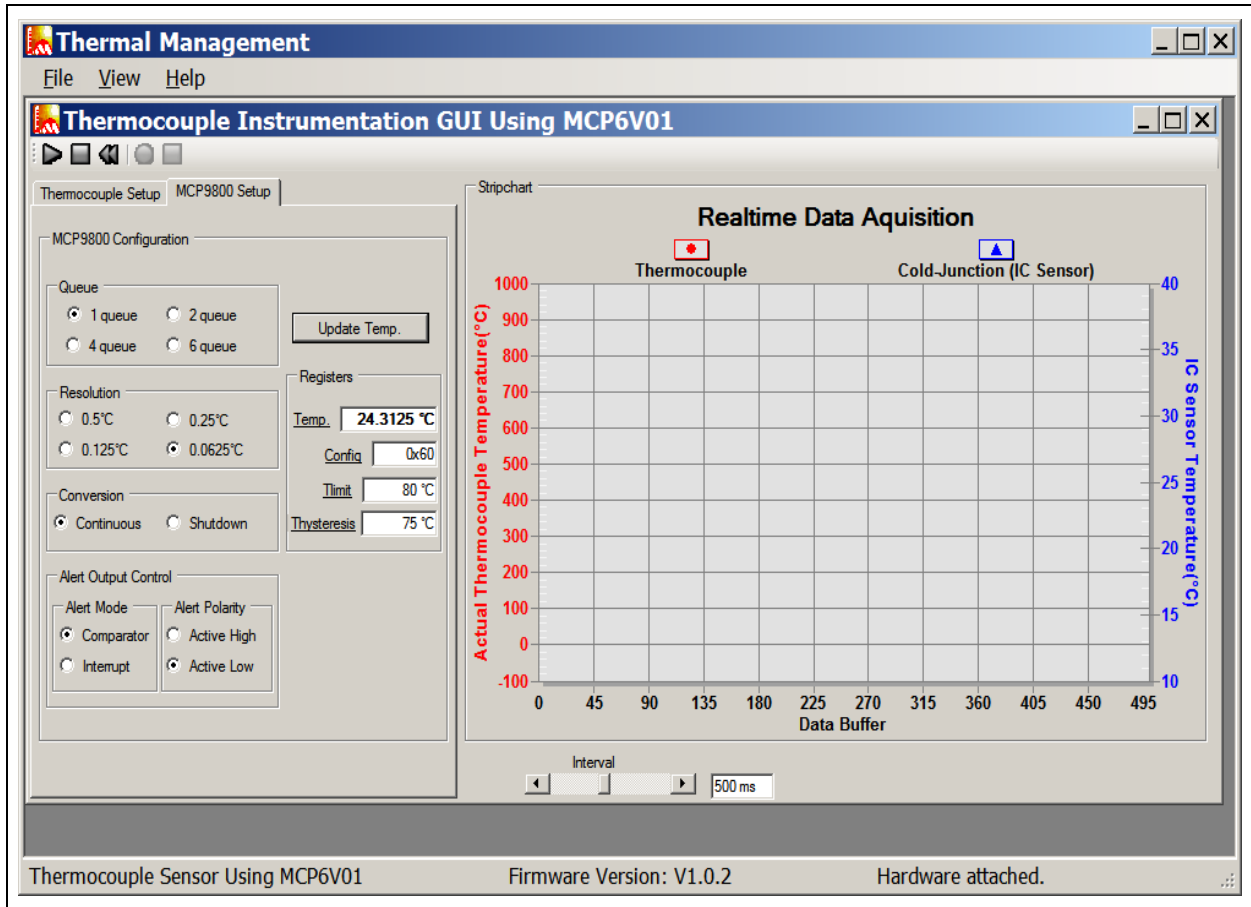

**FIGURE 2-3:** Hardware Not Detected Message Box.



## 2.4.1 Set Up the MCP9800 Temperature Sensor Configuration

1. Click the **MCP9800 Setup** tab.
2. The **MCP9800 Configuration** can be modified from the default values.
3. Click the **Update Temp.** button to complete the modifications.

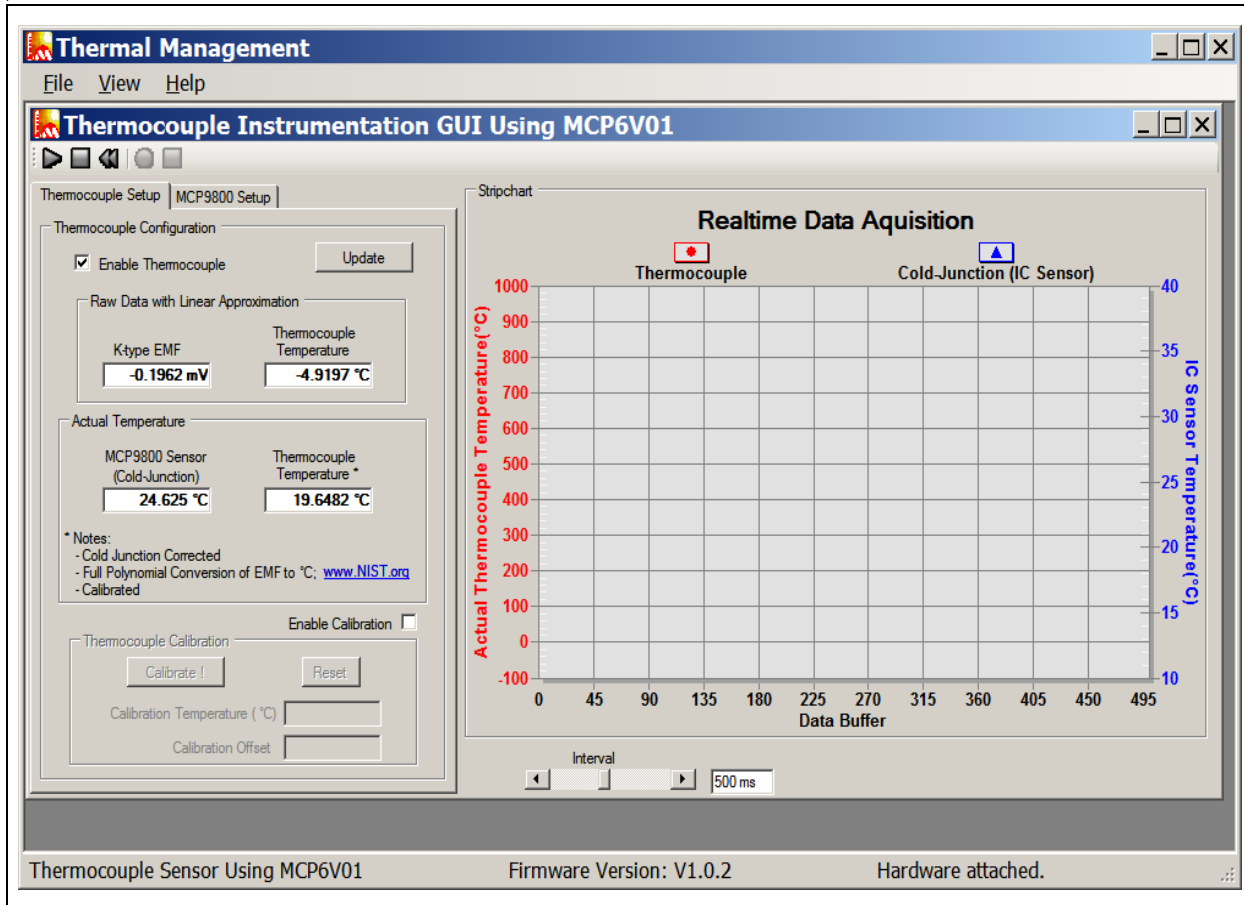

**FIGURE 2-4:** MCP9800 Setup.

# MCP6V01 Thermocouple Auto-Zeroed Reference Design

## 2.4.2 Set Up the Thermocouple Configuration

1. Click the **Thermocouple Setup** tab.
2. **Enable thermocouple** is selected as default. **Enable Calibration** also can be selected.
3. Click the **Update** button to complete the setup.



**FIGURE 2-5:** Thermocouple setup.

## 2.4.3 Customize the Realtime Data Acquisition

1. Double click on the region of the stipchart to customize the Realtime Data Acquisition.

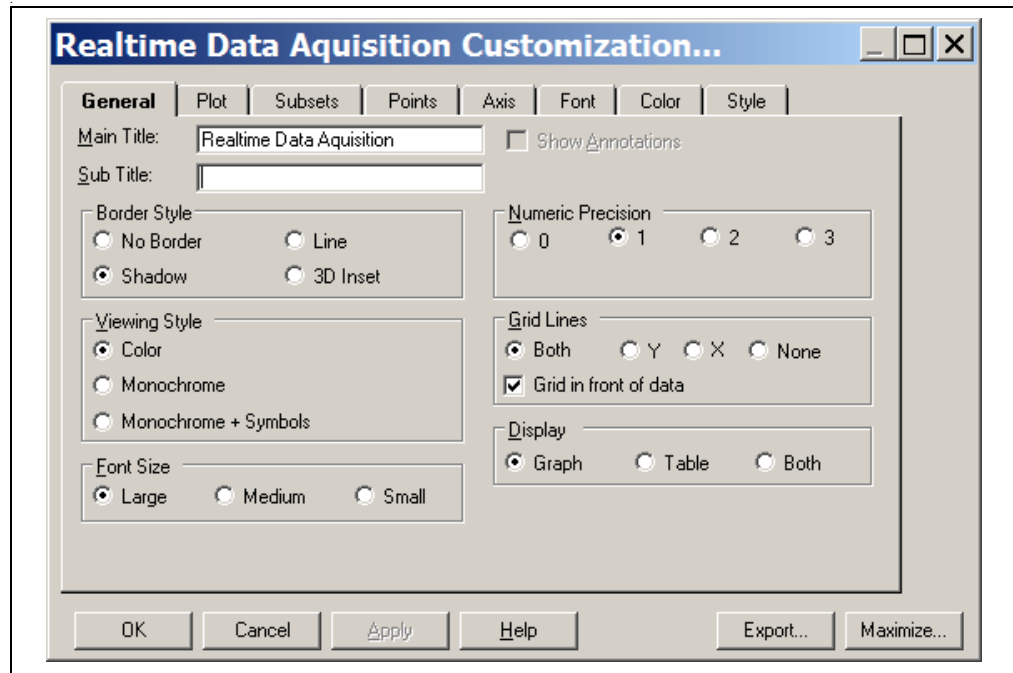
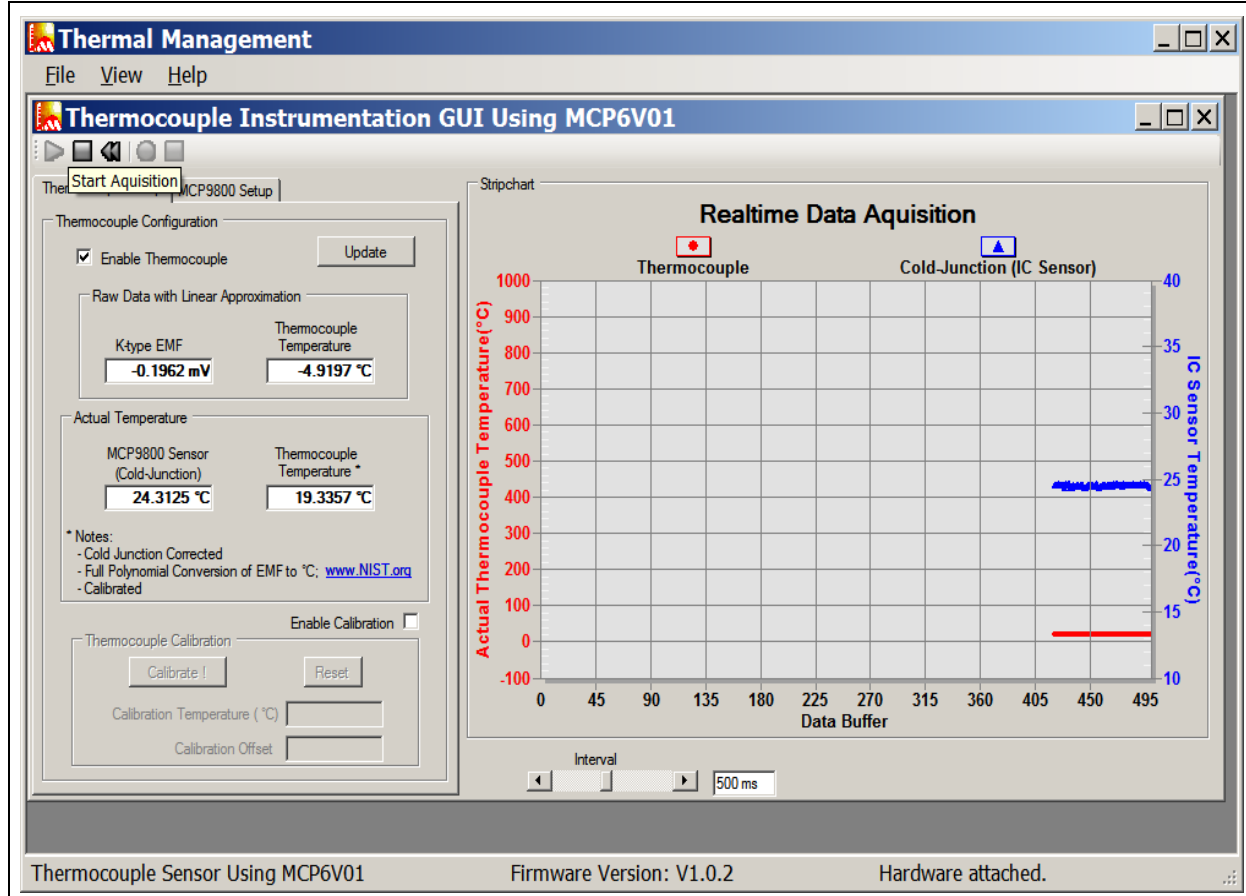

**FIGURE 2-6:** Realtime Data Acquisition Customization.

# MCP6V01 Thermocouple Auto-Zeroed Reference Design

## 2.4.3.1 START THE REALTIME DATA AQUISION

1. Click the **PLAY** button to start the Realtime Data Aquision.



**FIGURE 2-7:** Start Realtime Data Acquisition.



# MCP6V01 THERMOCOUPLE AUTO-ZEROED REFERENCE DESIGN

---

---

## Appendix A. Schematic and Layout

---

---

### A.1 INTRODUCTION

This appendix contains the following schematics and layouts for the MCP6V01 Thermocouple Auto-Zeroed Reference Design:

- Board – Schematic
- Board – Top Silk Layer
- Board – Top Metal Layer
- Board – Metal Layer 2
- Board – Metal Layer 3
- Board – Bottom Silk Layer
- Board – Bottom Metal Layer

# MCP6V01 Thermocouple Auto-Zeroed Reference Design

## A.2 BOARD - SCHEMATIC

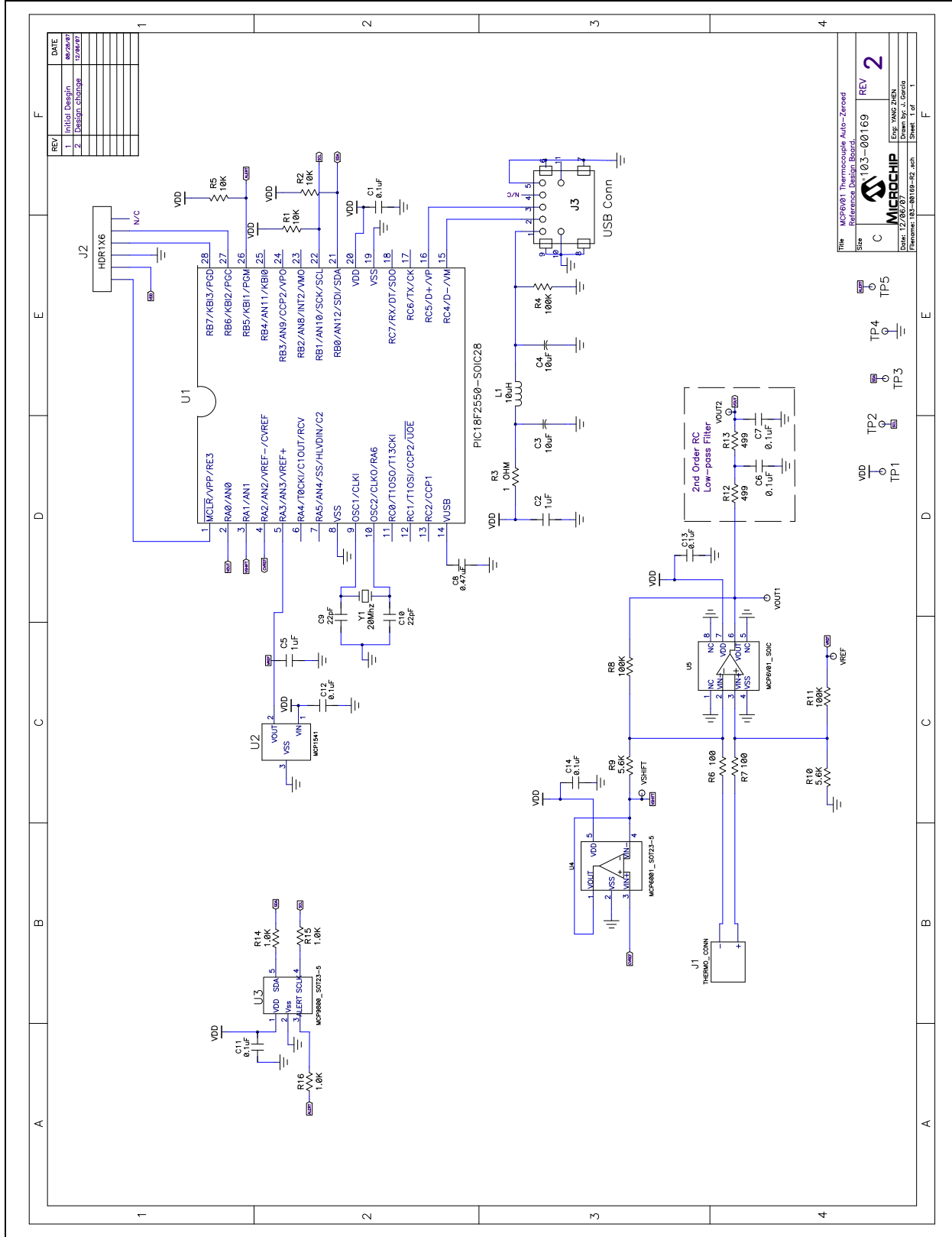

A.3 BOARD - TOP SILK LAYER

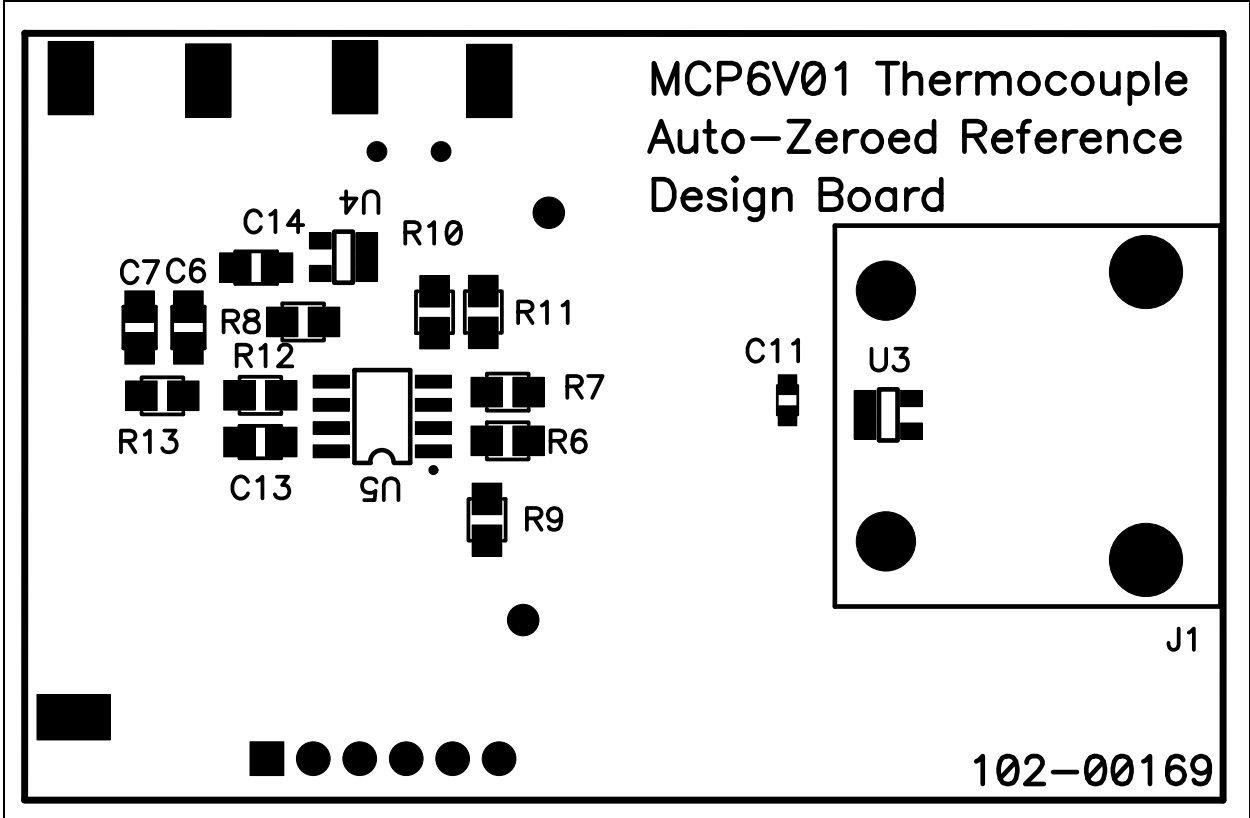

A.4 BOARD - TOP METAL LAYER

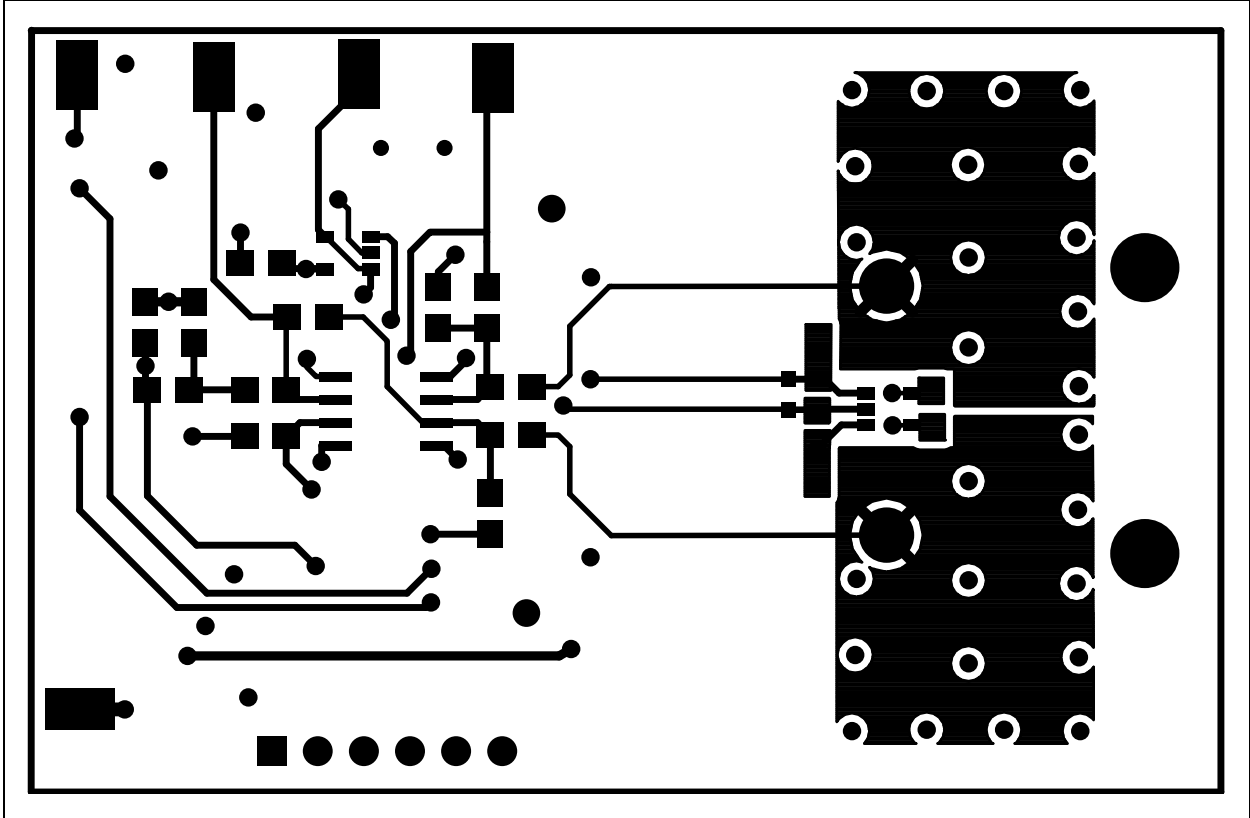

# MCP6V01 Thermocouple Auto-Zeroed Reference Design

## A.5 BOARD - METAL LAYER 2

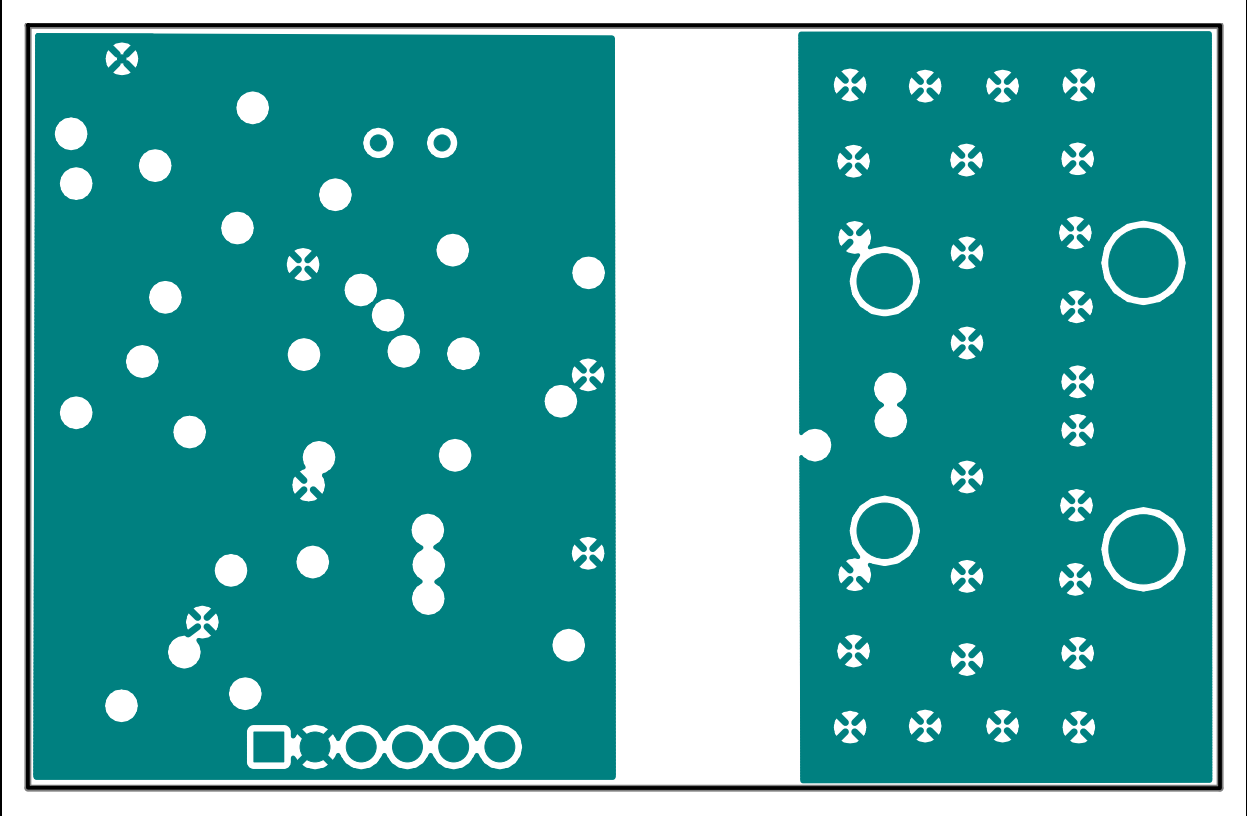

## A.6 BOARD - METAL LAYER 3

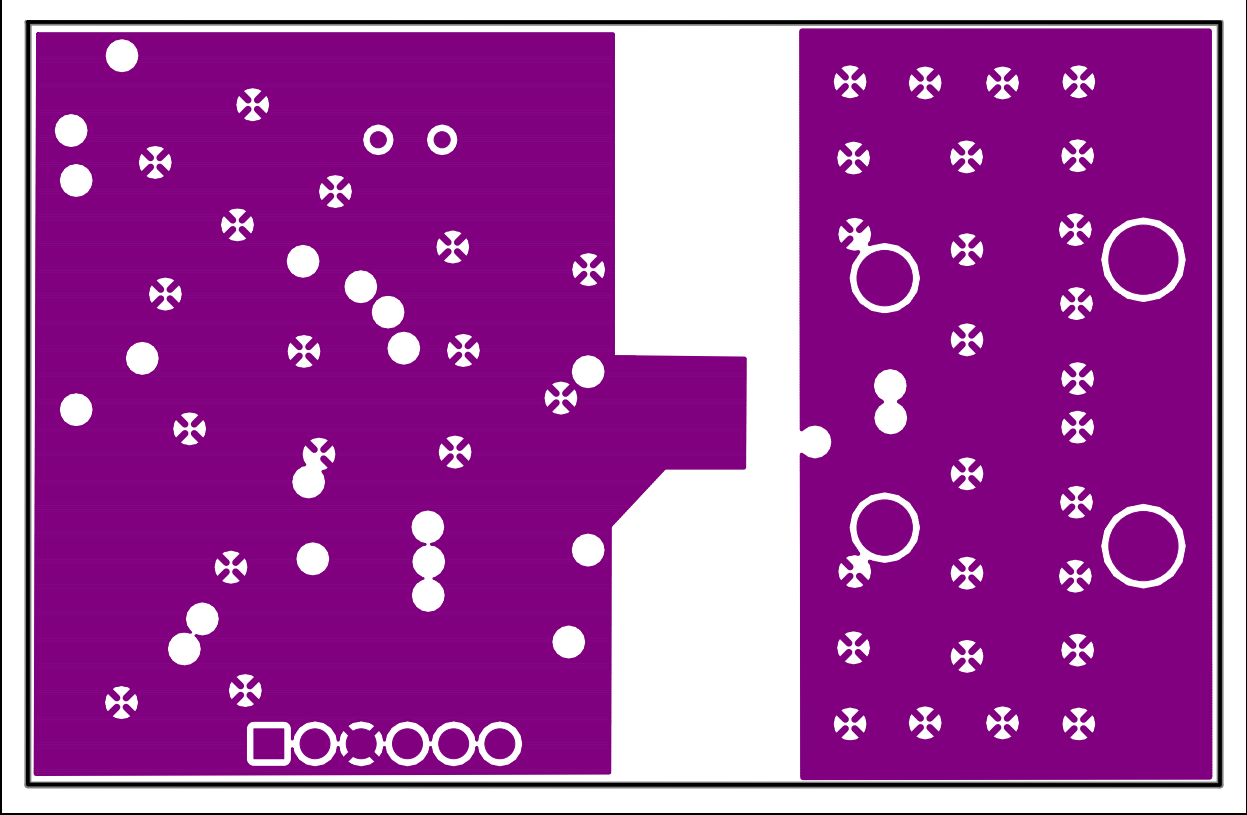



## A.7 BOARD - BOTTOM SILK LAYER (BOTTOM VIEW)

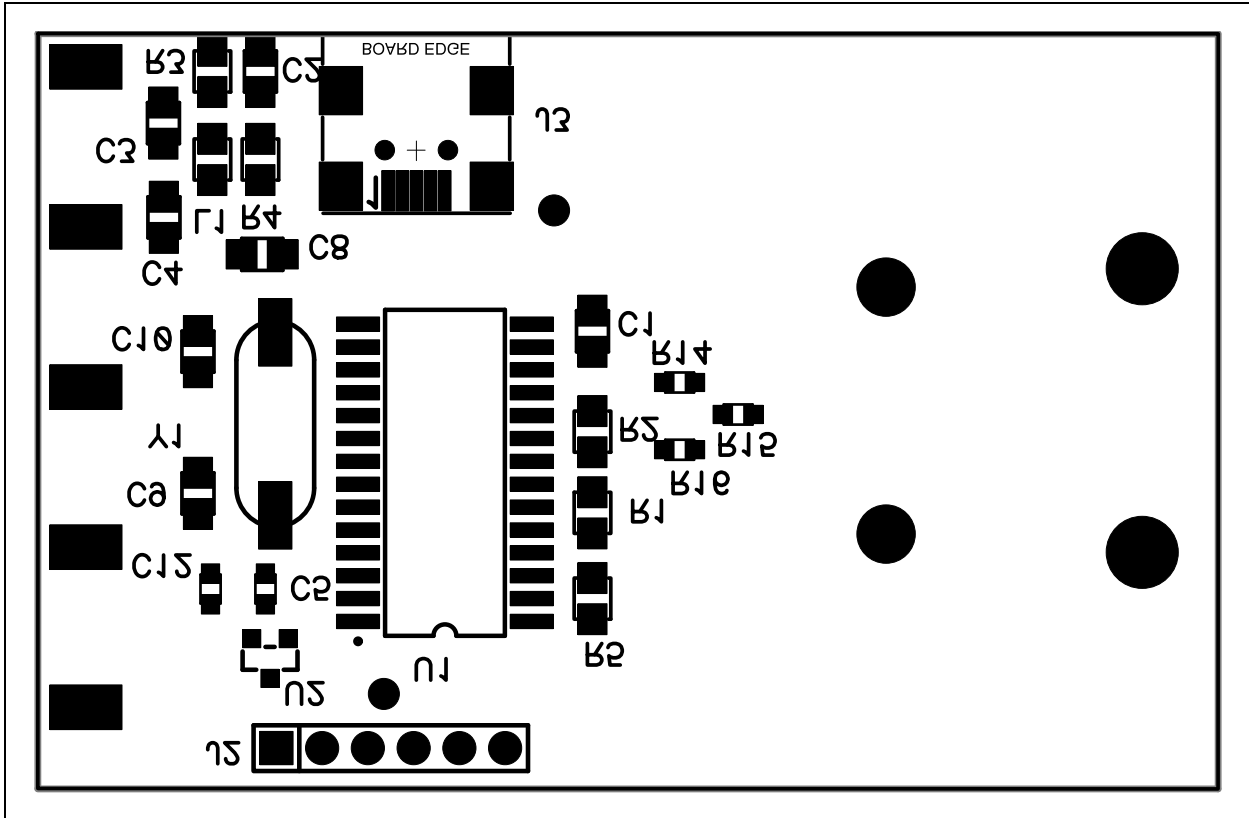

## A.8 BOARD - BOTTOM METAL LAYER

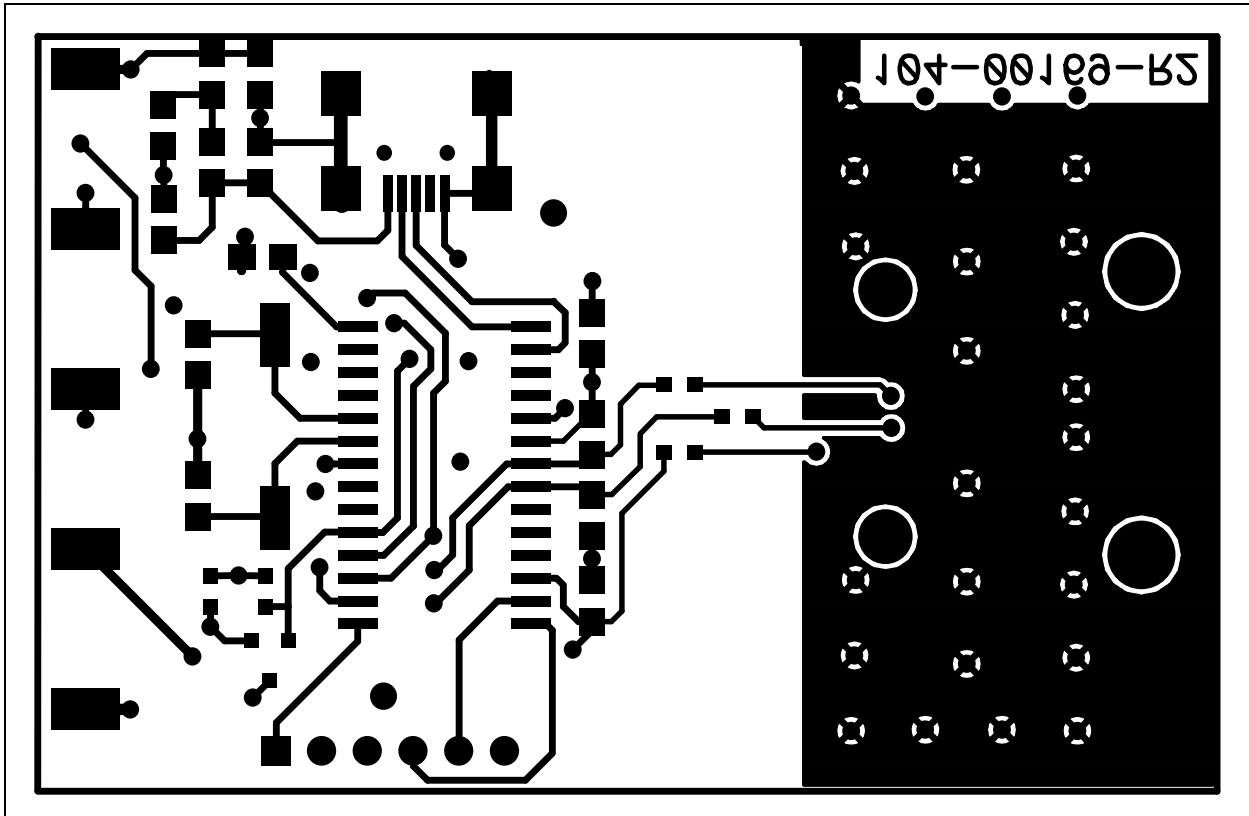

# MCP6V01 Thermocouple Auto-Zeroed Reference Design

---

---

NOTES:



# MCP6V01 THERMOCOUPLE AUTO-ZEROED REFERENCE DESIGN

## Appendix B. Bill Of Materials (BOM)

TABLE B-1: BILL OF MATERIALS (BOM)

Qty	Reference	Description	Manufacturer	Part Number
5	C1, C6, C7, C13, C14	CAP .1UF 25V CERAMIC X7R 0805	Panasonic® - ECG	ECJ-2VB1E104K
1	C2	CAP 1.0UF 25V CERAMIC F 0805	Panasonic - ECG	ECJ-2FF1E105Z
2	C3, C4	CAP CER 10UF 16V Y5V 0805	Murata Electronics® North America	GRM21BF51C106ZE15L
1	C5	CAP 1.0UF 25V CERAMIC F 0603	Panasonic - ECG	ECJ-1VF1E105Z
1	C8	CAP .47UF 25V CERAMIC Y5V 0805	Panasonic - ECG	ECJ-2YF1E474Z
2	C9, C10	CAP 22PF 50V CERM CHIP 0805 SMD	Panasonic - ECG	ECJ-2VC1H220J
2	C11, C12	CAP .1UF 25V CERAMIC X7R 0603	Panasonic - ECG	ECJ-1VB1E104K
1	J1	Circuit Board Thermocouple Connectors, Standard	OMEGA	PCC-SMP-K-100
1	J2	HEADER 1X6 DO NOT POPULATE	—	—
1	J3	CONN RECEPT MINI USB2.0 5POS	Hirose Electronic Co Ltd	UX60-MB-5ST
1	L1	INDUCTOR 10UH 100MA 0805	Murata Electronics North America	LQM21FN100M70L
1	PCB	RoHS Compliant Bare PCB, Thermocouple Auto-Zero RD Board	—	104-00169
3	R1, R2, R5	RES 10.0K OHM 1/8W 1% 0805 SMD	Panasonic - ECG	ERJ-6ENF1002V
1	R3	RES 1.0 OHM 1/8W 1% 0805 SMD	Panasonic - ECG	ERJ-6RQF1R0V
1	R4	RES 100K OHM 1/8W 1% 0805 SMD	Panasonic - ECG	ERJ-6ENF1003V
2	R6, R7	RES 100 OHM 1/10W 0.1% 0805 SMD	Panasonic - ECG	ERA-6AEB101V
2	R8, R11	RES 100K OHM 1/10W 0.1% 0805 SMD	Panasonic - ECG	ERA-6AEB104V
2	R9, R10	RES 5.6K OHM 1/10W 0.1% 0805 SMD	Panasonic - ECG	ERA-6AEB562V
2	R12, R13	RES 499 OHM 1/8W 1% 0805 SMD	Panasonic - ECG	ERJ-6ENF4990V

**Note 1:** The components listed in this Bill of Materials are representative of the PCB assembly. The released BOM used in manufacturing uses all RoHS-compliant components.

# MCP6V01 Thermocouple Auto-Zeroed Reference Design

TABLE B-1: BILL OF MATERIALS (BOM) (CONTINUED)

Qty	Reference	Description	Manufacturer	Part Number
3	R14, R15, R16	RES 1.0K OHM 1/10W 1% 0603 SMD	Panasonic - ECG	ERJ-3EKF1001V
1	Thermocouples (5 Per Pack)	Ready-Made Insulated Thermocouples with Kapton, PFA, Glass Braid Insulation and Molded Connectors	OMEGA	5SRTC-TT-K-24-36 (5 Pcs. Per Pack)
10	TP1---TP10	TEST POINT PC COMPACT SMT	Keystone Electronics®	5016
1	U1	28/40/44-Pin, High-Performance, Enhanced Flash, USB Microcontrollers with nanoWatt Technology	Microchip Technology Inc.	PIC18F2550-I/SO
1	U2	4.096V Voltage Reference	Microchip Technology Inc.	MCP1541T-I/TT
1	U3	Memory Module Digital Temperature Sensor, MCP9800	Microchip Technology Inc.	MCP9800A0T-M/OTG
1	U4	MCP6001, SOT-23-5	Microchip Technology Inc.	MCP6001T-I/OT
1	U5	MCP60V1, SOIC-8	Microchip Technology Inc.	MCP6V01T-E/SN
1	Y1	CRYSTAL 20.0000 MHZ SERIES SMT	CTS-Frequency Controls	ATS200SM

**Note 1:** The components listed in this Bill of Materials are representative of the PCB assembly. The released BOM used in manufacturing uses all RoHS-compliant components.

# Bill Of Materials (BOM)

---

---

NOTES:



## WORLDWIDE SALES AND SERVICE

### AMERICAS

#### Corporate Office

2355 West Chandler Blvd.  
Chandler, AZ 85224-6199  
Tel: 480-792-7200  
Fax: 480-792-7277  
Technical Support:  
<http://support.microchip.com>  
Web Address:  
[www.microchip.com](http://www.microchip.com)

#### Atlanta

Duluth, GA  
Tel: 678-957-9614  
Fax: 678-957-1455

#### Boston

Westborough, MA  
Tel: 774-760-0087  
Fax: 774-760-0088

#### Chicago

Itasca, IL  
Tel: 630-285-0071  
Fax: 630-285-0075

#### Dallas

Addison, TX  
Tel: 972-818-7423  
Fax: 972-818-2924

#### Detroit

Farmington Hills, MI  
Tel: 248-538-2250  
Fax: 248-538-2260

#### Kokomo

Kokomo, IN  
Tel: 765-864-8360  
Fax: 765-864-8387

#### Los Angeles

Mission Viejo, CA  
Tel: 949-462-9523  
Fax: 949-462-9608

#### Santa Clara

Santa Clara, CA  
Tel: 408-961-6444  
Fax: 408-961-6445

#### Toronto

Mississauga, Ontario,  
Canada  
Tel: 905-673-0699  
Fax: 905-673-6509

### ASIA/PACIFIC

#### Asia Pacific Office

Suites 3707-14, 37th Floor  
Tower 6, The Gateway  
Harbour City, Kowloon  
Hong Kong  
Tel: 852-2401-1200  
Fax: 852-2401-3431

#### Australia - Sydney

Tel: 61-2-9868-6733  
Fax: 61-2-9868-6755

#### China - Beijing

Tel: 86-10-8528-2100  
Fax: 86-10-8528-2104

#### China - Chengdu

Tel: 86-28-8665-5511  
Fax: 86-28-8665-7889

#### China - Hong Kong SAR

Tel: 852-2401-1200  
Fax: 852-2401-3431

#### China - Nanjing

Tel: 86-25-8473-2460  
Fax: 86-25-8473-2470

#### China - Qingdao

Tel: 86-532-8502-7355  
Fax: 86-532-8502-7205

#### China - Shanghai

Tel: 86-21-5407-5533  
Fax: 86-21-5407-5066

#### China - Shenyang

Tel: 86-24-2334-2829  
Fax: 86-24-2334-2393

#### China - Shenzhen

Tel: 86-755-8203-2660  
Fax: 86-755-8203-1760

#### China - Wuhan

Tel: 86-27-5980-5300  
Fax: 86-27-5980-5118

#### China - Xiamen

Tel: 86-592-2388138  
Fax: 86-592-2388130

#### China - Xian

Tel: 86-29-8833-7252  
Fax: 86-29-8833-7256

#### China - Zhuhai

Tel: 86-756-3210040  
Fax: 86-756-3210049

### ASIA/PACIFIC

#### India - Bangalore

Tel: 91-80-4182-8400  
Fax: 91-80-4182-8422

#### India - New Delhi

Tel: 91-11-4160-8631  
Fax: 91-11-4160-8632

#### India - Pune

Tel: 91-20-2566-1512  
Fax: 91-20-2566-1513

#### Japan - Yokohama

Tel: 81-45-471- 6166  
Fax: 81-45-471-6122

#### Korea - Daegu

Tel: 82-53-744-4301  
Fax: 82-53-744-4302

#### Korea - Seoul

Tel: 82-2-554-7200  
Fax: 82-2-558-5932 or  
82-2-558-5934

#### Malaysia - Kuala Lumpur

Tel: 60-3-6201-9857  
Fax: 60-3-6201-9859

#### Malaysia - Penang

Tel: 60-4-227-8870  
Fax: 60-4-227-4068

#### Philippines - Manila

Tel: 63-2-634-9065  
Fax: 63-2-634-9069

#### Singapore

Tel: 65-6334-8870  
Fax: 65-6334-8850

#### Taiwan - Hsin Chu

Tel: 886-3-572-9526  
Fax: 886-3-572-6459

#### Taiwan - Kaohsiung

Tel: 886-7-536-4818  
Fax: 886-7-536-4803

#### Taiwan - Taipei

Tel: 886-2-2500-6610  
Fax: 886-2-2508-0102

#### Thailand - Bangkok

Tel: 66-2-694-1351  
Fax: 66-2-694-1350

### EUROPE

#### Austria - Wels

Tel: 43-7242-2244-39  
Fax: 43-7242-2244-393

#### Denmark - Copenhagen

Tel: 45-4450-2828  
Fax: 45-4485-2829

#### France - Paris

Tel: 33-1-69-53-63-20  
Fax: 33-1-69-30-90-79

#### Germany - Munich

Tel: 49-89-627-144-0  
Fax: 49-89-627-144-44

#### Italy - Milan

Tel: 39-0331-742611  
Fax: 39-0331-466781

#### Netherlands - Drunen

Tel: 31-416-690399  
Fax: 31-416-690340

#### Spain - Madrid

Tel: 34-91-708-08-90  
Fax: 34-91-708-08-91

#### UK - Wokingham

Tel: 44-118-921-5869  
Fax: 44-118-921-5820



## Стандарт Электрон Связь

Мы молодая и активно развивающаяся компания в области поставок электронных компонентов. Мы поставляем электронные компоненты отечественного и импортного производства напрямую от производителей и с крупнейших складов мира.

Благодаря сотрудничеству с мировыми поставщиками мы осуществляем комплексные и плановые поставки широчайшего спектра электронных компонентов.

Собственная эффективная логистика и склад в обеспечивает надежную поставку продукции в точно указанные сроки по всей России.

Мы осуществляем техническую поддержку нашим клиентам и предпродажную проверку качества продукции. На все поставляемые продукты мы предоставляем гарантию .

Осуществляем поставки продукции под контролем ВП МО РФ на предприятия военно-промышленного комплекса России , а также работаем в рамках 275 ФЗ с открытием отдельных счетов в уполномоченном банке. Система менеджмента качества компании соответствует требованиям ГОСТ ISO 9001.

Минимальные сроки поставки, гибкие цены, неограниченный ассортимент и индивидуальный подход к клиентам являются основой для выстраивания долгосрочного и эффективного сотрудничества с предприятиями радиоэлектронной промышленности, предприятиями ВПК и научно-исследовательскими институтами России.

С нами вы становитесь еще успешнее!

### Наши контакты:

**Телефон:** +7 812 627 14 35

**Электронная почта:** [sales@st-electron.ru](mailto:sales@st-electron.ru)

**Адрес:** 198099, Санкт-Петербург,  
Промышленная ул, дом № 19, литера Н,  
помещение 100-Н Офис 331