

AGB1N0CS-GEVK

Demo 3 Evaluation Board User's Manual



ON Semiconductor®

www.onsemi.com

Demo 3 Evaluation Board Overview

The Demo 3 Baseboard is used to connect to headboards and interface with a host PC in order to demonstrate the features of ON Semiconductor's image sensor products.

Features

- High-Bandwidth USB 3.0 Interface
- Altera Arria II GX FPGA
- HDMI® Transmitter
- 1GB Memory Buffer
- Up to 4-Lane MIPI and HiSPi Interfaces
- CCP and Parallel Interfaces
- I²C Control Unit

Block Diagram

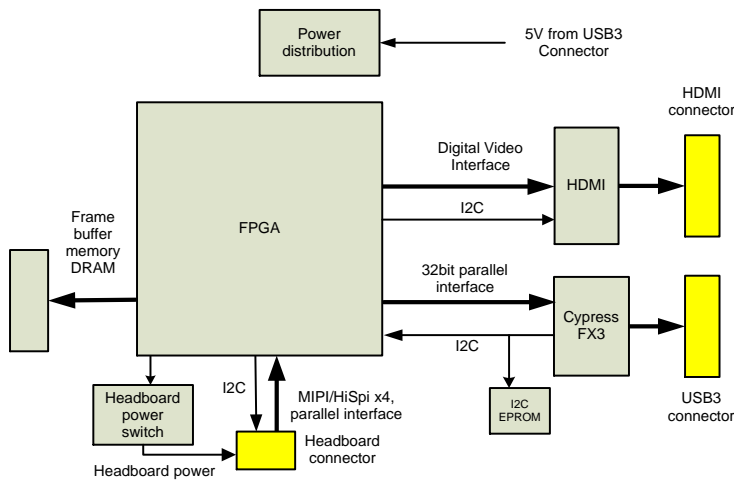

Figure 2. Block Diagram of AGB1N0CS-GEVK

EVAL BOARD USER'S MANUAL



Top View



Bottom View

Figure 1. AGB1N0CS Evaluation Board

AGB1N0CS-GEVK

Top View

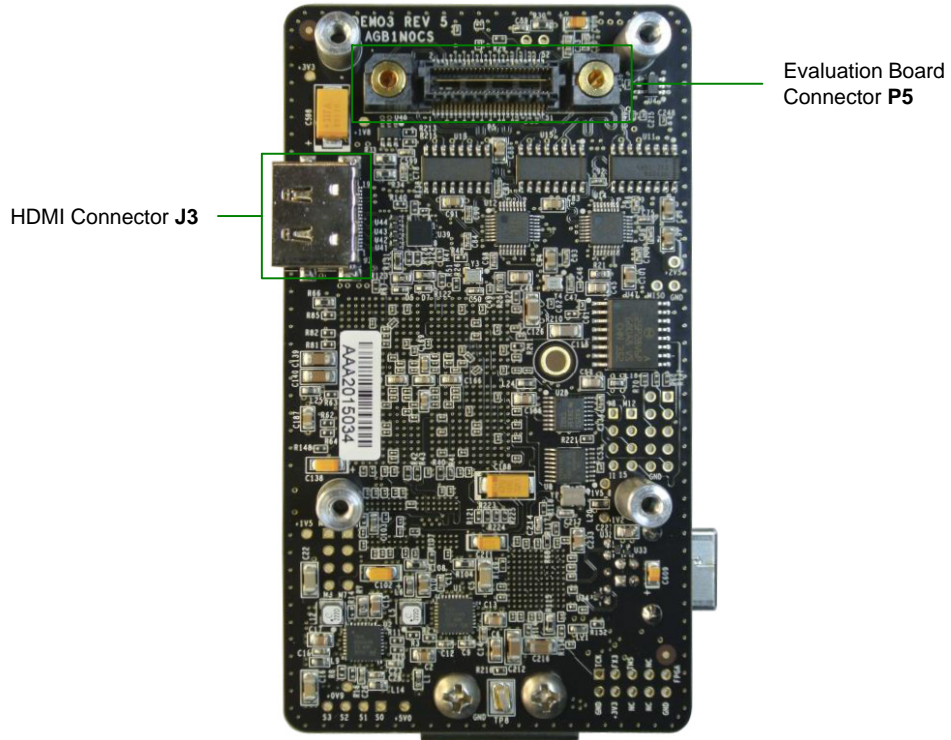

Figure 3. Top View of Demo 3 with Connectors

Bottom View

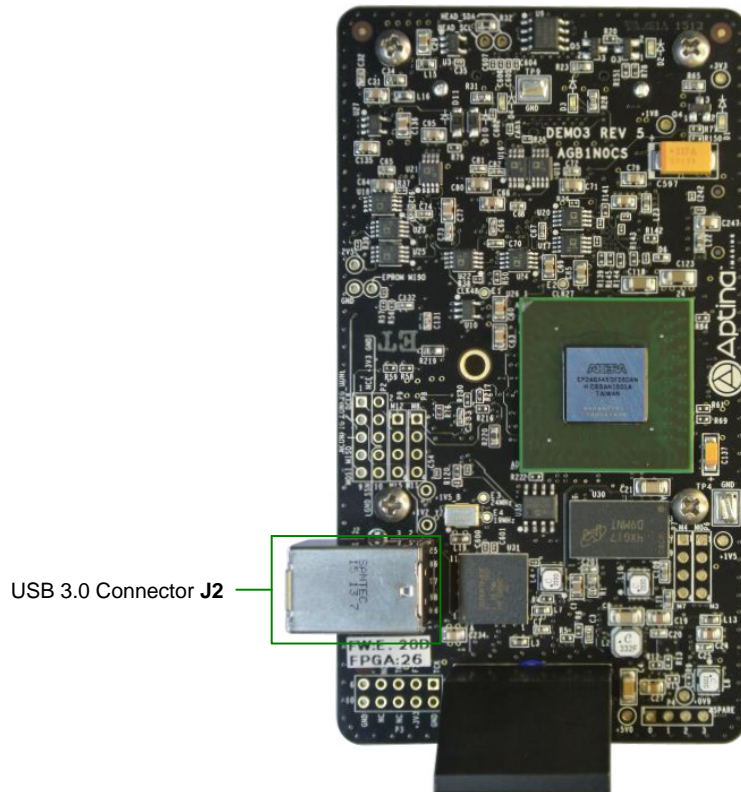

Figure 4. Bottom View of Demo 3 with Test Pins and Connectors

AGB1N0CS–GEVK

Demo 3 Baseboard Function Overview

The Demo 3's FPGA, Altera's EP2AGX45DF25C4N, provides an interface between ON Semiconductor imaging sensors and the Cypress FX3 USB 3.0 controller. An

external SPI EPROM contains the programming file for the FPGA. The EPROM is configurable using the FX3 SPI master interface. The FPGA has a memory controller block that controls data from the on-board DDR3 SDRAM.

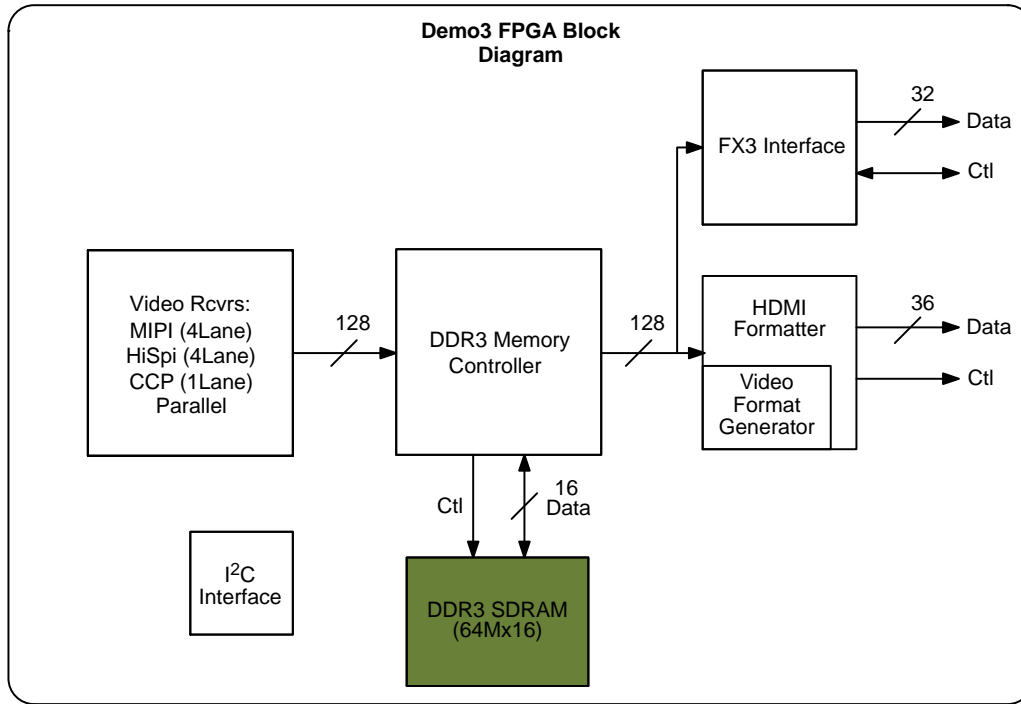

Figure 5. FPGA Block Diagram

FPGA Frame Buffer

The 1Gb frame buffer using a 64Mbx16 matches data rates between the sensor and FX3 interfaces. It is sized to buffer 3 frames of a 20-Megapixel sensor. There is a triple-buffer to help minimize frame loss. The frame buffer has two principal operating modes that support either self-timed operation or direct interface to the FX3 at HDMI video output of 720p 60 or 1080p 60 frame rates. The frame buffer controller runs at 150 MHz FPGA core clock with peak available bandwidth at 750-Megapixels/second, peak input bandwidth of 400-Megapixels/second, and peak output bandwidth of 200-Megapixels/second. The frame buffer can be configured to operate as a frame capture device, with the entire buffer filled prior to sending data to the FX3 interface.

Receivers and Data Rates

The FPGA receives data through MIPI, HiSPi, CCP, and parallel interfaces. Each of these receiver blocks has an output FIFO that moves data from the receiver clock to the 150 MHz FPGA core clock.

MIPI Receiver:

The MIPI receiver handles 4 lanes of data at a maximum data rate of 768 Mbps/lane. The signal pairs use both single-ended and differential signaling with accordance to the MIPI Alliance Specification for D-PHY v.1.00.00.

HiSPi Receiver:

The HiSPi receiver supports high-speed transmission of image sensor data, operating at 1 Gbps per data lane. It is a unidirectional differential serial interface with four data lanes and one DDR clock lane. It supports Streaming-S, Streaming-SP, and Packetized SP protocols that conform to the HiSPi protocol specification v.1.50.00.

CCP Receiver:

The CCP receiver is a single-lane data interface that supports 8-, 10-, or 12-bit raw data. It operates with a maximum serial data rate of at least 640 Mbps. The receiver conforms to the SMIA CCP2 1.0 specification.

Parallel Receiver:

The parallel receiver allows asynchronous switching between driven and high-Z under pin or register control. The receiver supports 10 or 12 bits of data, running at a pixel rate of at least 125 MHz.

HDMI Transmitter

The HDMI transmitter utilizes the ADV7526 chip by Analog Devices to transmit HDMI 34-bit data to the output port. The HDMI interface supports the HDMI 1.4 standard with 12-bit deep color. It supports RGB and YCbCr digital video input. The I²C device address is 0x72 and accesses registers inside the HDMI transmitter block.

AGB1N0CS–GEVK

FX3 USB 3.0 Interface

The Cypress FX3 has a 32-bit data interface that is transceived to the differential I/O pins on the transmitters/receivers of the FPGA. The maximum data rate of the interface is 5 Gb/s.

I²C Control Bus

The I²C control bus supports 32-bit wide GPIF II data bus and supports 14 configurable control pins. The control bus supports bus frequencies of 100 kHz, 400 kHz, and 1 MHz. Operational mode control is done through software configuration using the I²C interface from the controller. The I²C HDMI chip address is 0x72, and clock generator address is 0xD2. The system EEPROM is 0xA0 and t is configurable up to 0xAx using software.

Interfacing to Demo 3 Headboard

The headboard connector has a serial sensor data input interface, I²C control interface, power input, and parallel image data interface.

HiSPi Interface

The High Speed Serial Pixel (HiSPi) interface uses four differential data lanes and one differential clock as output and it is unidirectional. In HiSPi mode, 12- or 14-bit compressed, or 16-bit linearized data may be output. Only linear mode is supported on this interface. The HiSPi interface supports three protocols: Streaming–S, Streaming–SP, and Packetized SP.

MIPI Interface

The MIPI interface implements a serial differential sub-LVDS transmitter that supports multiple formats, error checking, and custom short packets. The interface is designed to MIPI D–PHY v1.0. When the sensor is in software standby system state, the MIPI signals enter ultra low-power state according to their nominal 0 V levels.

Serial LVDS Interface

The serial LVDS (low-voltage differential signal) interface uses four differential data lanes and one differential clock as output and it is unidirectional. In Serial LVDS mode, 8- or 10-bit compressed, or 12-bit linearized data may be output. Only linear mode is supported on this interface.

Parallel Interface

The parallel mode interface outputs 10- or 12-bit raw data for linear mode and 10- or 12-bit compressed data in High Dynamic Range, depending on the board. In this mode, FRAME_VALID and LINE_VALID signals are output on dedicated pins, along with a synchronized pixel clock two-wire serial interface.

Two-Wire Serial Interface

Some boards support a two-wire serial interface. The interface supports two modes of operation: 100 kHz for Standard mode, and 400 kHz for High-speed mode.

Table 1. 52-PIN CONNECTOR TO HEADBOARD FUNCTION DESCRIPTION (P5)

Pin	Name	Description	DIR	Comment
1	MH_DATA1_P	MIPI/HiSPi Data1+	Out	MIPI/HiSPi Data1+ Signal
2	MH_DATA2_P	MIPI/HiSPi Data2+	Out	MIPI/HiSPi Data2+ Signal
3	MH_DATA1_N	MIPI/HiSPi Data1–	Out	MIPI/HiSPi Data1– Signal
4	MH_DATA2_N	MIPI/HiSPi Data2–	Out	MIPI/HiSPi Data2– Signal
5	S_RESERVED1	General Reserved Signal 1	Out	Signal @ +3.3 V Level
6	MH_DATA3_P	MIPI/HiSPi Data3+	Out	MIPI/HiSPi Data3+ Signal
7	HEAD_MOSI	Master OOT, Slave IN Signal	I/O	Signal @ +3.3 V Level
8	MH_DATA3_N	MIPI/HiSPi Data3–	Out	MIPI/HiSPi Data3– Signal
9	S_DATA1	Parallel Data1	I/O	Parallel Interface Data Bit
10	S_DATA0	Parallel Data0	I/O	Parallel Interface Data Bit
11	S_DATA3	Parallel Data3	I/O	Parallel Interface Data Bit
12	S_DATA2	Parallel Data2	I/O	Parallel Interface Data Bit
13	S_DATA5	Parallel Data5	I/O	Parallel Interface Data Bit
14	S_DATA4	Parallel Data4	I/O	Parallel Interface Data Bit
15	VDDIO_SENSE	Reference Input for I/O Voltage	PWR	Lets Demo3 Set Voltage Level
16	S_DATA6	Parallel Data6	I/O	Parallel Interface Data Bit
17	S_DATA7	Parallel Data7	I/O	Parallel Interface Data Bit
18	S_DATA8	Parallel Data8	I/O	Parallel Interface Data Bit
19	S_DATA9	Parallel Data9	I/O	Parallel Interface Data Bit
20	S_DATA10	Parallel Data10	I/O	Parallel Interface Data Bit
21	S_DATA11	Parallel Data11	I/O	Parallel Interface Data Bit

AGB1N0CS-GEVK

Table 1. 52-PIN CONNECTOR TO HEADBOARD FUNCTION DESCRIPTION (P5) (continued)

Pin	Name	Description	DIR	Comment
22	S_DATA12	Parallel Data12	I/O	Parallel Interface Data Bit
23	S_DATA13	Parallel Data13	I/O	Parallel Interface Data Bit
24	S_DATA14	Parallel Data14	I/O	Parallel Interface Data Bit
25	S_DATA15	Parallel Data15	I/O	Parallel Interface Data Bit
26	S_SP5	General Control Signal 5	In	Signal @ +3.3 V Level
27	S_SP0	General Control Signal 0	In	Signal @ +3.3 V Level
28	S_SP1	General Control Signal 1	In	Signal @ +3.3 V Level
29	S_LINE_VALID	Serial Line Valid Signal	Out	Checks if Data has Valid Line
30	S_SP3	General Control Signal 3	In	Signal @ +3.3 V Level
31	HEAD_RESET_L	Reset Signal to Headboard	Out	Resets the Headboard Sensor
32	S_SP4	General Control Signal 4	In	Signal @ +3.3 V Level
33	S_SP2	General Control Signal 2	In	Signal @ +3.3 V Level
34	HEAD_SSN	Headboard Slave Signal	In	SPI Slave Signal to Headboard
35	S_FRAME_VALID	Parallel Frame Valid Signal	Out	Checks if Data has Valid Frame
36	S_PIXCLK	Pixel Clock	Out	Parallel Data Pixel Clock
37	HEAD_SDA	I ² C Data to Sensor	I/O	Signal @ +3.3 V Level
38	+2V8_VAA_HEAD	+2.8 V to V _{AA} on Headboard	PWR	For Powering Up the Headboard
39	+5V0_HEAD	+5 V to Headboard	PWR	For Powering Up the Headboard
40	S_RESERVED0	General Reserved Signal 0	In	Signal @ +3.3 V Level
41	HEAD_MISO	Master IN, Slave OUT Signal	I/O	Signal @ +3.3 V Level
42	+1V8_HEAD	+1.8 V to Headboard	PWR	For Powering Up the Headboard

FPGA, HDMI Chip, USB 3.0 Chip:

FPGA: Altera Arria II GX (EP2AGX45DF25C4N)

HDMI Chip: Analog Device Low-Power HDMI Transmitter (ADV7526)

USB 3.0 Chip: Cypress FX3 (CYUSB3014-BZX)

HDMI is a registered trademark of HDMI Licensing, LLC.

ON Semiconductor and the  are registered trademarks of Semiconductor Components Industries, LLC (SCILLC) or its subsidiaries in the United States and/or other countries. SCILLC owns the rights to a number of patents, trademarks, copyrights, trade secrets, and other intellectual property. A listing of SCILLC's product/patent coverage may be accessed at www.onsemi.com/site/pdf/Patent-Marking.pdf. SCILLC reserves the right to make changes without further notice to any products herein. SCILLC makes no warranty, representation or guarantee regarding the suitability of its products for any particular purpose, nor does SCILLC assume any liability arising out of the application or use of any product or circuit, and specifically disclaims any and all liability, including without limitation special, consequential or incidental damages. "Typical" parameters which may be provided in SCILLC data sheets and/or specifications can and do vary in different applications and actual performance may vary over time. All operating parameters, including "Typicals" must be validated for each customer application by customer's technical experts. SCILLC does not convey any license under its patent rights nor the rights of others. SCILLC products are not designed, intended, or authorized for use as components in systems intended for surgical implant into the body, or other applications intended to support or sustain life, or for any other application in which the failure of the SCILLC product could create a situation where personal injury or death may occur. Should Buyer purchase or use SCILLC products for any such unintended or unauthorized application, Buyer shall indemnify and hold SCILLC and its officers, employees, subsidiaries, affiliates, and distributors harmless against all claims, costs, damages, and expenses, and reasonable attorney fees arising out of, directly or indirectly, any claim of personal injury or death associated with such unintended or unauthorized use, even if such claim alleges that SCILLC was negligent regarding the design or manufacture of the part. SCILLC is an Equal Opportunity/Affirmative Action Employer. This literature is subject to all applicable copyright laws and is not for resale in any manner.

PUBLICATION ORDERING INFORMATION

LITERATURE FULFILLMENT:

Literature Distribution Center for ON Semiconductor
 19521 E. 32nd Pkwy, Aurora, Colorado 80011 USA
Phone: 303-675-2175 or 800-344-3860 Toll Free USA/Canada
Fax: 303-675-2176 or 800-344-3867 Toll Free USA/Canada
Email: orderlit@onsemi.com

N. American Technical Support: 800-282-9855 Toll Free
 USA/Canada
Europe, Middle East and Africa Technical Support:
 Phone: 421 33 790 2910
Japan Customer Focus Center
 Phone: 81-3-5817-1050

ON Semiconductor Website: www.onsemi.com
Order Literature: <http://www.onsemi.com/orderlit>
 For additional information, please contact your local
 Sales Representative



Стандарт Электрон Связь

Мы молодая и активно развивающаяся компания в области поставок электронных компонентов. Мы поставляем электронные компоненты отечественного и импортного производства напрямую от производителей и с крупнейших складов мира.

Благодаря сотрудничеству с мировыми поставщиками мы осуществляем комплексные и плановые поставки широчайшего спектра электронных компонентов.

Собственная эффективная логистика и склад в обеспечивает надежную поставку продукции в точно указанные сроки по всей России.

Мы осуществляем техническую поддержку нашим клиентам и предпродажную проверку качества продукции. На все поставляемые продукты мы предоставляем гарантию .

Осуществляем поставки продукции под контролем ВП МО РФ на предприятия военно-промышленного комплекса России , а также работаем в рамках 275 ФЗ с открытием отдельных счетов в уполномоченном банке. Система менеджмента качества компании соответствует требованиям ГОСТ ISO 9001.

Минимальные сроки поставки, гибкие цены, неограниченный ассортимент и индивидуальный подход к клиентам являются основой для выстраивания долгосрочного и эффективного сотрудничества с предприятиями радиоэлектронной промышленности, предприятиями ВПК и научно-исследовательскими институтами России.

С нами вы становитесь еще успешнее!

Наши контакты:

Телефон: +7 812 627 14 35

Электронная почта: sales@st-electron.ru

Адрес: 198099, Санкт-Петербург,
Промышленная ул, дом № 19, литера Н,
помещение 100-Н Офис 331