

QUINT-PS/ 1AC/24DC/40

SFB
TECHNOLOGY

Power supply unit

INTERFACE

Data sheet
104317_en_01



© PHOENIX CONTACT 2010-04-27

1 Description

QUINT POWER power supply units – Maximum system availability with SFB technology
Compact power supply units of the new QUINT POWER generation maximize the availability of your system. With the SFB technology (Selective Fuse Breaking Technology), six times the nominal current for 12 ms, even the standard power circuit-breakers can now also be triggered reliably and quickly. Faulty current paths are switched off selectively, the fault is located and important system parts continue to operate. Comprehensive diagnostics are provided through constant monitoring of output voltage and current. This preventive function monitoring visualizes critical operating modes and reports them to the control unit before an error can occur.

Features

- Quick tripping of the standard power circuit-breakers using dynamic power reserve SFB technology
- Reliable starting of difficult loads with static POWER BOOST power reserve
- Preventive function monitoring
- Can be used worldwide
- High degree of operational safety due to high MTBF > 500 000 h, long mains buffering times > 20 ms, high dielectric strength up to 300 V AC



DANGER OF EXPLOSION!

Only remove equipment when it is disconnected and not in the potentially explosive area.



DANGER

The device contains dangerous live elements and high levels of stored energy.
Never carry out work when the power is turned on.



Make sure you always use the latest documentation.
It can be downloaded from the product at www.phoenixcontact.net/catalog.

2 Table of contents

1 Description 1
 Features..... 1

2 Table of contents.....2

3 Ordering data3

4 Technical data3

5 Structure.....7

6 Block diagram8

7 Safety and warning notes8

8 Installation9

9 Installation position.....9

10 Mounting on DIN rails 10
 Slim-style installation 10
 Mounting position rotated 90° 10

11 Connection to various systems..... 11

12 Input 11
 Protection of the primary side..... 11
 Permissible backup fuse for mains protection 11

13 Output 12
 Protection of the secondary side..... 12

14 Signaling 12
 Floating contact..... 13
 Active signal outputs 13
 Signal loop 13

15 Function 14
 Output characteristic curve 14
 Thermal behavior 14
 Parallel operation 15
 Redundant operation 15
 Increased performance 15

3 Ordering data

Description	Type	Order No.	Pcs. / Pkt.
24 V DC/40 A DIN rail power supply unit, primary-switched, single-phase. SFB (selective fuse breaking) technology can be also used to trigger standard circuit breakers quickly and reliably.	QUINT-PS/ 1AC/24DC/40	2866789	1

Accessories	Type	Order No.	Pcs. / Pkt.
Universal wall adapter	UWA 182/52	2938235	1

4 Technical data

Input data

Input nominal voltage range	100 V AC ... 240 V AC
AC input voltage range	85 V AC ... 264 V AC
DC input voltage range	90 V DC ... 300 V DC (UL 508: ≤ 250 V DC)
AC frequency range	45 Hz ... 65 Hz
DC frequency range	0 Hz
Current consumption	Approx. 8.8 A (120 V AC) Approx. 4.6 A (230 V AC) Approx. 8.8 A (120 V DC) Approx. 4.2 A (250 V DC)
Inrush current limitation	< 15 A (typical)
i^2t	< 1.7 A ² s
Power failure bypass	> 20 ms (120 V AC) > 20 ms (230 V AC)
Typical response time	< 1 s
Protective circuitry	Transient surge protection Varistor
Input fuse, integrated	20 A (slow-blow, internal)
Discharge current to PE	< 3.5 mA

Output data

Nominal output voltage	24 V DC ±1%
Setting range of the output voltage	18 V DC ... 29.5 V DC (> 24 V constant capacity)
Output current	40 A (-25°C ... 60°C, U _{OUT} = 24 V DC) 45 A (with POWER BOOST, -25°C ... 40°C permanently, U _{OUT} = 24 V DC) 215 A (with SFB technology, 12 ms)
Derating	60°C to 70°C: 2.5%/K. Below 100 V AC: 1%/V. Below 120 V DC: 0.5%/V.
Efficiency	> 92 % (for 230 V AC and nominal values)
Residual ripple	< 100 mV _{PP} (with nominal values)
Connection in parallel	Yes, for redundancy and increased capacity
Connection in series	Yes
Surge protection against internal surge voltages	Yes, limited to approx. 35 V DC
Resistance to reverse feed	35 V DC

Power consumption

Maximum power dissipation idling	< 14 W
Power loss nominal load max.	< 80 W

DC OK active

Output description	$U_{OUT} > 0.9 \times U_N$: High signal
Voltage	+ 18 V DC ... 24 V DC
Current	≤ 20 mA (short circuit resistant)
Status display	$U_{OUT} > 0.9 \times U_N$: "DC OK" LED green / $U_{OUT} < 0.9 \times U_N$: Flashing "DC OK" LED

DC OK floating

Output description	Relay contact, $U_{OUT} > 0.9 \times U_N$: Contact closed
Voltage	≤ 30 V AC/DC
Current	≤ 1 A (≤ 0.5 A at 60 V DC)
Status display	$U_{OUT} > 0.9 \times U_N$: "DC OK" LED green / $U_{OUT} < 0.9 \times U_N$: Flashing "DC OK" LED

POWER BOOST, active

Output description	$I_{OUT} < I_N$: High signal
Voltage	+ 18 V DC ... 24 V DC
Current	≤ 20 mA
Status display	$I_{OUT} > I_N$: LED "BOOST" yellow

General data

Insulation voltage input/output	4 kV AC (type test) 2 kV AC (routine test)
Insulation voltage input / PE	3.5 kV AC (type test) 2 kV AC (routine test)
Insulation voltage output / PE	500 V DC (routine test)
Degree of protection	IP20
Class of protection	I, with PE connection
MTBF	> 500 000 h in acc. with IEC 61709 (SN 29500)
Type of housing	Steel sheet, zinc-plated
Housing material	Steel sheet, zinc-plated
Dimensions W / H / D (state of delivery)	180 mm / 130 mm / 125 mm
Dimensions W / H / D (90° turned)	122 mm / 130 mm / 183 mm
Weight	3.3 kg

Ambient conditions

Ambient temperature (operation)	-25 °C ... 70 °C (> 60 °C derating)
Ambient temperature (storage/transport)	-40 °C ... 85 °C
Max. permissible relative humidity (operation)	≤ 95 % (at 25 °C, no condensation)
Vibration (operation)	< 15 Hz, amplitude ± 2.5 mm in acc. with IEC 60068-2-6 15 Hz ... 150 Hz, 2.3g, 90 min.
Shock	30g in all directions in acc. with IEC 60068-2-27
Pollution degree in acc. with EN 50178	2
Climatic class	3K3 (in acc. with EN 60721)

Standards

Electrical Equipment for Machinery	EN 60204
Safety transformers for power supply units	IEC 61558-2-17
Electrical safety (of information technology equipment)	IEC 60950/VDE 0805 (SELV)
Electronic equipment for use in electrical power installations	EN 50178/VDE 0160 (PELV)
SELV	IEC 60950 (SELV) and EN 60204 (PELV)
Safe isolation	DIN VDE 0100-410 DIN VDE 0106-101
Protection against electric shock	DIN 57100-410

Standards (Continued)

Protection against electric shock, basic requirements for safe isolation in electrical equipment	DIN VDE 0106-101
Limitation of mains harmonic currents	EN 61000-3-2
Device safety	BG (design tested)
Certificate	CB Scheme

Approvals

UL approvals UL applied for



Current approvals can be found for the product in the download area.

Conformance with EMC guideline 2004/108/EC and for low-voltage guideline 2006/95/EC

Noise immunity according to EN 61000-6-2

Electrostatic discharge	EN 61000-4-2	
	Housing	Level 4
	Contact discharge	8 kV
	Discharge in air	15 kV
	Comments	Criterion B
Electromagnetic HF field	EN 61000-4-3	
	Housing	Level 4
	Frequency range	80 MHz ... 1000 MHz
	Field intensity	20 V/m
	Frequency range	1 GHz ... 3 GHz
	Field intensity	10 V/m
	Comments	Criterion A
Fast transients (burst)	EN 61000-4-4	
	Input	4 kV (level 4 - asymmetrical: conductor to ground)
	Output	2 kV (level 3 - asymmetrical: conductor to ground)
	Signal	1 kV (level 1 - asymmetrical: conductor to ground)
	Comments	Criterion B
Surge current loads (surge)	EN 61000-4-5	
	Input	4 kV (level 4 - asymmetrical: conductor to ground) 2 kV (level 4 - symmetrical: conductor to conductor)
	Output	2 kV (level 3 - asymmetrical: conductor to ground) 1 kV (Level 3 - symmetrical: Conductor to conductor)
	Signal	1 kV (level 3 - asymmetrical: conductor to ground)
	Comments	Criterion B
Conducted interference	EN 61000-4-6	
	Input/Output/Signal	Level 3
	Frequency range	0.15 MHz ... 80 MHz
	Voltage	10 V
	Comments	Criterion A
Voltage dips	EN 61000-4-11	
	Input	(Mains buffering time > 20 ms (Semi F47-0706))
	Comments	Criterion B

Conformance with EMC guideline 2004/108/EC and for low-voltage guideline 2006/95/EC (Continued)

Noise immunity according to EN 61000-6-2

Simulation mobile phones	ENV 50204
Frequency	900 MHz / 1800 MHz
Field intensity	20 V/m

Emitted interference in acc. with EN 61000-6-3

Radio interference voltage in acc. with EN 55011	EN 55011 (EN 55022) Class B, area of application: Industry and residential
Emitted radio interference in acc. with EN 55011	EN 55011 (EN 55022) Class B, area of application: Industry and residential

5 Structure

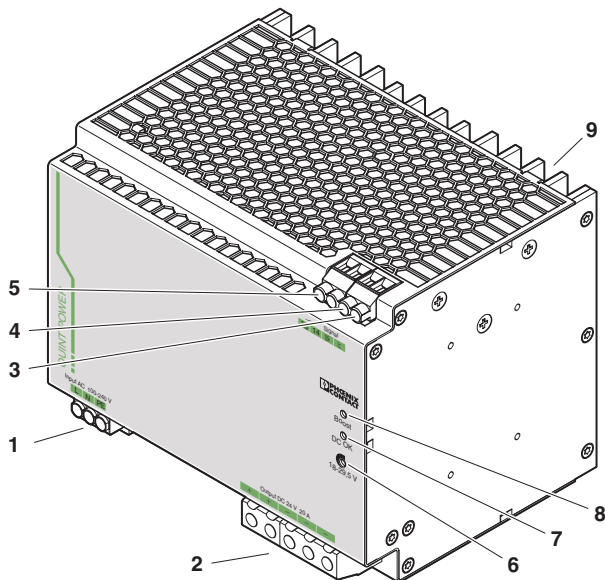

- 1 AC input
- 2 DC output
- 3 POWER BOOST switching output, active
- 4 DC OK switching output active
- 5 DC OK output, floating
- 6 Potentiometer 18 ... 29.5 V DC
- 7 "DC OK" LED, green
- 8 LED "BOOST", yellow
- 9 Universal DIN rail adapter UTA 107/30

	[mm ²]		AWG	[Nm] Torque
	solid	stranded		
Input	0.2 - 6	0.2 - 4	18 - 10	0.5 - 0.6
Output	0.5 - 16	0.5 - 16	8 - 6	1.2 - 1.5
Signal	0.2 - 6	0.2 - 4	18 - 10	0.5 - 0.6

Input data

Input nominal voltage range	100 V AC ... 240 V AC
AC input voltage range	85 V AC ... 264 V AC
DC input voltage range	90 V DC ... 300 V DC (UL 508: ≤ 250 V DC)
AC frequency range	45 Hz ... 65 Hz
DC frequency range	0 Hz
Input fuse, integrated	20 A (slow-blow, internal)
Type of connection	Screw connection
Stripping length	7 mm

Output data

Nominal output voltage	24 V DC ±1%
Setting range of the output voltage	18 V DC ... 29.5 V DC (> 24 V constant capacity)
Output current	40 A (-25°C ... 60°C, U _{OUT} = 24 V DC) 45 A (with POWER BOOST, -25°C ... 40°C permanently, U _{OUT} = 24 V DC) 215 A (with SFB technology, 12 ms)
Type of connection	Screw connection
Stripping length	10 mm

6 Block diagram

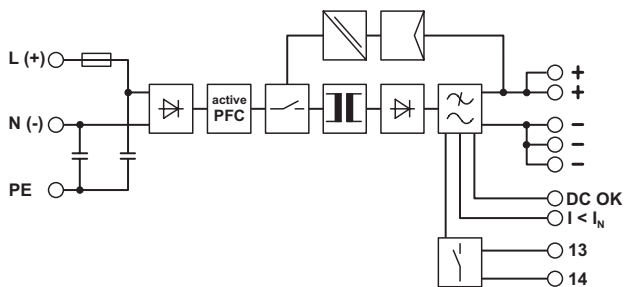

7 Safety and warning notes



DANGER OF EXPLOSION!

Only remove equipment when it is disconnected and not in the potentially explosive area.

DANGER

The device contains dangerous live elements and high levels of stored energy. Never carry out work when the power is turned on.



WARNING

Before startup please ensure:

The mains connection has been carried out by a competent person and protection against electric shock is guaranteed!

The device can be disconnected outside the power supply unit in accordance with the regulations as in EN 60950 (e.g. through primary side line protection)!

The ground conductor is connected!

All feed lines are sufficiently protected and dimensioned!

All output lines are dimensioned according to the maximum output current of the device or separately protected!

Sufficient convection must be guaranteed.



CAUTION

The power supply units are built-in devices. The device may only be installed and put into operation by qualified personnel. The corresponding national regulations must be observed.

8 Installation

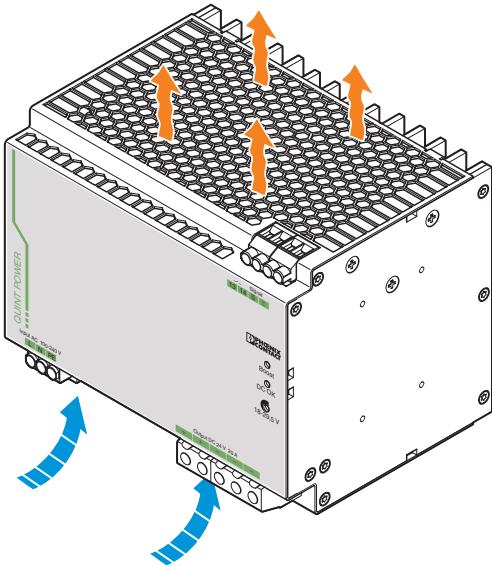

ATTENTION
In order to ensure sufficient convection, we recommend a minimum vertical distance of 5 cm to the other modules.
A lateral distance of 5 mm, and in the case of active components, that of 15 mm is necessary for proper functioning of the module.
Depending on the ambient temperature and the load of the module, the housing can become very hot.



The power supply unit can be snapped onto all DIN rails in acc. with EN 60715. They must be mounted horizontally (connecting terminal blocks top and bottom).

9 Installation position

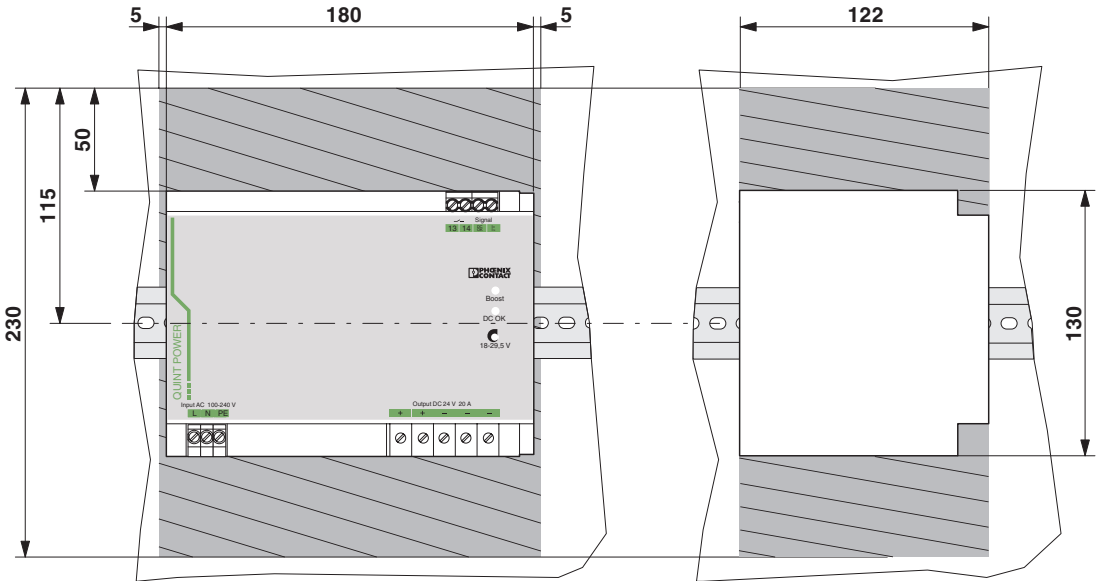

Slim-style installation: Installation depth 125 mm (+ DIN rail)
(state at delivery)

Mounting position rotated 90°: Installation depth 180 mm
(+ DIN rail)

10 Mounting on DIN rails

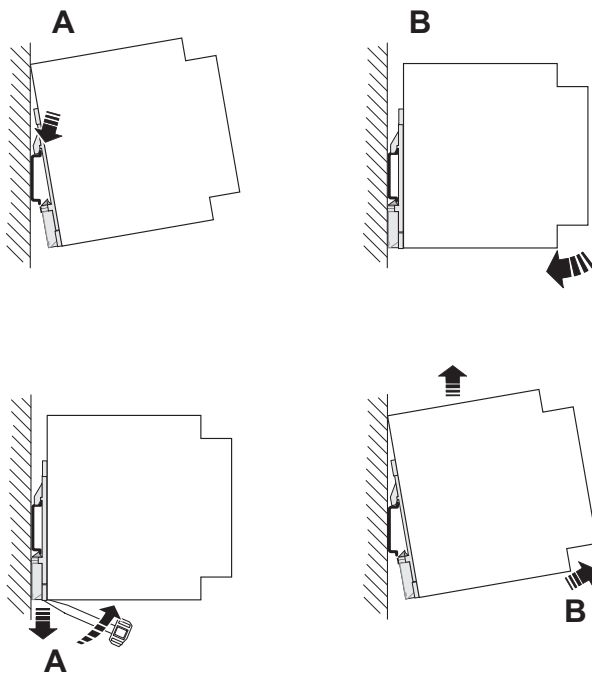

Slim-style installation

Assembly:

Position the module with the DIN rail guide on the upper edge of the DIN rail, and snap it in with a downward motion.

Removing:

Pull the snap lever open with the aid of a screwdriver and slide the module out at the lower edge of the DIN rail.

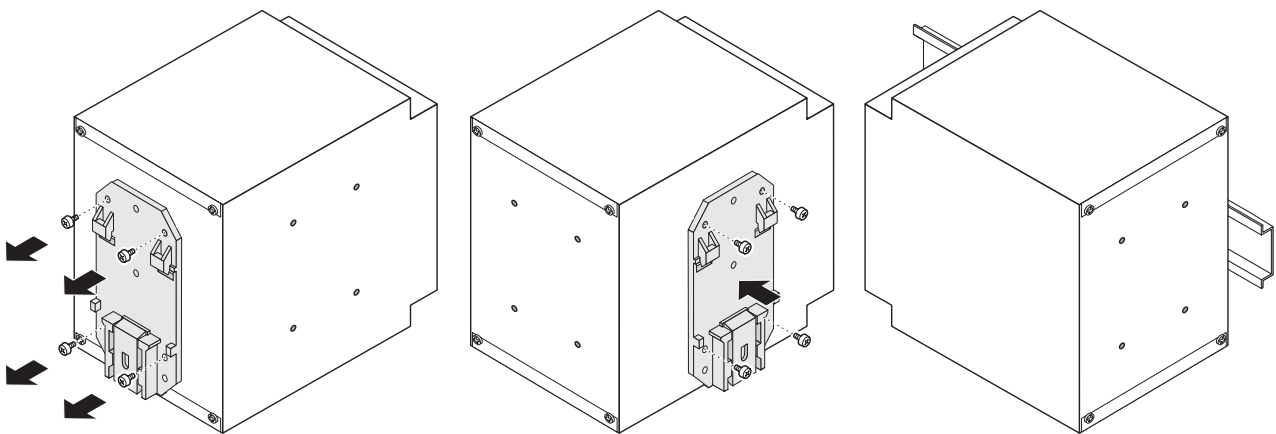

Mounting position rotated 90°

For a mounting position rotated at 90° to the DIN rail, mount the DIN rail adapter (UTA 107/30) as shown in the figure. No additional assembly material is required. Fixing screws: Torx T10 (torque 0.8 Nm ... 0.9 Nm).

11 Connection to various systems

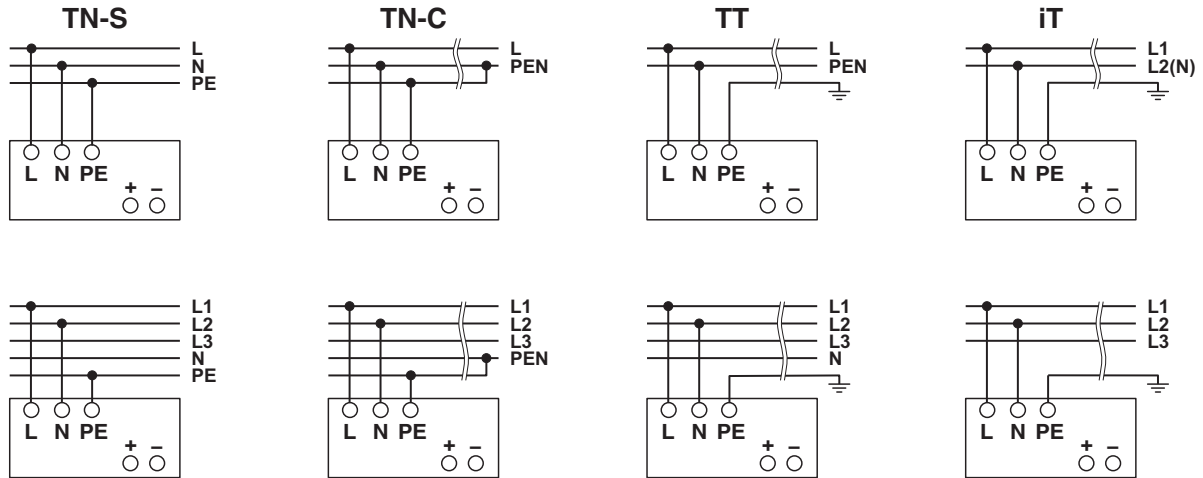

The connection for 100 V AC ... 240 V AC is established using the L, N, and P screw connections.

The device can be connected to 1-phase AC networks or to two of the phase conductors of three-phase systems (TN, TT or IT systems) in accordance with VDE 0100-300/IEC 60364-3) with nominal voltages of 100 V AC ... 240 V AC.

The device also continues to work on short-term input voltages > 300 V AC.



For operation on two of the phase conductors of a three-phase system, an isolating facility for all poles must be provided.

12 Input

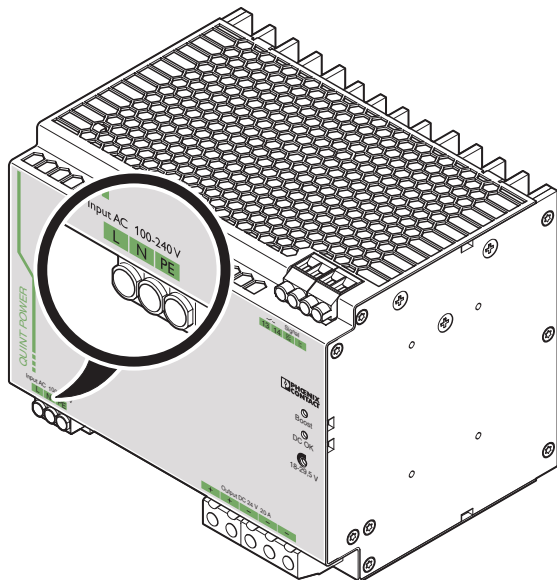

CAUTION

If an internal fuse is triggered, there is a device malfunction. In this case, the device must be inspected in the factory.

Protection of the primary side

The device must be installed in acc. with the regulations as in EN 60950. It must be possible to disconnect the device using a suitable isolating facility outside the power supply.

The primary side line protection, for example, is suitable. For device protection, there is an internal fuse. Additional device protection is not necessary.

Permissible backup fuse for mains protection

Power circuit breaker 16 A or 20 A, characteristic B (or identical function). In DC applications, a suitable fuse must be wired upstream.

13 Output

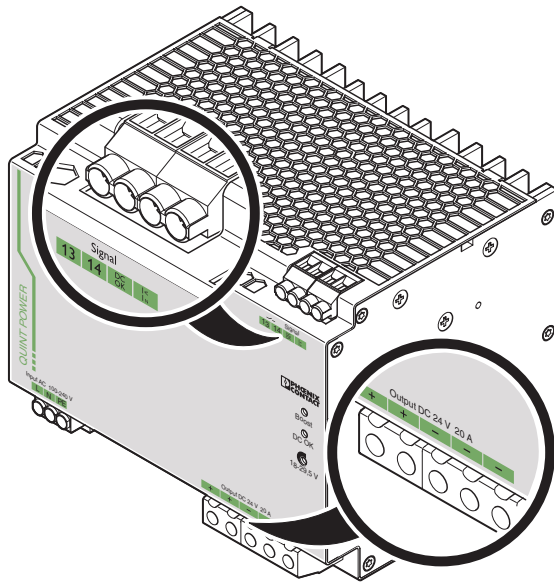

CAUTION

Make sure that all output lines are dimensioned according to the maximum output current or are separately protected. The cables on the secondary side must have sufficiently large cross sections in order to keep the voltage drops on the lines as low as possible.

The connection is established using screw connections on the screw connection of the DC output:
 24 V DC: "+" and "-"; DC OK switching output active: "DC OK" and "-"; DC OK output floating: "13" and "14"; POWER BOOST switching output active: " $I < I_N$ " and "-".
 At the time of delivery, the output voltage is 24 V DC. The output voltage can be set on the potentiometer.

Protection of the secondary side

The device is electronically protected against short circuit and idling. In the event of a malfunction, the output voltage is limited to 35 V DC.

14 Signaling

An active signal output DC OK, a floating signal contact DC OK and an active signal output POWER BOOST are available for function monitoring. In addition, the DC OK LED and the BOOST LED can be used to evaluate the function of the power supply directly at the installation location (see output characteristic curve).

	$I < I_N$	$I > I_N$	$U_{OUT} < 0.9 \times U_N$
"DC OK" LED	ON	ON	Flashing
"BOOST" LED	OFF	ON	ON
Active DC OK switching output	ON	ON	OFF
Floating DC OK output	Closed	Closed	Open
Active POWER BOOST switching output	ON	OFF	OFF
Meaning	Normal operation of the power supply unit ($U_{OUT} > 21.5 \text{ V}$)	POWER BOOST operation, e.g. to start loads	Overload mode, e.g. consumer short circuit or overload

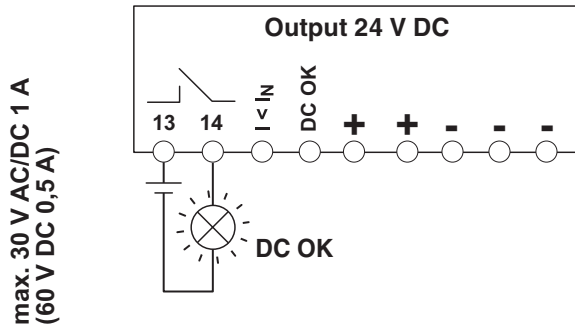

Floating contact

The floating signal contact opens and indicates that the set output voltage has been undershot by more than 10 %. Signals and ohmic loads up to a maximum of 30 V AC/DC and currents to a maximum of 1 A (or maximum of 60 V DC with a maximum of 0.5 A) can be switched. For heavily inductive loads such as a relay, a suitable protection circuit (e.g., damping diode) is necessary.

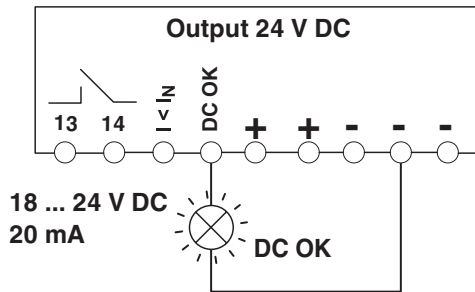

Active signal outputs

The 18 ... 24 V DC signal is applied between the "DC OK" and the "-" connecting terminal blocks or between "I < I_N" and "-" and can carry a maximum of 20 mA. By switching from "active high" to "low", the DC OK signal output signalizes when the set output voltage is fallen short of by more than 10 %. The DC OK signal is decoupled from the power output. It is thus not possible for devices connected in parallel to act as an external power supply. The POWER BOOST signal output I < I_N signalizes that the nominal current is exceeded. The power supply is then in POWER BOOST mode. Thanks to this preventive function monitoring, critical operating states can be responded to at an early stage, prior to a voltage dip occurring. The 18 ... 24 V DC signal can be directly connected to a logic input for evaluation.

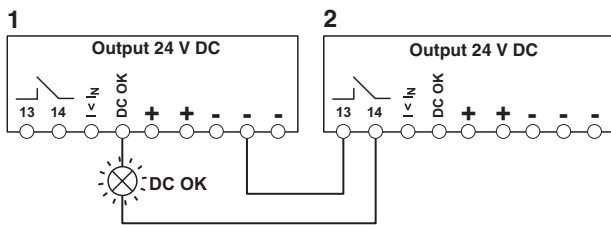

Signal loop

Monitoring two devices: Use the active signal output of device 1 and loop in the floating signal output of device 2. In the event of malfunctioning, a common alarm is output. Any number of devices can be looped in. This signal combination saves wiring costs and logic inputs.

15 Function

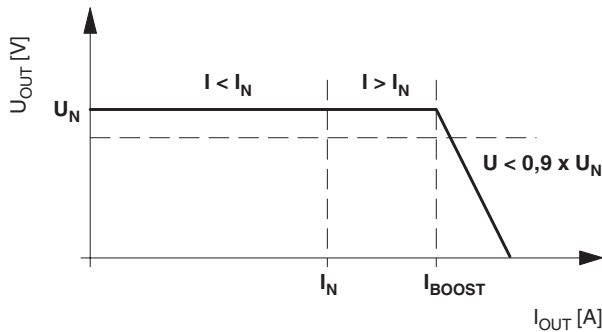

Output characteristic curve

The power supply works with the static POWER BOOST power reserve as shown in the U/I characteristic curve in the figure. At ambient temperatures $T_{amb} < +40\text{ }^\circ\text{C}$, I_{BOOST} is available continuously. At higher temperatures, it is available for a few minutes. In the event of a secondary-side short circuit or overload, the output current is limited to I_{BOOST} . Thereby, the module does not switch off, but rather supplies a continuous output current. The secondary voltage is reduced here until the short circuit is eliminated. The U/I characteristic curve with the POWER BOOST power reserve ensures that both high inrush currents of capacitive loads as well as loads with DC/DC converters in the primary circuit can be supplied.

In order to trip standard circuit breakers magnetically and therefore quickly, power supply units have to provide a multiple of the nominal current for a short time.

The characteristic curve shows when $I < I_N$, $I > I_N$ and $U < 0.9 \times U_N$. The "signaling" table is to be consulted for the respective signaling.

$$U_N = 24\text{ V}$$

$$I_N = 40\text{ A}$$

$$I_{BOOST} = 45\text{ A}$$

$$\text{SFB technology} = 215\text{ A (for 12 ms)}$$

$$P_N = 960\text{ W}$$

$$P_{BOOST} = 1080\text{ W}$$

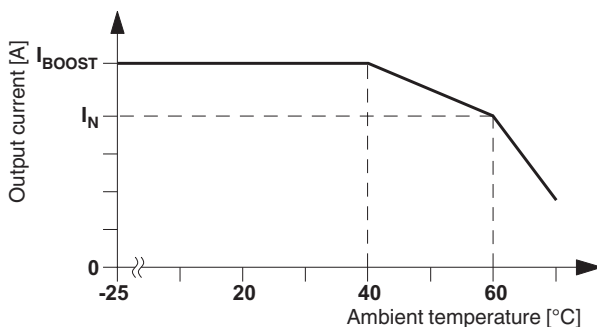

Thermal behavior

With an ambient temperature of up to $+40\text{ }^\circ\text{C}$, the device supplies the continuous output current of I_{BOOST} . The device can supply a nominal output current of I_N with ambient temperatures of up to $+60\text{ }^\circ\text{C}$. In the case of ambient temperatures above $+60\text{ }^\circ\text{C}$, the output current must be reduced by 2.5% per Kelvin increase in temperature. The device does not switch off at ambient temperatures of $+70\text{ }^\circ\text{C}$ or thermal overload. The output capacity is reduced as far as necessary to provide device protection. After it has cooled down, the output capacity is increased again.

Parallel operation

Devices of the same type can be connected in parallel to increase both redundancy and power. By default upon delivery, no further adjustments are required. If the output voltage is adjusted, a uniform distribution of power is guaranteed by setting all parallel operated power supply units to exactly the same output voltage. To ensure symmetrical current distribution we recommend that all cable connections from the power supply unit to the busbar are the same length and have the same cross section. Depending on the system, for parallel connection of more than two power supplies a protective circuit should be installed at each individual device output (e.g., decoupling diode, DC fuse or circuit breaker). This prevents high return currents in the event of a secondary device fault.

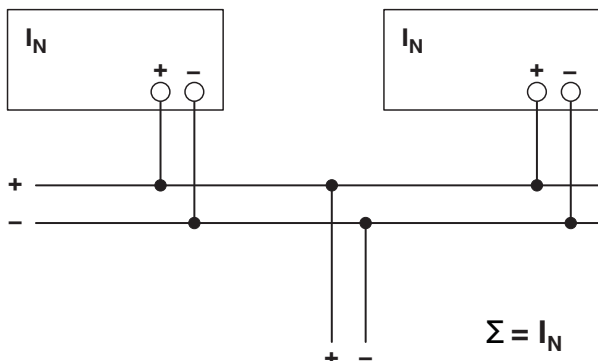

Redundant operation

Redundant circuits are suitable for the supply of systems which make especially high requirements on the operational safety. If a fault occurs in the primary circuit of the first power supply unit, the second device automatically takes over the entire power supply, without interruption, and vice versa. For this reason, the power supply units to be connected in parallel are dimensioned in such a way that the total current requirement of all consumers can be completely covered by one power supply unit. 100% redundancy makes external decoupling diodes necessary (QUINT-DIODE/40, Order No. 2938963)!

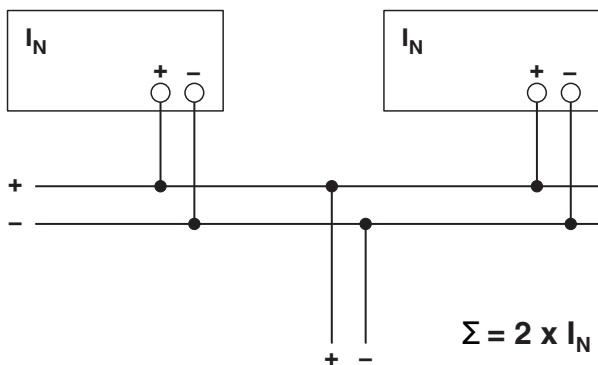

Increased performance

For n parallel connected devices, the output current can be increased to $n \times I_N$. Parallel connection for increasing power is used when extending existing systems. A parallel connection is recommended if the power supply unit does not cover the current consumption of the most powerful load. Otherwise, the load should be divided between individual devices that are independent from one another.



Стандарт Электрон Связь

Мы молодая и активно развивающаяся компания в области поставок электронных компонентов. Мы поставляем электронные компоненты отечественного и импортного производства напрямую от производителей и с крупнейших складов мира.

Благодаря сотрудничеству с мировыми поставщиками мы осуществляем комплексные и плановые поставки широчайшего спектра электронных компонентов.

Собственная эффективная логистика и склад в обеспечивает надежную поставку продукции в точно указанные сроки по всей России.

Мы осуществляем техническую поддержку нашим клиентам и предпродажную проверку качества продукции. На все поставляемые продукты мы предоставляем гарантию .

Осуществляем поставки продукции под контролем ВП МО РФ на предприятия военно-промышленного комплекса России , а также работаем в рамках 275 ФЗ с открытием отдельных счетов в уполномоченном банке. Система менеджмента качества компании соответствует требованиям ГОСТ ISO 9001.

Минимальные сроки поставки, гибкие цены, неограниченный ассортимент и индивидуальный подход к клиентам являются основой для выстраивания долгосрочного и эффективного сотрудничества с предприятиями радиоэлектронной промышленности, предприятиями ВПК и научно-исследовательскими институтами России.

С нами вы становитесь еще успешнее!

Наши контакты:

Телефон: +7 812 627 14 35

Электронная почта: sales@st-electron.ru

Адрес: 198099, Санкт-Петербург,
Промышленная ул, дом № 19, литера Н,
помещение 100-Н Офис 331