

Revision History List**512K x 16 bit -AS6C8016-55TIN - 48-pin TSOP I PACKAGE**

Revision	Details	Date
Rev. 1.0	Initial Issue	November12.2015

FEATURES

- Fast access time : 55ns
- Low power consumption:
Operating current : 30/20mA (TYP.)
Standby current : 1.5 μ A (TYP.) SL-version
- Single 2.7V ~ 3.6V power supply
- All inputs and outputs TTL compatible
- Fully static operation
- Tri-state output
- Data byte control : LB# (DQ0 ~ DQ7)
UB# (DQ8 ~ DQ15)
- Data retention voltage : 1.2V(MIN.)
- Package : 48-pin 12mm x 20mm TSOP-I
- Green & ROHS Compliant

GENERAL DESCRIPTION

The AS6C8016-55TIN is a 8,388,608-bit low power CMOS static random access memory organized as 524,288 words by 16 bits. It is fabricated using very high performance, high reliability CMOS technology. Its standby current is stable within the range of operating temperature.

The AS6C8016-55TIN is well designed for low power application, and particularly well suited for battery back-up nonvolatile memory application.

The AS6C8016-55TIN operates from a single power supply of 2.7V ~ 3.6V and all inputs and outputs are fully TTL compatible

FUNCTIONAL BLOCK DIAGRAM

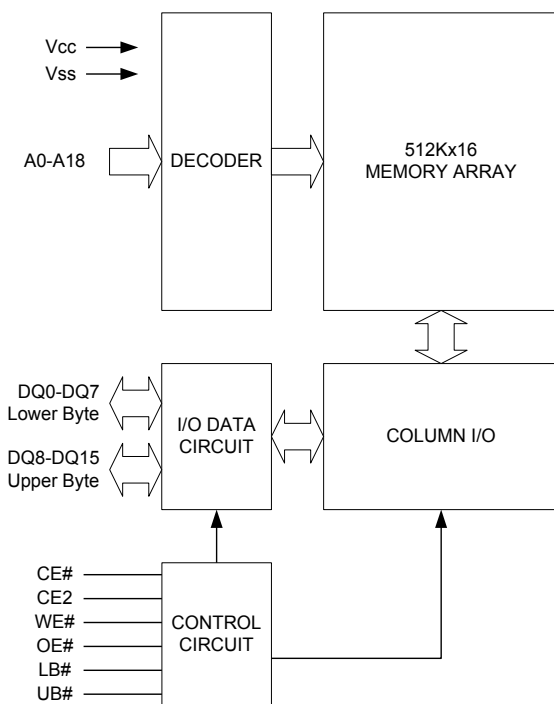

PIN DESCRIPTION

SYMBOL	DESCRIPTION
A0 - A18	Address Inputs
DQ0 - DQ15	Data Inputs/Outputs
CE#, CE2	Chip Enable Input
WE#	Write Enable Input
OE#	Output Enable Input
LB#	Lower Byte Control
UB#	Upper Byte Control
Vcc	Power Supply
Vss	Ground

PRODUCT FAMILY

Product Family	Operating Temperature	Vcc Range	Speed	Power Dissipation	
				Standby(I _{SB1} , TYP.)	Operating(I _{CC} , TYP.)
AS6C8016-55TIN	-40°C ~ 85°C	2.7 ~ 3.6V	55ns	1.5 μ A(SL)	30/20mA

PIN CONFIGURATION

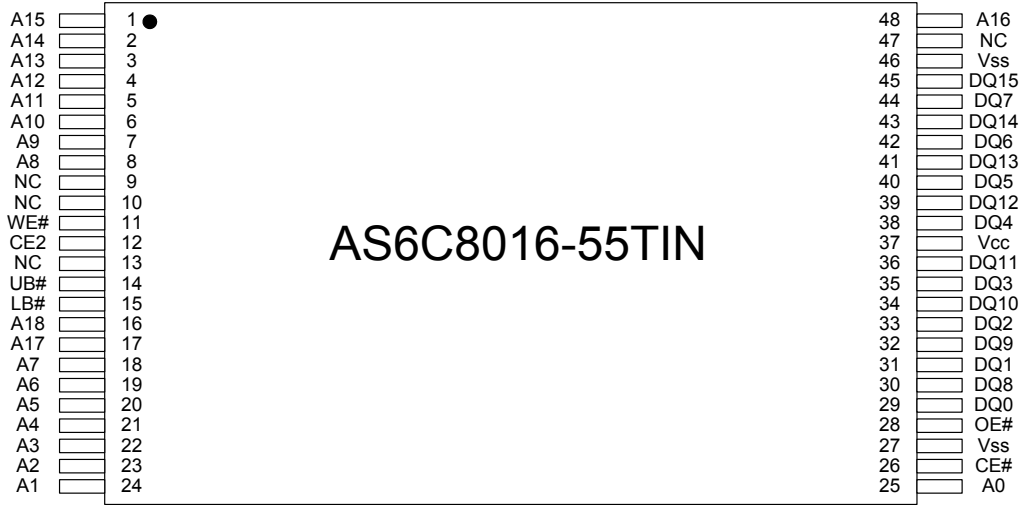

TSOP-I

ABSOLUTE MAXIMUM RATINGS*

PARAMETER	SYMBOL	RATING	UNIT
Voltage on Vcc relative to Vss	V _{T1}	-0.5 to 4.6	V
Voltage on any other pin relative to Vss	V _{T2}	-0.5 to Vcc+0.5	V
Operating Temperature	T _A	0 to 70(C grade)	°C
		-40 to 85(I grade)	
Storage Temperature	T _{STG}	-65 to 150	°C
Power Dissipation	P _D	1	W
DC Output Current	I _{OUT}	50	mA

*Stresses greater than those listed under "Absolute Maximum Ratings" may cause permanent damage to the device. This is a stress rating only and functional operation of the device or any other conditions above those indicated in the operational sections of this specification is not implied. Exposure to the absolute maximum rating conditions for extended period may affect device reliability.

TRUTH TABLE

MODE	CE#	CE2	OE#	WE#	LB#	UB#	I/O OPERATION		SUPPLY CURRENT
							DQ0-DQ7	DQ8-DQ15	
Standby	H	X	X	X	X	X	High - Z	High - Z	I _{SB} , I _{SB1}
	X	L	X	X	X	X	High - Z	High - Z	
	X	X	X	X	H	H	High - Z	High - Z	
Output Disable	L	H	H	H	L	X	High - Z	High - Z	I _{CC} , I _{CC1}
	L	H	H	H	X	L	High - Z	High - Z	
Read	L	H	L	H	L	H	D _{OUT}	High - Z	I _{CC} , I _{CC1}
	L	H	L	H	H	L	High - Z	D _{OUT}	
	L	H	L	H	L	L	D _{OUT}	D _{OUT}	
Write	L	H	X	L	L	H	D _{IN}	High - Z	I _{CC} , I _{CC1}
	L	H	X	L	H	L	High - Z	D _{IN}	
	L	H	X	L	L	L	D _{IN}	D _{IN}	

Note: H = V_{IH}, L = V_{IL}, X = Don't care.

DC ELECTRICAL CHARACTERISTICS

PARAMETER	SYMBOL	TEST CONDITION	MIN.	TYP. ^{*4}	MAX.	UNIT		
Supply Voltage	V _{CC}		2.7	3.0	3.6	V		
Input High Voltage	V _{IH} ^{*1}		2.2	-	V _{CC} +0.3	V		
Input Low Voltage	V _{IL} ^{*2}		-0.2	-	0.6	V		
Input Leakage Current	I _{LI}	V _{CC} □ V _{IN} □ V _{SS}	-1	-	1	μA		
Output Leakage Current	I _{LO}	V _{CC} □ V _{OUT} □ V _{SS} , Output Disabled	-1	-	1	μA		
Output High Voltage	V _{OH}	I _{OH} = -1mA	2.2	2.7	-	V		
Output Low Voltage	V _{OL}	I _{OL} = 2mA	-	-	0.4	V		
Average Operating Power supply Current	I _{CC}	Cycle time = Min. CE# = V _{IL} and CE2 = V _{IH} I _{I/O} = 0mA Other pins at V _{IL} or V _{IH}	-55	-	30	40	mA	
			-70	-	20	30	mA	
	I _{CC1}	Cycle time = 1μs CE# ≤ 0.2V and CE2 ≥ V _{CC} -0.2V I _{I/O} = 0mA Other pins at 0.2V or V _{CC} -0.2V	-	4	8	mA		
Standby Power Supply Current	I _{SB}	CE# = V _{IH} or CE2 = V _{IL} Other pins at V _{IL} or V _{IH}	-	0.15	1	mA		
	I _{SB1}	CE# □ V _{CC} -0.2V or CE2 ≤ 0.2V Other pins at 0.2V or V _{CC} -0.2V	*SLI ^{*5}	25°C	-	1.5	5	μA
				40°C	-	1.5	5	μA
					-			
	SLI		-	1.5	20	μA		

Notes:

- V_{IH}(max) = V_{CC} + 3.0V for pulse width less than 10ns.
- V_{IL}(min) = V_{SS} - 3.0V for pulse width less than 10ns.
- Over/Undershoot specifications are characterized, not 100% tested.
- Typical values are included for reference only and are not guaranteed or tested.
Typical values are measured at V_{CC} = V_{CC}(TYP.) and T_A = 25°C
- This parameter is measured at V_{CC} = 3.0V

CAPACITANCE ($T_A = 25^\circ\text{C}$, $f = 1.0\text{MHz}$)

PARAMETER	SYMBOL	MIN.	MAX	UNIT
Input Capacitance	C_{IN}	-	6	pF
Input/Output Capacitance	$C_{I/O}$	-	8	pF

Note : These parameters are guaranteed by device characterization, but not production tested.

AC TEST CONDITIONS

Input Pulse Levels	0.2V to $V_{CC} - 0.2V$
Input Rise and Fall Times	3ns
Input and Output Timing Reference Levels	1.5V
Output Load	$C_L = 30\text{pF} + 1\text{TTL}$, $I_{OH}/I_{OL} = -1\text{mA}/2\text{mA}$

AC ELECTRICAL CHARACTERISTICS

(1) READ CYCLE

PARAMETER	SYM.	AS6C8016-55TIN		UNIT
		MIN.	MAX.	
Read Cycle Time	t_{RC}	55	-	ns
Address Access Time	t_{AA}	-	55	ns
Chip Enable Access Time	t_{ACE}	-	55	ns
Output Enable Access Time	t_{OE}	-	30	ns
Chip Enable to Output in Low-Z	t_{CLZ}^*	10	-	ns
Output Enable to Output in Low-Z	t_{OLZ}^*	5	-	ns
Chip Disable to Output in High-Z	t_{CHZ}^*	-	20	ns
Output Disable to Output in High-Z	t_{OHZ}^*	-	20	ns
Output Hold from Address Change	t_{OH}	10	-	ns
LB#, UB# Access Time	t_{BA}	-	55	ns
LB#, UB# to High-Z Output	t_{BHZ}^*	-	25	ns
LB#, UB# to Low-Z Output	t_{BLZ}^*	10	-	ns

(2) WRITE CYCLE

PARAMETER	SYM.	AS6C8016-55TIN		UNIT
		MIN.	MAX.	
Write Cycle Time	t_{WC}	55	-	ns
Address Valid to End of Write	t_{AW}	50	-	ns
Chip Enable to End of Write	t_{CW}	50	-	ns
Address Set-up Time	t_{AS}	0	-	ns
Write Pulse Width	t_{WP}	45	-	ns
Write Recovery Time	t_{WR}	0	-	ns
Data to Write Time Overlap	t_{DW}	25	-	ns
Data Hold from End of Write Time	t_{DH}	0	-	ns
Output Active from End of Write	t_{OW}^*	5	-	ns
Write to Output in High-Z	t_{WHZ}^*	-	20	ns
LB#, UB# Valid to End of Write	t_{BW}	45	-	ns

*These parameters are guaranteed by device characterization, but not production tested.

TIMING WAVEFORMS

READ CYCLE 1 (Address Controlled) (1,2)

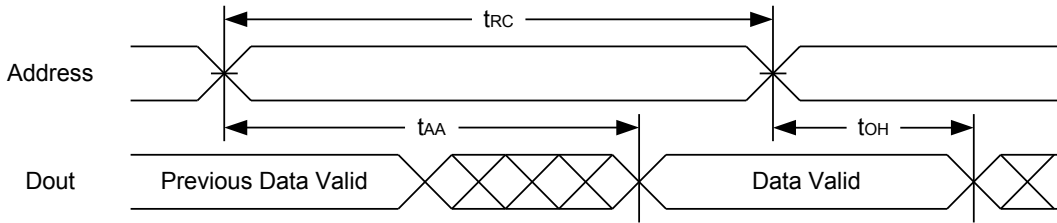

READ CYCLE 2 (CE# and CE2 and OE# Controlled) (1,3,4,5)

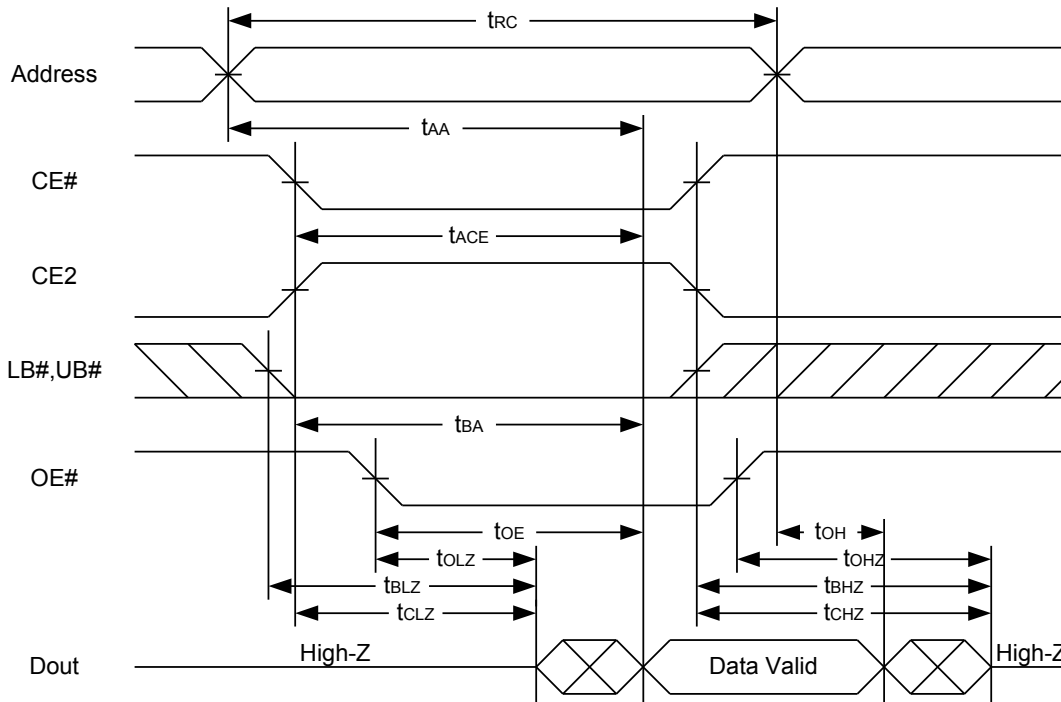

Notes :

1. WE# is high for read cycle.
2. Device is continuously selected OE# = low, CE# = low, CE2 = high, LB# or UB# = low.
3. Address must be valid prior to or coincident with CE# = low, CE2 = high, LB# or UB# = low transition; otherwise t_{AA} is the limiting parameter.
4. t_{CLZ} , t_{BLZ} , t_{OLZ} , t_{CHZ} , t_{BHZ} and t_{OHZ} are specified with $C_L = 5\text{pF}$. Transition is measured $\pm 500\text{mV}$ from steady state.
5. At any given temperature and voltage condition, t_{CHZ} is less than t_{CLZ} , t_{BHZ} is less than t_{BLZ} , t_{OHZ} is less than t_{OLZ} .

WRITE CYCLE 1 (WE# Controlled) (1,2,3,5,6)

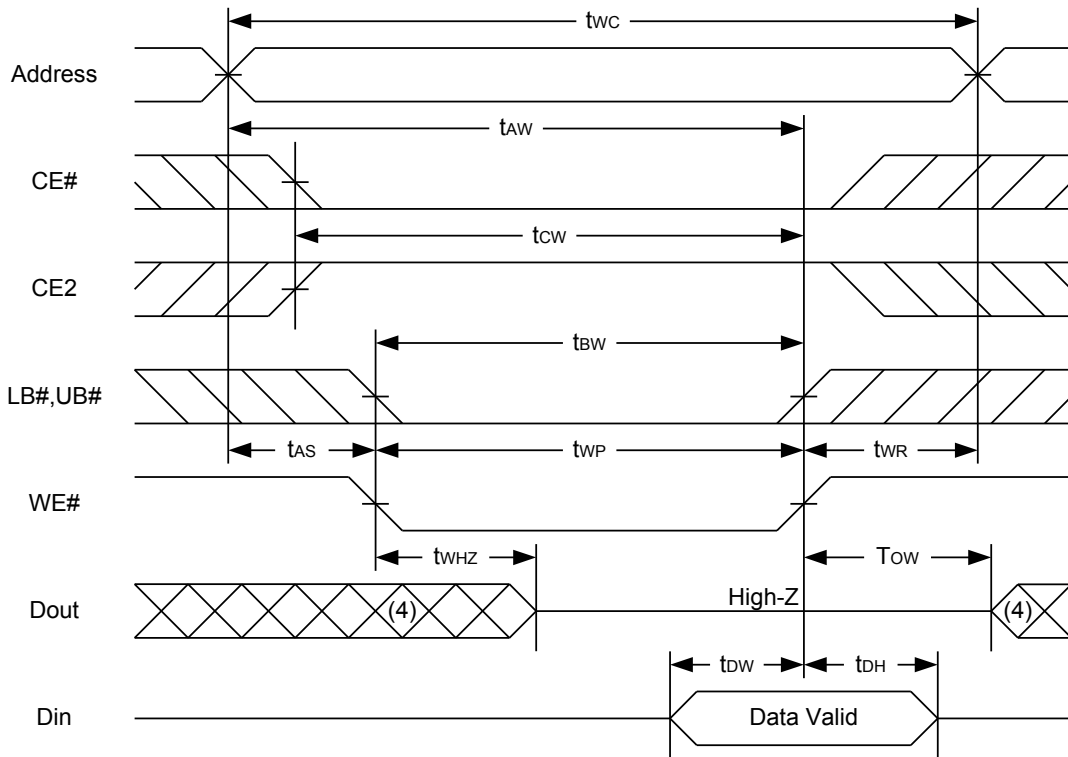

WRITE CYCLE 2 (CE# and CE2 Controlled) (1,2,5,6)

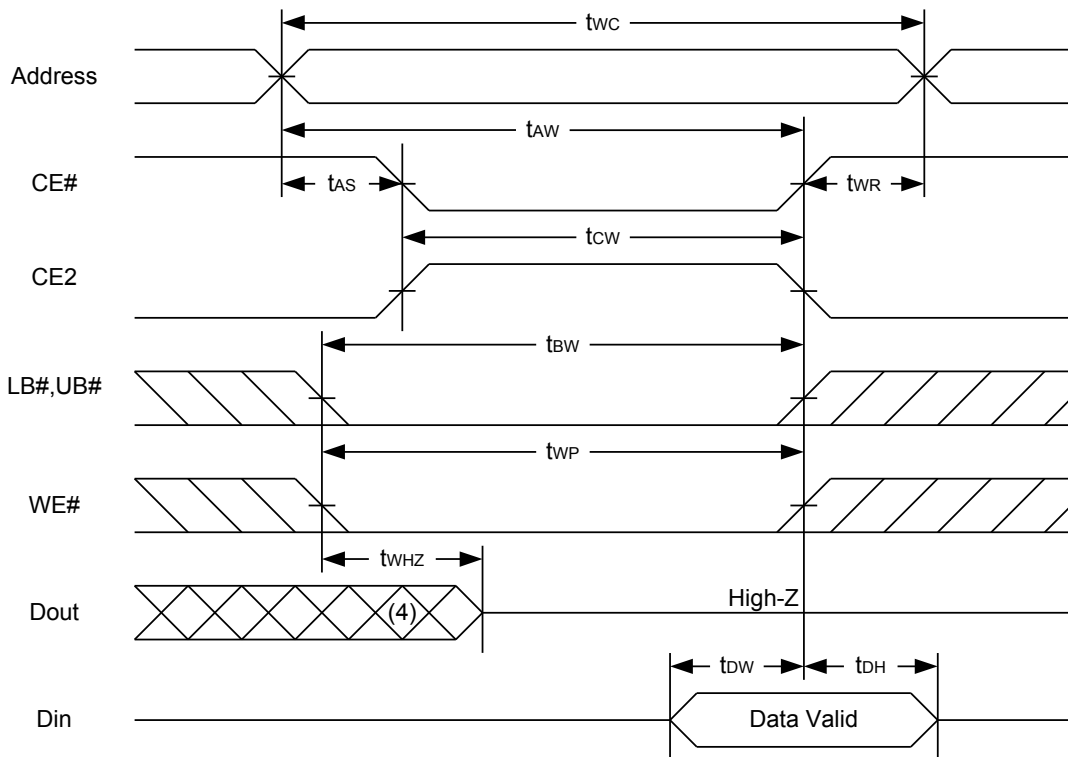

WRITE CYCLE 3 (LB#,UB# Controlled) (1,2,5,6)

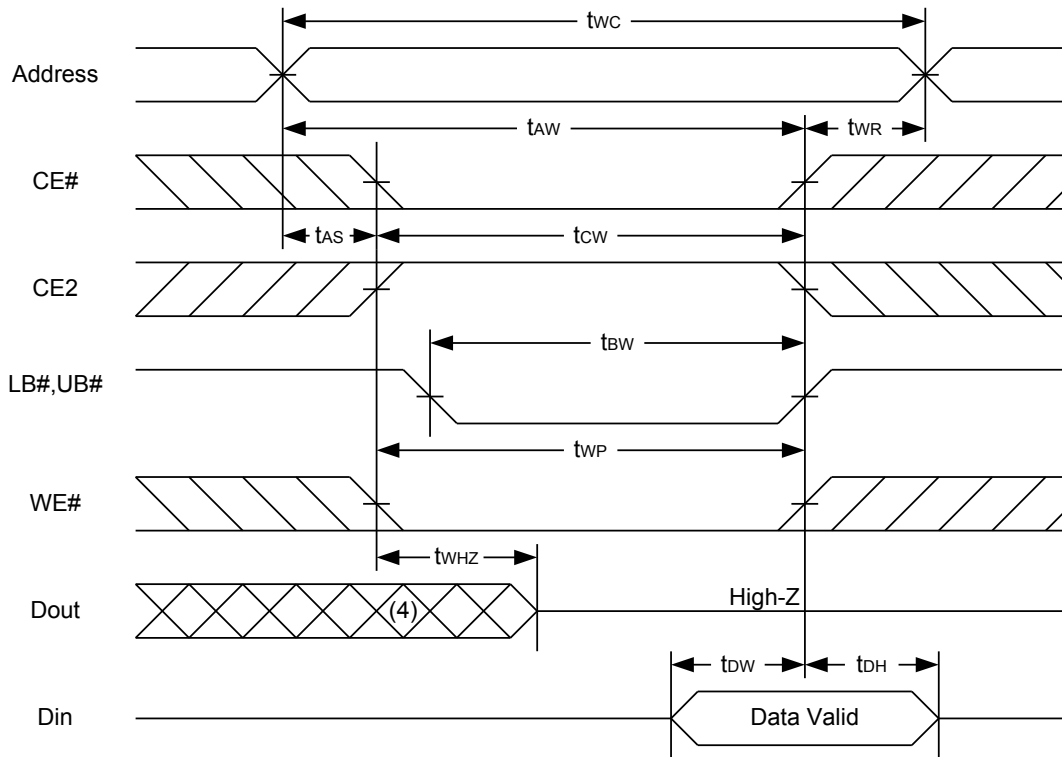

Notes :

1. WE#, CE#, LB#, UB# must be high or CE2 must be low during all address transitions.
2. A write occurs during the overlap of a low CE#, high CE2, low WE#, LB# or UB# = low.
3. During a WE# controlled write cycle with OE# low, t_{WP} must be greater than $t_{WHZ} + t_{DW}$ to allow the drivers to turn off and data to be placed on the bus.
4. During this period, I/O pins are in the output state, and input signals must not be applied.
5. If the CE#, LB#, UB# low transition and CE2 high transition occurs simultaneously with or after WE# low transition, the outputs remain in a high impedance state.
6. t_{ow} and t_{whz} are specified with $C_L = 5pF$. Transition is measured $\pm 500mV$ from steady state.

DATA RETENTION CHARACTERISTICS

PARAMETER	SYMBOL	TEST CONDITION	MIN.	TYP.	MAX.	UNIT		
VCC for Data Retention	V _{DR}	CE# □ V _{CC} - 0.2V or CE2 ≤ 0.2V	1.2	-	3.6	V		
Data Retention Current	I _{DR}	V _{CC} = 1.2V CE# □ V _{CC} -0.2V or CE2 ≤ 0.2V Other pins at 0.2V or V _{CC} -0.2V	SLI	25°C	-	1	3	μA
			SLI	40°C	-	1	3	μA
			SLI	-	-	1	20	μA
Chip Disable to Data Retention Time	t _{CDR}	See Data Retention Waveforms (below)	0	-	-	ns		
Recovery Time	t _R		t _{RC} *	-	-	ns		

t_{RC}* = Read Cycle Time

DATA RETENTION WAVEFORM

Low Vcc Data Retention Waveform (1) (CE# controlled)

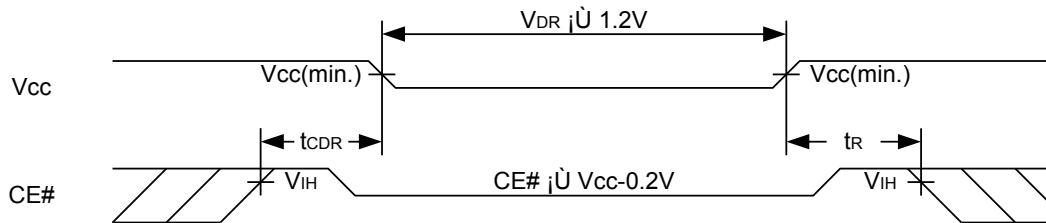

Low Vcc Data Retention Waveform (2) (CE2 controlled)

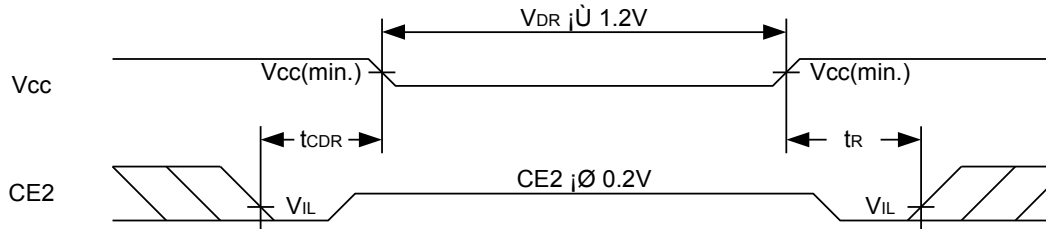

Low Vcc Data Retention Waveform (3) (LB#, UB# controlled)

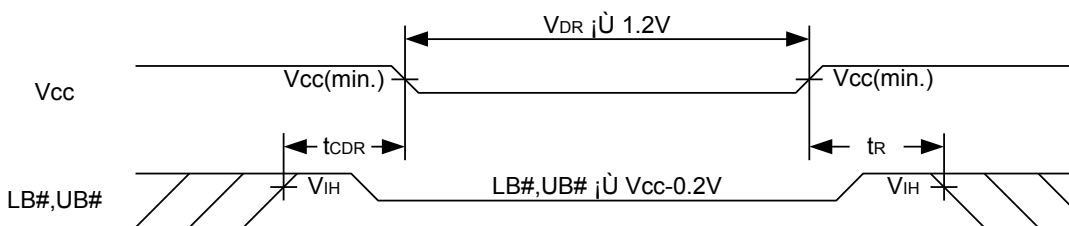

PACKAGE OUTLINE DIMENSION

48-pin 12mm x 20mm TSOP-I Package Outline Dimension

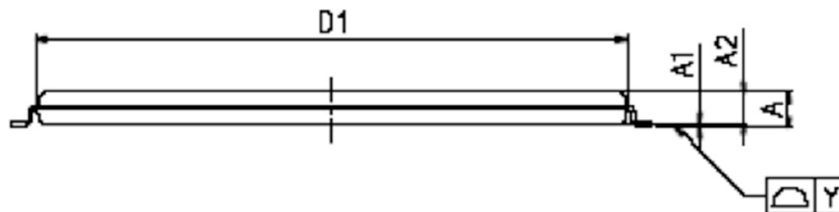
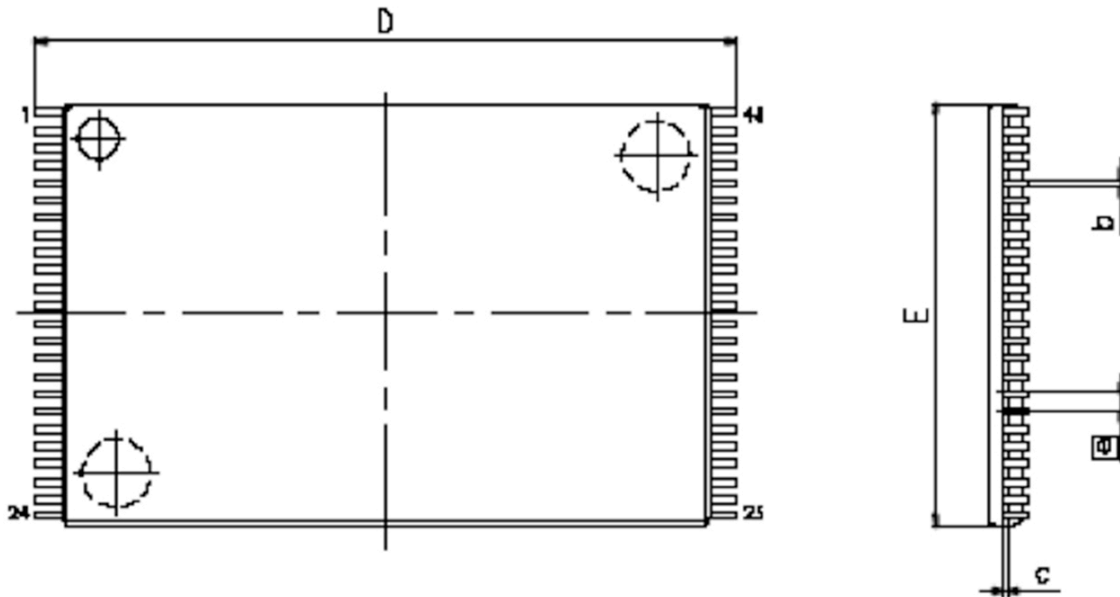

VARIATIONS (ALL DIMENSIONS SHOWN IN MM)

SYMBOLS	MIN.	NOM.	MAX
A	-	-	1.20
A1	0.05	-	0.15
A2	0.95	1.00	1.05
b	0.17	0.22	0.27
c	0.10	-	0.21
△ D	19.80	20.00	20.20
△ □1	18.30	18.40	18.50
△ E	11.90	12.00	12.10
⊕	0.50 BASIC		
L	0.50	0.60	0.70
△ L1	-	0.80	-
△ Y	-	-	0.10
△ θ	0°	-	5°

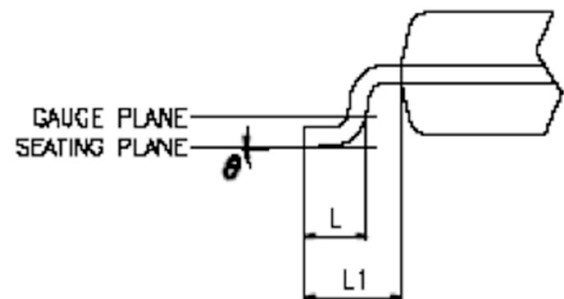

NOTES:

- 1 JEDEC OUTLINE : MO-142 DD
2. PROFILE TOLERANCE ZONES FOR D1 AND E DO NOT INCLUDE MOLD PROTRUSION. ALLOWABLE MOLD PROTRUSION ON E IS 0.15mm PER SIDE AND ON D1 IS 0.25mm PER SIDE.
3. DIMENSION b DOES NOT INCLUDE DAMBAR PROTRUSION ALLOWABLE DAMBAR PROTRUSION SHALL BE 0.08mm TOTAL IN EXCESS OF THE b DIMENSION AT MAXIMUM MATERIAL CONDITION DAMBAR CANNOT BE LOCATED ON THE LOWER RADIUS OR THE FOOT.

PART NUMBERING SYSTEM

AS6C	8016	55	T	I	N
SRAM	8M=512K x 16	Speed=55 ns	T = 48pin TSOP I	I=Industrial (-40°C~85°C)	Indicates Pb and Halogen Free



Alliance Memory, Inc.
 511 Taylor Way,
 San Carlos, CA 94070
 Tel: 650-610-6800
 Fax: 650-620-9211
www.alliancememory.com

Copyright © Alliance Memory
 All Rights Reserved

© Copyright 2007 Alliance Memory, Inc. All rights reserved. Our three-point logo, our name and Intelliwatt are trademarks or registered trademarks of Alliance. All other brand and product names may be the trademarks of their respective companies. Alliance reserves the right to make changes to this document and its products at any time without notice. Alliance assumes no responsibility for any errors that may appear in this document. The data contained herein represents Alliance's best data and/or estimates at the time of issuance. Alliance reserves the right to change or correct this data at any time, without notice. If the product described herein is under development, significant changes to these specifications are possible. The information in this product data sheet is intended to be general descriptive information for potential customers and users, and is not intended to operate as, or provide, any guarantee or warrantee to any user or customer. Alliance does not assume any responsibility or liability arising out of the application or use of any product described herein, and disclaims any express or implied warranties related to the sale and/or use of Alliance products including liability or warranties related to fitness for a particular purpose, merchantability, or infringement of any intellectual property rights, except as express agreed to in Alliance's Terms and Conditions of Sale (which are available from Alliance). All sales of Alliance products are made exclusively according to Alliance's Terms and Conditions of Sale. The purchase of products from Alliance does not convey a license under any patent rights, copyrights; mask works rights, trademarks, or any other intellectual property rights of Alliance or third parties. Alliance does not authorize its products for use as critical components in life-supporting systems where a malfunction or failure may reasonably be expected to result in significant injury to the user, and the inclusion of Alliance products in such life-supporting systems implies that the manufacturer assumes all risk of such use and agrees to indemnify Alliance against all claims arising from such use.



**Стандарт
Электрон
Связь**

Мы молодая и активно развивающаяся компания в области поставок электронных компонентов. Мы поставляем электронные компоненты отечественного и импортного производства напрямую от производителей и с крупнейших складов мира.

Благодаря сотрудничеству с мировыми поставщиками мы осуществляем комплексные и плановые поставки широчайшего спектра электронных компонентов.

Собственная эффективная логистика и склад в обеспечивает надежную поставку продукции в точно указанные сроки по всей России.

Мы осуществляем техническую поддержку нашим клиентам и предпродажную проверку качества продукции. На все поставляемые продукты мы предоставляем гарантию .

Осуществляем поставки продукции под контролем ВП МО РФ на предприятия военно-промышленного комплекса России , а также работаем в рамках 275 ФЗ с открытием отдельных счетов в уполномоченном банке. Система менеджмента качества компании соответствует требованиям ГОСТ ISO 9001.

Минимальные сроки поставки, гибкие цены, неограниченный ассортимент и индивидуальный подход к клиентам являются основой для выстраивания долгосрочного и эффективного сотрудничества с предприятиями радиоэлектронной промышленности, предприятиями ВПК и научно-исследовательскими институтами России.

С нами вы становитесь еще успешнее!

Наши контакты:

Телефон: +7 812 627 14 35

Электронная почта: sales@st-electron.ru

Адрес: 198099, Санкт-Петербург,
Промышленная ул, дом № 19, литера Н,
помещение 100-Н Офис 331