



**8-Pin SOIC/MSOP/TSSOP/DIP
Evaluation Board
User's Guide**

Note the following details of the code protection feature on Microchip devices:

- Microchip products meet the specification contained in their particular Microchip Data Sheet.
- Microchip believes that its family of products is one of the most secure families of its kind on the market today, when used in the intended manner and under normal conditions.
- There are dishonest and possibly illegal methods used to breach the code protection feature. All of these methods, to our knowledge, require using the Microchip products in a manner outside the operating specifications contained in Microchip's Data Sheets. Most likely, the person doing so is engaged in theft of intellectual property.
- Microchip is willing to work with the customer who is concerned about the integrity of their code.
- Neither Microchip nor any other semiconductor manufacturer can guarantee the security of their code. Code protection does not mean that we are guaranteeing the product as "unbreakable."

Code protection is constantly evolving. We at Microchip are committed to continuously improving the code protection features of our products. Attempts to break Microchip's code protection feature may be a violation of the Digital Millennium Copyright Act. If such acts allow unauthorized access to your software or other copyrighted work, you may have a right to sue for relief under that Act.

Information contained in this publication regarding device applications and the like is provided only for your convenience and may be superseded by updates. It is your responsibility to ensure that your application meets with your specifications. MICROCHIP MAKES NO REPRESENTATIONS OR WARRANTIES OF ANY KIND WHETHER EXPRESS OR IMPLIED, WRITTEN OR ORAL, STATUTORY OR OTHERWISE, RELATED TO THE INFORMATION, INCLUDING BUT NOT LIMITED TO ITS CONDITION, QUALITY, PERFORMANCE, MERCHANTABILITY OR FITNESS FOR PURPOSE. Microchip disclaims all liability arising from this information and its use. Use of Microchip's products as critical components in life support systems is not authorized except with express written approval by Microchip. No licenses are conveyed, implicitly or otherwise, under any Microchip intellectual property rights.

Trademarks

The Microchip name and logo, the Microchip logo, Accuron, dsPIC, KEELOQ, microID, MPLAB, PIC, PICmicro, PICSTART, PRO MATE, PowerSmart, rfPIC, and SmartShunt are registered trademarks of Microchip Technology Incorporated in the U.S.A. and other countries.

AmpLab, FilterLab, Migratable Memory, MXDEV, MXLAB, PICMASTER, SEEVAL, SmartSensor and The Embedded Control Solutions Company are registered trademarks of Microchip Technology Incorporated in the U.S.A.

Analog-for-the-Digital Age, Application Maestro, dsPICDEM, dsPICDEM.net, dsPICworks, ECAN, ECONOMONITOR, FanSense, FlexROM, fuzzyLAB, In-Circuit Serial Programming, ICSP, ICEPIC, MPASM, MPLIB, MPLINK, MPSIM, PICKit, PICDEM, PICDEM.net, PICLAB, PICTail, PowerCal, PowerInfo, PowerMate, PowerTool, rfLAB, rfPICDEM, Select Mode, Smart Serial, SmartTel, Total Endurance and WiperLock are trademarks of Microchip Technology Incorporated in the U.S.A. and other countries.

SQTP is a service mark of Microchip Technology Incorporated in the U.S.A.

All other trademarks mentioned herein are property of their respective companies.

© 2005, Microchip Technology Incorporated, Printed in the U.S.A., All Rights Reserved.

 Printed on recycled paper.

**QUALITY MANAGEMENT SYSTEM
CERTIFIED BY DNV
== ISO/TS 16949:2002 ==**

Microchip received ISO/TS-16949:2002 quality system certification for its worldwide headquarters, design and wafer fabrication facilities in Chandler and Tempe, Arizona and Mountain View, California in October 2003. The Company's quality system processes and procedures are for its PICmicro® 8-bit MCUs, KEELOQ® code hopping devices, Serial EEPROMs, microperipherals, nonvolatile memory and analog products. In addition, Microchip's quality system for the design and manufacture of development systems is ISO 9001:2000 certified.



8-PIN SOIC/MSOP/TSSOP/DIP EVALUATION BOARD USER'S GUIDE

Table of Contents

Preface	1
Chapter 1. Product Overview	5
1.1 Introduction	5
1.2 What is the 8-Pin SOIC/MSOP/TSSOP/DIP Evaluation Board?	5
1.3 What the 8-Pin SOIC/MSOP/TSSOP/DIP Evaluation Board Kit Includes	5
Chapter 2. Installation and Operation	7
2.1 Introduction	7
2.2 Features	7
2.3 Getting Started	8
2.4 8-Pin SOIC/MSOP/TSSOP/DIP Evaluation Board Description	12
Appendix A. Schematic and Layouts	19
A.1 Introduction	19
A.2 Schematics and PCB Layout	19
Appendix B. Bill of Materials (BOM)	27
Appendix C. Microchip Analog and Interface Device Compatability	29
C.1 Introduction	29
Appendix D. Rev. 1 PCB Errata	35
D.1 Introduction	35
D.2 Rev 1 PCB Issues	35
Worldwide Sales and Service	38

8-Pin SOIC/MSOP/TSSOP/DIP Evaluation Board User's Guide

NOTES:



MICROCHIP

8-PIN SOIC/MSOP/TSSOP/DIP EVALUATION BOARD USER'S GUIDE

Preface

NOTICE TO CUSTOMERS

All documentation becomes dated, and this manual is no exception. Microchip tools and documentation are constantly evolving to meet customer needs, so some actual dialogs and/or tool descriptions may differ from those in this document. Please refer to our web site (www.microchip.com) to obtain the latest documentation available.

Documents are identified with a "DS" number. This number is located on the bottom of each page, in front of the page number. The numbering convention for the DS number is "DSXXXXXA", where "XXXXX" is the document number and "A" is the revision level of the document.

For the most up-to-date information on development tools, see the MPLAB® IDE on-line help. Select the Help menu, and then Topics to open a list of available on-line help files.

INTRODUCTION

This chapter contains general information that will be useful to know before using the 8-Pin SOIC/MSOP/TSSOP/DIP Evaluation Board. Items discussed in this chapter include:

- Document Layout
- Conventions Used in this Guide
- Recommended Reading
- The Microchip Web Site
- Customer Support
- Document Revision History

DOCUMENT LAYOUT

This document describes how to use the 8-Pin SOIC/MSOP/TSSOP/DIP Evaluation Board. The manual layout is as follows:

- **Chapter 1. "Product Overview"** – Important information about the 8-Pin SOIC/MSOP/TSSOP/DIP Evaluation Board.
- **Chapter 2. "Installation and Operation"** – Includes instructions on how to get started with this evaluation board.
- **Appendix A. "Schematic and Layouts"** – Shows the schematic and layout diagrams for the 8-Pin SOIC/MSOP/TSSOP/DIP Evaluation Board.
- **Appendix B. "Bill of Materials (BOM)"** – Lists the parts used to build the 8-Pin SOIC/MSOP/TSSOP/DIP Evaluation Board.
- **Appendix C. "Microchip Analog and Interface Device Compatibility"** – Documents the Microchip Analog & Interface devices that are footprint compatible with this PCB.
- **Appendix D. "Rev. 1 PCB Errata"** – Describes the PCB Errata for the Revision 1 board.

8-Pin SOIC/MSOP/TSSOP/DIP Evaluation Board User's Guide

CONVENTIONS USED IN THIS GUIDE

This manual uses the following documentation conventions:

DOCUMENTATION CONVENTIONS

Description	Represents	Examples
Arial font:		
Italic characters	Referenced books	<i>MPLAB[®] IDE User's Guide</i>
	Emphasized text	...is the <i>only</i> compiler...

RECOMMENDED READING

This blank PCB is generic and can be used with any Microchip device that is offered in one of the following 8-pin packages:

- SOIC
- DIP
- MSOP
- TSSOP

For more information regarding devices available in these 8-pin packages, please refer to the Microchip web site at www.microchip.com.

THE MICROCHIP WEB SITE

Microchip provides online support via our web site at www.microchip.com. This web site is used as a means to make files and information easily available to customers. Accessible by using your favorite Internet browser, the web site contains the following information:

- **Product Support** – Data sheets and errata, application notes and sample programs, design resources, user's guides and hardware support documents, latest software releases and archived software
- **General Technical Support** – Frequently Asked Questions (FAQs), technical support requests, online discussion groups, Microchip consultant program member listing
- **Business of Microchip** – Product selector and ordering guides, latest Microchip press releases, listing of seminars and events, listings of Microchip sales offices, distributors and factory representatives

CUSTOMER SUPPORT

Users of Microchip products can receive assistance through several channels:

- Distributor or Representative
- Local Sales Office
- Field Application Engineer (FAE)
- Technical Support
- Development Systems Information Line

Customers should contact their distributor, representative or field application engineer (FAE) for support. Local sales offices are also available to help customers. A listing of sales offices and locations is included in the back of this document.

Technical support is available through the web site at: <http://support.microchip.com>

In addition, there is a Development Systems Information Line which lists the latest versions of Microchip's development systems software products. This line also provides information on how customers can receive currently available upgrade kits.

The Development Systems Information Line numbers are:

1-800-755-2345 – United States and most of Canada

1-480-792-7302 – Other International Locations

DOCUMENT REVISION HISTORY

Revision A (March 2005)

- Initial Release of this Document.

8-Pin SOIC/MSOP/TSSOP/DIP Evaluation Board User's Guide

NOTES:



8-PIN SOIC/MSOP/TSSOP/DIP EVALUATION BOARD USER'S GUIDE

Chapter 1. Product Overview

1.1 INTRODUCTION

This chapter provides an overview of the 8-Pin SOIC/MSOP/TSSOP/DIP Evaluation Board and covers the following topics:

- What is the 8-Pin SOIC/MSOP/TSSOP/DIP Evaluation Board?
- What the 8-Pin SOIC/MSOP/TSSOP/DIP Evaluation Board kit includes

1.2 WHAT IS THE 8-PIN SOIC/MSOP/TSSOP/DIP EVALUATION BOARD?

The 8-Pin SOIC/MSOP/TSSOP/DIP Evaluation Board allows the system designer to quickly evaluate the operation of Microchip Technology's devices in any of the following 8-pin packages:

- SOIC
- DIP
- MSOP
- TSSOP

Some of the Microchip family of devices that can be evaluated in the PCB include:

- A/D Converters (ADCs) (ADCs)
- Battery Chargers
- Comparators
- D/A Converters (DACs) (DACs)
- DC-to-DC Converters
- Digital Potentiometers (Digi-Pots)
- Fan Controllers
- Integrated Devices
- Interface Devices
- Linear Regulators
- Operational Amplifiers (Op Amps)
- Power MOSFET Drivers
- Programmable Gain Amplifiers (PGAs)s (PGAs)
- Switching Regulators
- Temperature Sensors
- Voltage Supervisors and Voltage Detectors
- PICmicro[®] Microcontrollers

1.3 WHAT THE 8-PIN SOIC/MSOP/TSSOP/DIP EVALUATION BOARD KIT INCLUDES

This 8-Pin SOIC/MSOP/TSSOP/DIP Evaluation Board Kit includes:

- Three 8-Pin SOIC/MSOP/TSSOP/DIP Evaluation Board PCBs
- 8-Pin SOIC/MSOP/TSSOP/DIP Evaluation Board User's Guide (DS51544) (Electronic version on CD)

8-Pin SOIC/MSOP/TSSOP/DIP Evaluation Board User's Guide

NOTES:



8-PIN SOIC/MSOP/TSSOP/DIP EVALUATION BOARD USER'S GUIDE

Chapter 2. Installation and Operation

2.1 INTRODUCTION

This blank Printed Circuit Board (PCB) allows any 8-pin device in the following four package types to be installed:

1. SOIC-8
2. PDIP-8
3. MSOP-8
4. TSSOP-8

This board is generic so that any device may be installed. Refer to the device data sheet, however, for suitability of device evaluation.

As well as the device, other desired passive components (resistors and capacitors) and connection posts may be installed. This allows the board to evaluate a minimum configuration for the device. Also, this allows the device to be easily jumpered into an existing system.

2.2 FEATURES

The 8-Pin SOIC/MSOP/TSSOP/DIP Evaluation Board has the following features:

- Connection terminals may be either through-hole or surface-mount
- Four 8-pin package footprints supported:
 - SOIC
 - DIP
 - MSOP
 - TSSOP
- Footprints for optional passive components for:
 - Power supply filtering
 - Device bypass capacitor
 - Output filtering
 - Output pull-up resistor
 - Output pull-down resistor
 - Output loading resistor
 - Output series resistor
 - Up to four additional passive components
- Silk-screen area to write specifics of implemented circuit (on back of PCB), such as TC1232 4.75V, (to indicate that the device is the TC1232 with the 4.75V trip point)
- PICmicro[®] MCU Baseline Flash Microcontroller Programmer (BFMP) Header
- Can be used for SOIC-8, MSOP-8, TSSOP-8 to DIP-8 converter

2.3 GETTING STARTED

The 8-Pin SOIC/MSOP/TSSOP/DIP Evaluation Board is a blank PCB that allows the user to configure the circuit to the exact requirements. The passive components use the surface-mount 805 package layout.

This evaluation board supports the following Microchip device families:

- A/D Converters (ADCs) (ADCs)
- Battery Chargers
- Comparators
- D/A Converters (DACs) (DACs)
- DC-to-DC Converters
- Digital Potentiometers (Digi-Pots)
- Fan Controllers
- Integrated Devices
- Interface Devices
- Linear Regulators
- Operational Amplifiers (Op Amps)
- Power MOSFET Drivers
- Programmable Gain Amplifiers (PGAs)s (PGAs)
- Switching Regulators
- Temperature Sensors
- Voltage Supervisors and Voltage Detectors
- PICmicro Microcontrollers

Figure 2-1 shows the evaluation board circuit. Pin “n” of each device (U1, U2, U3 and U4) are tied together. These pins are then connected with pad “n” of the PCB (through a circuit). This circuit allows each pin to individually have any of the following: a pull-up resistor, a pull-down resistor, an in-line resistor and/or a loading/filtering capacitor. Device-filtering capacitors are available (C2 and C3), as well as a power supply filtering capacitor (C1).

There may be cases where some additional passive components are desired for the evaluation circuit. The PCB has four 805 footprints that are not connected (labeled P1, P2, P3 and P4) and can easily be jumpered into the desired circuit.

Installation and Operation

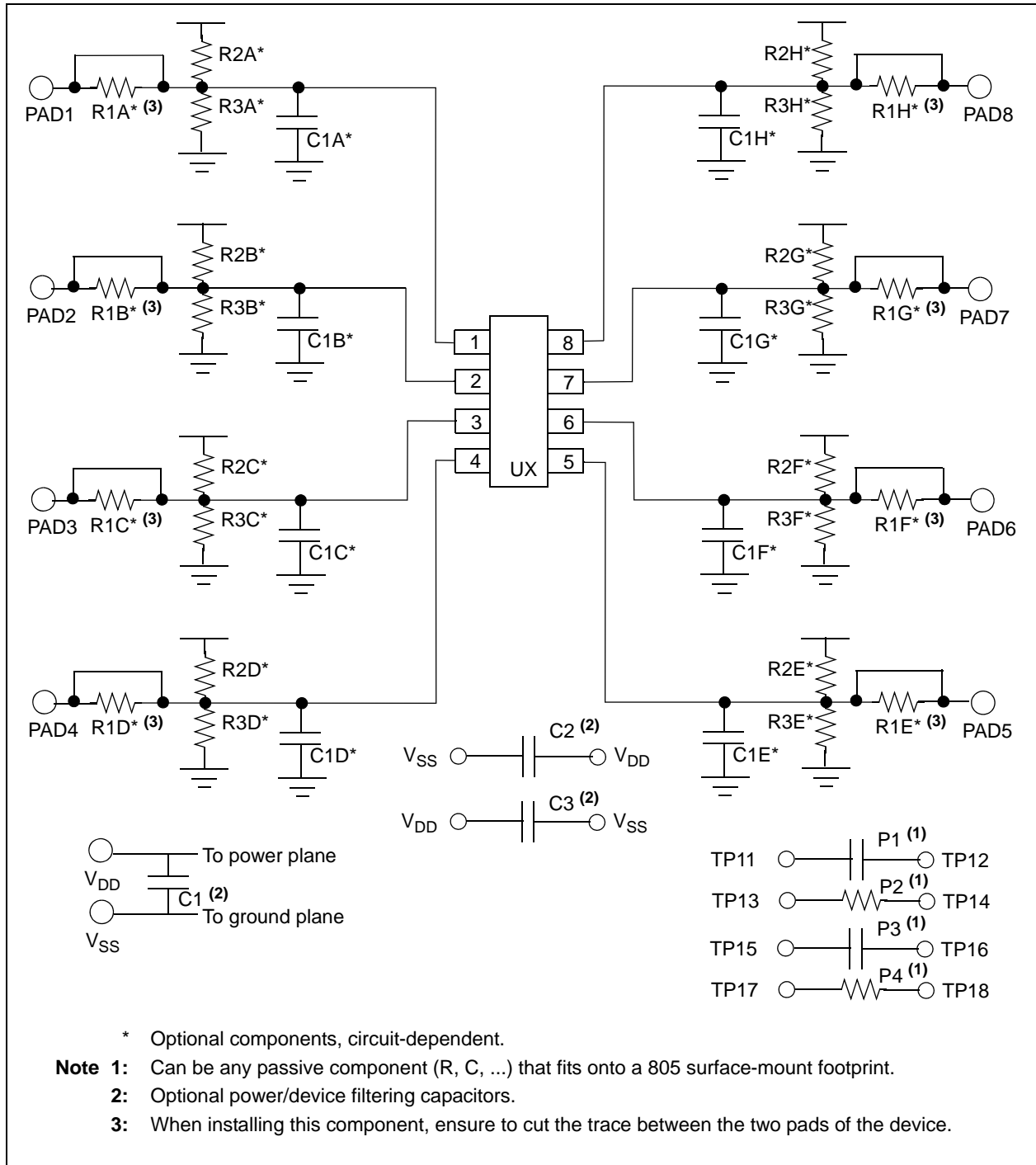

FIGURE 2-1: 8-Pin SOIC/MSOP/TSSOP/DIP Evaluation Board Circuit.

8-Pin SOIC/MSOP/TSSOP/DIP Evaluation Board User's Guide

2.3.1 The Hardware

Figure 2-2 shows the layout of the 8-Pin SOIC/MSOP/TSSOP/DIP Evaluation Board. This is a small four-layer board (1.5" x 2" (38.1 mm x 50.8 mm)). There are ten connection points/pads that can use either through-hole or surface-mount connector posts.

The pad labeled VDD is connected to the PCB power plane, while the pad labeled VSS is connected to the PCB ground plane. All the passive components that are connected to VDD or VSS are connected to either the power plane or ground plane.

The eight remaining PCB pads correspond to the device pins (i.e.; pad 1 connects to pin 1).

Each pad has four passive components associated with them: a pull-up resistor, a pull-down resistor, an in-line resistor and a filtering/load capacitor. The pull-up resistor is always R2X, the pull-down resistor is R3X, the in-line resistor is R1X and the filtering/load capacitor is C1X. The "X" is an alpha character that corresponds to a particular pad (A to H). As an example, Pad 5's pull-up resistor is R2E.

The green area of Figure 2-2 shows the silk-screen on the bottom layer of the PCB. This is where the details of the implemented circuit can be written.

Capacitor C1 is the power supply filtering capacitor.

Capacitors C2 and C3 are bypass capacitors that may be required to be installed, depending on the device selected and the system requirements (such as the noise present on the power supply). Table 2-1 describes the components.

A 6-pin header interface is available that supports the PICmicro MCU Baseline Flash Microcontroller Programmer (BFMP) interface. For additional information, refer to **Section 2.4.5 "Baseline Flash Microcontroller Programmer (BFMP) Interface (Header J1)"**.

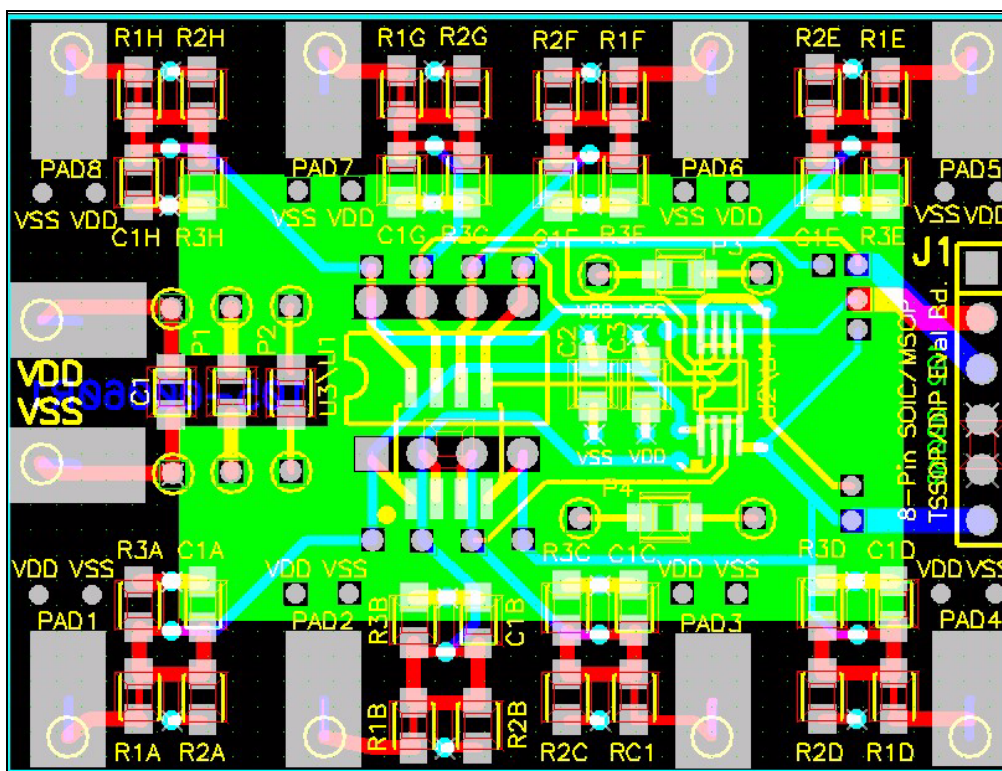

FIGURE 2-2: 8-Pin SOIC/MSOP/TSSOP/DIP Evaluation Board Layout.

TABLE 2-1: OPTIONAL PASSIVE COMPONENTS

Device	Comment
C1	Power supply bypass capacitor
C2, C3	Device Filtering capacitor
C1A, C1B C1C, C1D, C1E, C1F, C1G, C1H	Output filter capacitor
R1A, R1B, R1C, R1D, R1E, R1F, R1G, R1H	In-line resistance of device output
R2A, R2B, R2C, R2D, R2E, R2F, R2G, R2H	Pull-up resistor
R3A, R3B, R3C, R3D, R3E, R3F, R3G, R3H	Pull-down resistor
P1, P2, P3, P4	Optional Passive Components

8-Pin SOIC/MSOP/TSSOP/DIP Evaluation Board User's Guide

2.4 8-PIN SOIC/MSOP/TSSOP/DIP EVALUATION BOARD DESCRIPTION

The 8-Pin SOIC/MSOP/TSSOP/DIP Evaluation Board PCB is designed to be flexible in the type of device evaluation that can be implemented.

The following sections describe each element of this evaluation board in further detail. Refer to Figure 2-3.

2.4.1 Power and Ground

The 8-Pin SOIC/MSOP/TSSOP/DIP Evaluation Board has a VDD Pad and a VSS pad. These pads can have connection posts installed that allows easy connection to the power (V_{DD}) and ground (V_{SS}) planes. The layout allows either through-hole or surface-mount connectors.

The power and ground planes are connected to the appropriate passive components on the PCB (such as power plane to R2X and ground plane to R3X and C1X).

2.4.2 PCB PADS

For each package pin (pins 1 to 8), there is a PCB pad (pads 1 to 8). The device will have some power pins (V_{DD}) and some ground pins (V_{SS}). To ease connections on the PCB, vias to the power and ground plane have been installed close to each PCB pad. This allows any pad to be connected to the power or ground plane, so when power is connected to the VDD and VSS pads, the power is connected to the appropriate device pin.

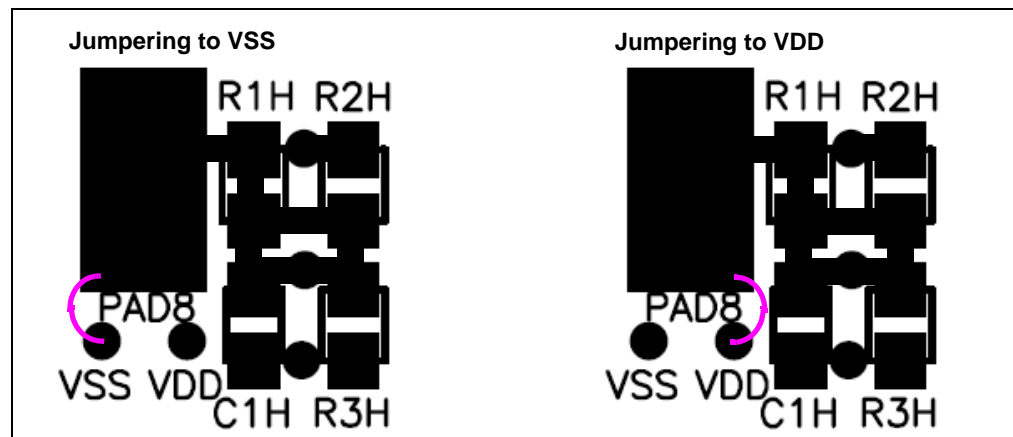

FIGURE 2-3: *Jumpering the PCB pad to either VDD or VSS.*

Revision 1 of this PCB has an issue that these vias are not connected to the desired power and ground planes (they are open). For additional information, refer to **Appendix D. "Rev. 1 PCB Errata"**.

2.4.3 Passive Components (R1X, R2X, R3X, C1X, R1, R2, C1, C2, C3, P1, P2, P3 and P4)

The footprints for these components are present to allow maximum flexibility in the use of this PCB to evaluate a wide range of SOT-23-3 devices. The purpose of these components may vary depending on the device under evaluation and how it is to be used in the desired circuit. Refer to the device data sheet for the recommended components that should be used when evaluating that device.

- Component R1X allows an in-line resistor that can be installed between the device pin and the PCB pad. This may be required when interfacing this PCB to other circuits
- Component R2X allows a pull-up resistor to be installed for the device pin
- Component R3X allows a pull-down resistor to be installed for the device pin
- Component C1X allows a capacitive load/filter to be installed for the device pin
- Component C1 allows a power supply filtering capacitor to be installed
- Components C2 and C3 allows a device filtering capacitor to be installed
- Components P1, P2, P3, and P4 are not connected and give a footprint (805 surface-mount) for a passive component (resistor, capacitor, etc.) to be installed and jumpered into the PCB circuit. This allows for the evaluation of some simple device circuits to be implemented on this PCB

2.4.4 Installing Resistor R1X

Resistor R1X is shorted by default. Therefore, if resistor R1X is to be installed, the trace across the component must be cut before it is installed (see Figure 2-4).

While evaluating a device, it may be desirable to see the signals on both sides of this resistor. A test point is available so that both signals may be monitored. This test point is the avenue between components R3X and C1X (see Figure 2-4).

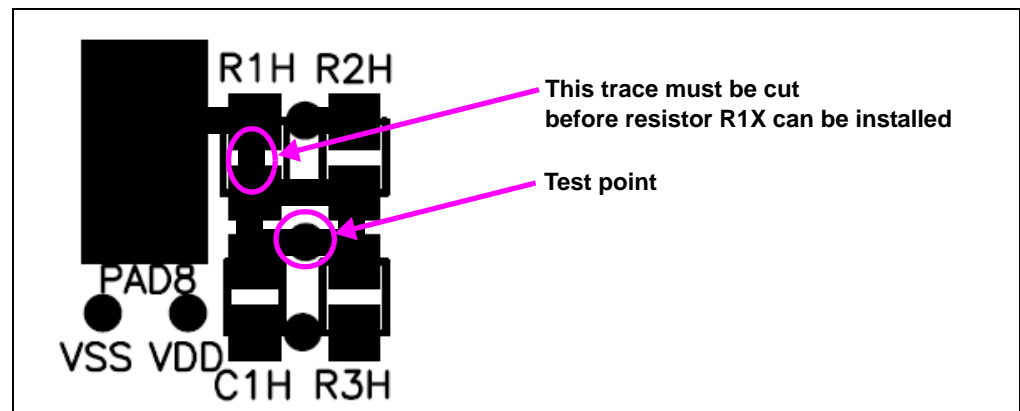

FIGURE 2-4: Test point when resistor R1X is installed.

8-Pin SOIC/MSOP/TSSOP/DIP Evaluation Board User's Guide

2.4.5 Baseline Flash Microcontroller Programmer (BFMP) Interface (Header J1)

The BFMP interface allows a PICmicro MCU device to be programmed with programmers that support this interface, such as the BFMP programmer (part number PG164101).

The PCB supports two device pinouts. The default pinout already has the traces connected to the appropriate PICmicro MCU pins. The optional pinout requires three PCB traces to be cut and then three connections to be made (see Figure 2-5).

TABLE 2-2: BFMP HEADER SIGNALS AND PICMICRO MCU PINS

BFMP Header Signal	Pin Number		Comment
	Default Pinout	Optional Pinout ⁽¹⁾	
CLK	6	4	ICSP™ Clock
DT	7	5	ICSP Data
VPP	4	8	

Note 1: Requires PCB traces to be cut and then jumpered.

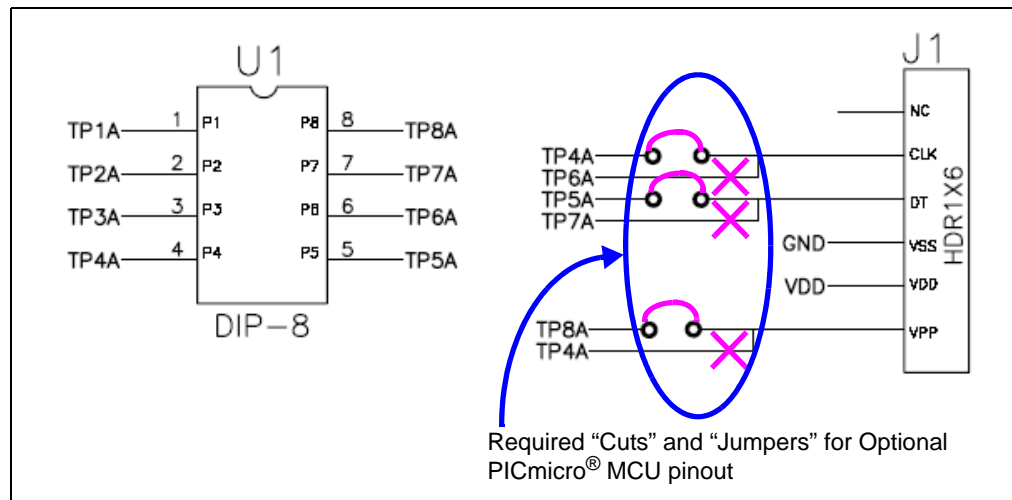

FIGURE 2-5: BFMP Header and Connections

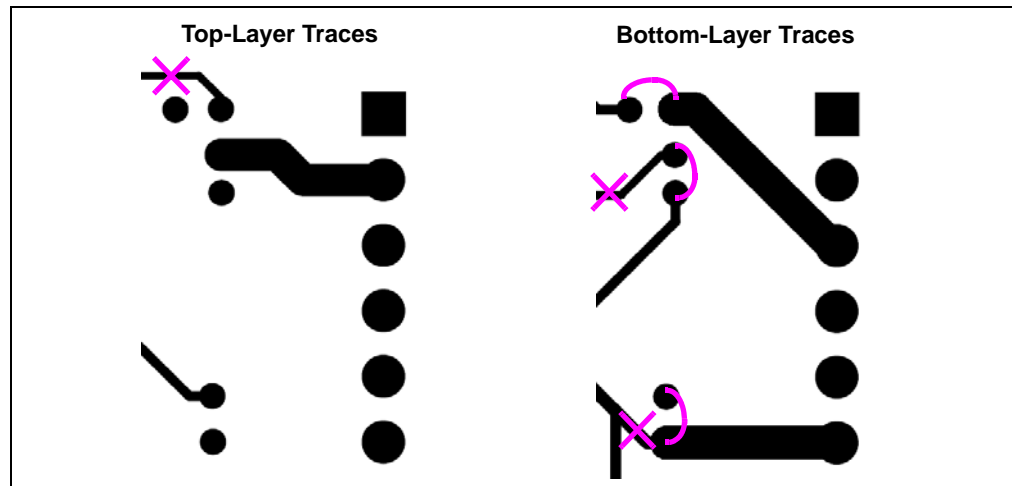

FIGURE 2-6: PCB Traces (Top and Bottom Layers).

2.4.6 The PCB as a SOIC-8, MSOP-8, or TSSOP-8 to DIP-8 Socket Converter

There may be occasions when it is desirable to convert the footprint of the device to that of a DIP package. This allows the device to be installed into an existing DIP socket. Two 1x4 row pins need to be installed into the PCB's DIP footprint when the device is installed into the appropriate package footprint.

This allows the PCB to convert the SOIC-8, MSOP-8 or TSSOP-8 footprints to a 300-mil DIP-8 footprint.

2.4.7 Evaluating a Voltage Supervisor or Voltage Detector Device

2.4.7.1 VOLTAGE SUPERVISORS

The following voltage supervisor is supported by this evaluation board.

TABLE 2-3: 8-PIN VOLTAGE SUPERVISOR

Device	SOIC	DIP	MSOP	TSSOP	Comment
TC1232	Yes	Yes	—	—	

2.4.7.2 TESTING THE VOLTAGE SUPERVISORS TRIP POINT OPERATION

When evaluating a voltage supervisor/voltage detector device, a minimum set of test equipment should be available. Table 2-4 shows the recommended test equipment.

TABLE 2-4: TEST EQUIPMENT

Hardware	Connect to:	Comment
Variable Power Supply	V_{DD} , V_{SS}	This allows the voltage to the SOT23 Evaluation Board to be varied so the device output can be monitored.
Arbitrary Waveform Generator	V_{DD} , V_{SS}	This is similar to a variable power supply, but allows programmability into the input signal that the device will be subjected to. This also allows a particular waveform to be repeated (such as a 60 Hz sine wave that varies from 1V to 5V).
Digital Multi-Meter (D.M.M.)	$V_{OUT}^{(1)}$	Used to indicate the output state (low or high) of the voltage supervisor/voltage detector.
Oscilloscope	$V_{OUT}^{(1)}$	Allows the device conditions and response to be evaluated due to the ability to capture this information. This is useful for faster signals and cases where small spikes need to be detected.
Test Light (LED)	$V_{OUT}^{(1)}$	Used to visually indicate the output state (low or high) of the voltage supervisor/voltage detector. Ensure that the current requirements of this LED can be supplied by the device's output pin.

Note 1: The pad connection to connect to the V_{OUT} or RST pin will be dependent on the device and the footprint option used.

8-Pin SOIC/MSOP/TSSOP/DIP Evaluation Board User's Guide

A typical system that would be used to evaluate the voltage supervisor/voltage detector device is shown in Figure 2-7. This also shows an example input and output waveform for a voltage supervisor/voltage detector device.

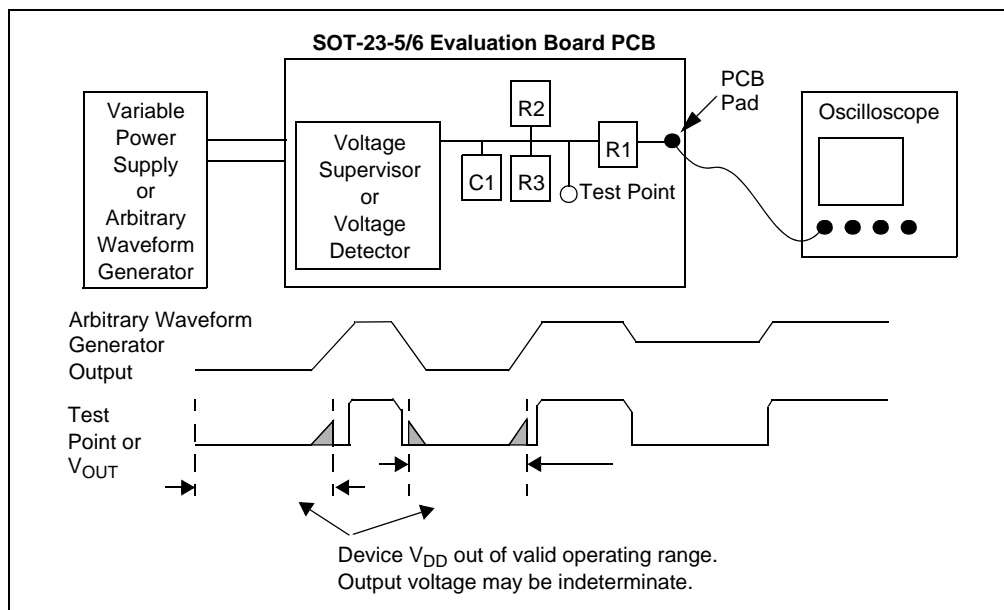

FIGURE 2-7: Evaluation System.

2.4.8 Example Op Amp Circuits

This section shows how the 8-Pin SOIC/MSOP/TSSOP/DIP Evaluation Board could be used to evaluate op amp circuits. The first circuit is for the MCP601 and is shown in Figure 2-8. Figure 2-9 shows which components on the PCB would be installed and how the “unconnected” passive components would be jumpered into the circuit.

The second circuit is for the MCP6021 and is shown in Figure 2-10. Figure 2-11 shows which components on the PCB would be installed and how the “unconnected” passive components would be jumpered into the circuit.

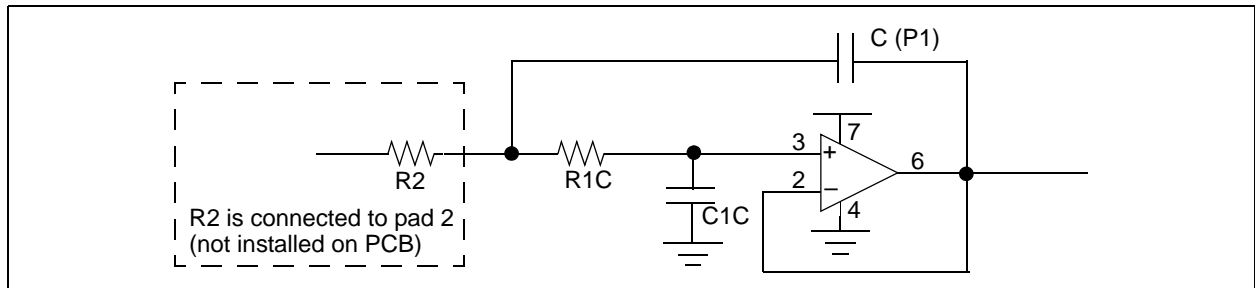

FIGURE 2-8: Op Amp Circuit #1 (MCP601).

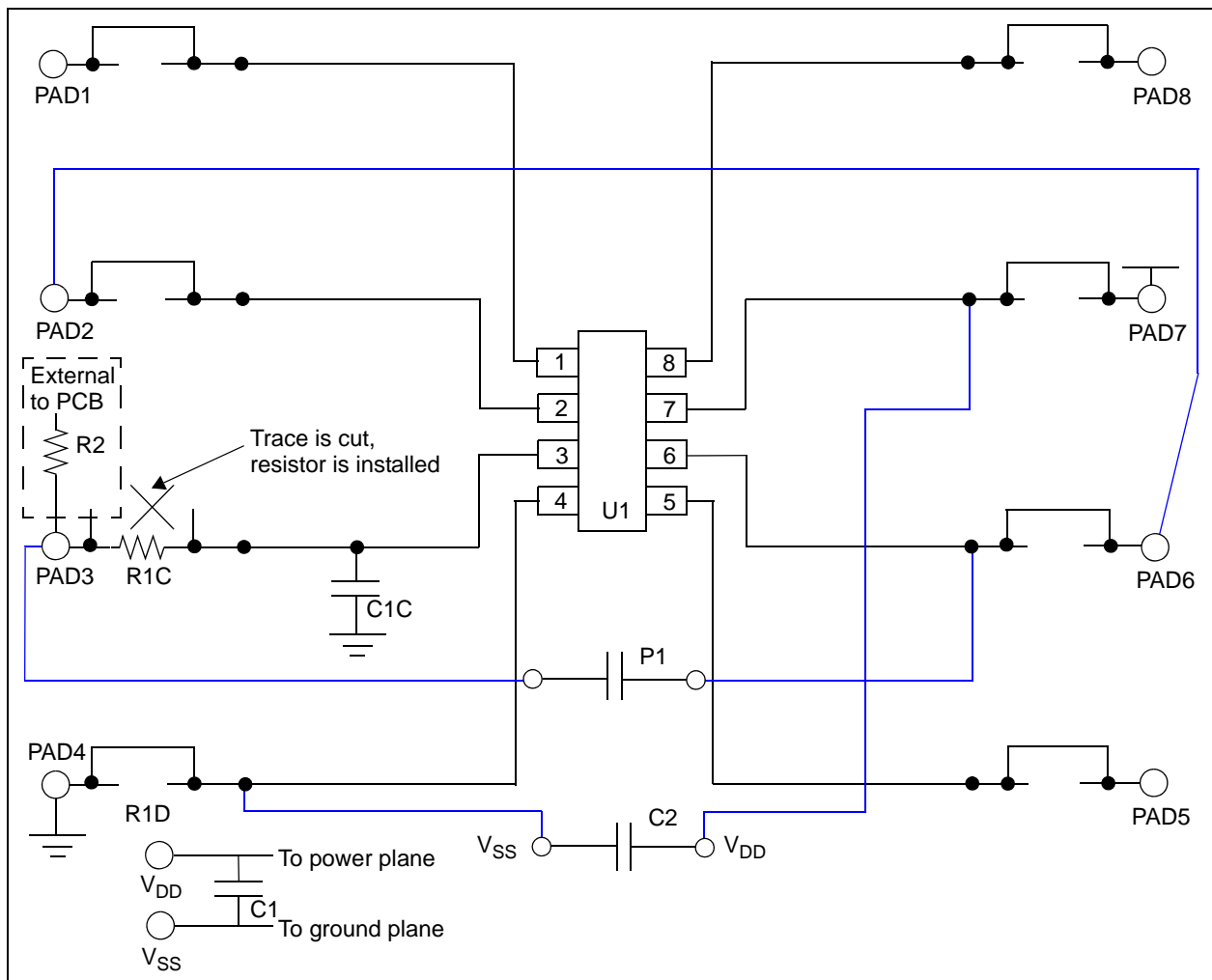

FIGURE 2-9: PCB Connections for Op Amp Circuit #1 (MCP601).

8-Pin SOIC/MSOP/TSSOP/DIP Evaluation Board User's Guide

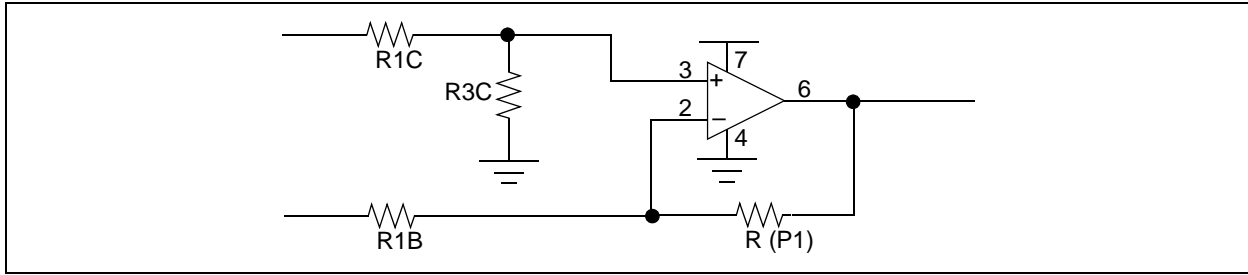

FIGURE 2-10: Op Amp Circuit #2 (MCP6021).

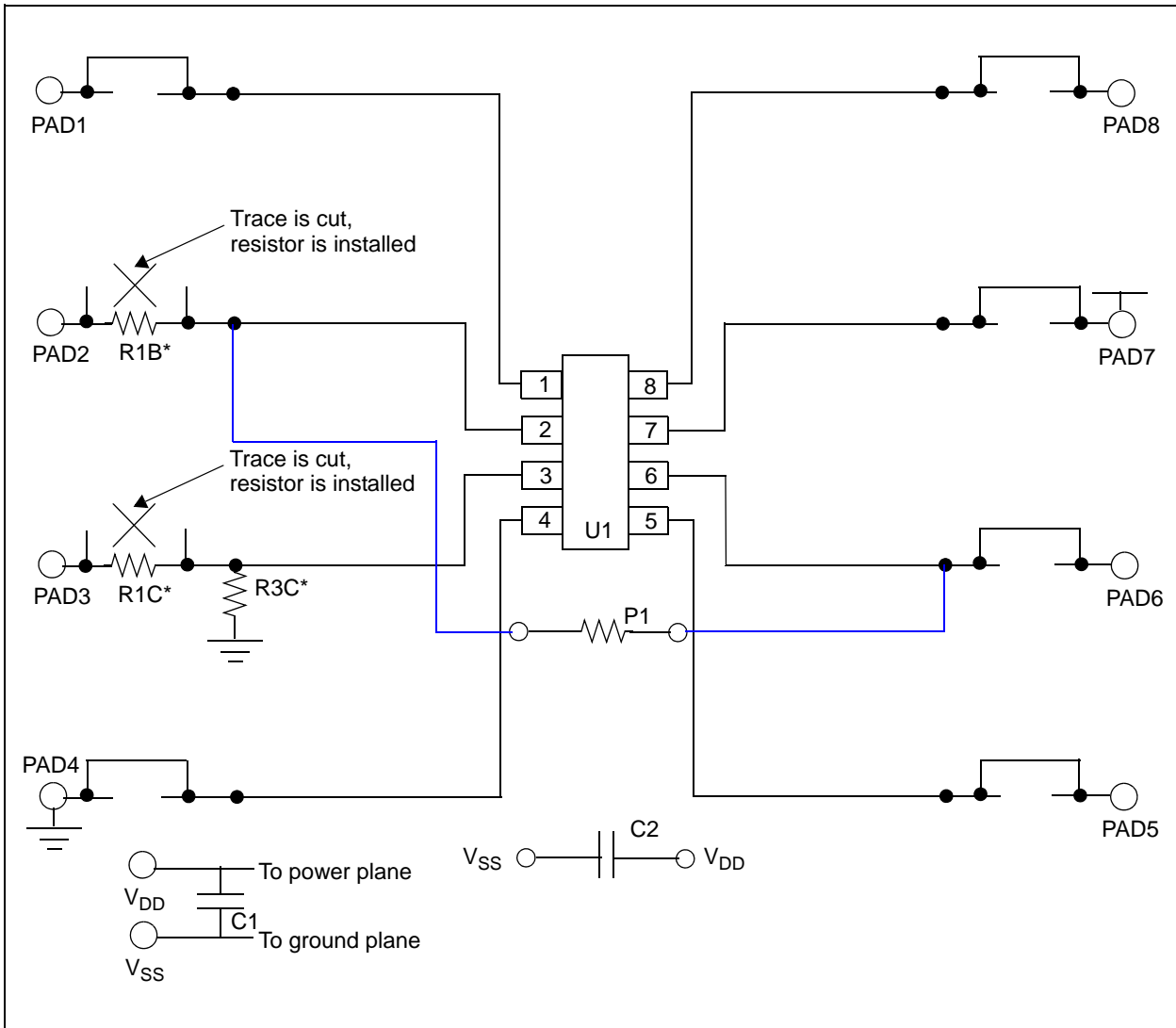

FIGURE 2-11: PCB Op Amp Circuit #2 (MCP6021).



8-PIN SOIC/MSOP/TSSOP/DIP EVALUATION BOARD USER'S GUIDE

Appendix A. Schematic and Layouts

A.1 INTRODUCTION

This appendix contains the schematics and layouts for the 8-Pin SOIC/MSOP/TSSOP/DIP Evaluation Board. Diagrams included in this appendix:

- Board Schematic - Digital Circuitry
- Board – Top Layer + Bottom Layer + Silk-Screen
- Board – Top Layer + Silk-Screen
- Board – Bottom Layer
- Board – Power Plane
- Board – Ground Plane
- Board – Component Layer

A.2 SCHEMATICS AND PCB LAYOUT

Figure A-3 shows the schematic of the 8-Pin SOIC/MSOP/TSSOP/DIP Evaluation Board.

Figure A-2 shows the layout for the top layer of the 8-Pin SOIC/MSOP/TSSOP/DIP Evaluation Board. The layer order is shown in Figure A-1.

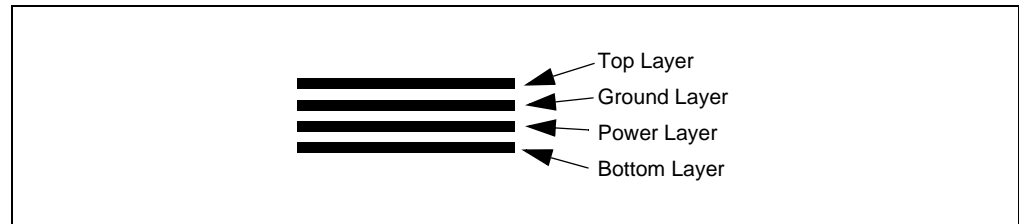

FIGURE A-1: *Layer Order.*

8-Pin SOIC/MSOP/TSSOP/DIP Evaluation Board User's Guide

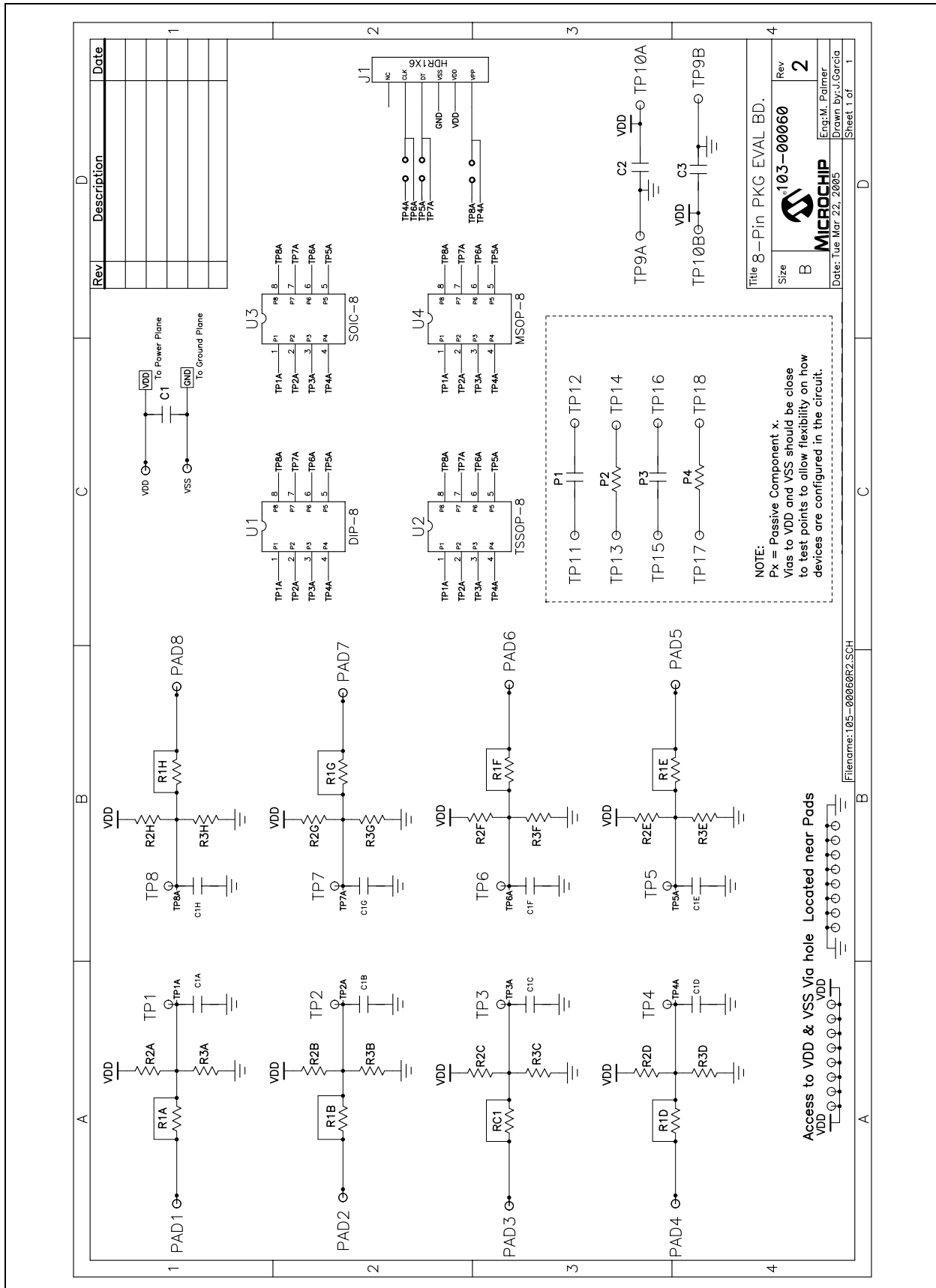

FIGURE A-2: 8-Pin SOIC/MSOP/TSSOP/DIP Evaluation Board Schematic.

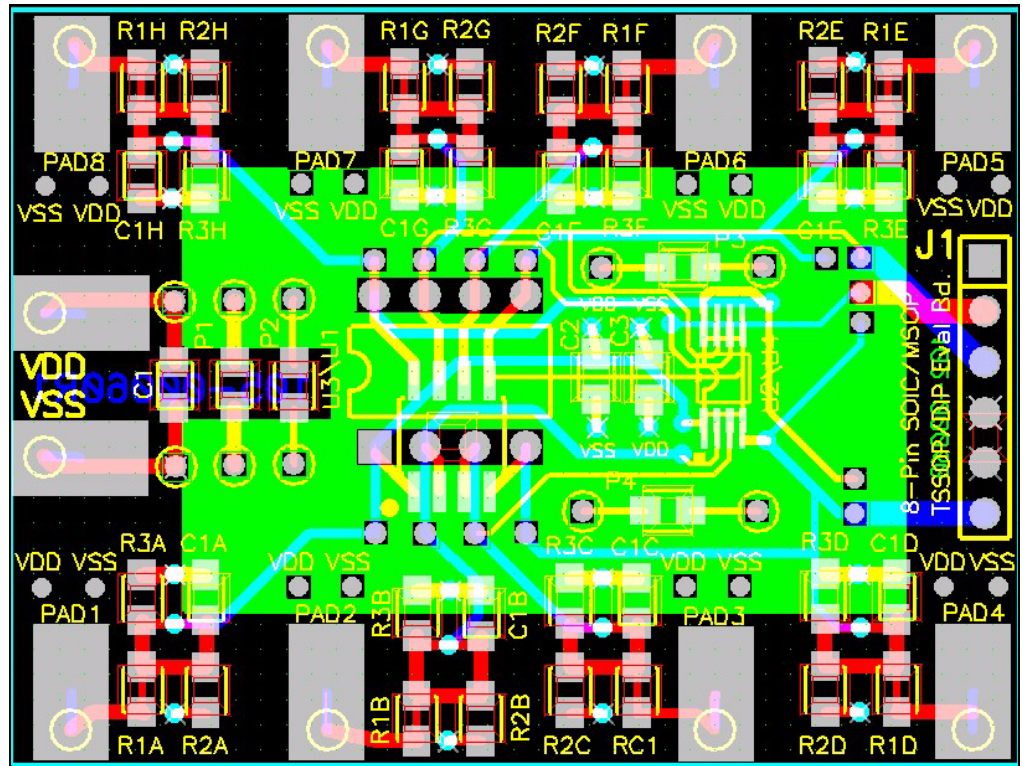

FIGURE A-3: 8-Pin SOIC/MSOP/TSSOP/DIP Evaluation Board Layout – Top Layer + Bottom Layer + Silk-Screen.

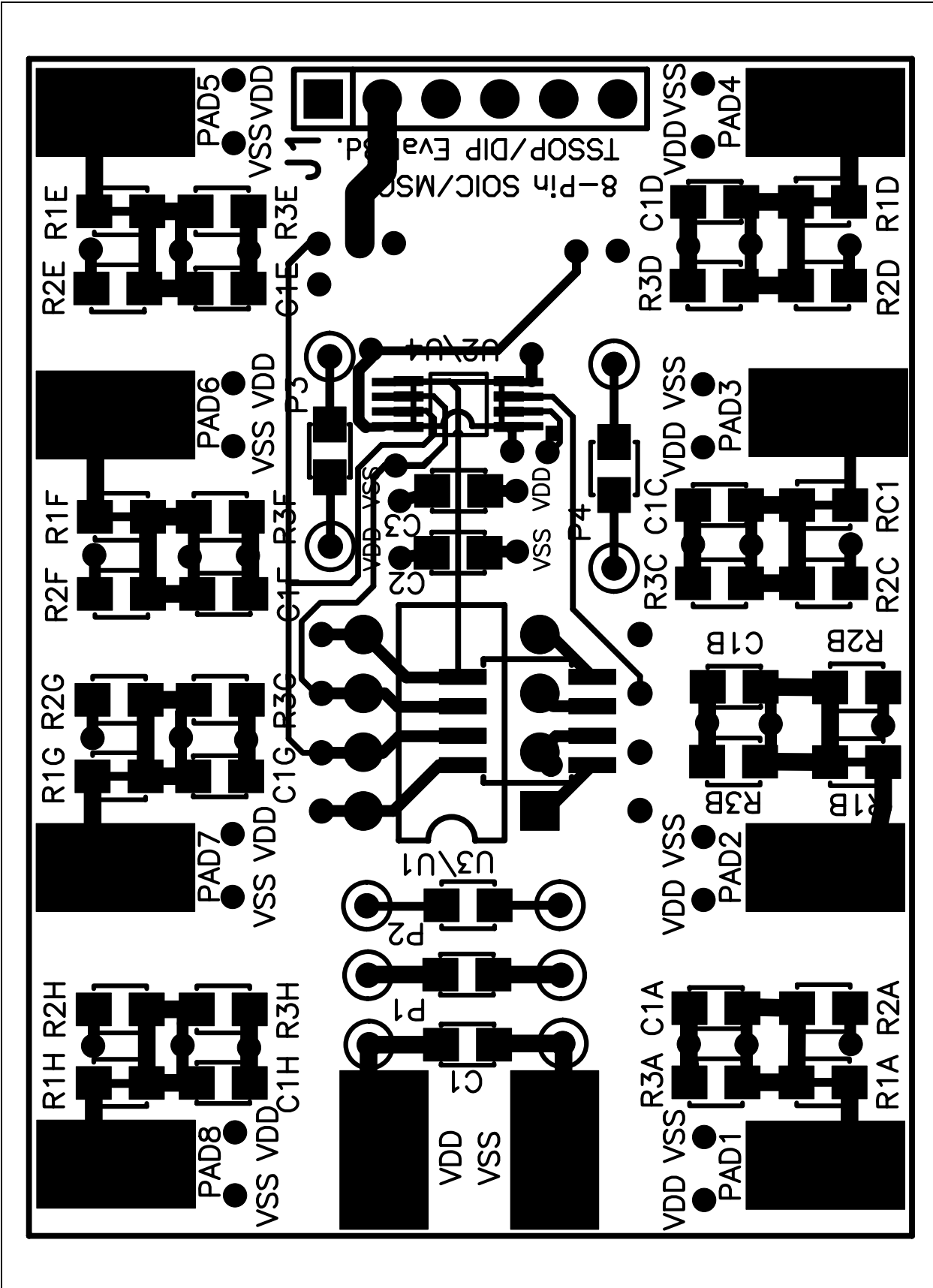

FIGURE A-4: 8-Pin SOIC/MSOP/TSSOP/DIP Evaluation Board Gerber – Top Layer + Silk-Screen.

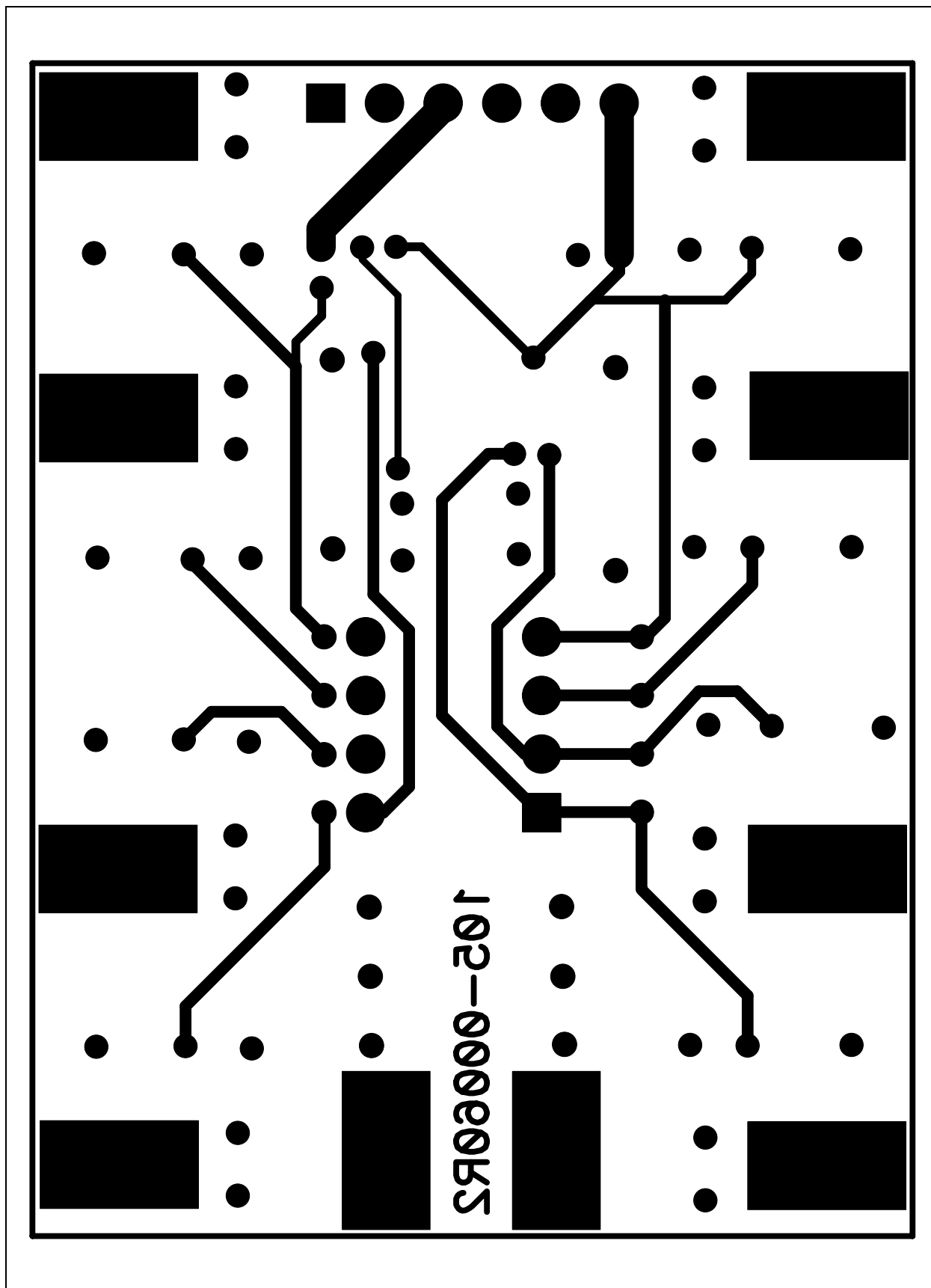

FIGURE A-5: 8-Pin SOIC/MSOP/TSSOP/DIP Evaluation Board Gerber – Bottom Layer.

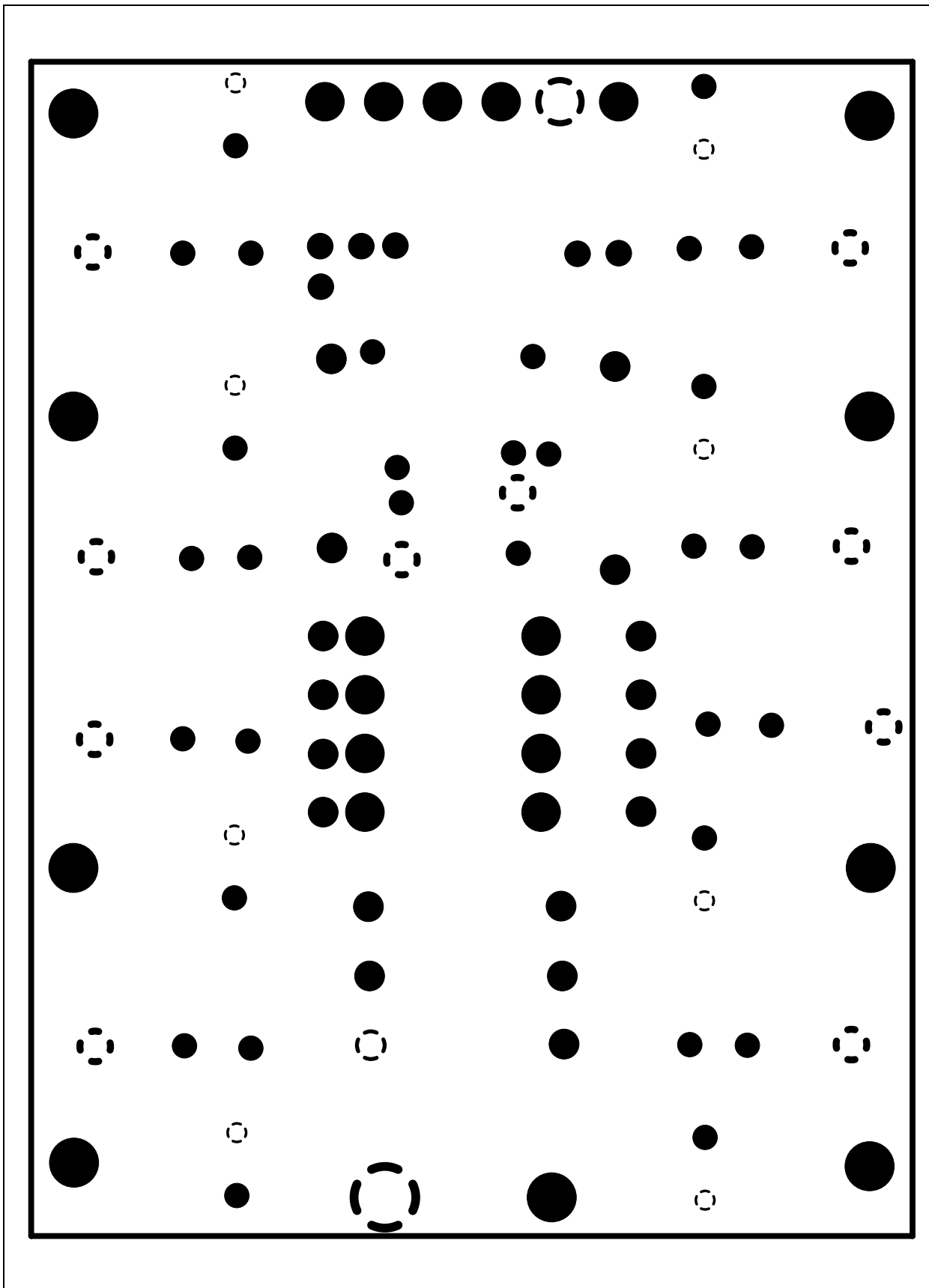

FIGURE A-6: 8-Pin SOIC/MSOP/TSSOP/DIP Evaluation Board Gerber – Power Plane

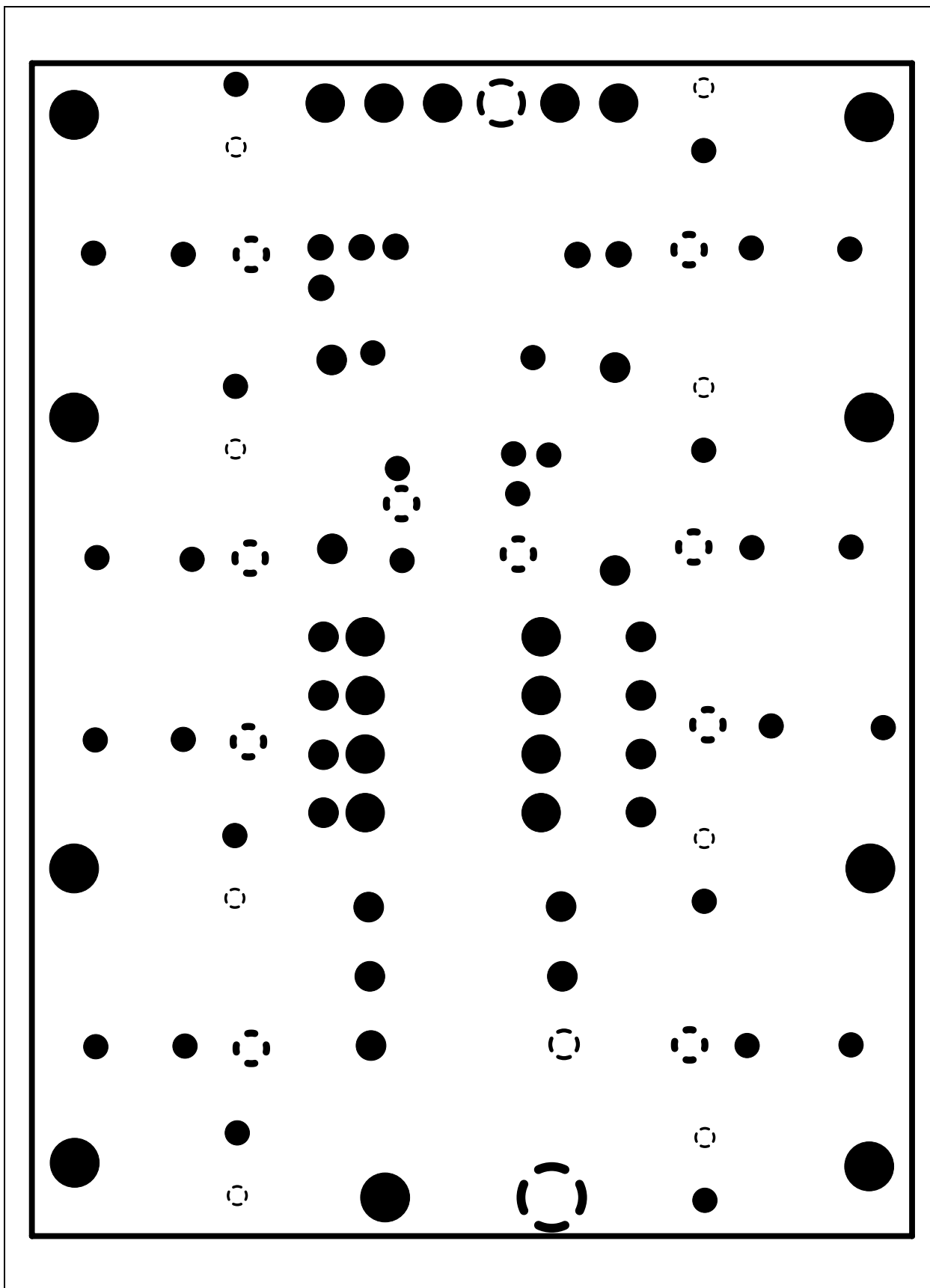

FIGURE A-7: 8-Pin SOIC/MSOP/TSSOP/DIP Evaluation Board Gerber – Ground Plane.

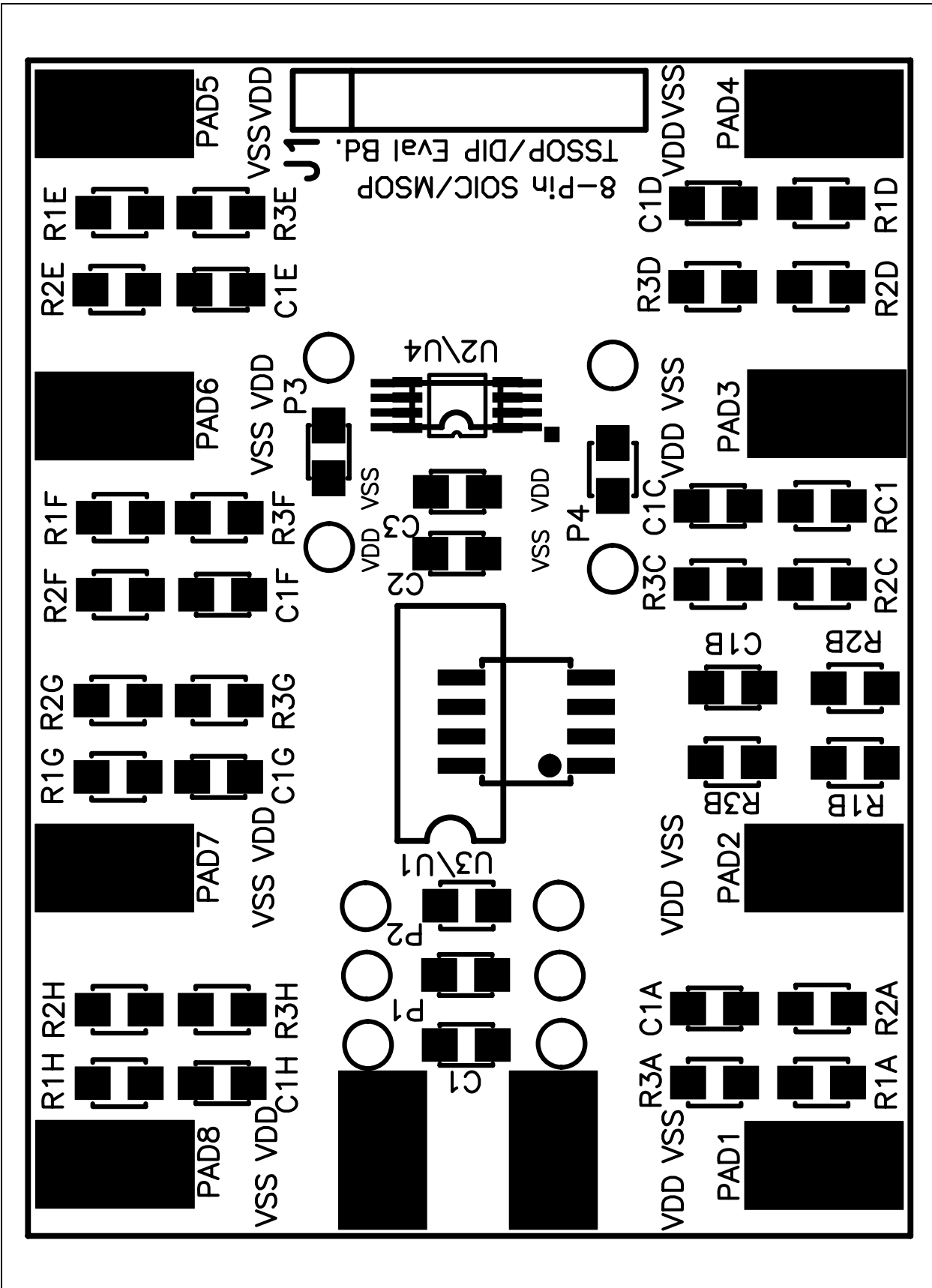

FIGURE A-8: 8-Pin SOIC/MSOP/TSSOP/DIP Evaluation Board Gerber – Component Layer.



8-PIN SOIC/MSOP/TSSOP/DIP EVALUATION BOARD USER'S GUIDE

Appendix B. Bill of Materials (BOM)

TABLE B-1: BILL OF MATERIALS

Qty	Reference	Description	Manufacturer	Part Number
1	PCB 103-00050	SOT23 Evaluation Board PCB	Microchip Technology Inc.	103-00060
0	U1	SOIC-8 Device	Microchip Technology Inc.	User-specified
0	U2	MSOP-8 Device	Microchip Technology Inc.	User-specified
0	U3	DIP-8 Device	Microchip Technology Inc.	User-specified
0	U4	TSSOP-8 Device	Microchip Technology Inc.	User-specified
0	C1, C2, C3	Device Power Supply Bypass Capacitor Surface-mount (805 package) (Optional - Application-dependent)	—	User-specified
0	C1A, C1B, C1C, C1D, C1E, C1F, C1G, C1H	Output Filter Capacitor Surface-mount (805 package) (Optional - Application-dependent)	—	User-specified
0	R1A, R1B, R1C, R1D, R1E, R1F, R1G, R1H	Output inline resistor Surface-mount (805 package) (Optional - Application-dependent)	—	User-specified
0	R2A, R2B, R2C, R2D, R2E, R2F, R2G, R2H	Output Pull-up resistor Surface-mount (805 package) (Optional - Application-dependent)	—	User-specified
0	R3A, R3B, R3C, R3D, R3E, R3F, R3G, R3H	Output Pull-down resistor Surface-mount (805 package) (Optional - Application-dependent)	—	User-specified
0	P1, P2, P3, P4	Passive component (not connected) that can be "blue wired" into the desired circuit. The device layout supports the 805 package. (Optional - Application-dependent)		
0	J1	BFMP Header (6-pin, 100 mil spacing)	—	—
0	PAD1, PAD2, PAD3, PAD4, PAD5, PAD6, PAD7, PAD8, V _{DD} , V _{SS}	Through-hole connector(s) for PAD1, PAD2, PAD3, PAD4, PAD5, PAD6, PAD7, PAD8, V _{DD} , V _{SS}	Keystone Electronics®	5012
0	PAD1, PAD2, PAD3, PAD4, PAD5, PAD6, PAD7, PAD8, V _{DD} , V _{SS}	Surface-mount connector(s) for PAD1, PAD2, PAD3, PAD4, PAD5, PAD6, PAD7, PAD8, V _{DD} , V _{SS}	Keystone Electronics®	5016

8-Pin SOIC/MSOP/TSSOP/DIP Evaluation Board User's Guide

NOTES:



8-PIN SOIC/MSOP/TSSOP/DIP EVALUATION BOARD USER'S GUIDE

Appendix C. Microchip Analog and Interface Device Compatibility

C.1 INTRODUCTION

This appendix documents the Microchip Analog and Interface devices that are footprint compatible with this PCB.

The Analog and Interface devices currently fall into the following categories:

- A/D Converters (ADCs) (ADCs)
- Battery Chargers
- Comparators
- D/A Converters (DACs) (DACs)
- DC-to-DC Converters
- Digital Potentiometers (Digi-Pots)
- Fan Controllers
- Integrated Devices
- Interface Devices
- Linear Regulators
- Operational Amplifiers (Op Amps)
- Power MOSFET Drivers
- Programmable Gain Amplifiers (PGAs)s (PGAs)
- Switching Regulators
- Temperature Sensors
- Voltage Supervisors and Voltage Detectors

Table C-1 shows the Microchip Analog and Interface devices that are currently supported. As new devices become available, this PCB may be able to support them. Please check the device data sheet to verify if the device is available in one of the package types supported by this PCB.

8-Pin SOIC/MSOP/TSSOP/DIP Evaluation Board User's Guide

TABLE C-1: ANALOG AND INTERFACE DEVICES PCB COMPATIBILITY

Device	SOIC	DIP	MSOP	TSSOP	Comment
Voltage Supervisors and Voltage Detectors					
TC1232	Yes	Yes	—	—	
Digital Potentiometer					
MCP4021	Yes	—	Yes	—	
MCP41010	Yes	Yes	—	—	
MCP41050	Yes	Yes	—	—	
MCP41100	Yes	Yes	—	—	
Switching Regulator					
MCP1601	—	—	Yes	—	
MCP1612	—	—	Yes	—	
MCP1630	—	—	Yes	—	
MCP1650	—	—	Yes	—	
MCP1651	—	—	Yes	—	
MCP1652	—	—	Yes	—	
DC-to-DC Converters					
MCP1252	—	—	Yes	—	
MCP1253	—	—	Yes	—	
TC682	Yes	Yes	—	—	
TC962	Yes	Yes	—	—	
TC1044S	Yes	Yes	—	—	
TC1121	Yes	Yes	Yes	—	
TC1142	—	—	Yes	—	
TC7660	Yes	Yes	—	—	
TC7660B	Yes	Yes	—	—	
TC7660H	Yes	Yes	—	—	
TC7660S	Yes	Yes	—	—	
TCM680	Yes	Yes	—	—	
Linear Regulators					
MCP1726	Yes	—	—	—	
TC1107	Yes	—	Yes	—	
TC1173	Yes	—	Yes	—	
TC1174	Yes	—	Yes	—	
TC1263	Yes	—	—	—	
TC1265	Yes	—	—	—	
TC1266	Yes	—	Yes	—	
TC1268	Yes	—	—	—	
TC1269	—	—	Yes	—	
TC1300	—	—	Yes	—	
TC1301A	—	—	Yes	—	
TC1301B	—	—	Yes	—	
TC1302A	—	—	Yes	—	
TC1302B	—	—	Yes	—	
TC1306	—	—	Yes	—	

Note 1: Installation of PCB capacitor C2 (or C3) is recommended for all devices. See data sheet for recommended value.

2: Installation of PCB capacitor C1 recommended. See data sheet for recommended value.

Microchip Analog and Interface Device Compatibility

TABLE C-1: ANALOG AND INTERFACE DEVICES PCB COMPATIBILITY

Device	SOIC	DIP	MSOP	TSSOP	Comment
Operational Amplifiers (Op Amps)					
MCP601	Yes	Yes	—	Yes	Note 2
MCP602	Yes	Yes	—	Yes	Note 2
MCP603	Yes	Yes	—	Yes	Note 2
MCP606	Yes	Yes	—	Yes	
MCP607	Yes	Yes	—	Yes	
MCP608	Yes	Yes	—	Yes	
MCP616	Yes	Yes	Yes	—	
MCP617	Yes	Yes	Yes	—	
MCP618	Yes	Yes	Yes	—	
MCP6001	Yes	Yes	Yes	—	
MCP6004	Yes	Yes	Yes	—	
MCP6021	Yes	Yes	—	Yes	Note 2
MCP6022	Yes	Yes	—	Yes	Note 2
MCP6023	Yes	Yes	—	Yes	Note 2
MCP6041	Yes	Yes	Yes	—	
MCP6042	Yes	Yes	Yes	—	
MCP6043	Yes	Yes	Yes	—	
MCP6141	Yes	Yes	Yes	—	
MCP6142	Yes	Yes	Yes	—	
MCP6143	Yes	Yes	Yes	—	
MCP6231	Yes	Yes	Yes	—	
MCP6232	Yes	Yes	Yes	—	
MCP6241	Yes	Yes	Yes	—	
MCP6242	Yes	Yes	Yes	—	
MCP6271	Yes	Yes	Yes	—	Note 2
MCP6272	Yes	Yes	Yes	—	Note 2
MCP6273	Yes	Yes	Yes	—	Note 2
MCP6275	Yes	Yes	Yes	—	Note 2
MCP6281	Yes	Yes	Yes	—	Note 2
MCP6282	Yes	Yes	Yes	—	Note 2
MCP6283	Yes	Yes	Yes	—	Note 2
MCP6285	Yes	Yes	Yes	—	Note 2
MCP6291	Yes	Yes	Yes	—	Note 2
MCP6292	Yes	Yes	Yes	—	Note 2
MCP6293	Yes	Yes	Yes	—	Note 2
MCP6295	Yes	Yes	Yes	—	Note 2
TC913	—	Yes	—	—	
TC1029	Yes	Yes	Yes	—	
TC7650	—	Yes	—	—	
TC7652	—	Yes	—	—	

Note 1: Installation of PCB capacitor C2 (or C3) is recommended for all devices. See data sheet for recommended value.

2: Installation of PCB capacitor C1 recommended. See data sheet for recommended value.

8-Pin SOIC/MSOP/TSSOP/DIP Evaluation Board User's Guide

TABLE C-1: ANALOG AND INTERFACE DEVICES PCB COMPATIBILITY

Device	SOIC	DIP	MSOP	TSSOP	Comment
Programmable Gain Amplifiers (PGAs)					
MCP6S21	Yes	Yes	Yes	—	Note 2
MCP6S22	Yes	Yes	Yes	—	Note 2
MCP6S91	Yes	Yes	Yes	—	Note 2
MCP6S92	Yes	Yes	Yes	—	Note 2
Power MOSFET Drivers					
TC1410	Yes	Yes	Yes	—	
TC1410N	Yes	Yes	Yes	—	
TC1411	Yes	Yes	Yes	—	
TC1411N	Yes	Yes	Yes	—	
TC1426	Yes	Yes	—	—	
TC1427	Yes	Yes	—	—	
TC1428	Yes	Yes	—	—	
TC4403	—	Yes	—	—	
TC4426A	Yes	Yes	—	—	
TC4427A	Yes	Yes	—	—	
TC4428A	Yes	Yes	—	—	
TC4426	Yes	Yes	Yes	—	
TC4427	Yes	Yes	Yes	—	
TC4428	Yes	Yes	Yes	—	
TC426	Yes	Yes	—	—	
TC427	Yes	Yes	—	—	
TC428	Yes	Yes	—	—	
TC4404	Yes	Yes	—	—	
TC4405	Yes	Yes	—	—	
TC1412	Yes	Yes	Yes	—	
TC1412N	Yes	Yes	Yes	—	
TC1413	Yes	Yes	Yes	—	
TC1413N	Yes	Yes	Yes	—	
TC4423	—	Yes	—	—	
TC4424	—	Yes	—	—	
TC4425	—	Yes	—	—	
TC429	Yes	Yes	—	—	
TC4420	Yes	Yes	—	—	
TC4429	Yes	Yes	—	—	
TC4421	—	Yes	—	—	
TC4422	—	Yes	—	—	
TC4626	—	Yes	—	—	
TC4627	—	Yes	—	—	
TC4431	Yes	Yes	—	—	
TC4432	Yes	Yes	—	—	

- Note 1:** Installation of PCB capacitor C2 (or C3) is recommended for all devices. See data sheet for recommended value.
- 2:** Installation of PCB capacitor C1 recommended. See data sheet for recommended value.

Microchip Analog and Interface Device Compatibility

TABLE C-1: ANALOG AND INTERFACE DEVICES PCB COMPATIBILITY

Device	SOIC	DIP	MSOP	TSSOP	Comment
Comparators					
MCP6541	Yes	Yes	Yes	—	
MCP6542	Yes	Yes	Yes	—	
MCP6543	Yes	Yes	Yes	—	
MCP6546	Yes	Yes	Yes	—	
MCP6547	Yes	Yes	Yes	—	
MCP6548	Yes	Yes	Yes	—	
TC1025	Yes	Yes	Yes	—	
TC1028	—	—	Yes	—	
TC1031	—	—	Yes	—	
TC1040	—	—	Yes	—	
TC1041	Yes	—	Yes	—	
A/D Converters (ADCs)					
MCP3001	Yes	Yes	—	Yes	
MCP3002	Yes	Yes	—	Yes	
MCP3201	Yes	Yes	—	Yes	
MCP3202	Yes	Yes	—	Yes	
MCP3301	Yes	Yes	Yes	—	
TC3400	Yes	Yes	—	—	
D/A Converters (DACs)					
MCP4821	Yes	Yes	Yes	—	
MCP4822	Yes	Yes	Yes	—	
MCP4921	Yes	Yes	Yes	—	
TC1320	Yes	—	Yes	—	
TC1321	Yes	—	Yes	—	

- Note 1:** Installation of PCB capacitor C2 (or C3) is recommended for all devices. See data sheet for recommended value.
- 2:** Installation of PCB capacitor C1 recommended. See data sheet for recommended value.

8-Pin SOIC/MSOP/TSSOP/DIP Evaluation Board User's Guide

TABLE C-1: ANALOG AND INTERFACE DEVICES PCB COMPATIBILITY

Device	SOIC	DIP	MSOP	TSSOP	Comment
Temperature Sensors					
MCP9801	Yes	—	Yes	—	
MCP9803	Yes	—	Yes	—	
TC72	—	—	Yes	—	
TCN75	Yes	—	Yes	—	
TC620	Yes	Yes	—	—	
TC621	Yes	Yes	—	—	
TC622	Yes	Yes	—	—	
TC623	Yes	Yes	—	—	
TC624	Yes	Yes	—	—	
Fan Controllers					
TC642	Yes	Yes	Yes	—	
TC642B	Yes	Yes	Yes	—	
TC646	Yes	Yes	Yes	—	
TC646B	Yes	Yes	Yes	—	
TC647	Yes	Yes	Yes	—	
TC647B	Yes	Yes	Yes	—	
TC648	Yes	Yes	Yes	—	
TC648B	Yes	Yes	Yes	—	
TC649	Yes	Yes	Yes	—	
TC649B	Yes	Yes	Yes	—	
TC650	—	—	Yes	—	
TC651	—	—	Yes	—	
TC652	—	—	Yes	—	
TC653	—	—	Yes	—	
Battery Chargers					
MCP7344	—	—	Yes	—	
MCP73827	—	—	Yes	—	
MCP73828	—	—	Yes	—	
MCP73843	—	—	Yes	—	
Integrated Devices					
TC1026C	Yes	Yes	Yes	—	
Interface Devices					
MCP201	Yes	Yes	—	—	
MCP2122	Yes	Yes	—	—	
MCP2551	Yes	Yes	—	—	

- Note 1:** Installation of PCB capacitor C2 (or C3) is recommended for all devices. See data sheet for recommended value.
- Note 2:** Installation of PCB capacitor C1 recommended. See data sheet for recommended value.



MICROCHIP 8-PIN SOIC/MSOP/TSSOP/DIP EVALUATION BOARD USER'S GUIDE

Appendix D. Rev. 1 PCB Errata

D.1 INTRODUCTION

This appendix documents the issues with the Rev 1 PCB. The Rev 2 PCB fixes these issues.

D.2 REV 1 PCB ISSUES

There are two issues with the Rev 1 PCB. These are:

1. VDD and VSS vias near each pad are No Connects (they should have been connected to the appropriate power or ground plane). See Figure D-1 shows the location of these vias that are No Connects. Figure D-3 shows alternate connections that can be made.
2. The silk-screen on the bottom layer was not processed. This was only intended for indicating the circuit of the board. This can be done with a sticky label.

Figure D-2 shows how to determine the PCB revision.

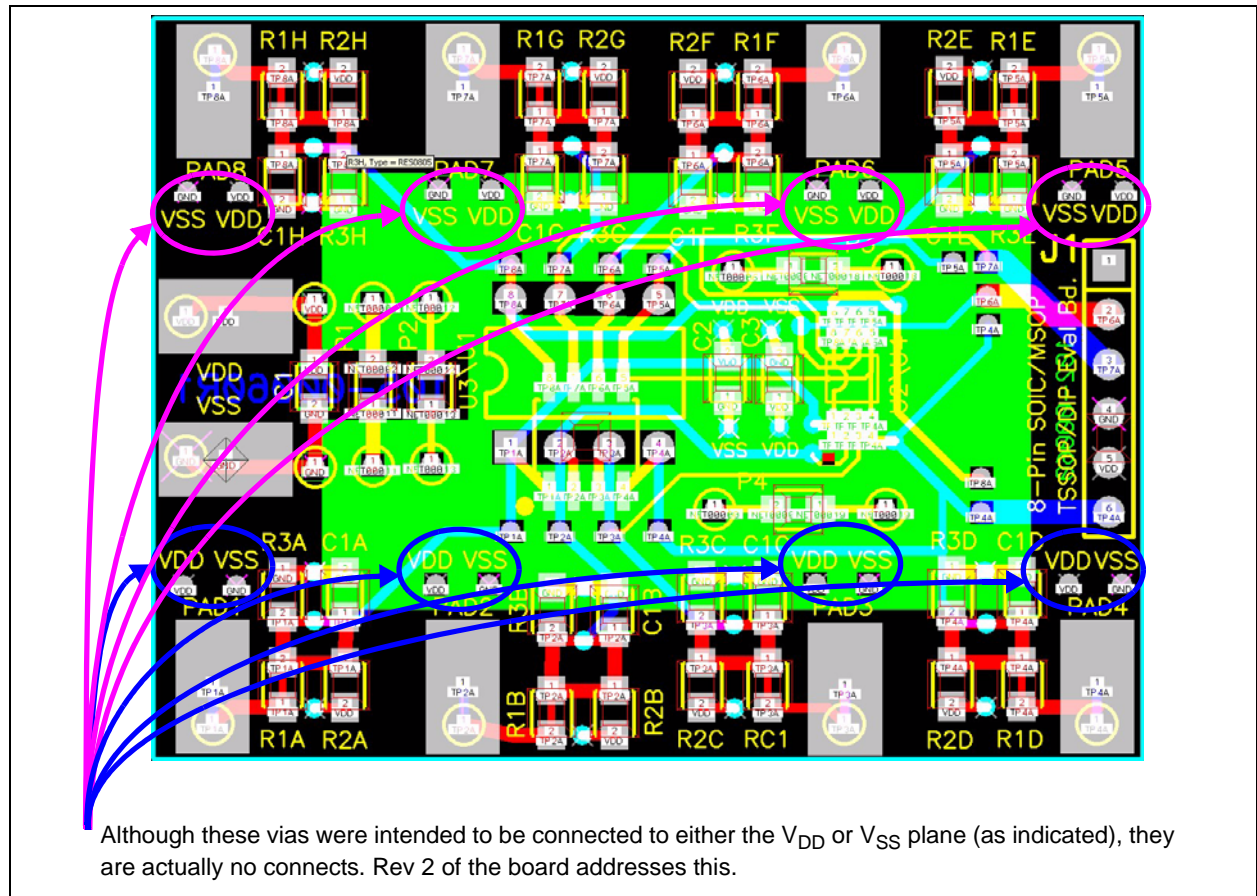

FIGURE D-1: 8-Pin SOIC/MSOP/TSSOP/DIP Evaluation Board Gerber - Top Layer + Silk-Screen.

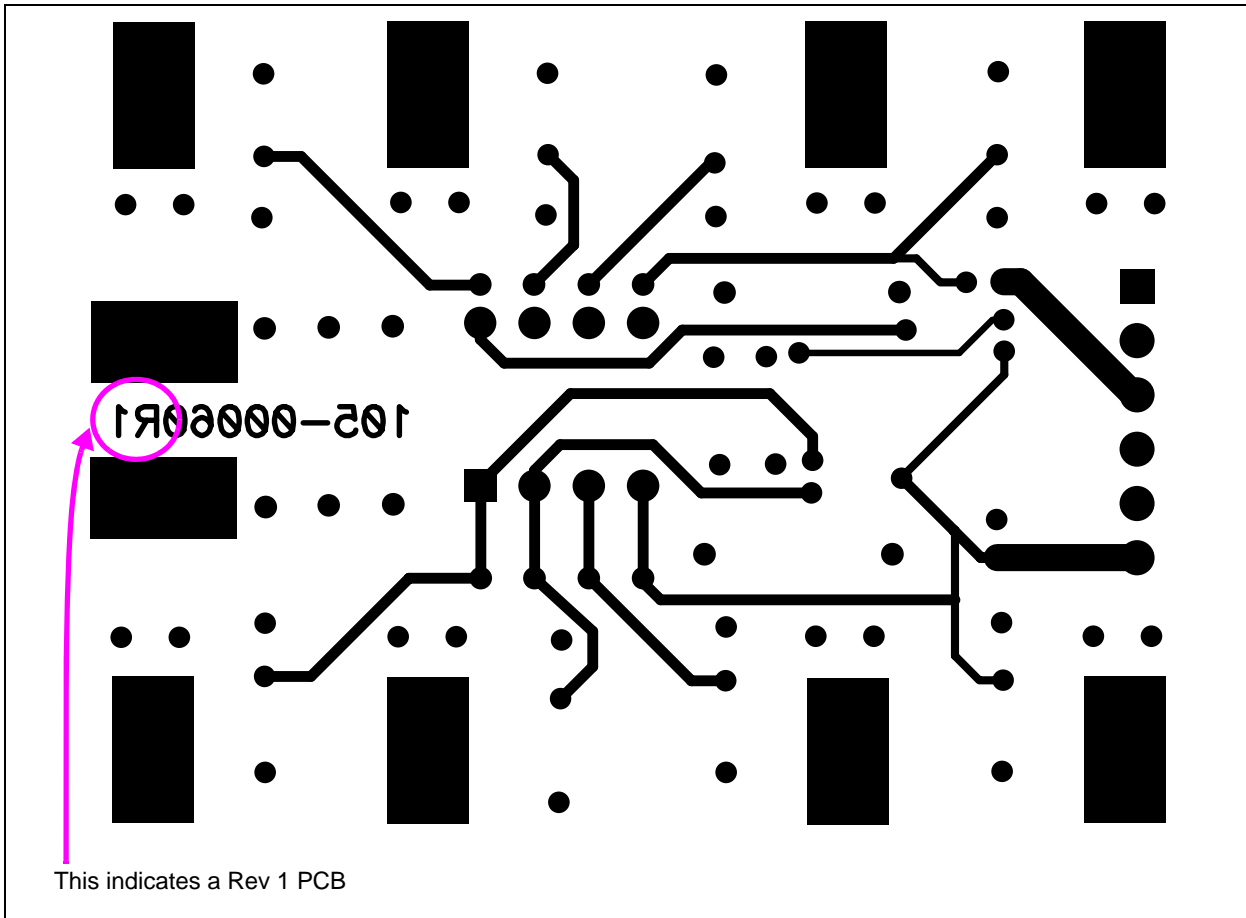

FIGURE D-2: 8-Pin SOIC/MSOP/TSSOP/DIP Evaluation Board Revision Marking
(Gerber – Bottom Layer)

Figure D-3 shows how the pad can be connected to either the V_{DD} or V_{SS} plane of the PCB.

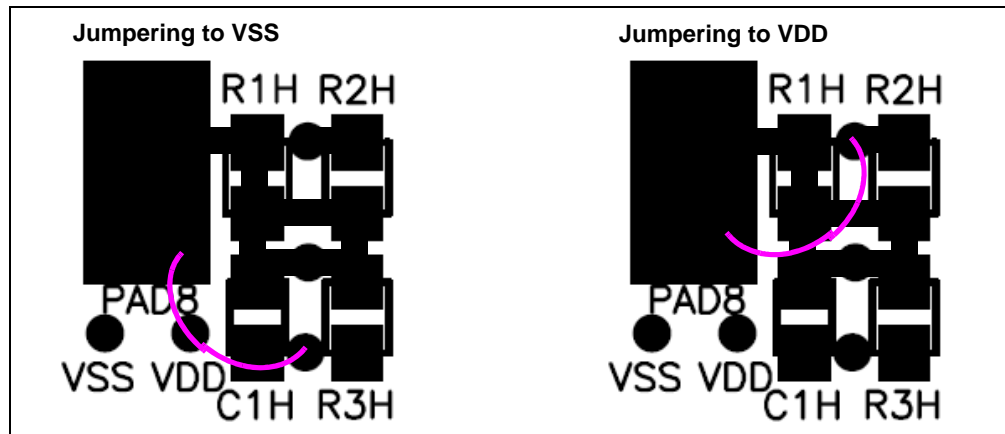

FIGURE D-3: *Alternate Jumpering the PCB pad to either VSS or VDD.*



WORLDWIDE SALES AND SERVICE

AMERICAS

Corporate Office
2355 West Chandler Blvd.
Chandler, AZ 85224-6199
Tel: 480-792-7200
Fax: 480-792-7277
Technical Support:
<http://support.microchip.com>
Web Address:
www.microchip.com

Atlanta
Alpharetta, GA
Tel: 770-640-0034
Fax: 770-640-0307

Boston
Westborough, MA
Tel: 774-760-0087
Fax: 774-760-0088

Chicago
Itasca, IL
Tel: 630-285-0071
Fax: 630-285-0075

Dallas
Addison, TX
Tel: 972-818-7423
Fax: 972-818-2924

Detroit
Farmington Hills, MI
Tel: 248-538-2250
Fax: 248-538-2260

Kokomo
Kokomo, IN
Tel: 765-864-8360
Fax: 765-864-8387

Los Angeles
Mission Viejo, CA
Tel: 949-462-9523
Fax: 949-462-9608

San Jose
Mountain View, CA
Tel: 650-215-1444
Fax: 650-961-0286

Toronto
Mississauga, Ontario,
Canada
Tel: 905-673-0699
Fax: 905-673-6509

ASIA/PACIFIC

Australia - Sydney
Tel: 61-2-9868-6733
Fax: 61-2-9868-6755

China - Beijing
Tel: 86-10-8528-2100
Fax: 86-10-8528-2104

China - Chengdu
Tel: 86-28-8676-6200
Fax: 86-28-8676-6599

China - Fuzhou
Tel: 86-591-8750-3506
Fax: 86-591-8750-3521

China - Hong Kong SAR
Tel: 852-2401-1200
Fax: 852-2401-3431

China - Shanghai
Tel: 86-21-5407-5533
Fax: 86-21-5407-5066

China - Shenyang
Tel: 86-24-2334-2829
Fax: 86-24-2334-2393

China - Shenzhen
Tel: 86-755-8203-2660
Fax: 86-755-8203-1760

China - Shunde
Tel: 86-757-2839-5507
Fax: 86-757-2839-5571

China - Qingdao
Tel: 86-532-502-7355
Fax: 86-532-502-7205

ASIA/PACIFIC

India - Bangalore
Tel: 91-80-2229-0061
Fax: 91-80-2229-0062

India - New Delhi
Tel: 91-11-5160-8631
Fax: 91-11-5160-8632

Japan - Kanagawa
Tel: 81-45-471- 6166
Fax: 81-45-471-6122

Korea - Seoul
Tel: 82-2-554-7200
Fax: 82-2-558-5932 or
82-2-558-5934

Singapore
Tel: 65-6334-8870
Fax: 65-6334-8850

Taiwan - Kaohsiung
Tel: 886-7-536-4818
Fax: 886-7-536-4803

Taiwan - Taipei
Tel: 886-2-2500-6610
Fax: 886-2-2508-0102

Taiwan - Hsinchu
Tel: 886-3-572-9526
Fax: 886-3-572-6459

EUROPE

Austria - Weis
Tel: 43-7242-2244-399
Fax: 43-7242-2244-393

Denmark - Ballerup
Tel: 45-4450-2828
Fax: 45-4485-2829

France - Massy
Tel: 33-1-69-53-63-20
Fax: 33-1-69-30-90-79

Germany - Ismaning
Tel: 49-89-627-144-0
Fax: 49-89-627-144-44

Italy - Milan
Tel: 39-0331-742611
Fax: 39-0331-466781

Netherlands - Drunen
Tel: 31-416-690399
Fax: 31-416-690340

England - Berkshire
Tel: 44-118-921-5869
Fax: 44-118-921-5820



**Стандарт
Электрон
Связь**

Мы молодая и активно развивающаяся компания в области поставок электронных компонентов. Мы поставляем электронные компоненты отечественного и импортного производства напрямую от производителей и с крупнейших складов мира.

Благодаря сотрудничеству с мировыми поставщиками мы осуществляем комплексные и плановые поставки широчайшего спектра электронных компонентов.

Собственная эффективная логистика и склад в обеспечивает надежную поставку продукции в точно указанные сроки по всей России.

Мы осуществляем техническую поддержку нашим клиентам и предпродажную проверку качества продукции. На все поставляемые продукты мы предоставляем гарантию .

Осуществляем поставки продукции под контролем ВП МО РФ на предприятия военно-промышленного комплекса России , а также работаем в рамках 275 ФЗ с открытием отдельных счетов в уполномоченном банке. Система менеджмента качества компании соответствует требованиям ГОСТ ISO 9001.

Минимальные сроки поставки, гибкие цены, неограниченный ассортимент и индивидуальный подход к клиентам являются основой для выстраивания долгосрочного и эффективного сотрудничества с предприятиями радиоэлектронной промышленности, предприятиями ВПК и научно-исследовательскими институтами России.

С нами вы становитесь еще успешнее!

Наши контакты:

Телефон: +7 812 627 14 35

Электронная почта: sales@st-electron.ru

Адрес: 198099, Санкт-Петербург,
Промышленная ул, дом № 19, литера Н,
помещение 100-Н Офис 331