

i.MX 8QuadXPlus MEK Board Hardware User's Guide

1. Introduction

This document is the Hardware User's Guide for the i.MX 8QuadXPlus Multisensory Enablement Kit (MEK) based on the NXP Semiconductor's i.MX 8QuadXPlus Applications Processor. This board is fully supported by NXP Semiconductor. The user guide includes system setup and debugging, and provides detailed information on the overall design and usage of the MEK board from a hardware system perspective.

1.1. Board Overview

The MEK board is a platform designed to showcase the most commonly used features of the i.MX 8QuadXPlus Applications Processor in a small, low cost package. The i.MX 8QuadXPlus MEK board is a development board, which gives the user the option of becoming familiar with the processor before starting development.

Table 1 lists the features of the i.MX 8QuadXPlus MEK board.

Contents

- 1. Introduction 1
 - 1.1. Board Overview 1
 - 1.2. MEK Kit contents 2
 - 1.3. Board revision history 3
- 2. Specifications 4
 - 2.1. Processor 5
 - 2.2. Boot mode operations and selections 6
 - 2.3. Power tree 6
 - 2.4. LPDDR4 DRAM memory 9
 - 2.5. SD card slot (J12) 9
 - 2.6. eMMC memory (U23) 9
 - 2.7. Ethernet connector (J7) 9
 - 2.8. USB Type-C connector (J10) 9
 - 2.9. Audio input/output (J8) 10
 - 2.10. UART connector (J11) 10
 - 2.11. JTAG connector (J4) 10
 - 2.12. M.2 Connector (J5) 11
 - 2.13. MIPI- CSI and MIPI-DSI/LVDS connectors (J1,J2,J3) 11
 - 2.14. Board to Board connector (J13) 12
 - 2.15. User interface buttons 12
 - 2.16. User Interface LEDs 13
 - 2.17. Sensors 13
 - 2.17.1 Accelerometer + Magnetometer (U14) 13
 - 2.17.2 Pressure Sensor with Altimetry (U18) 13
 - 2.17.3 Ambient Light Sensor (U17) 14
 - 2.17.4 Gyroscope (U10) 14
 - 2.18. PCB information 15
 - 2.19. MEK design files 15
- 3. MEK Accessories 15
- 4. Revision History 17



Table 1. Board features

Processor	NXP Applications Processor	PIMX8QX6AVLFZAB *
DRAM memory	Micron 3 GB LPDDR4	MT53B768M32D4DT-062 AIT:B
Mass storage	Micron 32 GB eMMC5.0	MTFC32GAKAEFF-AIT
	Micron 512 Mb QSPI NOR	MT35XU512ABA1G12-0AATES
	SD card connector	
Power	NXP PMIC PF8100 + Discrete DCDC/LDO	
Display interface	LVDS / DSI interface interface (Mini-SAS connector)	
Ethernet	1 Gbps Ethernet with RJ45 connector	
USB	x1 USB (2.0/3.0) Type-C connector	
Audio connectors	3.5 mm Audio jack for Headphone + MIC	
Debug connectors	JTAG (10-PIN header)	
	Micro USB for UART debug	
Camera	CSI interface (Mini-SAS connector)	
Wi-Fi/Bluetooth	x1 M.2 slot (KEY-E type)	
Buttons	ON/OFF, RESET	
LED Indicators	Power, Reset, PMIC ON and PMIC standby status	
Sensors	Accelerometer	FXOS8700CQ
	Gyroscope	FXAS21002CQ
	Pressure Sensor with Altimetry	MPL3115A2
	Ambient light sensor	ISL29023IROZ-T7
PCB	5.24 inch x 5.24 inch (133 mm x 133 mm), 8-layer board	

NOTE

The Processor part number may change to latest with respect to future availability.

1.2. MEK Kit contents

The i.MX 8QuadXPlus MEK contains the following items:

- i.MX 8QuadXPlus CPU Board (MCIMX8QXP – CPU)
- LVDS to HDMI adapter card
- JTAG-GEN2 adapter card
- Power supply (12 V DC, 11.5 A, Level VI, With DIN 4 Pin Output Type)
- AC power cord (IEC cable assembly with locking system for IEC C14 inlet, US version, 1.83 M)
- Worldwide adapter
- Mini SAS cable (IPASS(Mini-SAS), internal cable, 36 CKT 4X W/ Sidebands)

- Ribbon cable (Ribbon IDC, 1.27 MM, 4", 10POS)
- USB type -C cable (USB 3.0 Type-A Female, USB Type-C Male, Shielded, 200 mm)
- SD card with BSP image
- Micro USB cable (USB Type-A Male, USB Micro-B Male,1M)
- Quick Start Guide

1.3. Board revision history

- Rev A2
- Rev B1/B2
- Rev C1/C2

The board assembly version will be printed on a label, usually attached to the bottom side. The assembly version will be the letter designation following the schematic revision: 700-29683 REV _.

2. Specifications

This section provides the detailed information about the electrical design and practical considerations that go into the MEK board. **Figure 1** describes each block in the high-level block diagram of the MEK board.

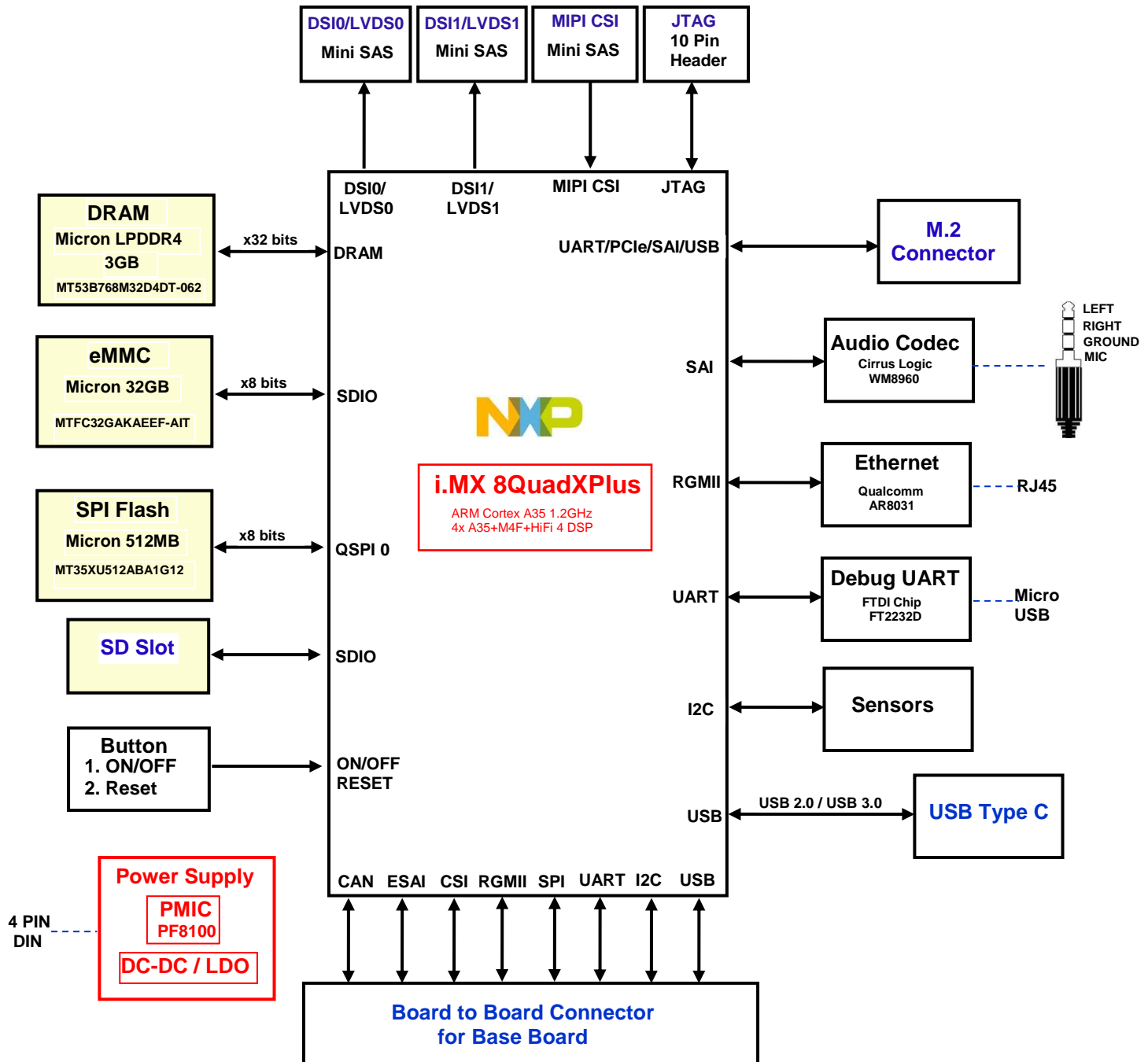

Figure 1. MCIMX8QXP-MEK block diagram

Figure 2 shows the overview of the i.MX 8QuadXPlus MEK board.

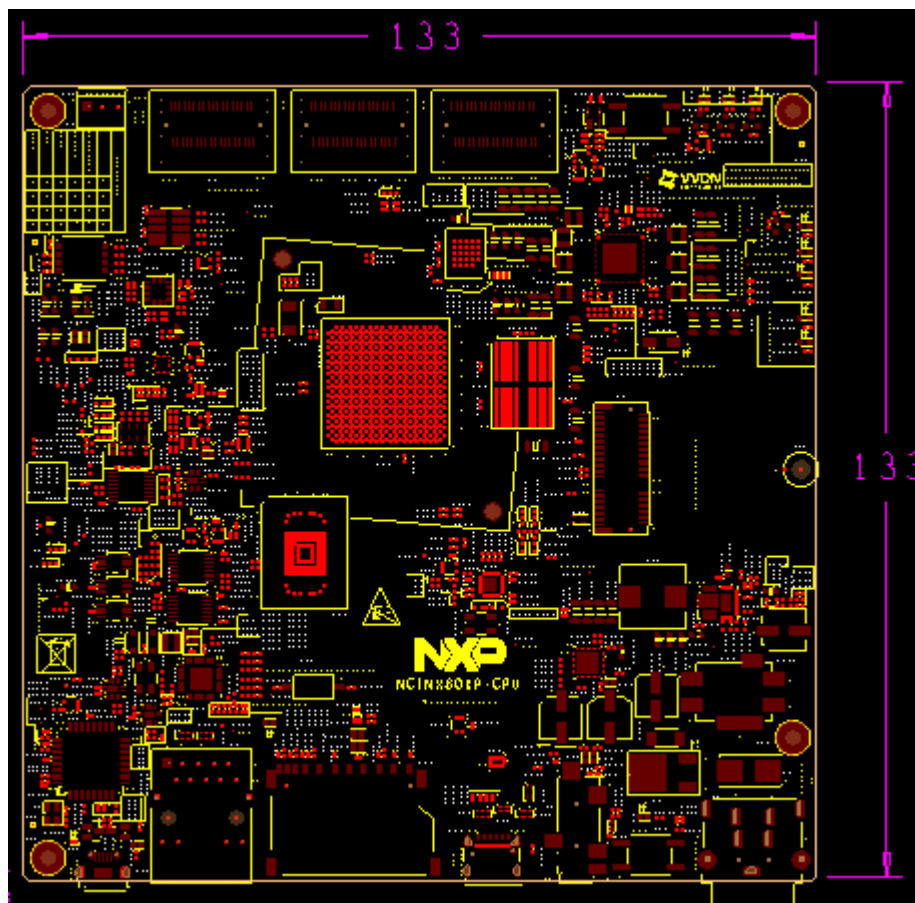

Figure 2. i.MX 8QuadXPlus MEK board overview

2.1. Processor

The i.MX 8QuadXPlus processors represent NXP Semiconductor's latest achievement in integrated multimedia-focused products offering high performance processing with a high degree of functional integration, targeted towards the growing market of connected devices. The i.MX 8QuadXPlus processor features NXP's advanced implementation of the Quad Arm Cortex[®]-A35+ Arm Cortex[®]-M4 core, which operates at speeds up to 1.2 GHz. Each processor provides a 32-bit DDR3L/LPDDR4 memory interface and other interfaces for connecting peripherals, such as WLAN, Bluetooth[™], GPS and camera sensors.

For more detailed information about the processor, please refer to the datasheet and reference manual on www.nxp.com/imx8X.

2.2. Boot mode operations and selections

The MEK board based on i.MX 8QuadXPlus Applications Processor is provided with a boot selection switch (SW2) for determining the boot source device. The user can adjust the various switch positions and select boot device as shown in [Table 2](#).

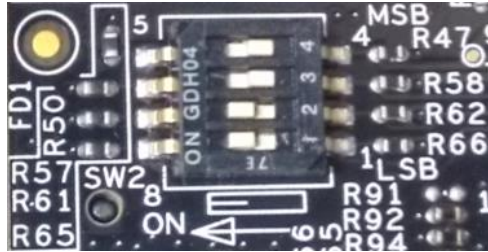

Figure 3. Boot mode selection using SW2

Table 2. Boot selection

BOOT_MODE 3	BOOT_MODE 2	BOOT_MODE 1	BOOT_MODE 0	Boot Device
0	0	0	0	BOOT From Fuse
0	0	0	1	Serial Download
0	0	1	0	EMMC0
0	0	1	1	SD1
0	1	1	0	Serial NOR flash 3B Read
0	1	1	1	Hyperflash 3.3V

On the i.MX 8QuadXPlus MEK board, the default boot mode is from SD card.

2.3. Power tree

There is a +12 V external wall power supply that needs to be connected to the i.MX 8QuadXPlus MEK board at connector J9. The other powers are generated in the MEK board using PMIC, DC to DC converters and LDOs. [Figure 4](#) shows the power tree.

Table 3. Power Rails

SEQ	PWR Rail	SRC Type	Value
3	VCC_SNVS	PMIC PF8100	3.0
4	VCC_SCU_1V8	PMIC PF8100	1.8
5	VCC_LDO_SD1	PMIC PF8100	3.3/1.8
4	VCC_MAIN	PMIC PF8100	1.0
8	VCC_GPU	PMIC PF8100	1.1

7	VCC_CPU	PMIC PF8100	1.1
5	VCC_DDRIO	PMIC PF8100	1.1
5	VCC_3V3	PMIC PF8100	3.3
5	VCC_1V8	PMIC PF8100	1.8
2	VCC_EXT_5V0	DC/DC BUCK	5.0
2	VCC_EXT_3V3	DC/DC BUCK	3.3
6	VCC_EXT_1V8	DC/DC BUCK	1.8
1	VCC_12V0	DC Input	12

In *Figure 4*, the developer can get all the voltage supply rails used on the MEK board. When some modules are not working, the developer needs to test whether the voltage of this module is correct.

Table 3 lists the power rails on the board.

Specifications

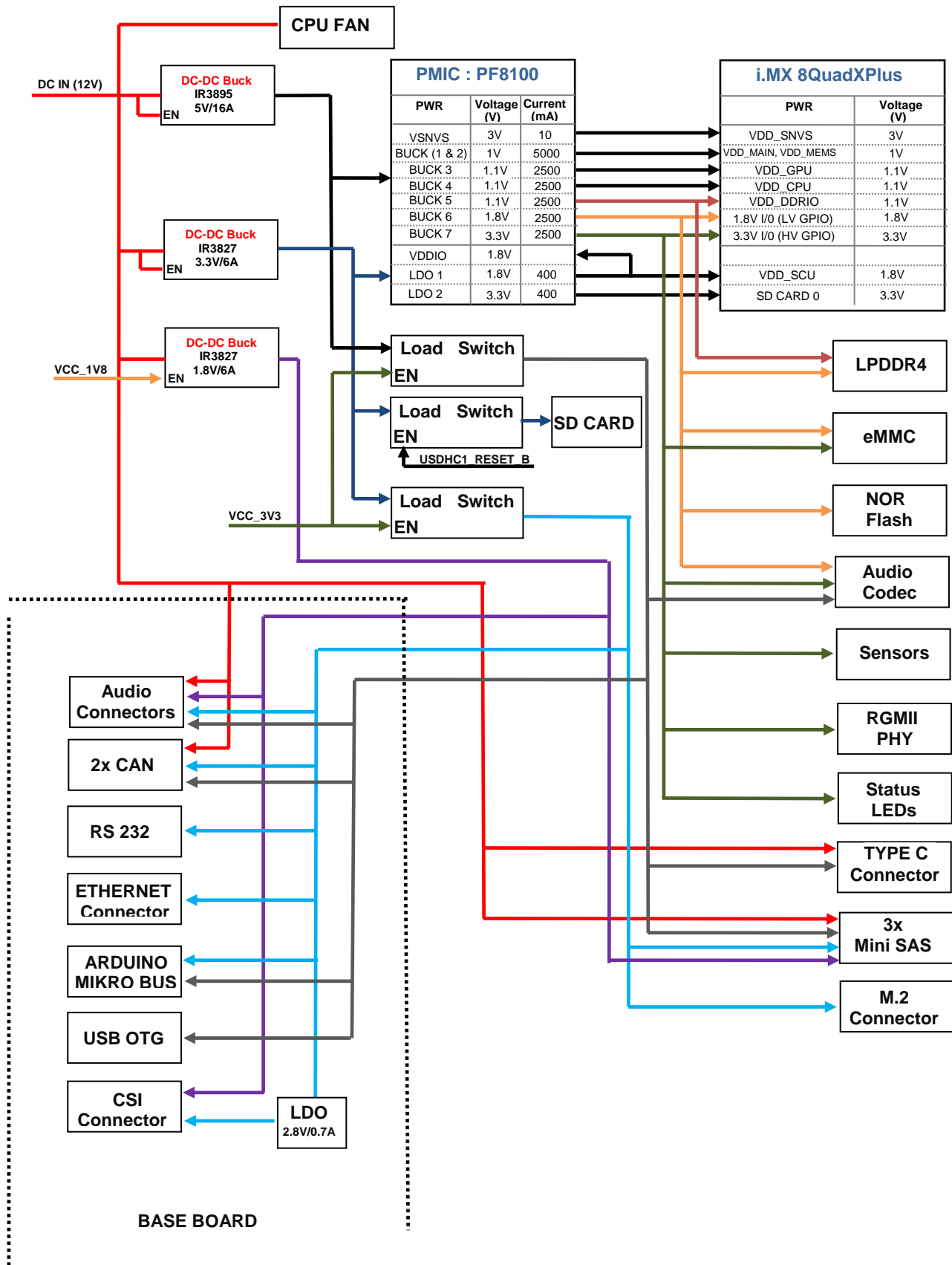

.....
Figure 4. Power tree diagram

2.4. LPDDR4 DRAM memory

The i.MX 8QuadXPlus MEK board has one 768 Meg × 32 (4 channels × 16 I/O) LPDDR4 SDRAM chip (MT53B768M32D4DT-062 AIT:B) for a total of 3 GB RAM memory.

In the physical layout, the LPDDR4 chip is placed on the TOP side, the data traces are not necessarily connected to the LPDDR4 chips in sequential order, but for ease of routing, are connected as best determined by the layout and other critical traces.

2.5. SD card slot (J12)

There is one SD card connector (J12) on the i.MX 8QuadXPlus MEK board. This SD card is connected to USDHC1 of the i.MX 8QuadXPlus application processor. By default, this SD connector supports one 4-bit SD3.0 card.

2.6. eMMC memory (U23)

The eMMC interface is connected to EMMC0 of i.MX 8QuadXPlus. It can support eMMC 5.0. To boot from eMMC, the Boot-mode switch (SW2) should be changed as shown in [Table 2](#)

2.7. Ethernet connector (J7)

There is one gigabit Ethernet module on the i.MX 8QuadXPlus processor. The developer can use the ENET connector to send/receive the ENET signals. The Ethernet subsystem of the i.MX 8QuadXPlus MEK board is provided by the Qualcomm AR8031 Ethernet Transceiver (U30). The Ethernet Transceiver (or PHY) receives standard RGMII Ethernet signals from the i.MX 8QuadXPlus Applications Processor. The processor takes care of all Ethernet protocols at the MAC layer and above. The PHY is only responsible for the Link Layer formatting.

The MAC address is set on the MEK board before shipping to the developer and the same is printed on the SD slot on the Top side of the MEK Board.

2.8. USB Type-C connector (J10)

The i.MX 8QuadXPlus MEK board has a USB Type-C connector on the Top side. The i.MX 8QuadXPlus application processor has a specified USB3/USB2 OTG module to perform USB 3.0 dual-role and USB 2.0 On-The-Go (OTG) compatible with the USB 3.0 specification. The processor has an additional separate, independent USB 2.0 OTG controller which can be used simultaneously with this USB 3.0.

The USB_SS3 and the USB_OTG2 are connected to the USB type C connector in the MEK board. The USB_OTG1 is connected to the USB OTG connector in the base board.

2.9. Audio input/output (J8)

i.MX 8QuadXPlus MEK board includes one Headphone + Mic connector (J8). J8 is a 3.5 mm audio jack with AHJ pin out. (Rev.D uses AHJ, but previous versions (up to C2) used OMTP pin out).

The Audio codec used on the MEK board is CIRRUS LOGIC Low Power, high quality Stereo codec, WM8960. The digital interface between i.MX 8QuadXPlus processor and WM8960 includes four signals: SAI1_TXD, SAI1_RXD, SAI1_TXC, and SAI1_TXFS. The i.MX 8QuadXPlus also provides the MCLK to WM8960.

2.10. UART connector (J11)

The i.MX 8QuadXPlus MEK Rev.C Board has two independent UART Ports (UART0, M40_UART0) for debugging. A USB to serial UART converter IC (FT2232D) is used in the MEK board for converting the USB signals to UART signals. Make sure the FT2232D driver has been installed on your computer for proper operation. If not, you may download it from FTDICHIP website and install:

<https://www.ftdichip.com/Products/ICs/FT2232D.htm>

On the MEK board, UART0_TX & UART0_RX are used to output serial debugging information for A35-core. M40_UART0_TX & M40_UART0_RX are used to output serial debugging information for M4-core. No RTS or CTS signals are sent from the Processor to the Debug connector as these signals are ignored by most applications. The required terminal settings to receive debug information during the boot cycle are as shown in *Table 4*

Table 4. Terminal setting parameters

Data Rate	115,200 Baud
Data bits	8
Parity	None
Stop bits	1

2.11. JTAG connector (J4)

The i.MX 8QuadXPlus Applications Processor accepts four JATG signals from an attached debugging device on dedicated pins. The five JTAG signals used by the processor are:

- JTAG_TCK TAP Clock
- JTAG_TMS TAP Machine State
- JTAG_TDI TAP Data In
- JTAG_TDO TAP Data Out

The fifth signal from the attached debugging device (JTAG_SRST_B) is connected to the Reset generation circuit on the MEK board.

2.12. M.2 Connector (J5)

The i.MX8QuadXPlus Application processor has only one PCIe interface. It is connected to the M.2 connector with E-Key on the MEK Board. Other interfaces connected to the M.2 connector are UART, USB, I2C and SAI.

The M.2 connector is mainly provided on the MEK board for interfacing with various Wi-Fi/Bluetooth adapter cards having M.2 form factor.

2.13. MIPI- CSI and MIPI-DSI/LVDS connectors (J1,J2,J3)

The i.MX 8QuadXPlus processor supports dual MIPI-DSI/LVDS and single MIPI-CSI. The connectors are designed to support camera and display daughter cards developed by NXP. The connectors are as shown in [Figure 5](#).

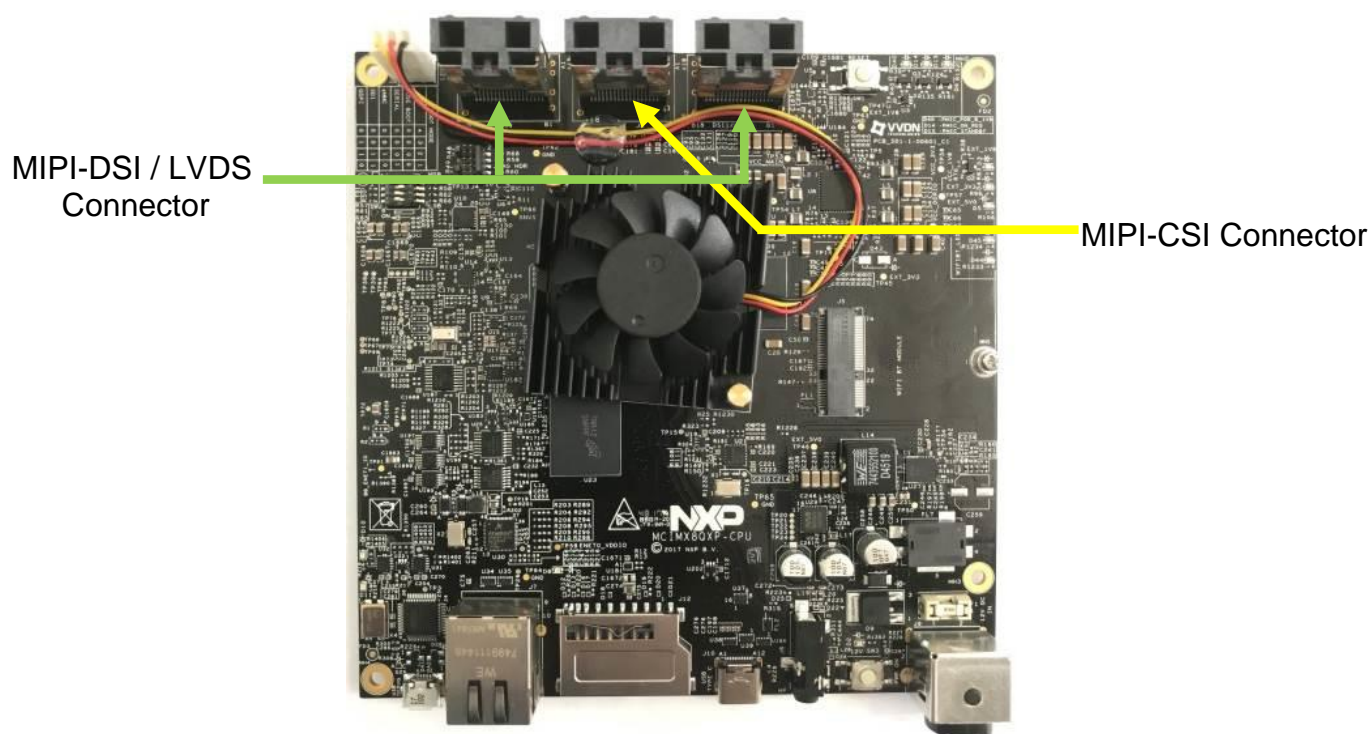

Figure 5. MIPI-CSI and MIPI-DSI/LVDS connectors

2.14. Board to Board connector (J13)

The i.MX8QuadXPlus MEK board has a Board to Board connector on the bottom side for connecting with the Base board (Need to order separately, MPN :MCIMX8-8X-BB). The following interface signals of i.MX8QuadXPlus applications processor are connected to the board to board connector to use with the base board.

- CAN
- Audio (ESAI)
- Parallel Camera Interface
- RGMII
- USB OTG
- LCD (Multiplexed with ESAI)
- Tamper (Multiplexed with Camera interface)
- SPI
- I2C
- UART

2.15. User interface buttons

There are two user interface buttons on the MEK board.

2.15.1. ON/OFF Button (SW3)

The chip supports the use of a button input signal to request main SoC power state changes (i.e. ON or OFF) from the PMU.

In the ON state, if ON/OFF button is held longer than the 5 s, the power-off interrupt is generated. In the OFF state, if ON/OFF button is held longer than the 0.5 s, the state will transit from OFF to ON.

2.15.2. Reset button (SW1)

In the ON state, holding the RESET button (SW1) will force to reset the power rails except the VDD_SNVS on the i.MX 8QuadXPlus MEK board. The reset signal from SW1 is connected to the WDI pin of the PMIC. Once the button is pressed, the PMIC will turn off the powers and generate a POR signal to the processor and the peripherals. The i.MX 8QuadXPlus applications processor will be immediately turned off and reinitiate a boot cycle from the OFF state.

2.16. User Interface LEDs

The following LEDs are provided on the MEK board for status indication.

Table 5. Status Indication LEDs

LED	DESCRIPTION
D40	Processor RESET status ON : i.MX 8QuadXPlus is in Reset State , OFF : i.MX 8QuadXPlus is in Active State
D14	SCU PMIC ON request ON : PMIC is ON , OFF : PMIC is OFF
D15	SCU PMIC Standby ON : PMIC is in Standby mode , OFF : PMIC is in operational mode
D8	Ethernet Speed Indication, ON : 1Gbps, OFF : 10/100Mbps
D2	12V Supply ON
D3	EXT_1V8 Supply ON
D4	EXT_3V3 Supply ON
D5	EXT_5V0 Supply ON
D44	According to M.2 module behavior
D45	According to M.2 module behavior

2.17. Sensors

The i.MX 8QuadXPlus MEK board has four sensors: Accelerometer + Magnetometer (FXOS8700CQ), Pressure Sensor with Altimetry (MPL3115A2), Ambient light sensor (ISL29023IROZ) and Gyroscope (FXAS21002CQ). These four sensors are connected to i.MX8QuadXPlus I2C port.

2.17.1 Accelerometer + Magnetometer (U14)

The Accelerometer + Magnetometer IC, FXOS8700CQ from NXP Semiconductors, is a small, low-power, 3-axis, linear accelerometer and 3-axis, magnetometer combined into a single package. The device features a selectable I2C or point-to-point SPI serial interface with 14-bit accelerometer and 16-bit magnetometer ADC resolution along with smart-embedded functions.

2.17.2 Pressure Sensor with Altimetry (U18)

The Pressure sensor with Altimetry, MPL3115A2 from NXP Semiconductors, is a compact, piezo resistive, absolute pressure sensor with an I2C digital interface. MPL3115A2 has a wide operating

range of 20 kPa to 110 kPa, a range that covers all surface elevations on earth. MPL3115A2's advanced ASIC has multiple user programmable modes such as power saving, interrupt and autonomous data acquisition modes, including programmed acquisition cycle timing, and poll-only modes.

2.17.3 Ambient Light Sensor (U17)

The Ambient light sensor, ISL29023 from INTERSIL, is an integrated ambient and infrared light to digital converter with I2C (SMBus Compatible) Interface. Its advanced self-calibrated photodiode array emulates human eye response with excellent IR rejection. The on-chip ADC is capable of rejecting 50Hz and 60Hz flicker caused by artificial light sources. The lux range select feature allows users to program the lux range for optimized counts/lux.

2.17.4 Gyroscope (U10)

The Gyroscope IC, FXAS21002C from NXP Semiconductors, is a small, low-power, yaw, pitch, and roll angular rate gyroscope with 16 bit ADC resolution. The full-scale range is adjustable from $\pm 250^\circ/\text{s}$ to $\pm 2000^\circ/\text{s}$. It features both I2C and SPI interfaces.

2.18. PCB information

The overall dimensions of the i.MX 8QuadXPlus MEK board PCB are shown in [Figure 2](#). The MEK board is made with standard 8-layer technology. The material used is TU872-SLK Sp, and the PCB stack-up information is shown in [Table 6](#).

Table 6. Board stack up information

Layer	Description	Copper (Oz.)	Dielectric thickness (mil)
1	Signal	1	
	Dielectric		3.5
2	GND	1	
	Dielectric		3
3	Signal	1	
	Dielectric		8
4	Power	2	
	Dielectric		18
5	Power	2	
	Dielectric		8
6	Signal	1	
	Dielectric		3
7	GND	1	
	Dielectric		3.5
8	Signal	1	

2.19. MEK design files

You can download the schematics, layout file, Gerber files, and BOM from www.nxp.com/imx8X.

3. MEK Accessories

For developers' wishing to expand the MEK board, can purchase the following optional accessory boards from NXP website.

To implement display or camera functionality through MIPI-DSI/CSI interface, NXP provides 4 accessories that can be directly attached to the mini-SAS connector on MEK board. The IMX-LVDS-HDMI board is included the MEK board kit. The developer can purchase other three accessories from NXP website.

[Table 7](#) shows the link to each accessory, in which you can find the user guide and design files of the accessory.

Table 7. Links to accessories for the i.MX8QuadXPlus MEK

Accessory	Description	Link
IMX-MIPI-HDMI	Converts MIPI-DSI signal to HDMI signal	https://www.nxp.com/part/IMX-MIPI-HDMI
MX8-DSI-OLED1	MIPI-DSI interface OLED display kit with touch screen	https://www.nxp.com/part/MX8-DSI-OLED1
MINISASTOCSI	MIPI-CSI interface camera kit based on OmniVision chipset OV5640	https://www.nxp.com/part/MINISASTOCSI
IMX-LVDS-HDMI	Converts LVDS signal to HDMI signal	https://www.nxp.com/part/IMX-LVDS-HDMI

NOTE

Contact Marketing or Sales for operational boards

4. Revision History

Table 8 summarizes the changes made to this document since the initial release.

Table 8. Revision history

Revision number	Date	Substantive changes
0	11/2018	Initial release.
1	01/2019	Updates in Section 2.10

How to Reach Us:

Home Page:
www.nxp.com/

Web Support:
www.nxp.com/support

Information in this document is provided solely to enable system and software implementers to use NXP products. There are no express or implied copyright licenses granted hereunder to design or fabricate any integrated circuits based on the information in this document. NXP reserves the right to make changes without further notice to any products herein.

NXP makes no warranty, representation, or guarantee regarding the suitability of its products for any particular purpose, nor does NXP assume any liability arising out of the application or use of any product or circuit, and specifically disclaims any and all liability, including without limitation consequential or incidental damages. "Typical" parameters that may be provided in NXP data sheets and/or specifications can and do vary in different applications, and actual performance may vary over time. All operating parameters, including "typicals," must be validated for each customer application by customer's technical experts. NXP does not convey any license under its patent rights nor the rights of others. NXP sells products pursuant to standard terms and conditions of sale, which can be found at the following address: nxp.com/SalesTermsandConditions.

While NXP has implemented advanced security features, all products may be subject to unidentified vulnerabilities. Customers are responsible for the design and operation of their applications and products to reduce the effect of these vulnerabilities on customer's applications and products, and NXP accepts no liability for any vulnerability that is discovered. Customers should implement appropriate design and operating safeguards to minimize the risks associated with their applications and products.

NXP, the NXP logo, NXP SECURE CONNECTIONS FOR A SMARTER WORLD, COOLFLUX, EMBRACE, GREENCHIP, HITAG, I2C BUS, ICODE, JCOP, LIFE VIBES, MIFARE, MIFARE CLASSIC, MIFARE DESFire, MIFARE PLUS, MIFARE FLEX, MANTIS, MIFARE ULTRALIGHT, MIFARE4MOBILE, MIGLO, NTAG, ROADLINK, SMARTLX, SMARTMX, STARPLUG, TOPFET, TRENCHMOS, UCODE, Freescale, the Freescale logo, Altivec, C 5, CodeTEST, CodeWarrior, ColdFire, ColdFire+, C Ware, the Energy Efficient Solutions logo, Kinetis, Layerscape, MagniV, mobileGT, PEG, PowerQUICC, Processor Expert, QorIQ, QorIQ Qonverge, Ready Play, SafeAssure, the SafeAssure logo, StarCore, Symphony, VortiQa, Vybrid, Airfast, BeeKit, BeeStack, CoreNet, Flexis, MXC, Platform in a Package, QUICC Engine, SMARTMOS, Tower, TurboLink, and UMEMS are trademarks of NXP B.V. All other product or service names are the property of their respective owners. Arm, AMBA, Arm Powered, Artisan, Cortex, Jazelle, Keil, SecurCore, Thumb, TrustZone, and μ Vision are registered trademarks of Arm Limited (or its subsidiaries) in the EU and/or elsewhere. Arm7, Arm9, Arm11, big.LITTLE, CoreLink, CoreSight, DesignStart, Mali, Mbed, NEON, POP, Sensinode, Socrates, ULINK and Versatile are trademarks of Arm Limited (or its subsidiaries) in the EU and/or elsewhere. All rights reserved. Oracle and Java are registered trademarks of Oracle and/or its affiliates. The Power Architecture and Power.org word marks and the Power and Power.org logos and related marks are trademarks and service marks licensed by Power.org.

© 2018-2019 NXP B.V.

Document Number:IMX8QXPMEKHUG
Rev. 1
01/2019





Стандарт Электрон Связь

Мы молодая и активно развивающаяся компания в области поставок электронных компонентов. Мы поставляем электронные компоненты отечественного и импортного производства напрямую от производителей и с крупнейших складов мира.

Благодаря сотрудничеству с мировыми поставщиками мы осуществляем комплексные и плановые поставки широчайшего спектра электронных компонентов.

Собственная эффективная логистика и склад в обеспечивает надежную поставку продукции в точно указанные сроки по всей России.

Мы осуществляем техническую поддержку нашим клиентам и предпродажную проверку качества продукции. На все поставляемые продукты мы предоставляем гарантию .

Осуществляем поставки продукции под контролем ВП МО РФ на предприятия военно-промышленного комплекса России , а также работаем в рамках 275 ФЗ с открытием отдельных счетов в уполномоченном банке. Система менеджмента качества компании соответствует требованиям ГОСТ ISO 9001.

Минимальные сроки поставки, гибкие цены, неограниченный ассортимент и индивидуальный подход к клиентам являются основой для выстраивания долгосрочного и эффективного сотрудничества с предприятиями радиоэлектронной промышленности, предприятиями ВПК и научно-исследовательскими институтами России.

С нами вы становитесь еще успешнее!

Наши контакты:

Телефон: +7 812 627 14 35

Электронная почта: sales@st-electron.ru

Адрес: 198099, Санкт-Петербург,
Промышленная ул, дом № 19, литера Н,
помещение 100-Н Офис 331