

## Description

The AP3917D is a universal AC voltage step-down power switcher, which is specially designed for home appliance and IoT applications with non-isolated buck solution or offline flyback solution.

The device integrates a 700V high performance Power MOSFET. Coordinating with a single-winding inductor, it uses fewer external components and provides a low Bill Of Material (BOM) cost solution.

The AP3917D can achieve excellent regulation and high power efficiency. The peak current and switching frequency continuously reduce as the load decreases, so it can get excellent efficiency performance at light load and improve the overall system efficiency.

The AP3917D has multiple protection features to enhance the system safety and reliability. It has over temperature protection, under-voltage lock function, output short protection, overload protection, and open-loop protection.

The AP3917D is available in the SO-7 package.

## Features

- Universal 85V<sub>AC</sub> to 265V<sub>AC</sub> Input Range
- Internal MOSFET of 700V
- Maximal Peak Current: 500mA Typical
- Improved Constant Voltage: ±5%
- Maximum 300mA Rated Output Current
- No Load Power Consumption: < 30mW with External Bias
- Frequency Modulation to Suppress EMI
- Various Protections: OTP (Over Temperature Protection), OLP (Over Load Protection), SCP (Short Circuit Protection)
- Fewer Components
- Low Audible Noise Solution
- SO-7 Package
- **Totally Lead-Free & Fully RoHS Compliant (Notes 1 & 2)**
- **Halogen and Antimony Free. "Green" Device (Note 3)**

- Notes:
1. No purposely added lead. Fully EU Directive 2002/95/EC (RoHS), 2011/65/EU (RoHS 2) & 2015/863/EU (RoHS 3) compliant.
  2. See <https://www.diodes.com/quality/lead-free/> for more information about Diodes Incorporated's definitions of Halogen- and Antimony-free, "Green" and Lead-free.
  3. Halogen- and Antimony-free "Green" products are defined as those which contain <900ppm bromine, <900ppm chlorine (<1500ppm total Br + Cl) and <1000ppm antimony compounds.

## Pin Assignments

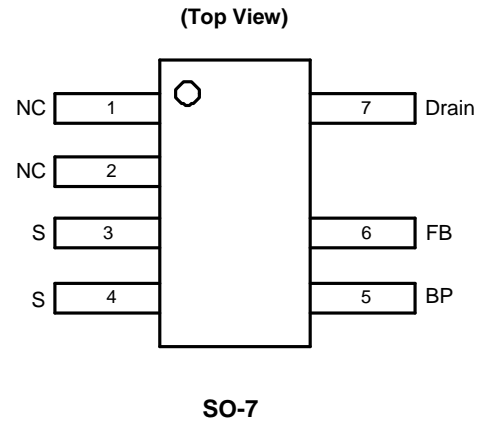

## Applications

- Non-Isolated Home Appliances: AC Fans, Rice Cookers, Shavers; Milk Machines
- IoT Applications
- Industrial Controls
- Standby and Auxiliary

**Typical Applications Circuit**

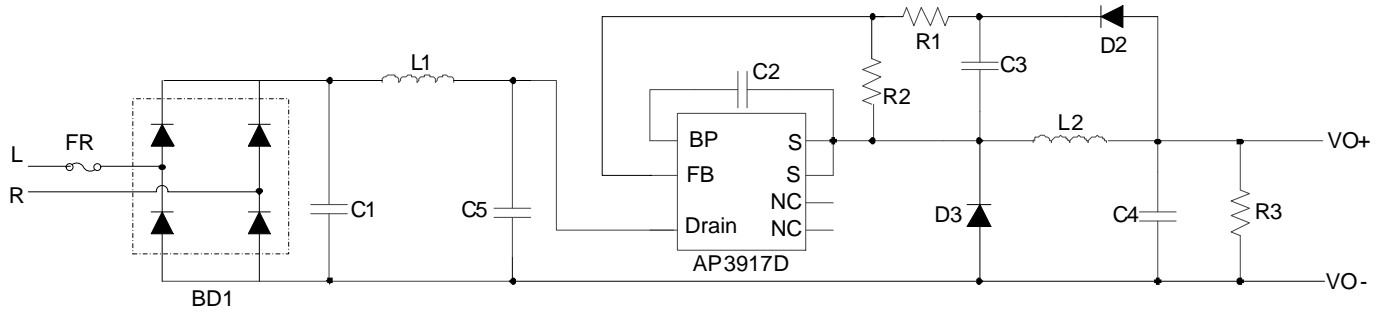

**Pin Descriptions**

Pin Number	Pin Name	Function
1, 2	N/C	Not Connected.
3,4	S	Internal Power MOSFET Source. Ground Reference for BP and FB Pins.
5	BP	Connection Point of External Bypass Capacitor for Internally Generated Control Circuit Power Supply.
6	FB	Regulator Feedback.
7	Drain	Internal Power MOSFET Drain. High-Voltage Current Source Input.

**Functional Block Diagram**

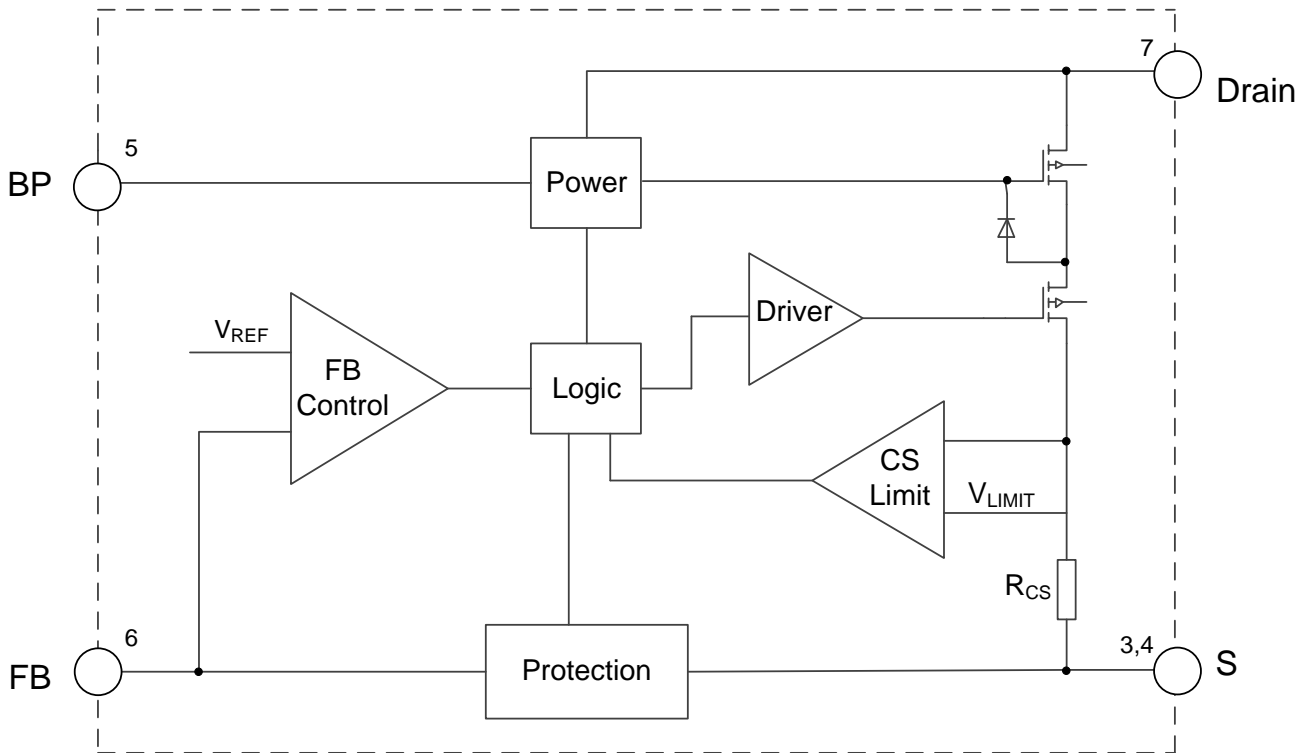

NEW PRODUCT

## Absolute Maximum Ratings (Note 4)

Symbol	Parameter	Rating	Unit
$V_{DSS}$	Drain Pin Voltage	-0.7 to 700	V
$V_{BP}$	Internally Generated Control Circuit Power Supply	8.9	V
$V_{FB}, V_S$	FB Pin Voltage and S Pin Voltage	-0.7 to 5.5	V
$P_D$	Continuous Power Dissipation ( $T_A = +25^\circ\text{C}$ )	1	W
$T_J$	Operating Junction Temperature	+125	$^\circ\text{C}$
$T_{STG}$	Storage Temperature	-65 to +150	$^\circ\text{C}$
$T_{LEAD}$	Lead Temperature (Soldering, 10s)	+300	$^\circ\text{C}$
$\theta_{JA}$	Thermal Resistance (Junction to Ambient) (Note 5)	91	$^\circ\text{C}/\text{W}$
—	ESD (Human Body Model)	4000	V
—	ESD (Charge Device Model)	1000	V

- Note: 4. Stresses greater than those listed under *Absolute Maximum Ratings* can cause permanent damage to the device. These are stress ratings only, and functional operation of the device at these or any other conditions beyond those indicated under *Recommended Operating Conditions* is not implied. Exposure to *Absolute Maximum Ratings* for extended periods can affect device reliability.
5. Test condition: Device mounted on FR-4 substrate PC board, 2oz copper, with 1inch<sup>2</sup> cooling area.

## Recommended Operating Conditions

Symbol	Parameter	Min	Max	Unit
$V_{BP}$	Supply Voltage	8.2	8.8	V
$V_{DSS}$	Drain-Source Voltage (Note 6)	—	560	V
$T_A$	Ambient Temperature	-40	+125	$^\circ\text{C}$

- Note: 6. The drain-source voltage is 80% of  $V_{DS}$  in the aging condition.

**Electrical Characteristics** ( $V_{BP} = 8.2V$ ,  $-40^{\circ}C < T_A < +125^{\circ}C$ , unless otherwise specified.)

Symbol	Parameter	Condition	Min	Typ	Max	Unit
<b>HV Startup Current Source</b>						
$I_{HV}$	HV Supply Current	$V_{BP} = 7V$ , $V_{DRAIN} = 100V$	—	3.5	—	mA
$I_{LEAK}$	Leakage Current of Drain	$V_{BP} = 8.7V$ ; $V_{DRAIN} = 400V$ , $T_A = +25^{\circ}C$	—	10	12	$\mu A$
<b><math>V_{BP}</math> Voltage Management</b>						
$V_{BP\_HVOFF}$	$V_{BP}$ Increasing Level at which HV Supply is OFF	—	8.1	8.5	8.8	V
$V_{BP\_HVON}$	$V_{BP}$ Decreasing Level at which HV Supply is ON	—	7.8	8.2	8.6	V
$V_{BP\_HYS}$	$V_{BP}$ Hysteresis ( $V_{BP\_HVOFF} - V_{BP\_HVON}$ )	—	—	280	—	mV
$V_{BP\_UVLO}$	$V_{BP}$ Minimum Operating Voltage	$T_A = +25^{\circ}C$	—	6.5	—	V
$V_{BP\_RESTART}$	$V_{BP}$ Restart Voltage	—	—	4.5	—	V
$I_{BP1}$	$V_{BP}$ Operating Current with MOSFET Switching	$V_{BP} = 8.5V$ , $f = 37kHz$ , $D = 40%$ , $T_A = +25^{\circ}C$	—	—	350	$\mu A$
$I_{BP2}$	$V_{BP}$ Quiescent Current with No Switching	$T_A = +25^{\circ}C$	—	110	200	$\mu A$
$I_{BP\_LATCH}$	$V_{BP}$ Latch Off-Current	$V_{BP} = 8.8V$ , $T_A = +25^{\circ}C$	—	26	—	$\mu A$
<b>Internal MOSFET</b>						
$V_{DS}$	Breakdown Voltage	(Note 6) $T_A = +25^{\circ}C$	700	—	—	V
$R_{DS(ON)}$	ON Resistance	$T_A = +25^{\circ}C$	—	—	10.5	$\Omega$
		$T_A = +125^{\circ}C$	—	—	30	
<b>Internal Current Sense</b>						
$I_{PK\_MAX}$	Maximum Peak Current	$T_A = +25^{\circ}C$	413	500	600	mA
$t_{LEB1}$	Leading-Edge Blanking	$T_A = +25^{\circ}C$	—	250	400	ns
$I_{SCP}$	Current Set Point for Short Circuit Protection	$T_A = +25^{\circ}C$	—	800	—	mA
$t_{LEB2}$	Leading-Edge Blanking for Short Circuit Protection	$T_A = +25^{\circ}C$	—	200	—	ns
<b>Feedback Input (FB Pin)</b>						
$t_{MINOFF}$	Minimum Off-Time	$T_A = +25^{\circ}C$	10.5	15.5	18.5	$\mu s$
$V_{FB}$	Feedback Voltage for MOSFET Switch-On Threshold	—	2.4	2.5	2.6	V
$V_{FB\_OLP}$	Feedback Voltage for Over Load Protection Trigger Threshold	—	1.56	1.7	1.84	V
$t_{OLP}$	Over Load Protection Delay Time	$f = 36kHz$	—	170	—	ms
$V_{OLD}$	Open-Loop Detection Voltage	$T_A = +25^{\circ}C$	—	60	—	mV
$t_{OLD}$	Open-Loop Detection Blanking Time	$f = 15kHz$ , $T_A = +25^{\circ}C$	—	4.3	—	ms
<b>Over Temperature Protection</b>						
$T_{OTP}$	Thermal Shutdown Threshold	—	+135	+150	+165	$^{\circ}C$

Note: 6. The drain-source voltage is 80% of  $V_{DS}$  in the aging condition.

**Performance Characteristics**

NEW PRODUCT

**FB Voltage vs. Ambient Temperature**

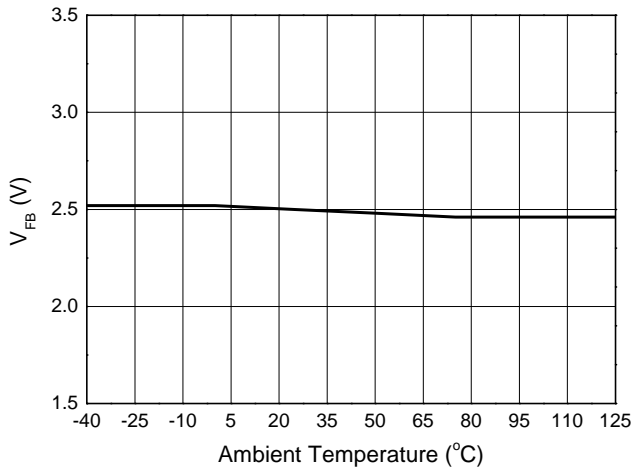

**V<sub>BP\_HVON</sub> Voltage vs. Ambient Temperature**

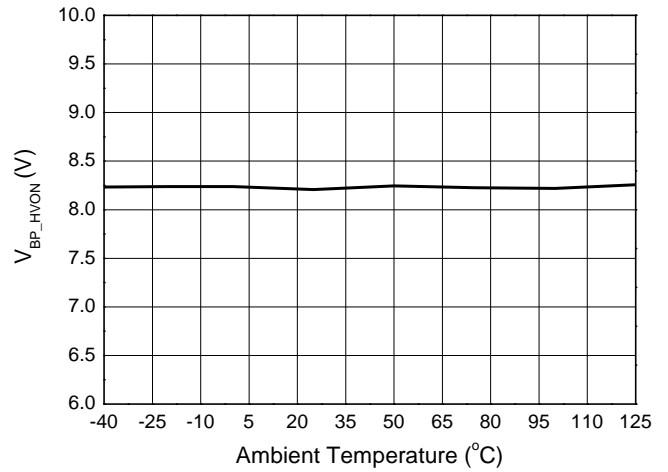

**V<sub>BP\_HVOFF</sub> Voltage vs. Ambient Temperature**

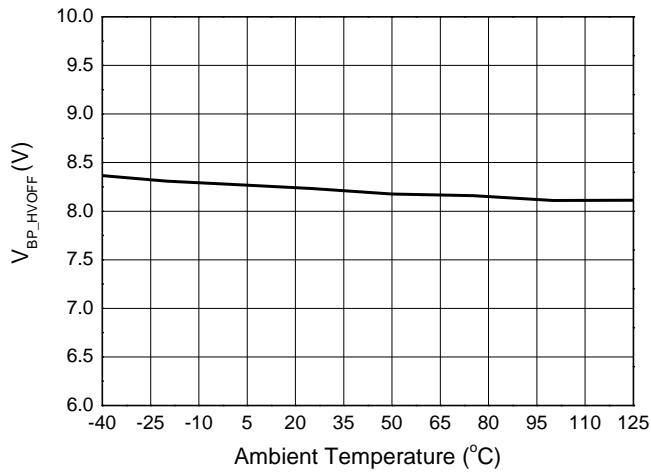

**R<sub>DS(ON)</sub> vs. Ambient Temperature**

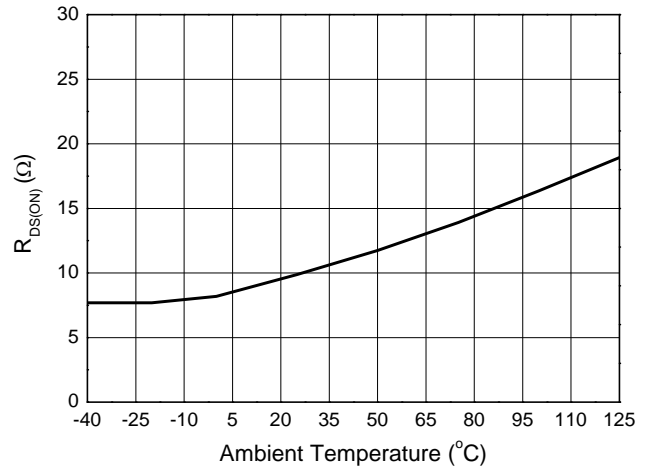

**Performance Characteristics** (continued)

**Overall Introduction**

The AP3917D is a universal AC input step-down power switcher. Peak current and switching frequency reduce as the load decreases, so the device can get excellent efficiency performance at light load and improve the overall system efficiency. Coordinating with an external single-winding inductor can achieve a low BOM cost solution.

**V<sub>BP</sub> Waveform and ON/OFF Control**

The AP3917D control circuit power supply voltage V<sub>BP</sub> is charged by the internal high-voltage regulator. When the BP voltage is charged to V<sub>BP\_HVOFF</sub> (8.5V), the IC starts up, and the internal high-voltage regulator is turned off. When the BP voltage drops below V<sub>BP\_HVON</sub> (8.2V), the internal high-voltage regulator turns on again to charge the external BP capacitor.

When fault conditions happen, such as some protections like overload faults, short-circuit faults, over temperature faults, and open-loop faults, the AP3917D stops switching. Afterwards an internal current source I<sub>BP\_LATCH</sub> discharges the external BP capacitor. The internal high-voltage regulator will not turn on again until the voltage on BP capacitor drops below V<sub>BP\_RESTART</sub> (4.5V). The restart time interval is proportional to the capacitance of external BP capacitor—the larger capacitance of the external BP capacitor, the longer restart time.

The restart time after a fault is about

$$t_{RESTART} = C_{BP} \times \left( \frac{V_{BP\_FAULT} - V_{BP\_RESTART}}{I_{BP\_LATCH}} + \frac{V_{BP\_HVOFF} - V_{BP\_RESTART}}{I_{HV}} \right)$$

Where:

- V<sub>BP\_FAULT</sub> is actual voltage value of BP pin at the time of fault, which is between V<sub>BP\_HVON</sub> and V<sub>BP\_HVOFF</sub>

Figure 1 shows the typical waveform of V<sub>BP</sub>.

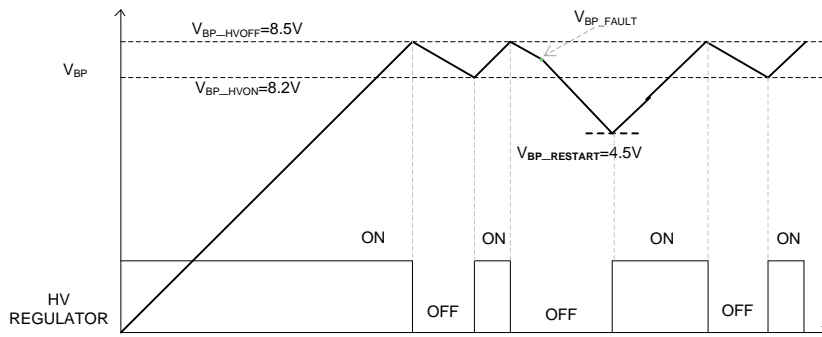

Figure 1. V<sub>BP</sub> Waveform and HV Regulator ON/OFF Status

**Auxiliary V<sub>BP</sub> Supply**

If the output voltage is higher than the voltage of V<sub>BP\_HVON</sub>, an auxiliary V<sub>BP</sub> supply can be implemented to reduce overall power consumption by connecting a resistor (R4) between C2 and C3. A standby power of less than 30mW can be achieved especially in a no-load condition.

Figure 2 shows the low standby power circuit with the auxiliary V<sub>BP</sub> supply.

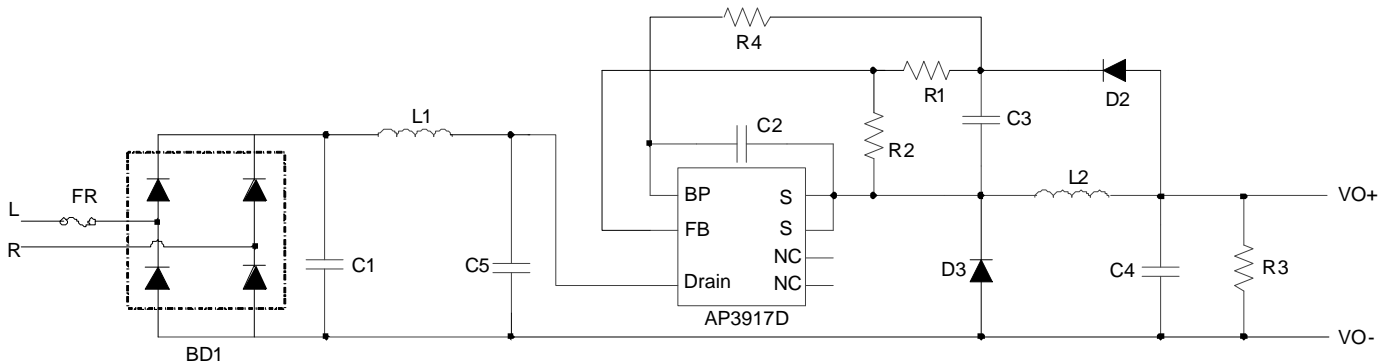

Figure 2. Low Standby Power Circuit With Auxiliary V<sub>BP</sub> Supply

**Performance Characteristics** (continued)

The value of R4 can be determined by the following equation:

$$R4 = \frac{V_O - V_{BP\_HVON}}{I_{BP2}}$$

**Constant Voltage Operation**

The AP3917D can be used in a buck circuit as shown in the typical application circuit. In the beginning of each cycle, the internal integrated MOSFET turns ON when the FB voltages fall below the reference voltage  $V_{FB}$  (2.5V). The FB voltage is derived from the sampling capacitor voltage, which can reflect output voltage.

The ON period time is determined by the inductor current variable value  $\Delta I_L$ , ( $\Delta I_L$  is the gap of the peak-current limitation value  $I_{PK}$  and the initial inductor current value  $I_{INI}$ ), the inductance value, and the input voltage. The ON time calculation is as follows:

$$t_{ON} = L \cdot \frac{\Delta I_L}{V_{IN\_DC}} = L \cdot \frac{I_{PK} - I_{INI}}{V_{IN\_DC}}$$

Where  $I_{INI}$  is zero in DCM status.

When the inductor current reaches peak-current limitation, the internal MOSFET will turn off. The inductor current charges the sampling capacitor (C3) and the output capacitor (C4) via the freewheeling diodes D2 and D3 respectively. In this stage, the sampling capacitor voltage reflects the output voltage.

The output voltage can be regulated by sampling the FB voltage. In the MOSFET OFF time, the inductor current decreases linearly from peak current. When the inductor current falls below the output current, the FB voltage begins to decrease with the sampling capacitor voltage decreasing. Once the FB voltage is detected below the reference voltage of primary MOSFET turn-on threshold, a new switching cycle starts.

The regulated output voltage can be described as the following equation:

$$V_O = V_{FB} \times \left( \frac{R_1 + R_2}{R_2} \right)$$

Figures 3(a) and 3(b) show the operation diagram under DCM and CCM.

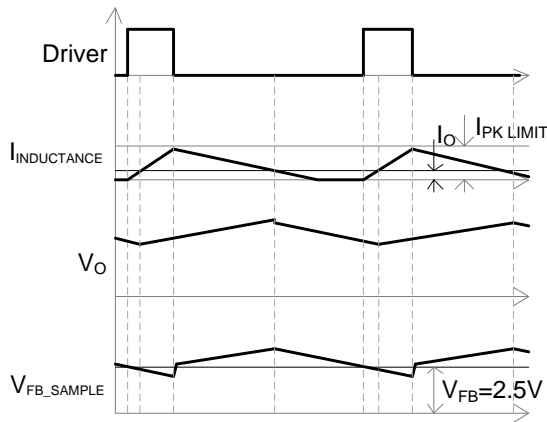

Figure 3(a). DCM

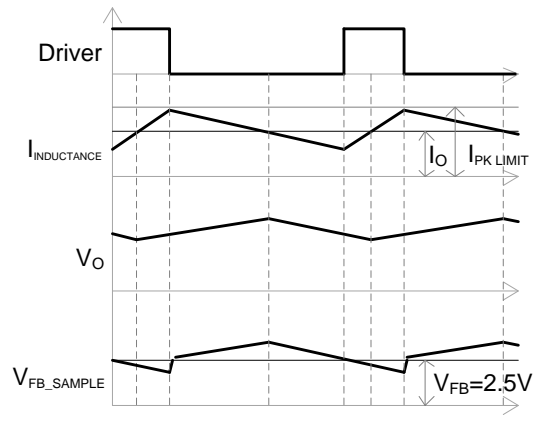

Figure 3(b).CCM

**Startup Control**

A three-stage control method is designed for soft start function. During startup period, the minimum OFF time limit changes from 62μs to 31μs, and then from 31μs to 15.5μs. Every stage has 128 switching cycles (see Figure 4).

NEW PRODUCT

**Performance Characteristics** (continued)

Figure 4 describes the driver time sequence.

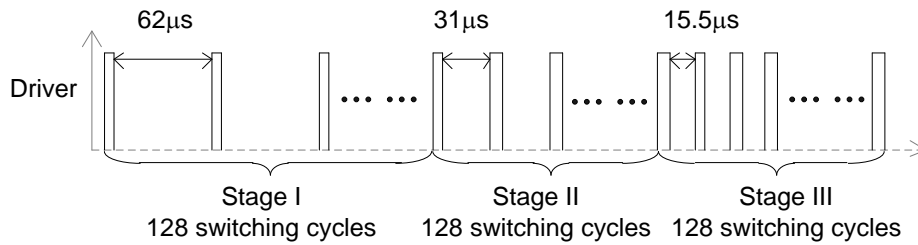

Figure 4. Driver Time Sequence in Startup Process

**Operation Frequency and Peak Current Characteristics**

In order to achieve excellent efficiency performance at light load and improve the overall system efficiency, the peak-current limitation value and switching frequency continuously reduce as the load decreases.

The switching-frequency equation is as follows:

$$f_s = \left(\frac{V_{IN} - V_o}{V_{IN}}\right) \cdot \frac{V_o}{2 \cdot L \cdot (I_{PK} - I_o)}, \text{ for CCM}$$

$$f_s = \left(\frac{V_{IN} - V_o}{V_{IN}}\right) \cdot \frac{2 \cdot V_o \cdot I_o}{L \cdot I_{PK}^2}, \text{ for DCM}$$

The peak-current limitation changes with the different load. When the load decreases, the OFF time increases. At the same time, the peak-current limitation becomes lower with the longer OFF time. The peak-current limitation changes in the following equation:

$$I_{PK} = I_{PK\_MAX} - 4 \text{ mA}/\mu\text{s} \cdot (t_{OFF} - t_{MINOFF})$$

**Overload Protection (OLP)**

With the increase of load, the peak current and the switching frequency increase. When the peak current reaches the maximum limitation, and the OFF time is the minimum OFF time, the output voltage drops if the load continues to increase. Similarly, the FB voltage decreases as the output voltage drops. When FB voltage drops below OLP threshold  $V_{FB\_OLP}$  (1.7V), the internal timer of overload starts to count. Once the overload duration lasts more than the OLP delay time  $t_{OLP}$  (170ms), the OLP occurs.

The time delay setting of OLP should avoid triggering OLP when the system starts up or enters a load transition phase. Therefore it requires that the system startup time must be less than  $t_{OLP}$ . The 170ms time delay of  $t_{OLP}$  is calculated under the condition of 36kHz operating frequency. The different operating frequency corresponds to different time delay, the time delay calculation under different operating frequency ( $f_s$ ) as follows:

$$t_{DELAY} \approx 170ms \times \left(\frac{36kHz}{f_s}\right)$$

**Short-Circuit Protection (SCP)**

The AP3917D shuts down when the peak current exceeds short-circuit threshold, and the AP3917D resumes operation when the fault is removed.

**Over Temperature Protection (OTP)**

The AP3917D integrates an internal over temperature protection function. The AP3917D shuts down when the inner junction temperature exceeds thermal shutdown threshold  $T_{OTP}$  (+150°C). After exceeding the threshold, the BP voltage begins to drop, and when BP voltage drops to  $V_{BP\_RESTART}$  (4.5V), the internal high-voltage regulator turns on to charge the external BP capacitor.

NEW PRODUCT



**Performance Characteristics** (continued)

**Open-Loop Detection**

When the FB voltage drops below open-loop detection threshold voltage  $V_{OLD}$  (60mV), the AP3917D stops working and begins a restart cycle. The open-loop detection is blanked for 64 switching cycles during startup process.

**Overshoot Improvement**

In general, there is no capacitor between FB pin and S pin. But in some cases where strict overshoot is required, we recommend a ceramic capacitor C6 (390pF to 1nF) in Figure 5.

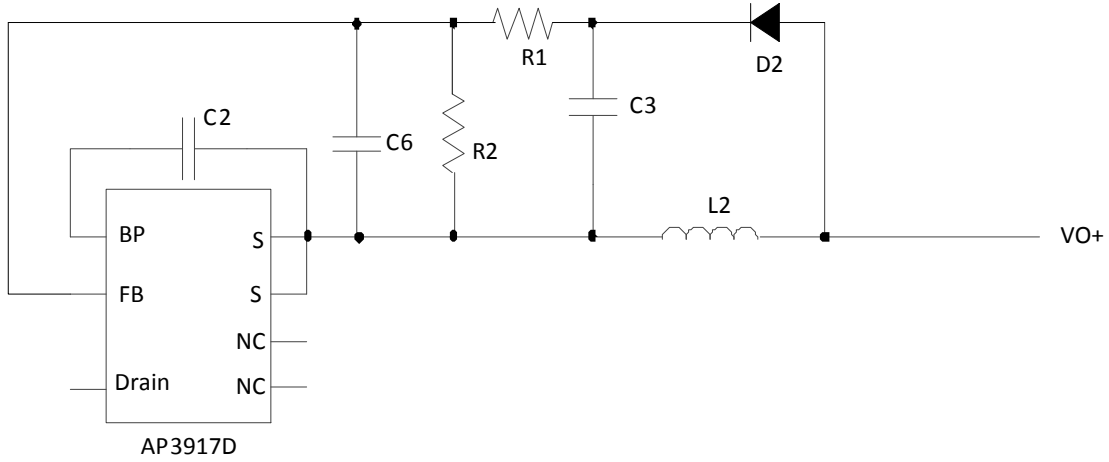

Figure 5. Overshoot Improvement

**Leading-Edge Blanking**

A narrow spike on the leading edge of the current waveform can usually be observed when the power MOSFET is turned on. Normally, the leading-edge blanking time  $t_{LEB1}$  is built in to prevent the false-triggering caused by the turn-on spike. But in the case of short circuit, the leading-edge blanking time is  $t_{LEB2}$ . During this period, the current limit comparator is disabled, and the gate driver cannot be switched off.

NEW PRODUCT

**Ordering Information**

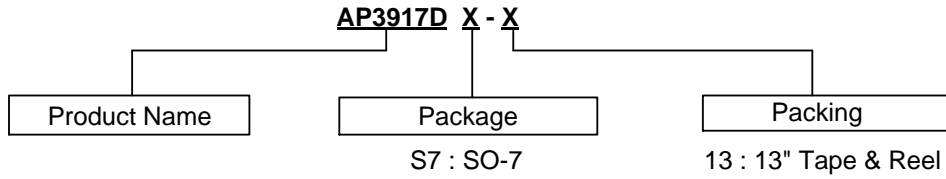

Package	Part Number	Marking ID	13" Tape and Reel	
			Quantity	Part Number Suffix
SO-7	AP3917DS7-13	3917D	4000/Tape and Reel	-13

**Marking Information**

Package Type: SO-7

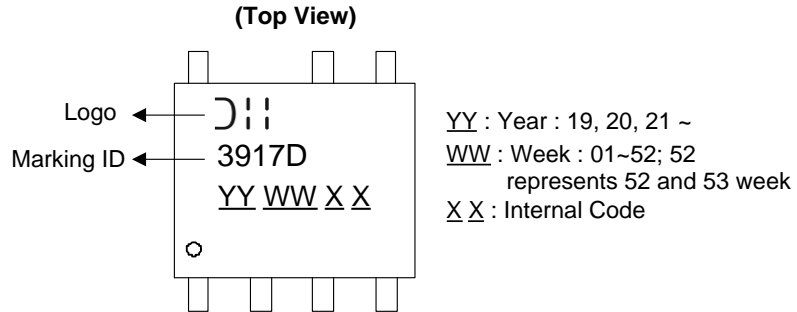

NEW PRODUCT

**Package Outline Dimensions** (All dimensions in mm)

Please see <http://www.diodes.com/package-outlines.html> for the latest version.

**SO-7**

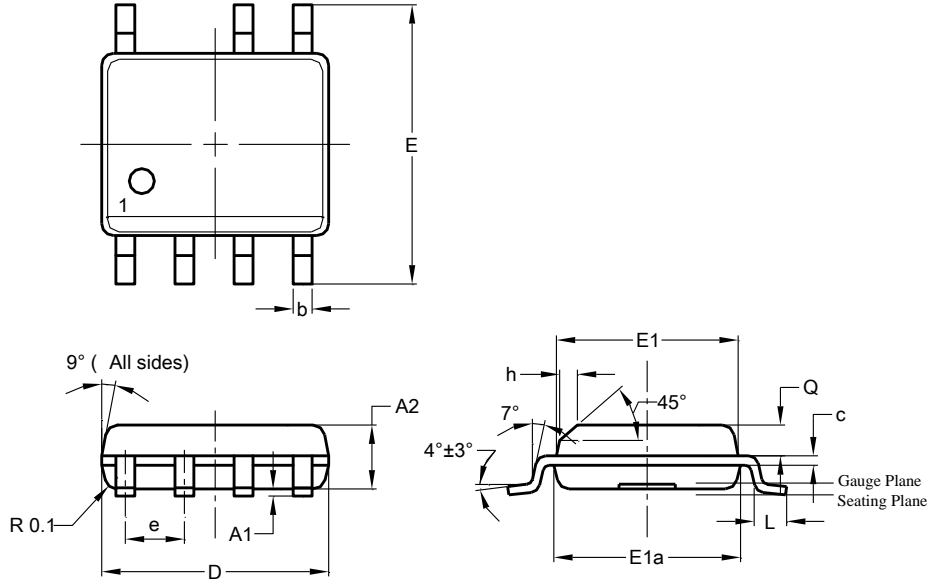

SO-7			
Dim	Min	Max	Typ
A2	1.40	1.50	1.45
A1	0.10	0.20	0.15
b	0.30	0.50	0.40
c	0.15	0.25	0.20
D	4.85	4.95	4.90
E	5.90	6.10	6.00
E1	3.80	3.90	3.85
E1a	3.85	3.95	3.90
e	—	—	1.27
h	—	—	0.35
L	0.62	0.82	0.72
Q	0.60	0.70	0.65
All Dimensions in mm			

**Suggested Pad Layout**

Please see <http://www.diodes.com/package-outlines.html> for the latest version.

**SO-7**

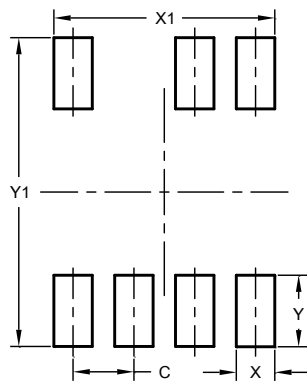

Dimensions	Value (in mm)
C	1.270
X	0.802
X1	4.612
Y	1.505
Y1	6.500

NEW PRODUCT

**IMPORTANT NOTICE**

DIODES INCORPORATED MAKES NO WARRANTY OF ANY KIND, EXPRESS OR IMPLIED, WITH REGARDS TO THIS DOCUMENT, INCLUDING, BUT NOT LIMITED TO, THE IMPLIED WARRANTIES OF MERCHANTABILITY AND FITNESS FOR A PARTICULAR PURPOSE (AND THEIR EQUIVALENTS UNDER THE LAWS OF ANY JURISDICTION).

Diodes Incorporated and its subsidiaries reserve the right to make modifications, enhancements, improvements, corrections or other changes without further notice to this document and any product described herein. Diodes Incorporated does not assume any liability arising out of the application or use of this document or any product described herein; neither does Diodes Incorporated convey any license under its patent or trademark rights, nor the rights of others. Any Customer or user of this document or products described herein in such applications shall assume all risks of such use and will agree to hold Diodes Incorporated and all the companies whose products are represented on Diodes Incorporated website, harmless against all damages.

Diodes Incorporated does not warrant or accept any liability whatsoever in respect of any products purchased through unauthorized sales channel. Should Customers purchase or use Diodes Incorporated products for any unintended or unauthorized application, Customers shall indemnify and hold Diodes Incorporated and its representatives harmless against all claims, damages, expenses, and attorney fees arising out of, directly or indirectly, any claim of personal injury or death associated with such unintended or unauthorized application.

Products described herein may be covered by one or more United States, international or foreign patents pending. Product names and markings noted herein may also be covered by one or more United States, international or foreign trademarks.

This document is written in English but may be translated into multiple languages for reference. Only the English version of this document is the final and determinative format released by Diodes Incorporated.

**LIFE SUPPORT**

Diodes Incorporated products are specifically not authorized for use as critical components in life support devices or systems without the express written approval of the Chief Executive Officer of Diodes Incorporated. As used herein:

A. Life support devices or systems are devices or systems which:

1. are intended to implant into the body, or
2. support or sustain life and whose failure to perform when properly used in accordance with instructions for use provided in the labeling can be reasonably expected to result in significant injury to the user.

B. A critical component is any component in a life support device or system whose failure to perform can be reasonably expected to cause the failure of the life support device or to affect its safety or effectiveness.

Customers represent that they have all necessary expertise in the safety and regulatory ramifications of their life support devices or systems, and acknowledge and agree that they are solely responsible for all legal, regulatory and safety-related requirements concerning their products and any use of Diodes Incorporated products in such safety-critical, life support devices or systems, notwithstanding any devices- or systems-related information or support that may be provided by Diodes Incorporated. Further, Customers must fully indemnify Diodes Incorporated and its representatives against any damages arising out of the use of Diodes Incorporated products in such safety-critical, life support devices or systems.

Copyright © 2019, Diodes Incorporated

[www.diodes.com](http://www.diodes.com)



## Стандарт Электрон Связь

Мы молодая и активно развивающаяся компания в области поставок электронных компонентов. Мы поставляем электронные компоненты отечественного и импортного производства напрямую от производителей и с крупнейших складов мира.

Благодаря сотрудничеству с мировыми поставщиками мы осуществляем комплексные и плановые поставки широчайшего спектра электронных компонентов.

Собственная эффективная логистика и склад в обеспечивает надежную поставку продукции в точно указанные сроки по всей России.

Мы осуществляем техническую поддержку нашим клиентам и предпродажную проверку качества продукции. На все поставляемые продукты мы предоставляем гарантию .

Осуществляем поставки продукции под контролем ВП МО РФ на предприятия военно-промышленного комплекса России , а также работаем в рамках 275 ФЗ с открытием отдельных счетов в уполномоченном банке. Система менеджмента качества компании соответствует требованиям ГОСТ ISO 9001.

Минимальные сроки поставки, гибкие цены, неограниченный ассортимент и индивидуальный подход к клиентам являются основой для выстраивания долгосрочного и эффективного сотрудничества с предприятиями радиоэлектронной промышленности, предприятиями ВПК и научно-исследовательскими институтами России.

С нами вы становитесь еще успешнее!

### Наши контакты:

**Телефон:** +7 812 627 14 35

**Электронная почта:** [sales@st-electron.ru](mailto:sales@st-electron.ru)

**Адрес:** 198099, Санкт-Петербург,  
Промышленная ул, дом № 19, литера Н,  
помещение 100-Н Офис 331