

NB3U23C

1.2 V Dual Channel CMOS Buffer / Translator

Description

The NB3U23C is a 2-input, 2-output buffer/voltage translator for UFS (Universal Flash Storage) in portable consumer applications such as mobile phones, tablets, cameras, etc. This dual channel CMOS buffer accepts 1.8 V CMOS input and translates it to 1.2 V CMOS output. The device is powered using single supply of 1.2 V $\pm 5\%$.

The NB3U23C is packaged in 2 ultra-small 6-pin packages: the 6 pin SC70 and a 6 pin thin UDFN package.

Features

- Operating Frequency: 52 MHz (Max)
- Propagation Delay: 5 ns (Max)
- Low Standby Current: $< 10 \mu\text{A}$ at 1.2 V V_{DD}
- Low Phase Noise Floor: -150 dBc/Hz (Typ)
- Rise/Fall Times ($t_{r/f}$): 2 ns (Max)
- ESD Protection Exceeds JEDEC Standards
 - ◆ 2000 V Human-Body Model (JS-001-2012)
 - ◆ 200 V Machine Model (JESD22-A115C)
 - ◆ 1000 V Charged-Device Model (JESD101E)
- Operating Supply Voltage Range (V_{DD}): 1.2 V $\pm 5\%$
- Operating Temperature Range (Industrial): -40°C to 85°C
- These are Pb-Free Devices



ON Semiconductor®

<http://onsemi.com>

MARKING DIAGRAMS

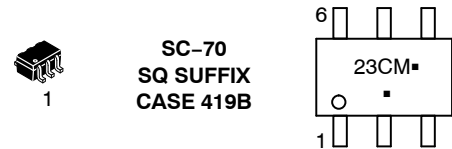

23C = Device Code
M = Date Code*
▪ = Pb-Free Package

(Note: Microdot may be in either location)

*Date Code orientation and/or position may vary depending upon manufacturing location.

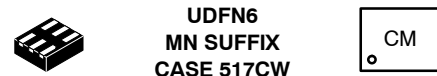

C = Device Code
M = Date Code

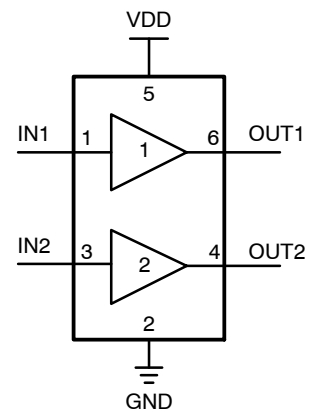

Figure 1. Simplified Logic Diagram

ORDERING INFORMATION

See detailed ordering and shipping information on page 4 of this data sheet.

NB3U23C

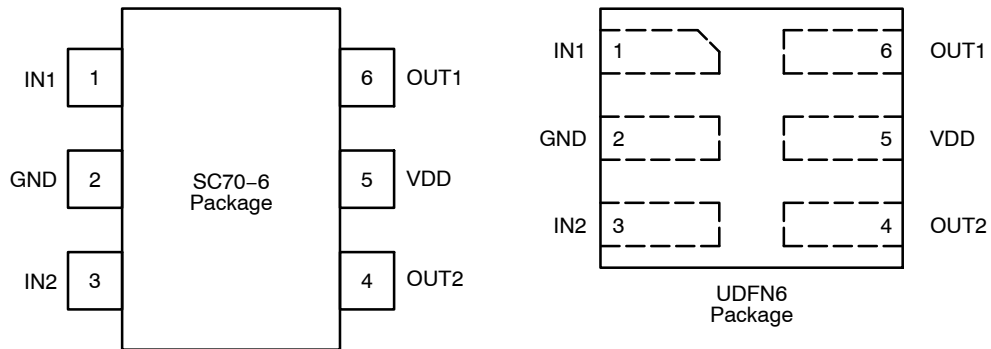

Figure 2. Pinout Diagram (Top Views)

Table 1. PIN DESCRIPTION

Number	Name	Description
1	IN1	Input Clock Signal – Channel 1
2	GND	Power Supply Ground (0 V)
3	IN2	Input Clock Signal – Channel 2
4	OUT2	Output – Channel 2
5	VDD	Power Supply Voltage
6	OUT1	Output – Channel 1

Table 2. ATTRIBUTES

Characteristic	Value
ESD Protection	Human Body Model Machine Model Charge Device Model
Moisture Sensitivity (Note 1)	Level 1
Flammability Rating	Oxygen Index: 28 to 34 UL 94 V-0 @ 0.125 in
Transistor Count	120
Meets or exceeds JEDEC Spec EIA/JESD78 IC Latchup Test II	

1. For additional information, see Application Note AND8003/D.

NB3U23C

Table 3. MAXIMUM RATINGS (Note 2)

Symbol	Parameter	Condition 1	Condition 2	Rating	Unit
V _{DD}	Supply Voltage			3.6	V
V _{in}	Input Voltage			-0.5 ≤ V _I ≤ 2.5	V
I _D	Output Current			25	mA
T _A	Operating Temperature Range, Industrial			-40 to +85	°C
T _{stg}	Storage Temperature Range			-65 to +150	°C
θ _{JA}	Thermal Resistance (Junction-to-Ambient)	0 lfpm 500 lfpm (Note 3)	SC70-6 UDFN-6	210 126 TBD	°C/W
θ _{JC}	Thermal Resistance (Junction-to-Case)	(Note 3)	SC70-6 UDFN-6	100 TBD	°C/W
T _{sol}	Wave Solder			260	°C

Stresses exceeding those listed in the Maximum Ratings table may damage the device. If any of these limits are exceeded, device functionality should not be assumed, damage may occur and reliability may be affected.

- Maximum ratings applied to the device are individual stress limit values (not normal operating conditions) and not valid simultaneously. If stress limits are exceeded device functional operation is not implied, damage may occur and reliability may be affected.
- JEDEC standard multilayer board – 2S2P (2 signal, 2 power).

Table 4. ELECTRICAL CHARACTERISTICS (V_{DD} = 1.2 ±5% V, GND = 0 V, T_A = -40°C to +85°C)

Symbol	Characteristic	Conditions	Min	Typ	Max	Unit
DIDD	Power Supply Current (Single Channel Switching @ 52 MHz)	C _L = 20 pF C _L = 5 pF C _L = 1 pF		2.5 1.5 1		mA
	Power Supply Current (Both Channels Switching @ 52 MHz)	C _L = 20 pF C _L = 5 pF C _L = 1 pF		5 3 2		mA
I _{off}	Standby Current	V _i = V _{IH} Max or GND; V _{DD} = 1.2 V, No Output Load			10	µA
V _{IH}	Input High Voltage		0.65 * V _{DD}		1.98	V
V _{IL}	Input Low Voltage		0		0.35 * V _{DD}	V
V _{OH}	Output High Voltage	C _L = 20 pF R _L = 100 kΩ	0.75 * V _{DD}		V _{DD}	V
V _{OL}	Output Low Voltage	C _L = 20 pF R _L = 100 kΩ	0		0.25 * V _{DD}	V
C _{in}	Input Capacitance				5	pF
F _{clk}	Operating Frequency Range		0		52	MHz
t _{PD}	Propagation Delay	IN _x to OUT _x C _L = 20 pF, R _L = 100 kΩ			5	ns
	Phase Noise Floor Density (Notes 4 and 5)	C _L = 20 pF R _L = 100 kΩ		-150		dBc/Hz
	Additive RMS Phase Jitter (Notes 5 and 6)	C _L = 20 pF R _L = 100 kΩ Offset Frequency Range: 50 kHz to 10 MHz		0.15	0.25	ps
DC	Output Duty Cycle (Note 7)	Input Duty Cycle = 50%, Min Input Slew Rate = 1 V/ns	45		55	%
tr/tf	Output Rise/Fall Times	0.2 * V _{DD} to 0.8 * V _{DD} C _L = 20 pF R _L = 100 kΩ			2	ns

Product parametric performance is indicated in the Electrical Characteristics for the listed test conditions, unless otherwise noted. Product performance may not be indicated by the Electrical Characteristics if operated under different conditions.

- White noise floor.
- This parameter refers to the random jitter only.
- The output RMS phase jitter can be calculated using the following equation:
(Output RMS Phase Jitter)² = (Input RMS Phase Jitter)² + (Additive RMS Phase Jitter)²
- Measured with input voltage swing from 0 V to 1.8 V.

NB3U23C

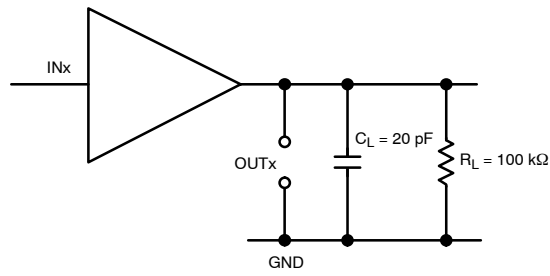

Figure 3. Typical Test Setup for Evaluation

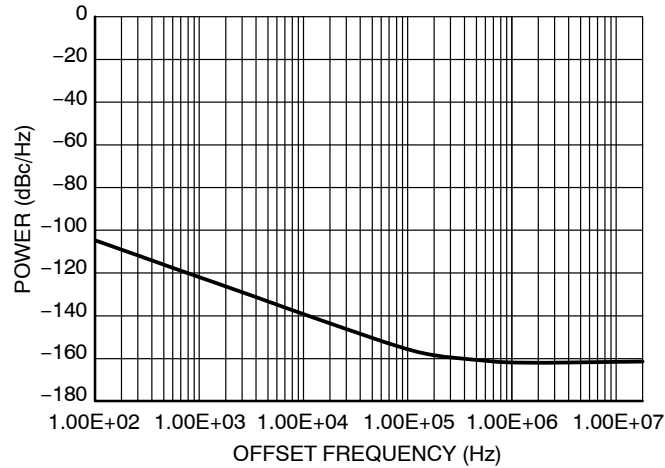

Figure 4. Typical Phase Noise Plot at 50 MHz Carrier Frequency

ORDERING INFORMATION

Device	Package	Shipping [†]
NB3U23CSQTCG	SC-70-6 (Pb-Free)	3000 / Tape & Reel
NB3U23CMNTBG	UDFN6 (Pb-Free)	3000 / Tape & Reel

[†]For information on tape and reel specifications, including part orientation and tape sizes, please refer to our Tape and Reel Packaging Specifications Brochure, BRD8011/D.

NB3U23C

PACKAGE DIMENSIONS

SC-88/SC70-6/SOT-363
CASE 419B-02
ISSUE Y

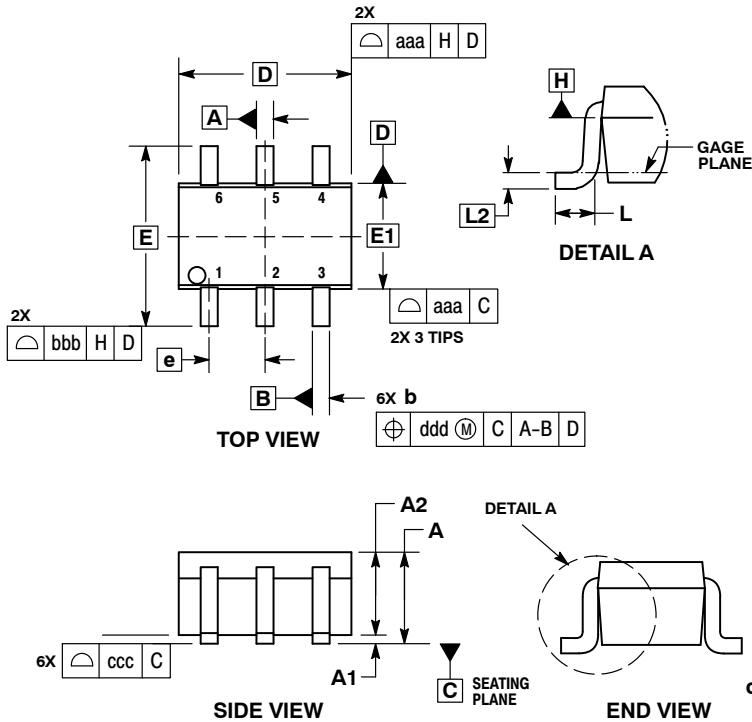

NOTES:

1. DIMENSIONING AND TOLERANCING PER ASME Y14.5M, 1994.
2. CONTROLLING DIMENSION: MILLIMETERS.
3. DIMENSIONS D AND E1 DO NOT INCLUDE MOLD FLASH, PROTRUSIONS, OR GATE BURRS. MOLD FLASH, PROTRUSIONS, OR GATE BURRS SHALL NOT EXCEED 0.20 PER END.
4. DIMENSIONS D AND E1 AT THE OUTERMOST EXTREMES OF THE PLASTIC BODY AND DATUM H.
5. DATUMS A AND B ARE DETERMINED AT DATUM H.
6. DIMENSIONS b AND c APPLY TO THE FLAT SECTION OF THE LEAD BETWEEN 0.08 AND 0.15 FROM THE TIP.
7. DIMENSION b DOES NOT INCLUDE DAMBAR PROTRUSION. ALLOWABLE DAMBAR PROTRUSION SHALL BE 0.08 TOTAL IN EXCESS OF DIMENSION b AT MAXIMUM MATERIAL CONDITION. THE DAMBAR CANNOT BE LOCATED ON THE LOWER RADIUS OF THE FOOT.

DIM	MILLIMETERS			INCHES		
	MIN	NOM	MAX	MIN	NOM	MAX
A	---	---	1.10	---	---	0.043
A1	0.00	---	0.10	0.000	---	0.004
A2	0.70	0.90	1.00	0.027	0.035	0.039
b	0.15	0.20	0.25	0.006	0.008	0.010
C	0.08	0.15	0.22	0.003	0.006	0.009
D	1.80	2.00	2.20	0.070	0.078	0.086
E	2.00	2.10	2.20	0.078	0.082	0.086
E1	1.15	1.25	1.35	0.045	0.049	0.053
e	0.65 BSC			0.026 BSC		
L	0.26	0.36	0.46	0.010	0.014	0.018
L2	0.15 BSC			0.006 BSC		
aaa	0.15			0.006		
bbb	0.30			0.012		
ccc	0.10			0.004		
ddd	0.10			0.004		

RECOMMENDED SOLDERING FOOTPRINT*

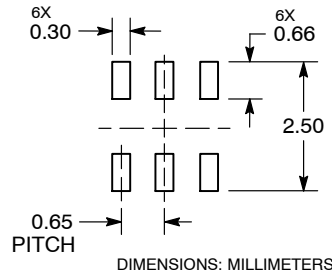

*For additional information on our Pb-Free strategy and soldering details, please download the ON Semiconductor Soldering and Mounting Techniques Reference Manual, SOLDERRM/D.

NB3U23C

PACKAGE DIMENSIONS

UDFN6 1.2x1.4, 0.4P CASE 517CW ISSUE O

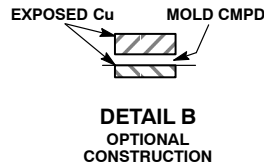
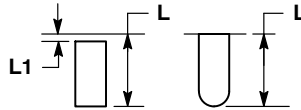
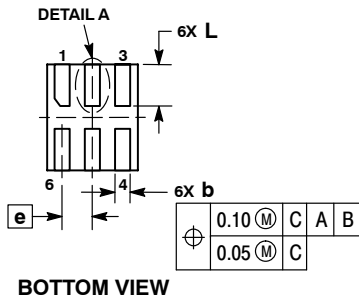
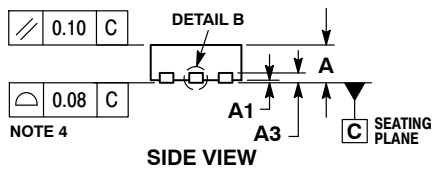
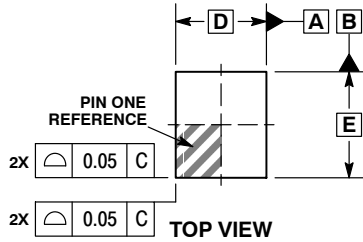

NOTES:

1. DIMENSIONING AND TOLERANCING PER ASME Y14.5M, 1994.
2. CONTROLLING DIMENSION: MILLIMETERS.
3. DIMENSION b APPLIES TO PLATED TERMINAL AND IS MEASURED BETWEEN 0.15 AND 0.25MM FROM THE TERMINAL TIP.

DIM	MILLIMETERS	
	MIN	MAX
A	0.45	0.55
A1	0.00	0.05
A3	0.13 REF	
b	0.15	0.25
D	1.20 BSC	
E	1.40 BSC	
e	0.40 BSC	
L	0.50	0.60
L1	---	0.15

RECOMMENDED SOLDERING FOOTPRINT*

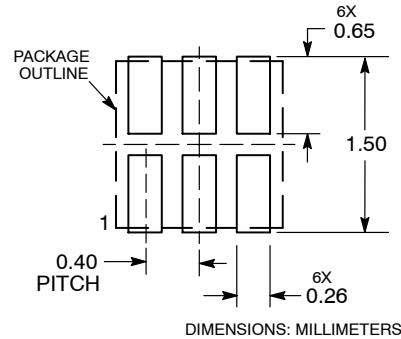

*For additional information on our Pb-Free strategy and soldering details, please download the ON Semiconductor Soldering and Mounting Techniques Reference Manual, SOLDERRM/D.

ON Semiconductor and are registered trademarks of Semiconductor Components Industries, LLC (SCILLC). SCILLC owns the rights to a number of patents, trademarks, copyrights, trade secrets, and other intellectual property. A listing of SCILLC's product/patent coverage may be accessed at www.onsemi.com/site/pdf/Patent-Marking.pdf. SCILLC reserves the right to make changes without further notice to any products herein. SCILLC makes no warranty, representation or guarantee regarding the suitability of its products for any particular purpose, nor does SCILLC assume any liability arising out of the application or use of any product or circuit, and specifically disclaims any and all liability, including without limitation special, consequential or incidental damages. "Typical" parameters which may be provided in SCILLC data sheets and/or specifications can and do vary in different applications and actual performance may vary over time. All operating parameters, including "Typicals" must be validated for each customer application by customer's technical experts. SCILLC does not convey any license under its patent rights nor the rights of others. SCILLC products are not designed, intended, or authorized for use as components in systems intended for surgical implant into the body, or other applications intended to support or sustain life, or for any other application in which the failure of the SCILLC product could create a situation where personal injury or death may occur. Should Buyer purchase or use SCILLC products for any such unintended or unauthorized application, Buyer shall indemnify and hold SCILLC and its officers, employees, subsidiaries, affiliates, and distributors harmless against all claims, costs, damages, and expenses, and reasonable attorney fees arising out of, directly or indirectly, any claim of personal injury or death associated with such unintended or unauthorized use, even if such claim alleges that SCILLC was negligent regarding the design or manufacture of the part. SCILLC is an Equal Opportunity/Affirmative Action Employer. This literature is subject to all applicable copyright laws and is not for resale in any manner.

PUBLICATION ORDERING INFORMATION

LITERATURE FULFILLMENT:
Literature Distribution Center for ON Semiconductor
P.O. Box 5163, Denver, Colorado 80217 USA
Phone: 303-675-2175 or 800-344-3860 Toll Free USA/Canada
Fax: 303-675-2176 or 800-344-3867 Toll Free USA/Canada
Email: orderlit@onsemi.com

N. American Technical Support: 800-282-9855 Toll Free
USA/Canada
Europe, Middle East and Africa Technical Support:
Phone: 421 33 790 2910
Japan Customer Focus Center
Phone: 81-3-5817-1050

ON Semiconductor Website: www.onsemi.com
Order Literature: <http://www.onsemi.com/orderlit>
For additional information, please contact your local Sales Representative



Стандарт Электрон Связь

Мы молодая и активно развивающаяся компания в области поставок электронных компонентов. Мы поставляем электронные компоненты отечественного и импортного производства напрямую от производителей и с крупнейших складов мира.

Благодаря сотрудничеству с мировыми поставщиками мы осуществляем комплексные и плановые поставки широчайшего спектра электронных компонентов.

Собственная эффективная логистика и склад в обеспечивает надежную поставку продукции в точно указанные сроки по всей России.

Мы осуществляем техническую поддержку нашим клиентам и предпродажную проверку качества продукции. На все поставляемые продукты мы предоставляем гарантию .

Осуществляем поставки продукции под контролем ВП МО РФ на предприятия военно-промышленного комплекса России , а также работаем в рамках 275 ФЗ с открытием отдельных счетов в уполномоченном банке. Система менеджмента качества компании соответствует требованиям ГОСТ ISO 9001.

Минимальные сроки поставки, гибкие цены, неограниченный ассортимент и индивидуальный подход к клиентам являются основой для выстраивания долгосрочного и эффективного сотрудничества с предприятиями радиоэлектронной промышленности, предприятиями ВПК и научно-исследовательскими институтами России.

С нами вы становитесь еще успешнее!

Наши контакты:

Телефон: +7 812 627 14 35

Электронная почта: sales@st-electron.ru

Адрес: 198099, Санкт-Петербург,
Промышленная ул, дом № 19, литера Н,
помещение 100-Н Офис 331