



EVALUATION BOARD FOR Si5013 SiPHY™ MULTI-RATE SONET/SDH CLOCK AND DATA RECOVERY IC

Description

The Si5013 evaluation board provides a platform for testing and characterizing Silicon Laboratories' Si5013 SiPHY™ multi-rate SONET/SDH clock and data recovery IC. The Si5013 CDR supports OC-12/3, STM 4/1 data rates.

All high-speed I/Os are ac coupled to ease interfacing to industry standard test equipment.

Features

- Single 3.3 V power supply
- Differential I/Os ac coupled
- Simple jumper configuration

Function Block Diagram

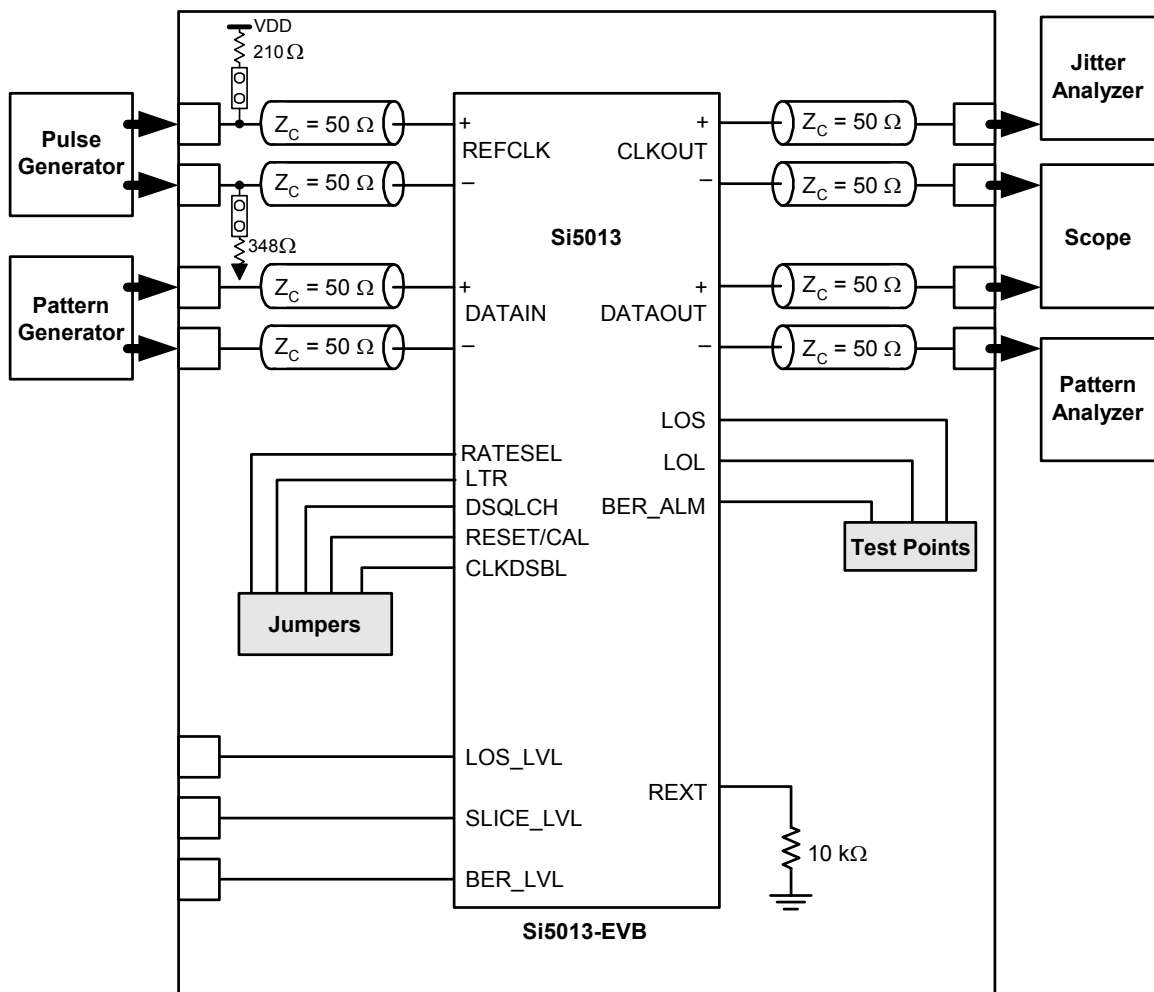

Functional Description

The evaluation board simplifies characterization of the Si5013 Clock and Data Recovery (CDR) device by providing access to all of the Si5013 I/Os. Device performance can be evaluated by following the “Test Configuration” section. Specific performance metrics include input sensitivity, jitter tolerance, jitter generation, and jitter transfer.

Power Supply

The evaluation board requires one 3.3 V supply. Supply filtering is placed on the board to filter typical system noise components; however, initial performance testing should use a linear supply capable of supplying the nominal voltage $\pm 5\%$ dc.

CAUTION: The evaluation board is designed so that the body of the SMA jacks and GND are shorted. Care must be taken when powering the PCB at potentials other than GND at 0.0 V and VDD at 3.3 V relative to chassis GND.

Device Powerdown

The CDR can be powered down via the RESET/CAL signal. When asserted, the evaluation board draws minimal current. RESET/CAL is controlled via one jumper located in the lower left-hand corner of the evaluation board. RESET/CAL is wired to the signal post adjacent to the VDD post. For a valid reset to occur when using external reference clock mode, a proper external reference clock frequency must be applied as specified in Table 1. CLKOUT, DATAOUT, DATAIN, CLKOUT, DATAOUT, and DATAIN (all high-speed I/Os) are wired to the board perimeter on 30 mil (0.030 inch) 50 Ω microstrip lines to the end-launch SMA jacks as labeled on the PCB. These I/Os are ac coupled to simplify direct connection to a wide array of standard test hardware. Because each of these signals are differential, both the positive (+) and negative (–) terminals must be terminated to 50 Ω . Terminating only one side will adversely degrade the performance of the CDR. The inputs are terminated on the die with 50 Ω resistors.

Note: The 50 Ω termination is for each terminal/side of a differential signal, thus the differential termination is actually 50 Ω + 50 Ω = 100 Ω .

REFCLK

REFCLK is optional for clock and data recovery within the Si5013 device. If REFCLK is not used, jumper both JP15 and JP16. These jumpers pull the REFCLK+ input to VDD and REFCLK– input to GND, which configures the device to operate without an external reference.

When applied, REFCLK is used to center the frequency of the DSPLL™ so the device can lock to the data. Ideally, the REFCLK frequency should be 1/128th, 1/32nd, or 1/16th the VCO frequency and must have a frequency accuracy of ± 100 ppm. Internally, the CDR automatically recognizes the REFCLK frequency within one of these three frequency ranges. Typical REFCLK frequencies are given in Table 1. REFCLK is ac coupled to the SMA jacks located on the top side of the evaluation board.

Table 1. Typical REFCLK Frequencies

SONET/SDH	Gigabit Ethernet	SONET/SDH with 15/14 FEC	Ratio of VCO to REFCLK
19.44 MHz	19.53 MHz	20.83 MHz	128
77.76 MHz	78.125 MHz	83.31 MHz	32
155.52 MHz	156.25 MHz	166.63 MHz	16

RATESEL

RATESEL is used to configure the CDR to recover clock and data at different data rates. RATESEL is an input controlled via a jumper (JP10) located in the lower left-hand corner of the evaluation board. RATESEL is wired to the center post (signal post) between VDD and GND. For example, the OC-12 data rate is selected by jumping RATESEL to a 1 (VDD).

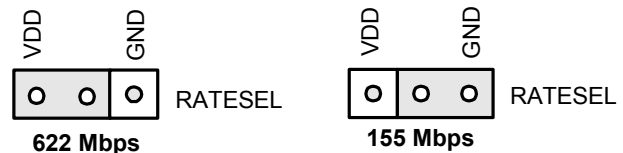

Figure 1. RATESEL Jumper Configurations

Loss-of-Lock (LOL)

Loss-of-lock ($\overline{\text{LOL}}$) is an indicator of the relative frequency between the data and the REFCLK. $\overline{\text{LOL}}$ asserts when the frequency difference is greater than ± 600 ppm. To prevent $\overline{\text{LOL}}$ from de-asserting prematurely, there is hysteresis in returning from the out-of-lock condition. $\overline{\text{LOL}}$ will be de-asserted when the frequency difference is less than ± 300 ppm.

$\overline{\text{LOL}}$ is wired to a test point which is located on the upper right-hand side of the evaluation board.

Loss-of-signal Alarm Threshold Control

The loss-of-signal alarm ($\overline{\text{LOS}}$) is used to signal low incoming data amplitude levels. The programmable threshold control is set by applying a dc voltage level from a low-noise voltage source to the LOS_LVL pin. The LOS_LVL is controllable through the BNC jack J10. The mapping of the LOS_LVL voltage to input signal alarm threshold level is shown in Figure 2. The LOS Threshold to LOS Level is mapped as follows:

$$V_{\text{LOS}} = \frac{V_{\text{LOS_LVL}} - 1.5}{25}$$

If this function is not used, install jumper to JP1 header

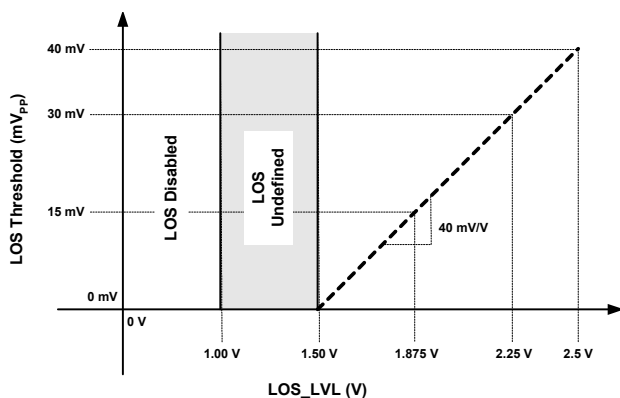

Figure 2. LOS_LVL Mapping

Extended LOS Hysteresis Option

An optional LOS Hysteresis Extension circuit is included on the Si5013-EVB to provide a convenient means of increasing the amount of LOS Alarm hysteresis when testing and evaluating the Si5013 LOS functionality. This simple network will extend the LOS hysteresis to approximately 6 dB, thereby preventing unnecessary switching on LOS for low-level DATAIN signals in the range of 20 mV_{PPD}. Hysteresis is defined as the ratio of the LOS deassert level (LOSD) and the LOS assert level (LOSA). The hysteresis in decibels is calculated as $20\log(\text{LOSD}/\text{LOSA})$. This circuit is constructed with one CMOS inverter (U2) and two resistors (R12, R13) mounted on the underside of the PCB. If desired, this circuit can be enabled by installing a jumper on JP17 (HYST ENABLE) located near the power entry block.

Data Slicing Level

The slicing level allows optimization of the input cross-over point for systems where the slicing level is not at the amplitude average. The data slicing level can be adjusted from the nominal cross-over point of the data by applying a voltage to the SLICE_LVL pin.

SLICE_LVL is controllable through the BNC jack J11. The SLICE_LVL to the data slicing level is mapped as follows:

$$V_{\text{SLICE}} = \frac{V_{\text{SLICE_LVL}} - 1.5}{50}$$

If this function is not used, install jumper to JP6 header.

Bit-Error-Rate Alarm Threshold

The bit-error-rate of the incoming data can be monitored by the BER_ALM pin. When the bit-error-rate exceeds an externally set threshold level, BER_ALM is asserted. BER_ALM is brought to a test point located in the upper right-hand corner of the board. The BER_ALM threshold level is set by applying a dc voltage to the BER_LVL pin. BER_LVL is controllable through the BNC jack J12. Jumper JP7 to disable the BER alarm. Refer to the "BER Detection" section of the Si5012/Si5013 data sheet for threshold level programming.

Test Configuration

The three critical jitter tests typically performed on a CDR device are jitter transfer, jitter tolerance, and jitter generation. By connecting the Si5013 Evaluation Board as shown in Figure 3, all three measurements can be easily made.

When applied, REFCLK should be within ± 100 ppm of the frequency selected from Table 1 and RESET/CAL must be unjumpered.

Jitter Tolerance: Referring to Figure 3, this test requires a pattern generator, a clock source (synthesizer signal source), a modulation source, a jitter analyzer, a pattern analyzer, and a pulse generator (all unconnected high-speed outputs must be terminated to 50 Ω). During this test, the Jitter Analyzer directs the Modulation Source to apply prescribed amounts of jitter to the synthesizer source. This "jitters" the pattern generator timebase which drives the DATAIN ports of the CDR. The Bit-Error-Rate (BER) is monitored on the Pattern Analyzer. The modulation (jitter) frequency and amplitude is recorded when the BER approaches a specified threshold. The Si5013 limiting amplifier can also be examined during this test. Simply lower the amplitude of the incoming data to the minimum value typically expected at the limiting amplifier inputs (typically 10 mV_{PP} for the Si5013 device).

Jitter Generation: Referring to Figure 3, this test requires a pattern generator, a clock source (synthesizer signal source), a jitter analyzer, and a pulse generator (all unconnected high-speed outputs must be terminated to 50 Ω). During this test, there is no modulation of the Data Clock, so the data that is sent to the CDR is jitter free. The Jitter Analyzer measures the

Si5013-EVB

RMS and peak-to-peak jitter on the CDR CLKOUT. Thus, any jitter measured is jitter generated by the CDR.

Jitter Transfer: Referring to Figure 3, this test requires a pattern generator, a clock source (synthesizer signal source), a modulation source, a jitter analyzer, and a pulse generator (all unconnected high-speed outputs

must be terminated to 50 Ω). During this test, the Jitter Analyzer modulates the data pattern and data clock reference. The modulated data clock reference is compared with the CLKOUT of the CDR. Jitter on CLKOUT relative to the jitter on the data clock reference is plotted versus modulation frequency at predefined jitter amplitudes.

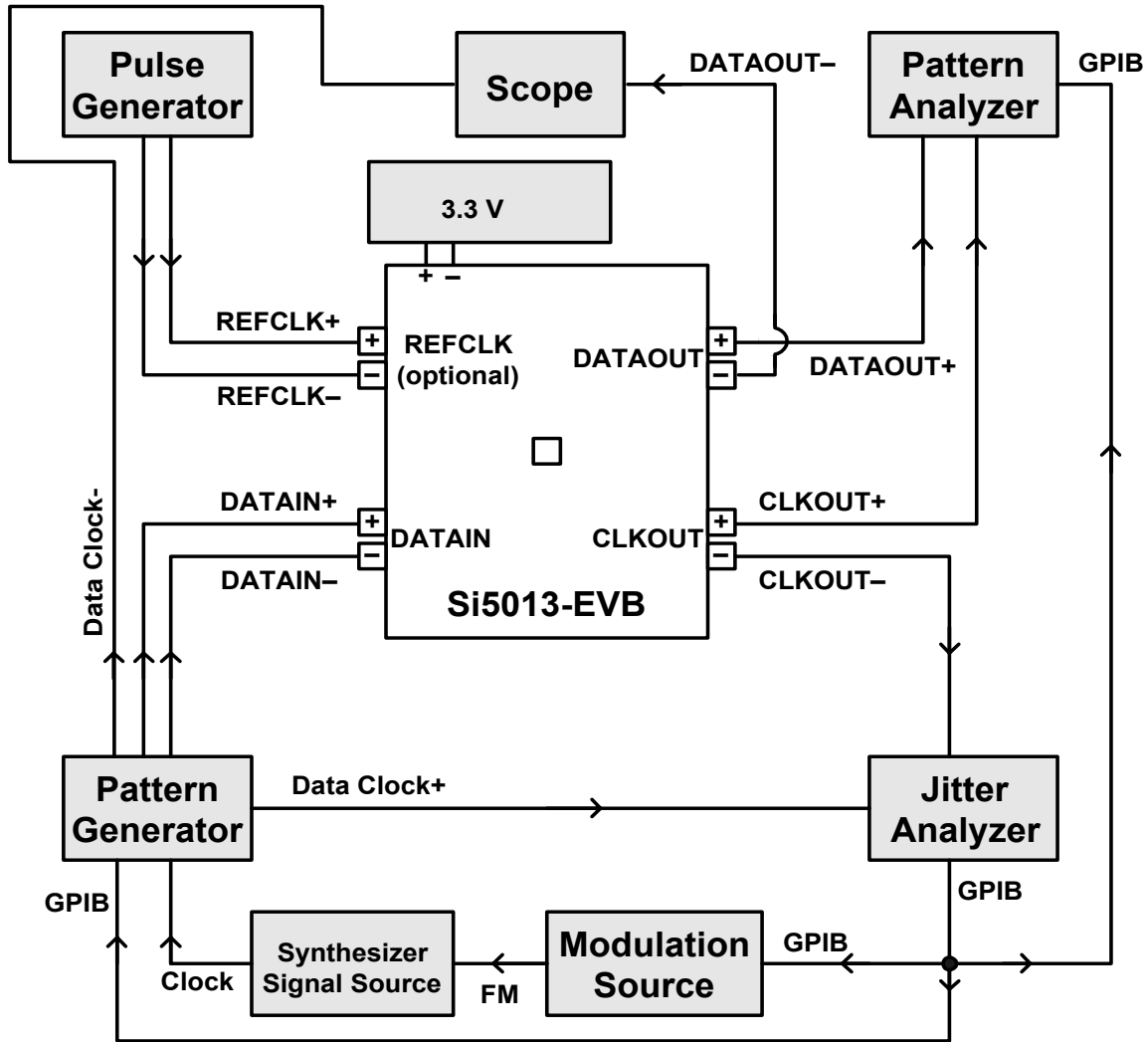

Figure 3. Test Configuration for Jitter Tolerance, Transfer, and Generation

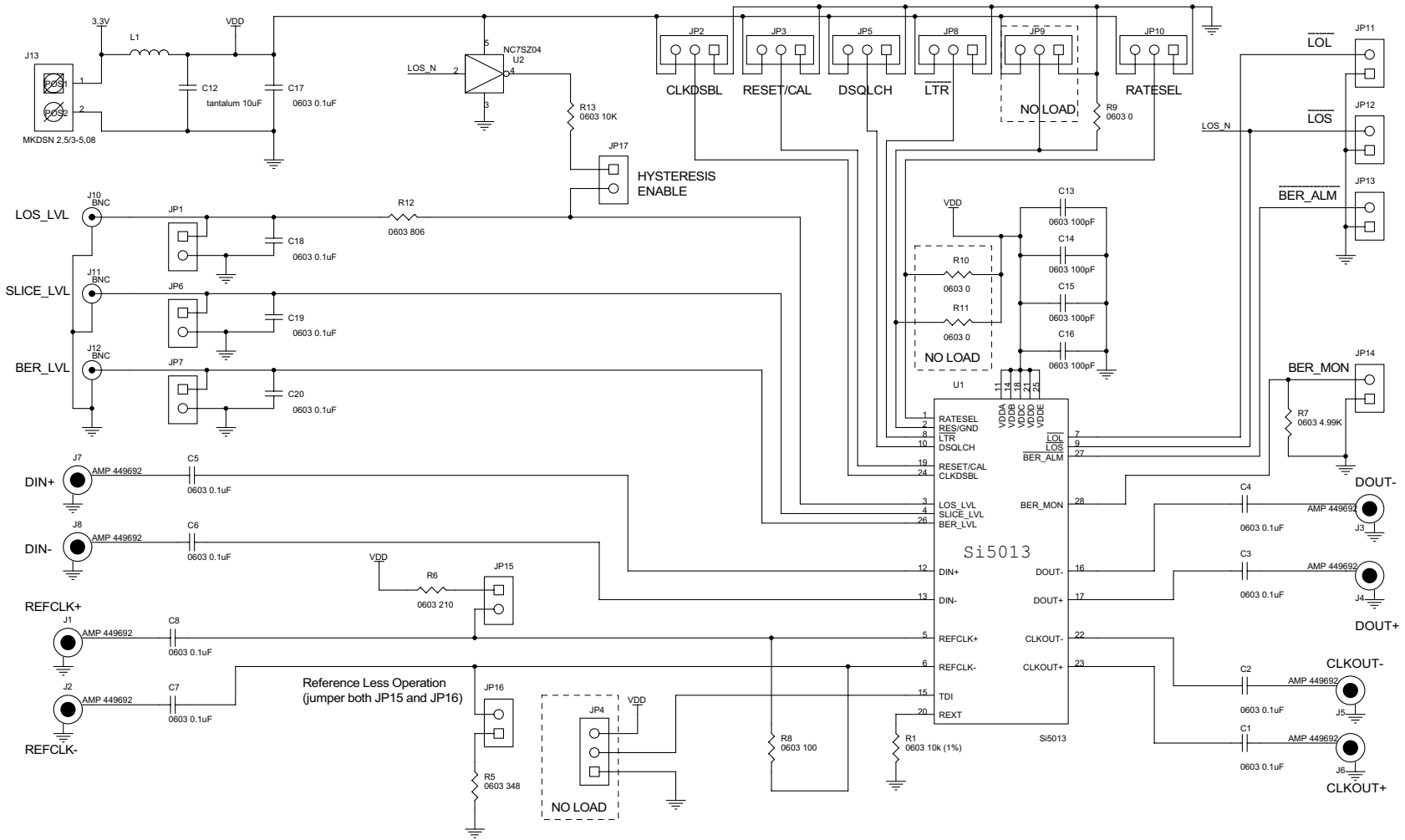

Figure 4. Si5013 Schematic

Si5013-EVB

Bill of Materials

Si5013EVB Assy Rev B-01 BOM			3/29/2002
Reference	Description	Manufacturer's #	Manufacturer
C1,C2,C3,C4,C5,C6, C7,C8,C17,C18,C19, C20	CAP,SM,0.1UF,16V,20%,X7R,0603	C0603X7R160-104KNE	VENKEL
C12	CAP,SM,10UF,10V,10%,TANTALUM,3216	TA010TCM106KAR	VENKEL
C13,C14,C15,C16	CAP,SM,100PF,50V,10%,C0G,0603	C0603C0G500-101KNE	VENKEL
JP1,JP6,JP7,JP11, JP12,JP13,JP14, JP15,JP16,JP17	CONN,HEADER,2X1	2340-6111TN or 2380-6121TN	3M
JP2,JP3,JP5,JP8, JP10	CONN,HEADER,3X1	2340-6111TN or 2380-6121TN	3M
J1,J2,J3,J4,J5,J6, J7,J8	CONN,SMA SIDE MOUNT	901-10003	AMPHENOL
J10,J11,J12	CONN,BNC,VERT	161-9317	MOUSER
J13	CONN,POWER,2 POSITION	1729018	PHOENIX CONTACT
L1	FERRITE,SM,600,1206	BLM31A601S	MURATA
R1,R13	RES,SM,10K,1%,0603	CR0603-16W-1002FT	VENKEL
R5	RES,SM,348,1%,0603	CR0603-16W-3480FT	VENKEL
R6	RES,SM,210,1%,0603	CR0603-16W-2100FT	VENKEL
R7	RES,SM,4.99K,1%,0603	CR0603-16W-4991FT	VENKEL
R8	RES,SM,100,1%,0603	CR0603-16W-1000FT	VENKEL
R9	RES,SM,0 OHM,0603	CR0603-16W-000T	VENKEL
R12	RES,SM,806,1%,0603	CR0603-16W-8060FT	VENKEL
U1	Si5013 Rev B Device	Si5013-BM Rev B	SILICON LABORATORIES
U2	IC,SM,7SZ04, SINGLE GATE INVERTER,5 PIN SOT23	NC7SZ04M5X	FAIRCHILD
PCB	Printed Circuit Board	Si5013-EVB PCB Rev C	SILICON LABORATORIES
No Load			
JP4,JP9	CONN,HEADER,3X1	2340-6111TN or 2380-6121TN	3M
R10,R11	RES,SM,0 OHM,0603	CR0603-16W-000T	VENKEL

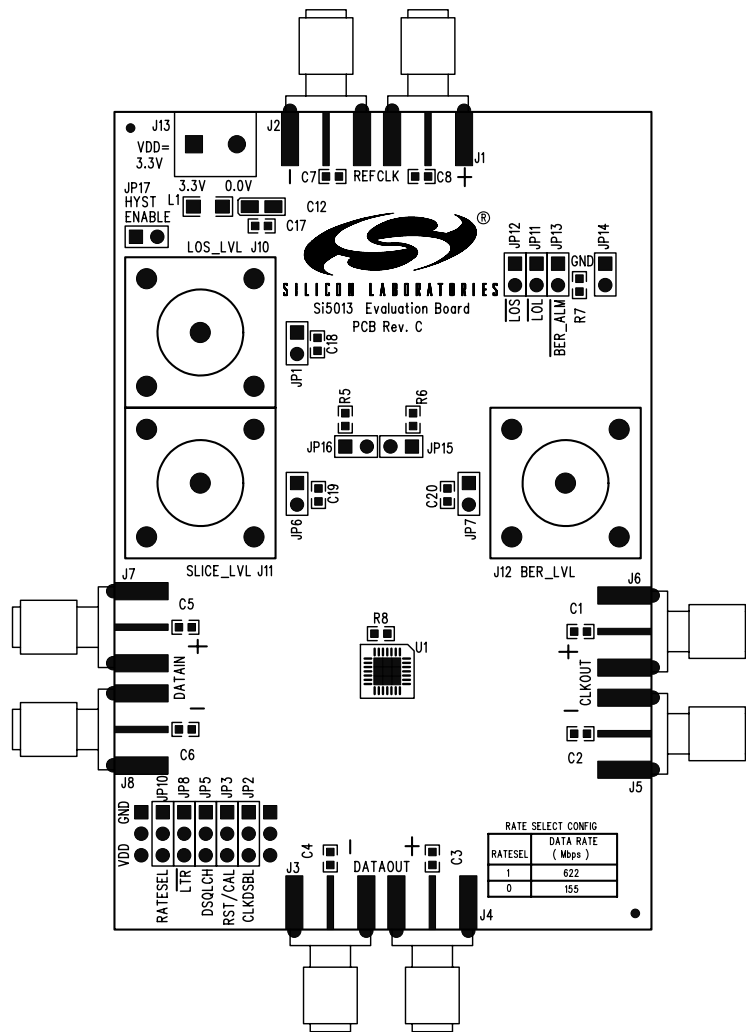

Figure 5. Si5013 Top View

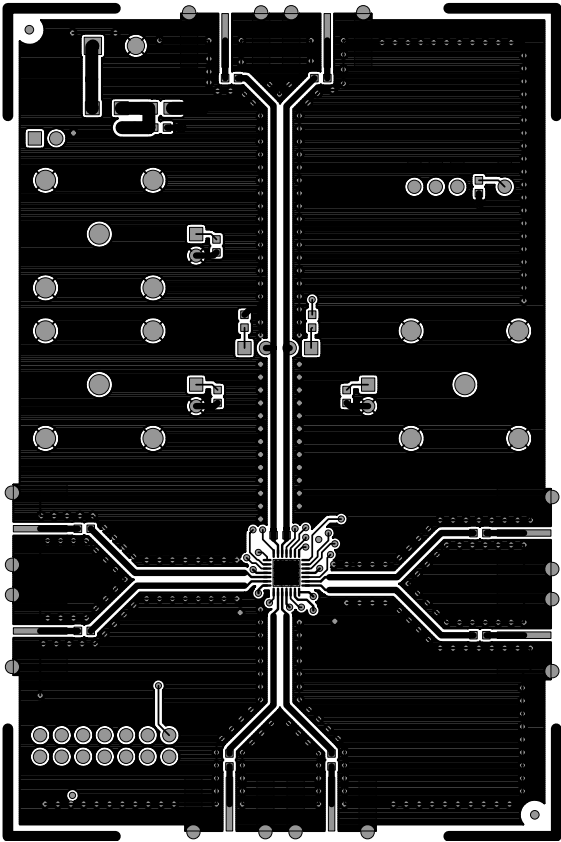

Figure 6. Si5013 Component Side

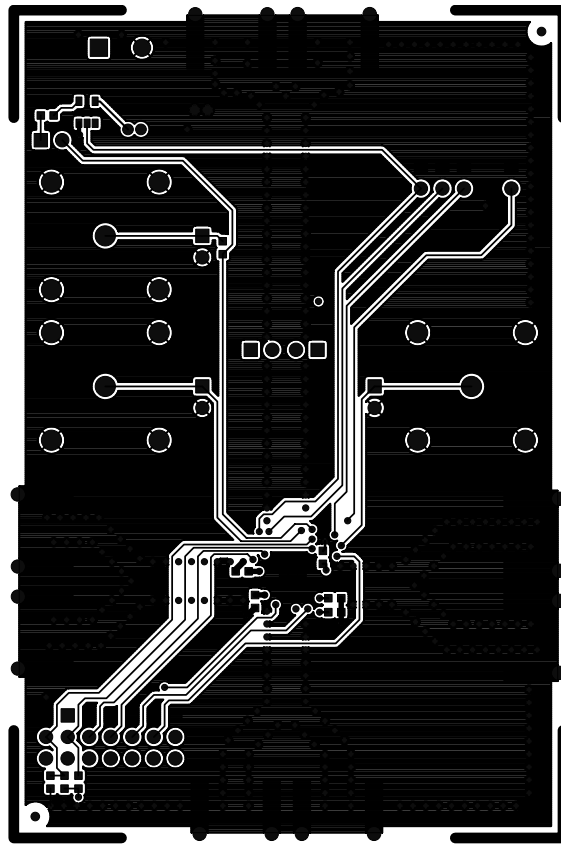

Figure 7. Si5013 Solder Side

Si5013-EVB

Document Change List

Revision 0.22 to Revision 1.0

- “Preliminary” language removed.

Evaluation Board Assembly Revision History

Assembly Level	PCB Rev.	Si5013 Rev.	Assembly Notes
B-01	Rev. C	Rev. B	Assemble per BOM rev B-01

Notes:

Si5013-EVB

Contact Information

Silicon Laboratories Inc.
4635 Boston Lane
Austin, TX 78735
Tel: 1+(512) 416-8500
Fax: 1+(512) 416-9669
Toll Free: 1+(877) 444-3032
Email: productinfo@silabs.com
Internet: www.silabs.com

The information in this document is believed to be accurate in all respects at the time of publication but is subject to change without notice. Silicon Laboratories assumes no responsibility for errors and omissions, and disclaims responsibility for any consequences resulting from the use of information included herein. Additionally, Silicon Laboratories assumes no responsibility for the functioning of undescribed features or parameters. Silicon Laboratories reserves the right to make changes without further notice. Silicon Laboratories makes no warranty, representation or guarantee regarding the suitability of its products for any particular purpose, nor does Silicon Laboratories assume any liability arising out of the application or use of any product or circuit, and specifically disclaims any and all liability, including without limitation consequential or incidental damages. Silicon Laboratories products are not designed, intended, or authorized for use in applications intended to support or sustain life, or for any other application in which the failure of the Silicon Laboratories product could create a situation where personal injury or death may occur. Should Buyer purchase or use Silicon Laboratories products for any such unintended or unauthorized application, Buyer shall indemnify and hold Silicon Laboratories harmless against all claims and damages.

Silicon Laboratories, Silicon Labs, and SiPHY are trademarks of Silicon Laboratories Inc.

Other products or brandnames mentioned herein are trademarks or registered trademarks of their respective holders.



Стандарт Электрон Связь

Мы молодая и активно развивающаяся компания в области поставок электронных компонентов. Мы поставляем электронные компоненты отечественного и импортного производства напрямую от производителей и с крупнейших складов мира.

Благодаря сотрудничеству с мировыми поставщиками мы осуществляем комплексные и плановые поставки широчайшего спектра электронных компонентов.

Собственная эффективная логистика и склад в обеспечивает надежную поставку продукции в точно указанные сроки по всей России.

Мы осуществляем техническую поддержку нашим клиентам и предпродажную проверку качества продукции. На все поставляемые продукты мы предоставляем гарантию .

Осуществляем поставки продукции под контролем ВП МО РФ на предприятия военно-промышленного комплекса России , а также работаем в рамках 275 ФЗ с открытием отдельных счетов в уполномоченном банке. Система менеджмента качества компании соответствует требованиям ГОСТ ISO 9001.

Минимальные сроки поставки, гибкие цены, неограниченный ассортимент и индивидуальный подход к клиентам являются основой для выстраивания долгосрочного и эффективного сотрудничества с предприятиями радиоэлектронной промышленности, предприятиями ВПК и научно-исследовательскими институтами России.

С нами вы становитесь еще успешнее!

Наши контакты:

Телефон: +7 812 627 14 35

Электронная почта: sales@st-electron.ru

Адрес: 198099, Санкт-Петербург,
Промышленная ул, дом № 19, литера Н,
помещение 100-Н Офис 331