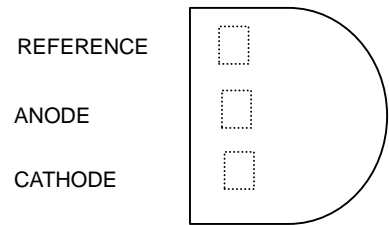




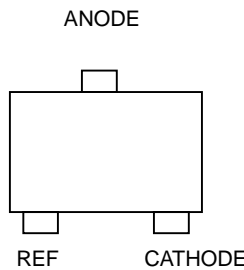
The TL431 integrated circuits are three-terminal programmable shunt regulator diodes. These monolithic IC voltage references operate as a low temperature coefficient zener which is programmable from Vref to 36 volts with two external resistors. This device exhibits a wide operating current range of 1.0 to 100 mA with a typical dynamic impedance of 0.22Ω. The characteristics of these references make them excellent replacements for zener diodes in many applications such as digital voltmeters, power supplies, and op amp circuitry. The 2.5 volt reference makes it convenient to obtain a stable reference from 5.0 volt logic supplies, and since the TL431 operates as a shunt regulator, it can be used as either a positive or negative voltage reference

## FEATURE

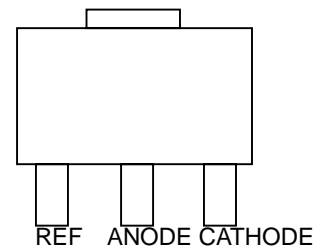
1. Programmable Output Voltage to 36 Volts
2. Low Dynamic Output Impedance, 0.22Ω Typical
3. Sink Current Capability of 1.0 to 100mA
4. Equivalent Full-Range Temperature Coefficient of 50ppm/°C Typical
5. Temperature Compensated for Operation over Full Rated Operating Temperature Range
6. Low Output Noise Voltage



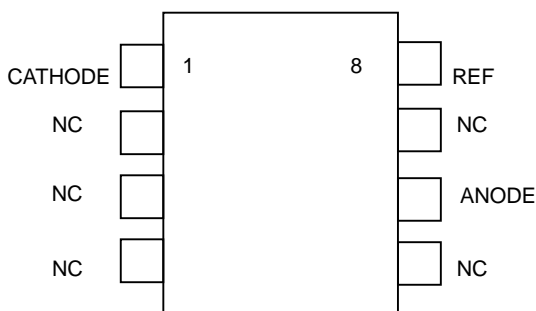
**TO-92 TOP VIEW**



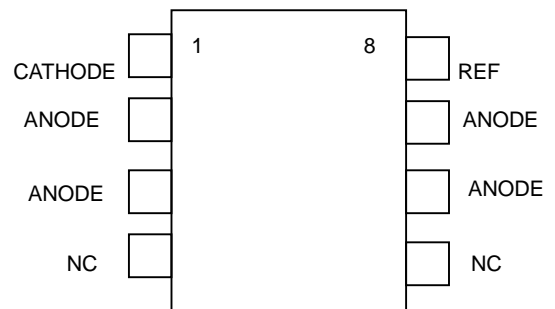
**SOT-23 TOP VIEW**



**SOT-89 TOP VIEW**



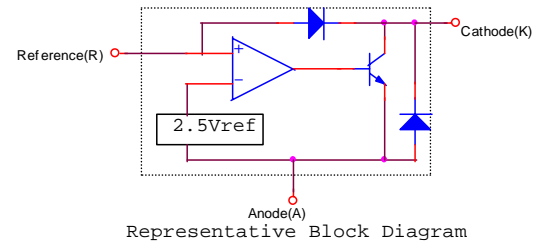
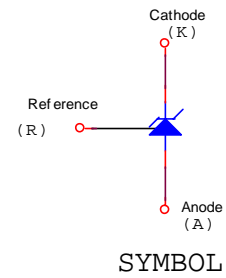
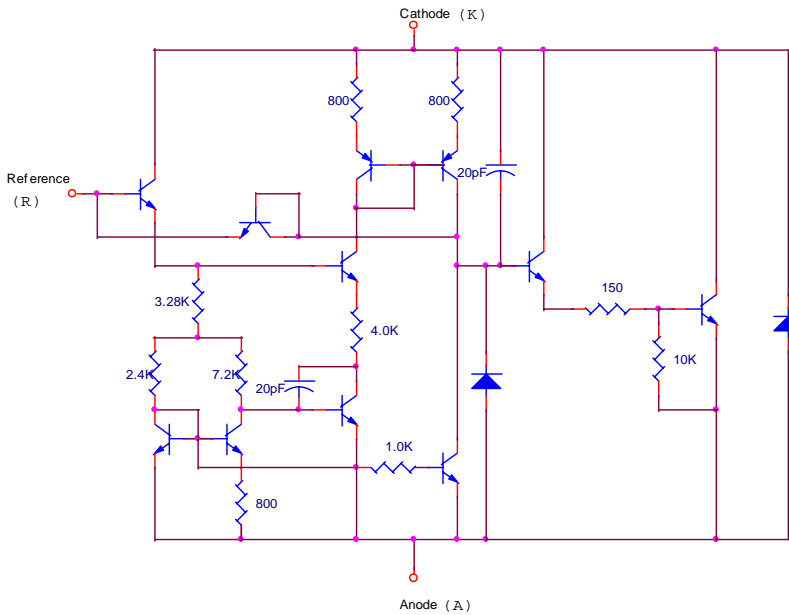
**DIP-8 TOP VIEW**



**SOP-8 TOP VIEW**



## ● BLOCK DIAGRAM



## ● ABSOLUTE MAXIMUM RATINGS

(Full operating ambient temperature range applies, unless otherwise noted)

| Rating                                                                                    | Symbol    | Value        | Unit |
|-------------------------------------------------------------------------------------------|-----------|--------------|------|
| Cathode To Anode Voltage                                                                  | $V_{KA}$  | 37           | V    |
| Cathode Current Range, Continuous                                                         | $I_K$     | -100 to +150 | mA   |
| Reference Input Current Range, Continuous                                                 | $I_{ref}$ | -0.05 to +10 | mA   |
| Operating Junction Temperature                                                            | $T_J$     | 150          | °C   |
| Operating Ambient Temperature Range<br>TL431CT/CP/CD/CH/CLT1                              | $T_A$     | -20 ~ +85    | °C   |
| Storage temperature Range                                                                 | $T_{stg}$ | -65 to +150  | °C   |
| Total Power Dissipation @ $T_A=25^\circ\text{C}$<br>Derate above 25°C Ambient Temperature | $P_D$     | 0.70         | W    |
| T,D Suffix Package                                                                        |           |              |      |
| P Suffix Package                                                                          |           |              |      |
| H Suffix Package                                                                          |           |              |      |
| LT1 Suffix Package                                                                        |           |              |      |



|                                                                                                                                                                                          |       |            |   |
|------------------------------------------------------------------------------------------------------------------------------------------------------------------------------------------|-------|------------|---|
| Total Power Dissipation @ $T_C=25^\circ\text{C}$<br>Derate above $25^\circ\text{C}$ Case Temperature<br>T,D Suffix Package<br>P Suffix Package<br>H Suffix Package<br>LT1 Suffix Package | $P_D$ | 1.5<br>3.0 | W |
|------------------------------------------------------------------------------------------------------------------------------------------------------------------------------------------|-------|------------|---|

● **THERMAL CHARACTERISTICS**

| Characteristics                         | Symbol          | T,D Suffix | P Suffix | H Suffix | LT1 Suffix | Unit               |
|-----------------------------------------|-----------------|------------|----------|----------|------------|--------------------|
| Thermal Resistance, Junction to Ambient | $R_{\theta JA}$ | 178        | 114      | 110      | 575        | $^\circ\text{C/W}$ |
| Thermal Resistance, Junction to Case    | $R_{\theta JC}$ | 83         | 41       | 8        | 150        | $^\circ\text{C/W}$ |

● **RECOMMENDED OPERATING CONDITIONS**

| Condition/Value          | Symbol   | Min       | Max | Unit |
|--------------------------|----------|-----------|-----|------|
| Cathode to Anode Voltage | $V_{KA}$ | $V_{ref}$ | 36  | V    |
| Cathode Current          | $I_K$    | 1.0       | 100 | mA   |

● **ELECTRICAL CHARACTERISTICS**(Ambient temperature at  $25^\circ\text{C}$  unless otherwise noted)

| Characteristic                                                                                                                                                                                          | Symbol                                 | TL431                            |              |                                 | Unit |
|---------------------------------------------------------------------------------------------------------------------------------------------------------------------------------------------------------|----------------------------------------|----------------------------------|--------------|---------------------------------|------|
|                                                                                                                                                                                                         |                                        | Min                              | Typ          | Max                             |      |
| Reference Input Voltage (Fig 1)<br>$V_{KA}=V_{ref}$ , $I_K=10\text{mA}$<br>$T_A=+25^\circ\text{C}$ Tolerance 0.5%<br>1%<br>2%<br>$T_A=T_{low}$ to $T_{high}$ (Note 1)                                   | $V_{ref}$                              | 2.483<br>2.470<br>2.445<br>2.453 | 2.495<br>--  | 2.507<br>2.520<br>2.55<br>2.537 | V    |
| Reference Input Voltage Deviation Over Temperature Range (Fig 1, Note 1,2)<br>$V_{KA}=V_{ref}$ . $I_K=10\text{mA}$                                                                                      | $\Delta V_{ref}$                       | --                               | 3.0          | 17                              | mV   |
| Ratio of Change in Reference Input Voltage To Change in Cathode to Anode Voltage<br>$I_K=10\text{mA}$ (Figure 2), $\Delta V_{KA}=10\text{V}$ to $V_{ref}$<br>$\Delta V_{KA}=36\text{V}$ to $10\text{V}$ | $\frac{\Delta V_{ref}}{\Delta V_{KA}}$ | --<br>--                         | -1.4<br>-1.0 | -2.7<br>-2.0                    | mV/V |



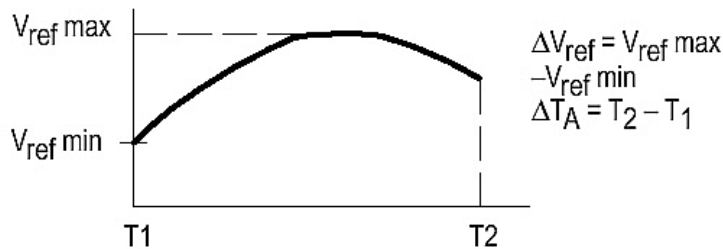
|                                                                                                                                                                            |                         |    |      |      |               |
|----------------------------------------------------------------------------------------------------------------------------------------------------------------------------|-------------------------|----|------|------|---------------|
| Reference Input Current (Figure 2)<br>$I_K=10\text{mA}$ , $R_1=10\text{k}$ , $R_2=\infty$<br>$T_A=+25^\circ\text{C}$<br>$T_A=T_{\text{low}}$ to $T_{\text{high}}$ (Note 1) | $I_{\text{ref}}$        | -- | 1.8  | 4.0  | $\mu\text{A}$ |
| Reference Input Current Deviation Over Temperature Range (Figure 2, Note 1)<br>$I_K=10\text{mA}$ , $R_1=10\text{k}$ , $R_2=\infty$                                         | $\Delta I_{\text{ref}}$ | -- | 0.4  | 1.2  | $\mu\text{A}$ |
| Minimum Cathode Current for Regulation<br>$V_{KA}=V_{\text{ref}}$ (Figure 1)                                                                                               | $I_{\text{min}}$        | -- | 0.5  | 1.0  | $\text{mA}$   |
| Off-State Cathode Current (Figure 3)<br>$V_{KA}=36\text{V}$ , $V_{\text{ref}}=0\text{V}$                                                                                   | $I_{\text{off}}$        | -- | 260  | 1000 | $\text{nA}$   |
| Dynamic Impedance (Figure 1, Note 3)<br>$V_{KA}=V_{\text{ref}}$ , $\Delta I_K=1.0\text{mA}$ to $100\text{mA}$ , $f_{\leq} 1.0\text{kHz}$                                   | $ Z_{KA} $              | -- | 0.22 | 0.5  | $\Omega$      |

1

$T_{\text{low}}=0^\circ\text{C}$ ,  $T_{\text{high}}=+70^\circ\text{C}$

2

The deviation parameter  $\Delta V_{\text{ref}}$  is defined as the differences between the maximum and minimum values obtained over the full operating ambient temperature range the applies.



The average temperature coefficient of the reference input voltage,  $\alpha V_{\text{ref}}$ , is defined as:

$$\alpha V_{\text{ref}} \frac{\text{ppm}}{^\circ\text{C}} = \frac{\frac{\Delta V_{\text{ref}}}{V_{\text{ref}} @ 25^\circ\text{C}} \times 10^6}{\Delta T_A} = \frac{\Delta V_{\text{ref}} \times 10^6}{\Delta T_A (V_{\text{ref}} @ 25^\circ\text{C})}$$

$\alpha V_{\text{ref}}$  can be positive or negative depending on whether  $V_{\text{ref}}$  Min or  $V_{\text{ref}}$  Max occurs at the lower ambient temperature. (Refer to Figure 6)

Example:  $\Delta V_{\text{ref}}=8.0\text{mV}$  and slope is positive,  $V_{\text{ref}} @ 25^\circ\text{C}=2.495\text{V}$ ,  $\Delta T_A=70^\circ\text{C}$

$$\alpha V_{\text{ref}} = \frac{0.008 \times 10^6}{70(2.495)} = 45.8 \text{ ppm}/^\circ\text{C}$$



3

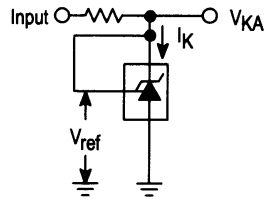
The dynamic impedance  $Z_{KA}$  is defined as:

$$|Z_{KA}| = \frac{\Delta V_{KA}}{\Delta I_K}$$

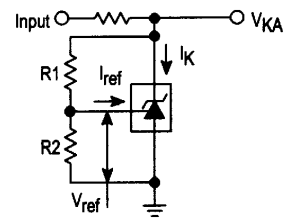
When the device is programmed with two external resistors,  $R1$  and  $r2$ , (refer to Figure 2) the total dynamic impedance of the circuit is defined as:

$$|Z_{KA}'| \approx |Z_{KA}| \left(1 + \frac{R1}{R2}\right)$$

## ● TEST CIRCUITS

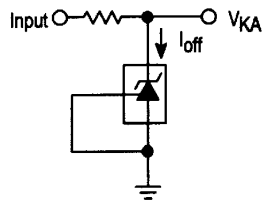


**Fig 1. Test Circuit for  $V_{KA}=V_{ref}$**



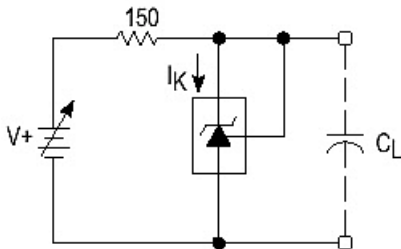
$$V_{KA} = V_{ref} \left(1 + \frac{R1}{R2}\right) + I_{ref} \cdot R1$$

**Fig 2. Test Circuit for  $V_{KA}>V_{ref}$**

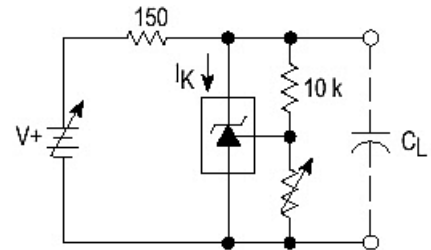


**Fig 3. Test Circuit for  $I_{off}$**

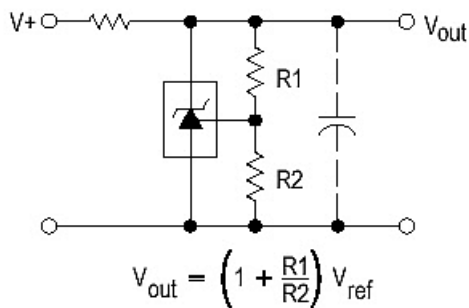
## ● APPLICATION EXAMPLE



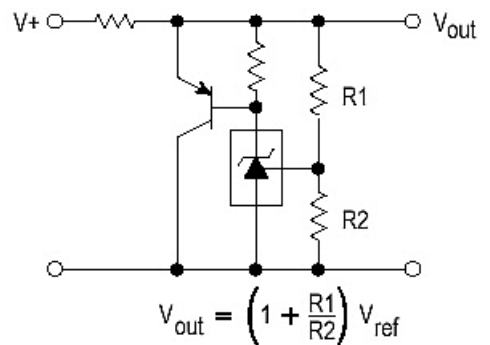
**Fig 4. Test circuit for curves A of stability boundary conditions**



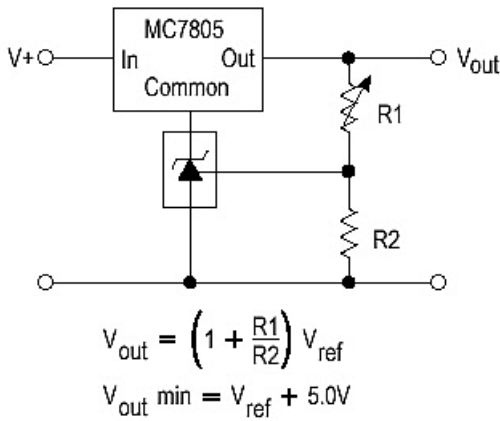
**Fig 5. Test circuit for curves B.C and D of stability boundary conditions**



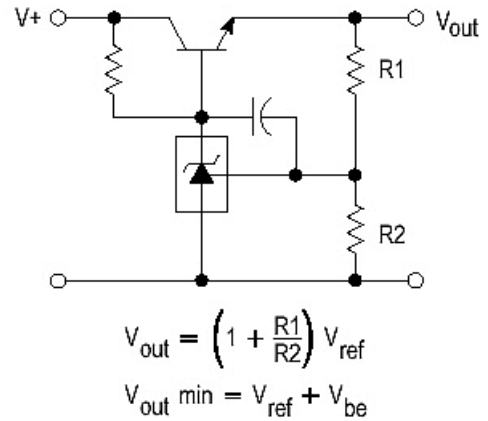
**Fig 6. Shunt regulator**



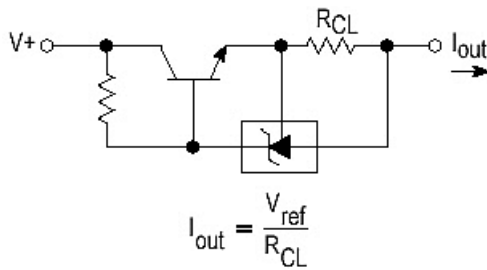
**Fig 7. High current shunt regulator**



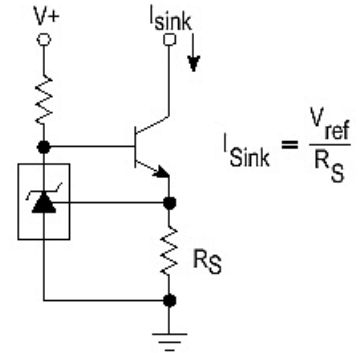
**Fig 8. Output control of a three-Terminal fixed regulator**



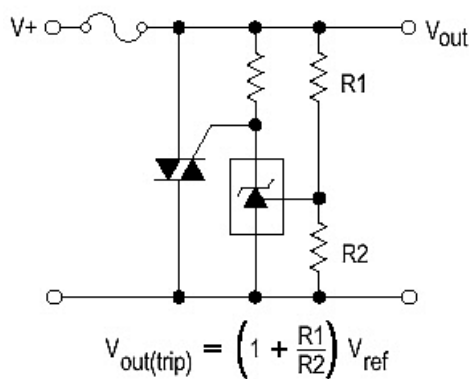
**Fig 9. Series pass regulator**



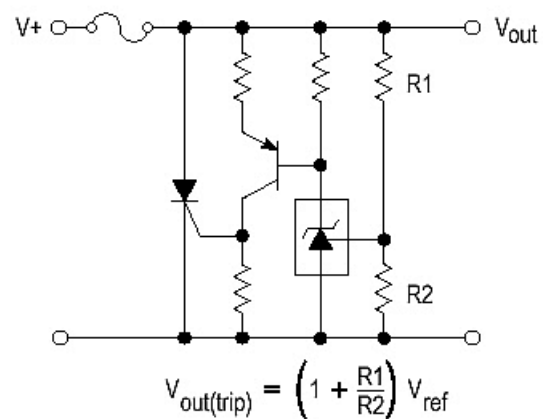
**Fig 10 .Constant current source**



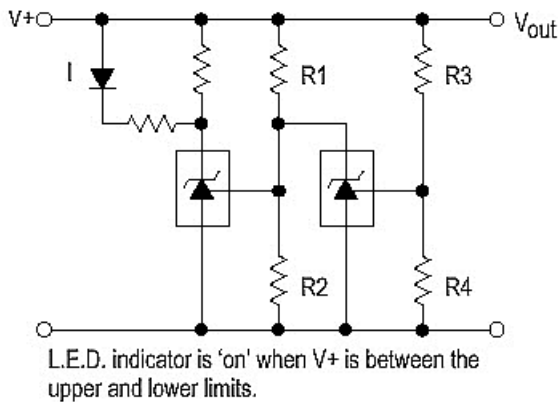
**Fig 11 .Constant current sink**



**Fig 12 .Triac crowbar**

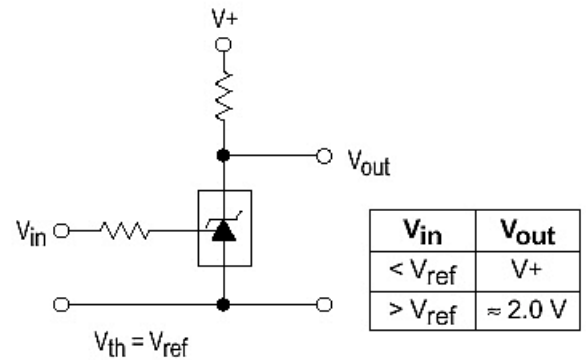


**Fig 13.SCR crowbar**

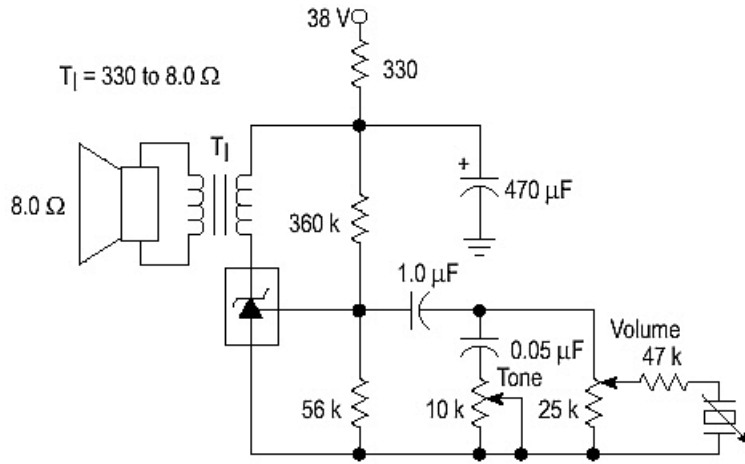


Upper Limit =  $\left(1 + \frac{R3}{R4}\right) V_{ref}$  Lower Limit =  $\left(1 + \frac{R1}{R2}\right) V_{ref}$

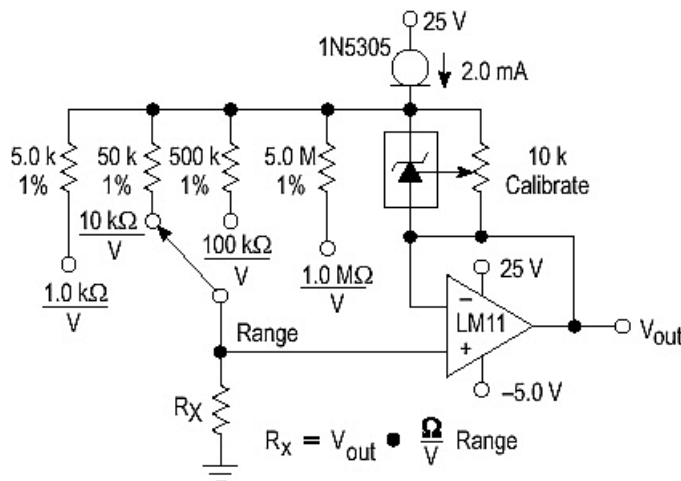
**Fig 14. Voltage monitor**



**Fig 15 . Single-supply comparator with temperature-compensated threshold**

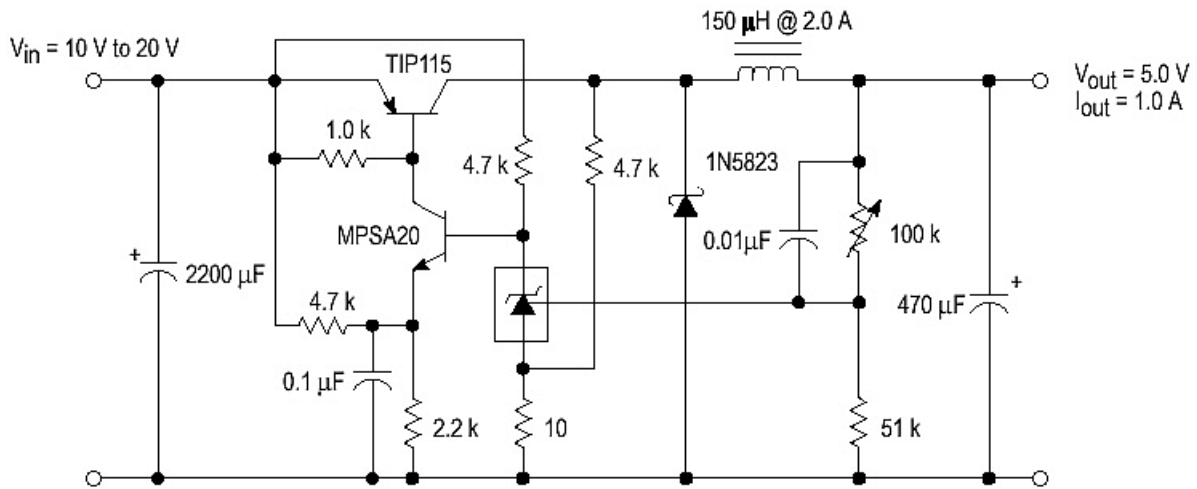


**Fig 16 .Simple 400mW phone amplifier**



**Fig 17. Liner ohmmeter**





| Test            | Conditions                      | Results                     |
|-----------------|---------------------------------|-----------------------------|
| Line Regulation | $V_{in}=10V$ to $20V, I_o=1.0A$ | 53mV (1.1%)                 |
| Load Regulation | $V_{in}=15V, I_o=0A$ to $1.0A$  | 25mV (0.5%)                 |
| Output Ripple   | $V_{in}=10V, I_o=1.0A$          | 50mV <sub>PP</sub> P.A.R.D  |
| Output Ripple   | $V_{in}=20V, I_o=1.0A$          | 100mV <sub>PP</sub> P.A.R.D |
| Efficiency      | $V_{in}=15V, I_o=1.0A$          | 82%                         |

**Fig 18.High efficiency step-down switching converter**



## ELECTRICAL CHARACTERISTICS CURVES

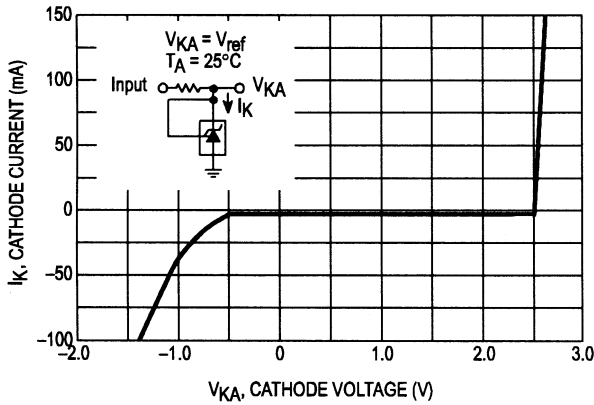


Fig 19. Cathode current versus cathode voltage

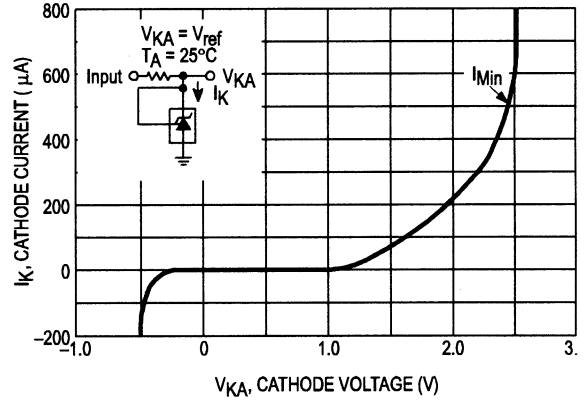


Fig 20. Cathode current versus cathode voltage

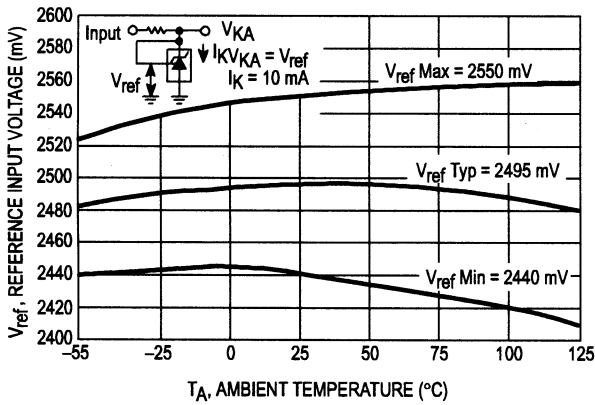


Fig 21. Reference input voltage versus ambient temperature

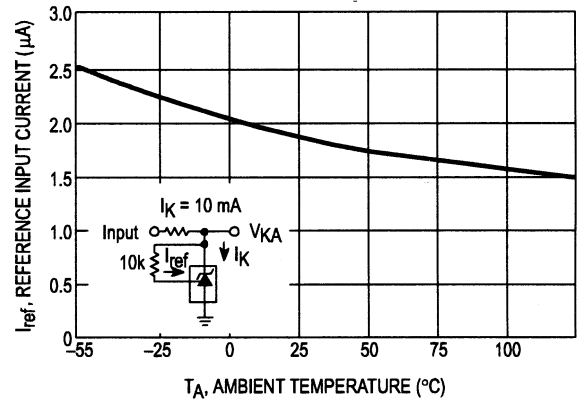


Fig 22. Reference input current versus ambient temperature

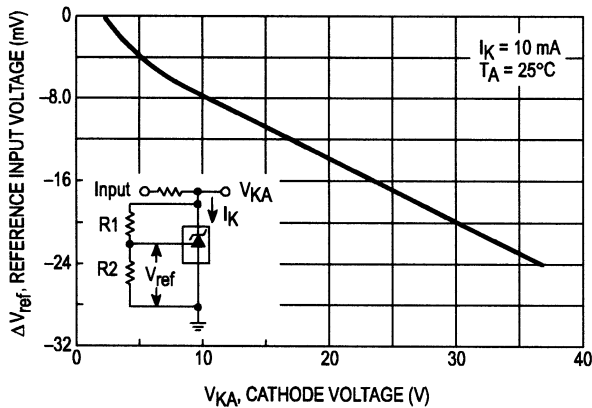


Fig 23. Change in reference input voltage versus Cathode voltage

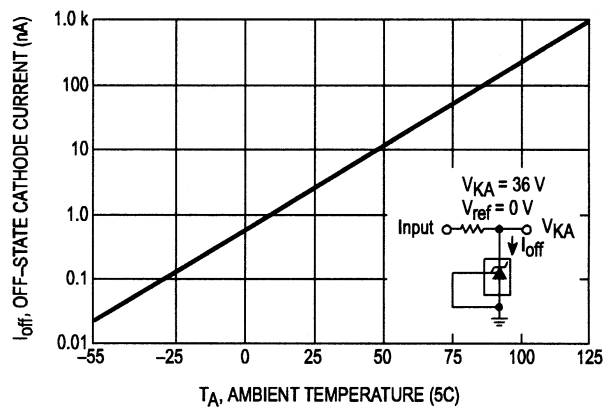


Fig 24. Off state cathode current versus ambient temperature

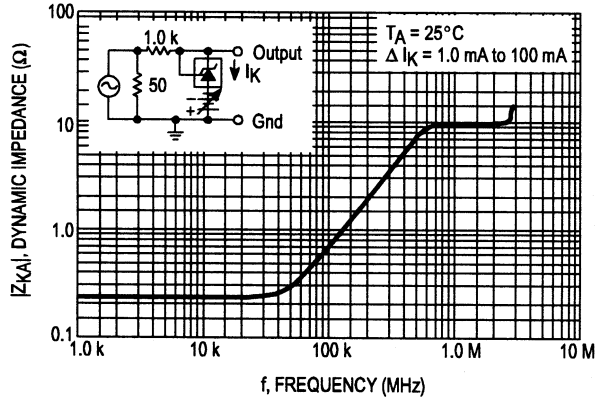


Fig 25. Dynamic impedance versus frequency

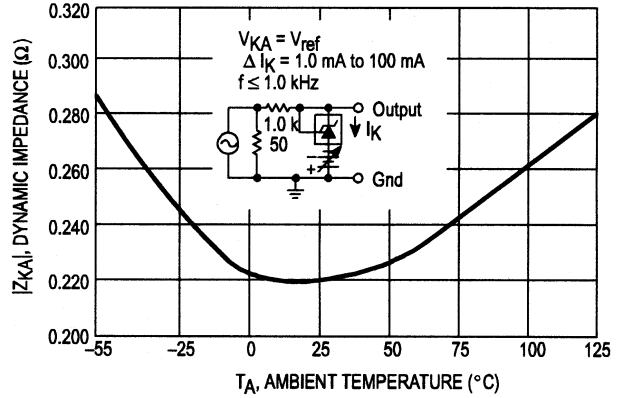


Fig 26. Dynamic impedance versus ambient temperature

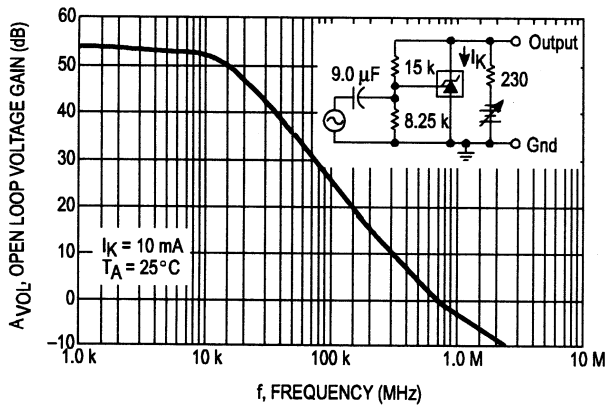


Fig 27. Open loop voltage gain versus frequency

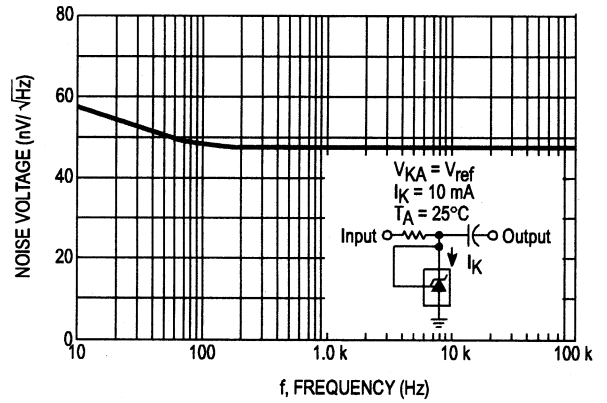


Fig 28. Spectral noise density

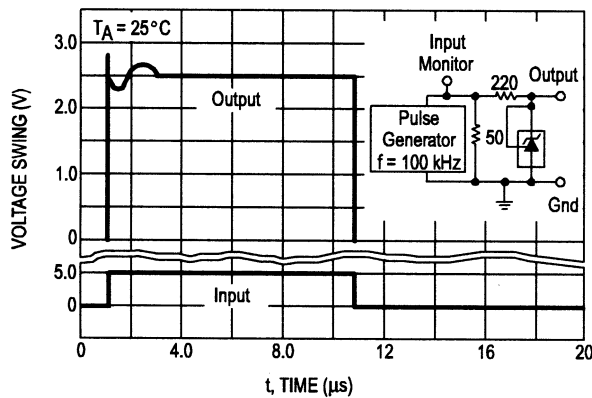


Fig 29. Pulse response

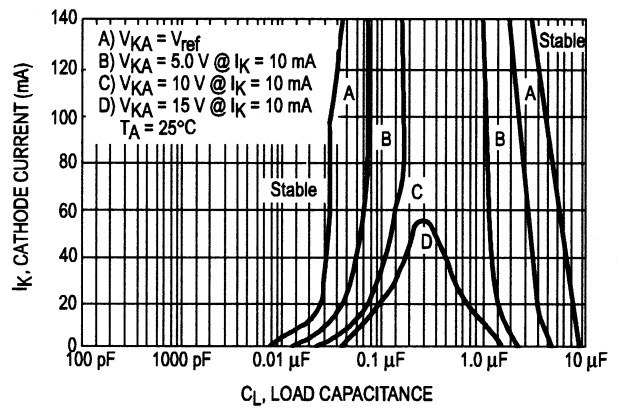


Fig 30. Stability boundary conditions



## ORDER INFORMATION

| DEVICE          | TEMPERATURE RANGE | PACKAGE |
|-----------------|-------------------|---------|
| TL431BCT 0.5%   | -20~+85°C         | TO-92   |
| TL431ACT 1%     | -20~+85°C         | TO-92   |
| TL431CT 2%      | -20~+85°C         | TO-92   |
| TL431BCP 0.5%   | -20~+85°C         | DIP-8   |
| TL431ACP 1%     | -20~+85°C         | DIP-8   |
| TL431CP 2%      | -20~+85°C         | DIP-8   |
| TL431BCD 0.5%   | -20~+85°C         | SOP-8   |
| TL431ACD 1%     | -20~+85°C         | SOP-8   |
| TL431CD 2%      | -20~+85°C         | SOP-8   |
| TL431BCLT1 0.5% | -20~+85°C         | SOT-23  |
| TL431ACL1 1%    | -20~+85°C         | SOT-23  |
| TL431CL1 2%     | -20~+85°C         | SOT-23  |
| TL431BCH 0.5%   | -20~+85°C         | SOT-89  |
| TL431ACH 1%     | -20~+85°C         | SOT-89  |
| TL431CH 2%      | -20~+85°C         | SOT-89  |



## Стандарт Электрон Связь

Мы молодая и активно развивающаяся компания в области поставок электронных компонентов. Мы поставляем электронные компоненты отечественного и импортного производства напрямую от производителей и с крупнейших складов мира.

Благодаря сотрудничеству с мировыми поставщиками мы осуществляем комплексные и плановые поставки широчайшего спектра электронных компонентов.

Собственная эффективная логистика и склад в обеспечивает надежную поставку продукции в точно указанные сроки по всей России.

Мы осуществляем техническую поддержку нашим клиентам и предпродажную проверку качества продукции. На все поставляемые продукты мы предоставляем гарантию .

Осуществляем поставки продукции под контролем ВП МО РФ на предприятия военно-промышленного комплекса России , а также работаем в рамках 275 ФЗ с открытием отдельных счетов в уполномоченном банке. Система менеджмента качества компании соответствует требованиям ГОСТ ISO 9001.

Минимальные сроки поставки, гибкие цены, неограниченный ассортимент и индивидуальный подход к клиентам являются основой для выстраивания долгосрочного и эффективного сотрудничества с предприятиями радиоэлектронной промышленности, предприятиями ВПК и научно-исследовательскими институтами России.

С нами вы становитесь еще успешнее!

### Наши контакты:

**Телефон:** +7 812 627 14 35

**Электронная почта:** [sales@st-electron.ru](mailto:sales@st-electron.ru)

**Адрес:** 198099, Санкт-Петербург,  
Промышленная ул, дом № 19, литера Н,  
помещение 100-Н Офис 331