



SP336E Evaluation Board Manual

Rev 2.1

11-23-10

Features

- Easy Evaluation of the SP336E Transceiver
- RS-232 and RS-485 Protocols
- Local or Remote Loop Back testing
- 10Mbps Differential Transmission Rates
- Test point for cable or jumper loop-back

Description

The SP336 Evaluation Board is designed to analyze the SP336 multi-protocol transceiver. The evaluation board provides access points to all of the driver and receiver I/O pins so that the user can measure electrical characteristics and waveforms of each signal. The evaluation board also has a switch to allow the user to select the mode of operation and slew control. Furthermore, the SP336 Evaluation Board provides the means to test both local and remote driver/receiver loop-back.

This Manual is split into sections to give the user the information necessary to perform a thorough evaluation of the SP336. The "Layout" section describes the I/O pins, jumpers and the other components used on the evaluation board. The layout diagram is also covered. The "Using the SP336 Evaluation Board" section details the configuration of the SP336 evaluation board for parametric testing.

Board Layout

Figure 1 – Evaluation Board Layout

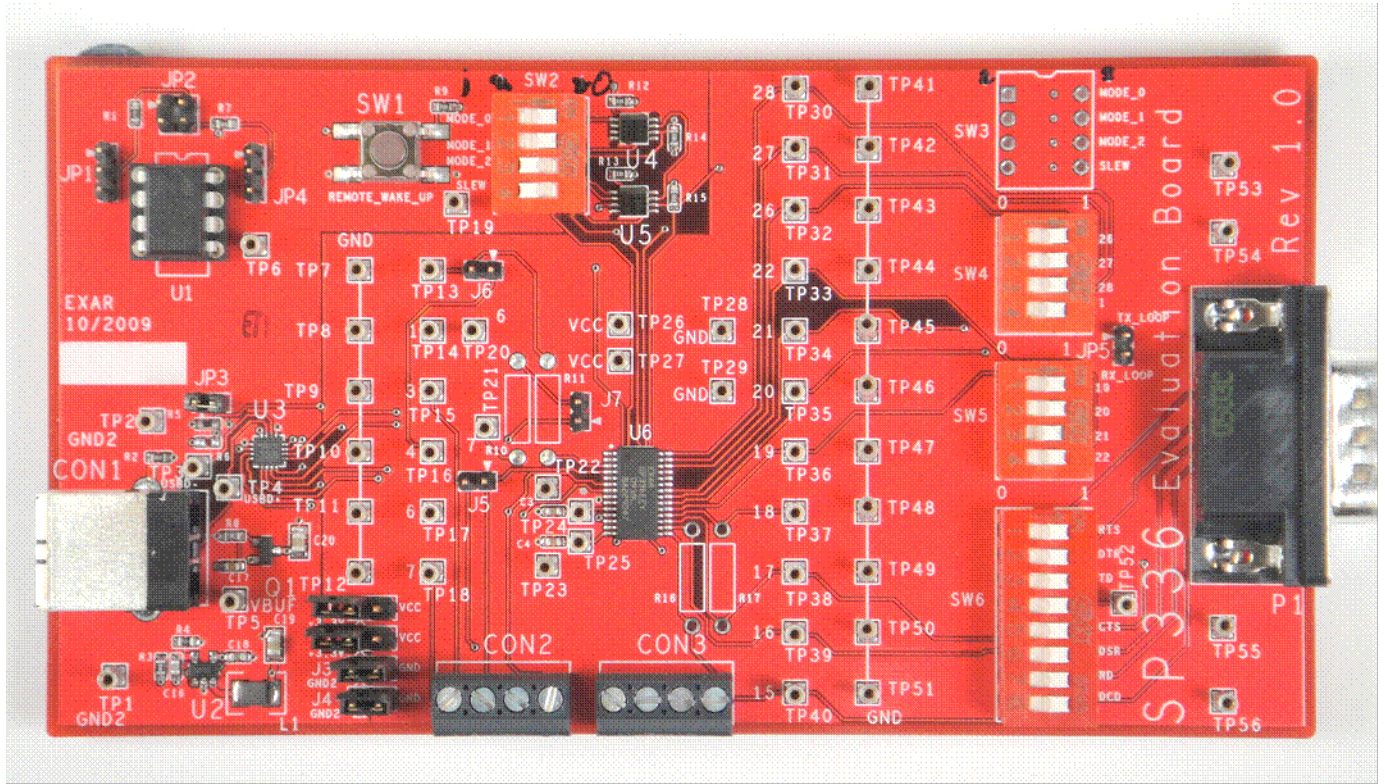

Table 1

TEST POINT	WHERE	DEVICE	PAIR TEST POINT	SIGNAL
TP32	T1_IN	U6-26	TP44	GND
TP31	T2_IN	U6-27	TP43	GND
TP30	T3_IN	U6-28	TP42	GND
TP14	T4_IN	U6-1	TP8	GND
TP36	R1_OUT	U6-19	TP48	GND
TP35	R2_OUT	U6-20	TP50	GND
TP34	R3_OUT	U6-21	TP45	GND
TP33	R4_OUT	U6-22	TP41	GND
TP17	T1_OUT	U6-6	TP11	GND
TP18	T2_OUT	U6-7	TP12	GND
TP16	T3_OUT	U6-4	TP10	GND
TP15	T4_OUT	U6-3	TP9	GND
TP40	R1_IN	U6-15	TP47	GND
TP39	R2_IN	U6-16	TP51	GND
TP38	R3_IN	U6-17	TP49	GND
TP37	R3_IN	U6-18	TP46	GND
TP27, TP26	VCC	U6-5		
TP28, TP29	GND	U6-8		
TP24	V+	U6-10 (C3)	TP22 (C3)	
TP25	V-	U6-14 (C4)	TP23 (C4)	
J1-2 & J2-2	VCC	Board		VCC
TP53, TP54, TP54, & TP56	GND	Board		GND
J3-2 & J4-2	GND	Board		GND

Table 2

Resistor	Header	Device	Mode Selected
R10	J7	U6-6&7	Mode 100
R11	J6	U6-3&4	Mode 010 & 100
R16		U6-15&16	Mode 101
R17		U6-17&18	Mode 011 & 101

Table 3

SW3-1	SW3-2	SW3-3	SW3-4		
MODE_0	MODE_1	MODE_3	SLEW		
0	0	0	x	Loopback TXin to RXout	Txout & Rxin High Impedance
0	0	1	x	RS-232 Mode	4T/4R RS232 Mode
0	1	0	x	Mixed Protocol, Half Duplex	2T/2R RS232 Mode & 1T/1R RS-485
0	1	1	x	Mixed Protocol, Full Duplex	2T/2R RS232 Mode & 1T/1R RS-485
1	0	0	x	RS-485/422 Half Duplex	2T/2R RS-485
1	0	1	x	RS-485/422 Full Duplex	2T/2R RS-485
1	1	0	x	Low Power, 4Rx Active	Driver at High Impedance
1	1	1	x	Low Power Shutdown	All I/O at High Impedance
x	x	x	0	RS-232 at 250kbps RS-485 at 250Kbps	
x	x	x	1	RS-232 at 1Mbps RS-485 at 10Mbps	

**Note: Mode set for zero, SW3 to the Right
Mode set for one, SW3 to the Left**

Using the SP336 Evaluation Board

MODE CONFIGURATION

The SP336 uses a 3 bit decoder to define the protocol selected. The mode selection truth table is shown in the data sheet and in Table 3. The SP336E supports eight distinct operating modes. Modes are set using the three Mode-Configuration input pins M0, M1, and M2, which correspond to SW3 (to the right is zero and to the left is one). The driver and receiver electrical characteristics and the pin functions change depending on the mode selected.

Figure 1- Mode Configuration

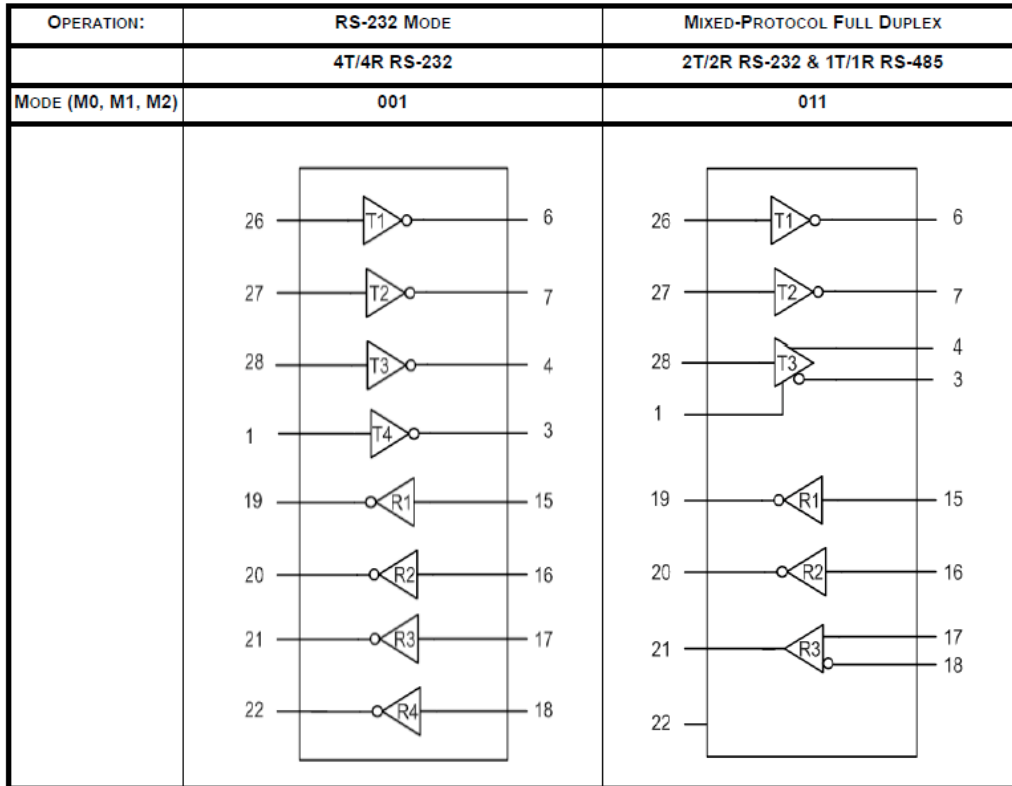

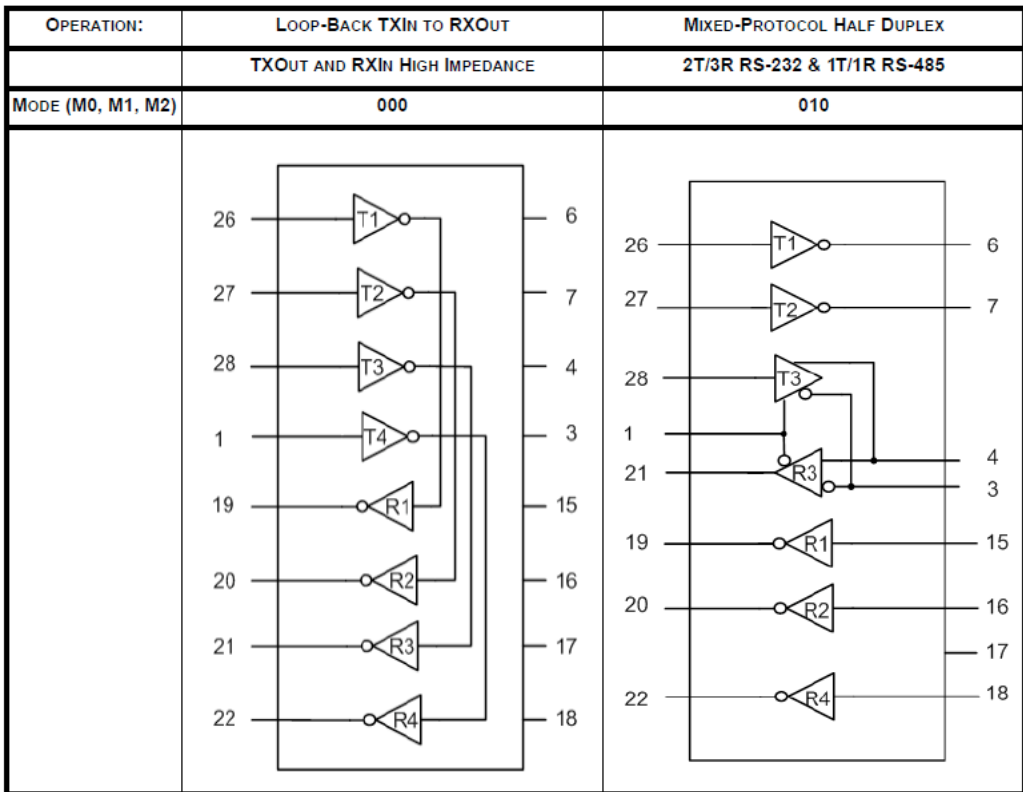
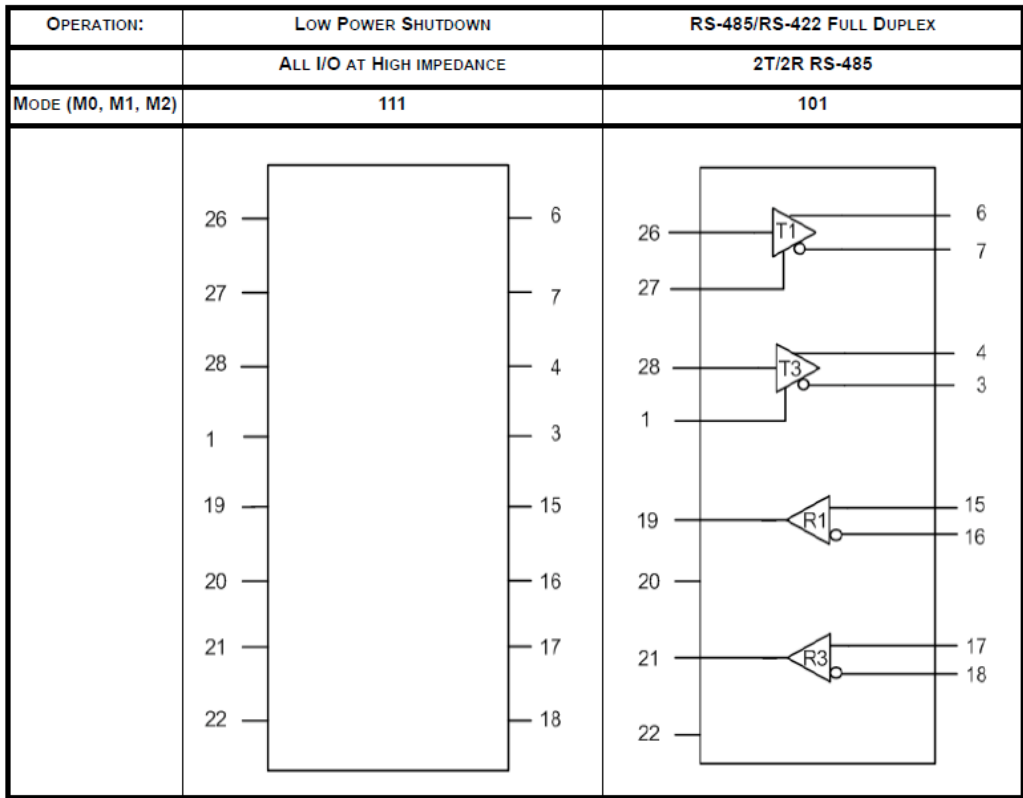

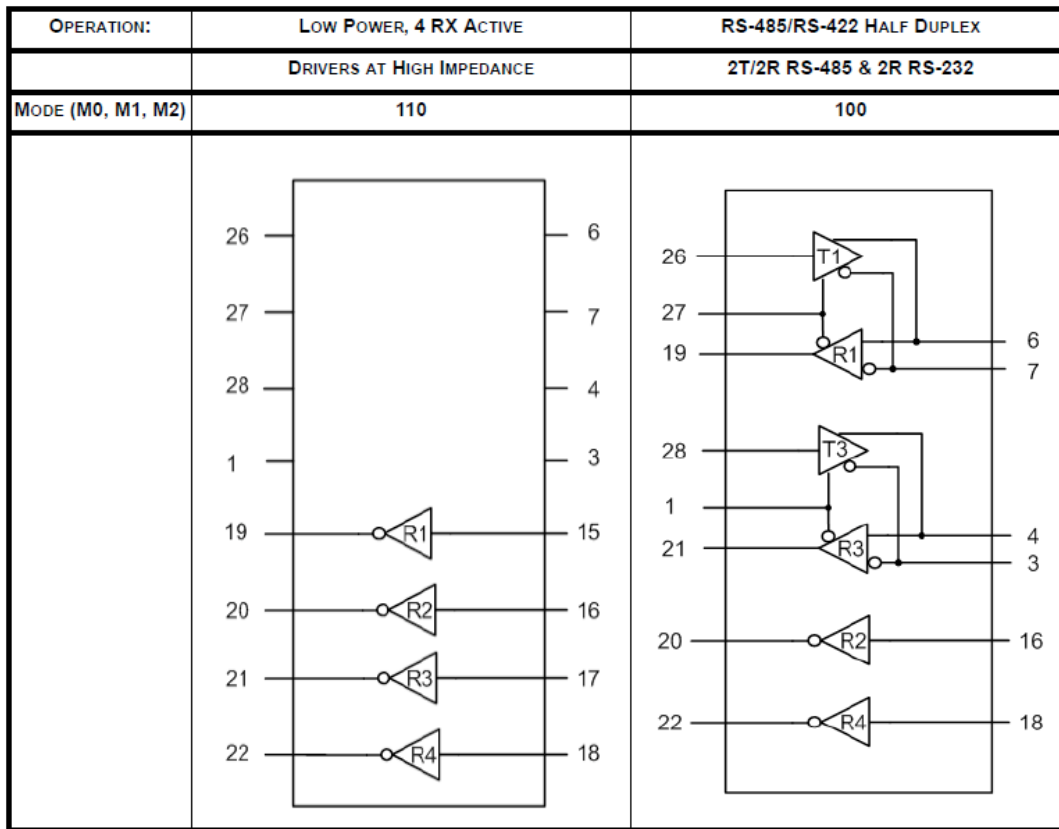

Table 2 is a matrix describing all the possible modes for the SP366 and lists the jumper settings for each mode. The Driver inputs, SLEW, MODE and the Loop back are all define an operating mode. The modes are listed in the first column. The inputs to T1_In (TP32 & TP44), T2_In (TP31 & TP43), T3_In (TP30 & TP42) and T4_In (TP14 & TP8) can be made using the 50 Ohm terminated resistor. Set the SP336 for the mode to be tested. Channels can also be connected high or low individually by the test points mention above and reference in Table 1.

Slew rate control for the SP336E drivers is logic selectable using the SLEW pin which is connected to SW3-4 “1”. Connecting SW3-4 (Left) provides high speed and no slew limiting while SW3-4 “0” (Right) limits the driver slew rate.

Local loop back diagnostic mode for RS232 is provided “on chip” by using logic programmable mode 000. Local loop back testing for RS485/422 mode is also provided on the evaluation board and can be implemented using the headers (Sw3-1 is Mode 0, SW3-2 is Mode 1 & SW3-3 is Mode 2). Set mode input logic to 101 to define RS485/422 mode. Follow Table 4 and jumper from test point to test point to Loopback.

Reference to Table 4:

Table 4

Device	Signal	Device	Signal
U6-6	T1_out TP17	U6-15	R1_in TP40
U6-7	T2_out TP21	U6-16	R2_in TP39
U6-4	T1_out TP16	U6-17	R3_in TP38
U6-3	T1_out TP15	U6-18	R4_in TP37

Refer to Table 1 for the desired inputs and outputs for loading. Loading the receiver outputs can be done thru test points on Table 4. Remember that the receiver acts as one load when connected to a driver output in a loop back configuration.

Table 5 – Pin Descriptions

Pin	Name	Type	Pin Functions		
			Single Ended	Full-Duplex	Half-Duplex
1	T4_In	TTL Input	T4 Driver Input	T3 Driver Enable Active High	T3 Driver Enable Active High, R3 Enable Active Low
2	Mode_1	TTL Input	Mode configuration pin 1		
3	T4_Out	Bus Driver	T4 Driver Output	T3(A) Output	
4	T3_Out	Bus Driver	T3 Driver Output	T3(B) Output	
5	Vcc	Supply	Power Supply Voltage		
6	T1_Out	Bus Driver	T1 Driver Output	T1(A) Output	
7	T2_Out	Bus Driver	T2 Driver Output	T1(B) Output	
8	GND	Supply	Ground		
9	C1+	Pump	Positive terminal of positive flying capacitor		
10	V+	Pump	Vdd of charge pump		
11	C2+	Pump	Positive terminal of negative flying capacitor		
12	C1-	Pump	Negative terminal of positive flying capacitor		
13	C2-	Pump	Negative terminal of negative flying capacitor		
14	V-	Pump	Vss of charge pump		
15	R1_In	Bus Receiver	R1 Receiver Input	R1(A) Receiver Input	Tri-State
16	R2_In	Bus Receiver	R2 Receiver Input	R1(B) Receiver Input	
17	R3_In	Bus Receiver	R3 Receiver Input	R3(A) Receiver Input	Tri-State
18	R4_In	Bus Receiver	R4 Receiver Input	R3(B) Receiver Input	
19	R1_Out	TTL Output	Receiver 1 Output		
20	R2_Out	TTL Output	Receiver 2 Output		
21	R3_Out	TTL Output	Receiver 3 Output		
22	R4_Out	TTL Input	Receiver 4 Output		
23	Mode_2	TTL Input	Mode configuration pin 2		
24	Mode_0	TTL Input	Mode configuration pin 0		
25	SLEW	TTL Input	Slew Rate Control. Logic low input will limit driver slew from either RS-232 or RS-485 to 250kbps		
26	T1_In	TTL Input	T1 Driver Input	T1 Driver Input	T1 Driver Input
27	T2_In	TTL Input	T2 Driver Input or T1 Driver Enable	T1 Driver Enable Active High	T1 Driver Enable Active High, R1 Enable Active Low
28	T3_In	TTL Input	T3 Driver Input	T3 Driver Input	T3 Driver Input



Стандарт Электрон Связь

Мы молодая и активно развивающаяся компания в области поставок электронных компонентов. Мы поставляем электронные компоненты отечественного и импортного производства напрямую от производителей и с крупнейших складов мира.

Благодаря сотрудничеству с мировыми поставщиками мы осуществляем комплексные и плановые поставки широчайшего спектра электронных компонентов.

Собственная эффективная логистика и склад в обеспечивает надежную поставку продукции в точно указанные сроки по всей России.

Мы осуществляем техническую поддержку нашим клиентам и предпродажную проверку качества продукции. На все поставляемые продукты мы предоставляем гарантию .

Осуществляем поставки продукции под контролем ВП МО РФ на предприятия военно-промышленного комплекса России , а также работаем в рамках 275 ФЗ с открытием отдельных счетов в уполномоченном банке. Система менеджмента качества компании соответствует требованиям ГОСТ ISO 9001.

Минимальные сроки поставки, гибкие цены, неограниченный ассортимент и индивидуальный подход к клиентам являются основой для выстраивания долгосрочного и эффективного сотрудничества с предприятиями радиоэлектронной промышленности, предприятиями ВПК и научно-исследовательскими институтами России.

С нами вы становитесь еще успешнее!

Наши контакты:

Телефон: +7 812 627 14 35

Электронная почта: sales@st-electron.ru

Адрес: 198099, Санкт-Петербург,
Промышленная ул, дом № 19, литера Н,
помещение 100-Н Офис 331