



MAX16821B Evaluation Kit

General Description

The MAX16821B evaluation kit (EV kit) is a fully assembled and tested surface-mount printed-circuit board (PCB) designed to evaluate the MAX16821B pulse-width-modulation (PWM) LED driver controller in a boost configuration.

The MAX16821B EV kit operates from a DC supply voltage of 7V to 24V. The EV kit's output is configured to deliver 660mA of current into series LED string with a maximum forward voltage of 28V. The LED brightness can be dimmed using a digital PWM signal.

The EV kit provides an option to configure the MAX16821B IC's overvoltage protection, switching frequency, and frequency compensation. The MAX16821B EV kit also features a clock output PCB pad to drive a second LED current regulator out-of-phase.

Features

- ◆ 7V to 24V Input-Voltage Range
- ◆ 660mA Output Current
- ◆ Pulse-Width-Modulated LED Current Dimming
- ◆ Resistor-Adjustable Overvoltage Protection and Switching Frequency
- ◆ Clock Output
- ◆ Fully Assembled and Tested

Ordering Information

PART	TYPE
MAX16821BEVKIT+	EV Kit

+Denotes lead-free and RoHS-compliant.

Component List

DESIGNATION	QTY	DESCRIPTION
C1, C5, C6	3	10 μ F \pm 10%, 50V X7S ceramic capacitors (1210) Taiyo Yuden UMK325BJH106K
C2	1	0.1 μ F \pm 10%, 50V X7R ceramic capacitor (1206) Murata GRM319R71H104K
C3, C4	2	1000pF \pm 10%, 25V X7R ceramic capacitors (0603) Murata GRM188R71E102K
C7	1	0.022 μ F \pm 10%, 50V X7R ceramic capacitor (0603) Murata GRM188R71H223K
C8	1	4.7 μ F \pm 10%, 6.3V X7R ceramic capacitor (0603) Murata GRM188R70J475K
C9, C10	2	0.1 μ F \pm 10%, 50V X7R ceramic capacitors (0603) Murata GRM188R71H104K
D1	1	3A, 60V Schottky diode (SMA) Diodes Inc. B360A-13-F

DESIGNATION	QTY	DESCRIPTION
L1	1	8.8 μ H, 4A inductor Sumida CDEP105-8R8
N1-N4	4	60V, 115mA n-channel MOSFETs (SOT23) Central Semiconductor 2N7002 LEAD-FREE
N5	1	40V, 4.9A n-channel MOSFET (8-pin SO) Vishay Si4446DY
N6	1	60V, 3.2A n-channel MOSFET (6-pin TSOP) Vishay Si3458DV-E3
R1	1	249k Ω \pm 1% resistor (0603)
R2, R5, R10	3	10k Ω \pm 1% resistors (0603)
R3	0	Not installed, resistor—shorted (0603)
R4	1	124k Ω \pm 1% resistor (0603)
R6	1	0.007 Ω \pm 2%, 0.5W sense resistor (1206) IRC LRC-LRF1206LF-01-R007-G

Evaluates: MAX16821B

MAX16821B Evaluation Kit

Component List (continued)

DESIGNATION	QTY	DESCRIPTION
R7	1	0.15Ω ±1%, 0.5W sense resistor (1206) IRC LRC-LRC1206LF-01-R150-F
R8	1	1Ω ±5% resistor (0603)
R9	1	2kΩ ±1% resistor (0603)
R11	1	2.49kΩ ±1% resistor (0603)
R12	1	1.24kΩ ±1% resistor (0603)

DESIGNATION	QTY	DESCRIPTION
R13	1	1kΩ ±1% resistor (0603)
U1	1	Maxim PWM LED driver controller MAX16821BATI+ (28-pin thin QFN-EP*, 5mm x 5mm x 0.8mm)
—	1	PCB: MAX16821B Evaluation Kit+

*EP = Exposed pad.

Component Suppliers

SUPPLIER	PHONE	WEBSITE
Central Semiconductor Corp.	631-435-1110	www.centralsemi.com
Diodes Inc.	805-446-4800	www.diodes.com
IRC Inc.	361-992-7900	www.irctt.com
Murata Mfg. Co., Ltd.	770-436-1300	www.murata.com
Sumida Corp.	847-545-6700	www.sumida.com
Taiyo Yuden	800-348-2496	www.t-yuden.com
Vishay	203-268-6261	www.vishay.com

Note: Indicate that you are using the MAX16821B when contacting these component suppliers.

Quick Start

Recommended Equipment

Before beginning, the following equipment is needed:

- 7V to 24V, 4A DC power supply
- One series-connected LED string rated at 660mA (28V maximum LED voltage)
- One current probe to measure LED current
- One voltmeter

Procedure

The MAX16821B EV kit is fully assembled and tested. Follow the steps below to verify board operation.

Caution: Do not turn on the power supply until all connections are completed.

- 1) Connect the positive terminal of the power supply to the VIN pad on the EV kit. Connect the negative terminal of the power supply to the PGND pad next to the VIN pad.
- 2) Connect the anode end of the LED string to the LED+ pad.
- 3) Connect the cathode end of the LED string to the LED- pad.

- 4) Clip the current probe across the string wires to measure the LED current.
- 5) Turn on the power supply and increase the voltage to 7V or above.
- 6) Verify that the LED string DC current is approximately 660mA.
- 7) Measure the voltage between the LED+ to LED- PCB pads.

Detailed Description

The MAX16821B EV kit circuit is designed to evaluate the MAX16821B PWM LED driver controller. The EV kit is configured in a boost topology and provides 660mA LED current for a string of user-supplied external high-brightness LEDs (HBLEDs) rated up to 28V. The MAX16821B EV kit operates from a DC supply voltage of 7V to 28V.

The EV kit average input current is set to 3.75A using resistor R6. The LED current is set to 660mA using resistor R7. A PWMDIM PCB pad is provided for PWM dimming operation of the external LEDs. A CLKOUT PCB pad is also available to drive a second LED current regulator 180° out-of-phase with the first EV kit.

MAX16821B Evaluation Kit

Evaluate: MAX16821B

LED Output Current

The MAX16821B delivers 660mA into an LED string rated up to a maximum of 28V. Resistor R7 sets the MAX16821B EV kit LED output current. Use the following equation to calculate R7 when reconfiguring the LED current:

$$R7 = \frac{100\text{mV}}{I_{\text{LED}}}$$

where 100mV is the MAX16821B regulated SENSE+ to SENSE- differential current-sense voltage and I_{LED} is the desired LED current.

Input Current-Limit Setting

Current-sense resistor R6 sets the EV kit's circuit average input current limit to 3.75A. During an overload condition at low line, the MAX16821B regulates the average input current to 3.75A. Use the following equation to calculate a new R6 value when reconfiguring the input current limit:

$$R6 = \frac{26.4\text{mV}}{I_{\text{IN}}}$$

where I_{IN} is the input current limit.

For additional information, refer to the *Average Current Limit* section in the MAX16821A/MAX16821B/MAX16821C IC data sheet for setting the input current limit when configuring the MAX16821B in a boost configuration.

LED Brightness Dimming

The LED brightness can be dimmed using a PWM signal with a 5V logic-high level and frequency range of 100Hz to 5kHz. Connect the PWM signal to the PWMDIM and SGND PCB pads to control the LEDs' brightness.

Output Overvoltage Protection

The maximum voltage on the LED+ pin is limited to 33V, with respect to GND, by a resistor feedback network formed by resistors R1 and R2. When the voltage at

LED+ exceeds the programmed 33V threshold, the low-side driver turns off to prevent current through the LED string connected between LED+ and LED-. Use the following equation to calculate R1 and R2 resistor values for a new overvoltage threshold:

$$R1 = R2 \times \frac{(V_{\text{OV_LIM}} - V_{\text{OV}})}{V_{\text{OV}}}$$

where $V_{\text{OV_LIM}}$ is the desired overvoltage threshold, R2 is typically 10k Ω , and V_{OV} is 1.276V.

Switching Frequency

The MAX16821B EV kit switching frequency (f_{sw}) is configured to 500kHz by resistor R4. To reconfigure the MAX16821B switching frequency from 125kHz to 1.5MHz, use the equations below to calculate the new value for R4:

$$R4 = \frac{6.4 \times 10^{10}}{f_{\text{sw}}}, \text{ for } 40\text{k}\Omega \leq R4 \leq 120\text{k}\Omega$$
$$R4 = \frac{6.25 \times 10^{10}}{f_{\text{sw}}}, \text{ for } 120\text{k}\Omega \leq R4 \leq 500\text{k}\Omega$$

where f_{sw} is the desired switching frequency.

When reconfiguring the MAX16821B EV kit switching frequency, other components may need to be changed for proper stable operation.

Clock Output

The MAX16821B EV kit also features a clock output signal that is 180° out-of-phase with respect to MOSFET N5. The clock output is available at the CLKOUT PCB pad. Use the SGND PCB pad as a reference ground for the CLKOUT signal.

Output Enable (EN)

The MAX16821B is enabled through pullup resistor R5. To disable the MAX16821B EV kit, connect the EN PCB pad to the SGND pad.

MAX16821B Evaluation Kit

Evaluates: MAX16821B

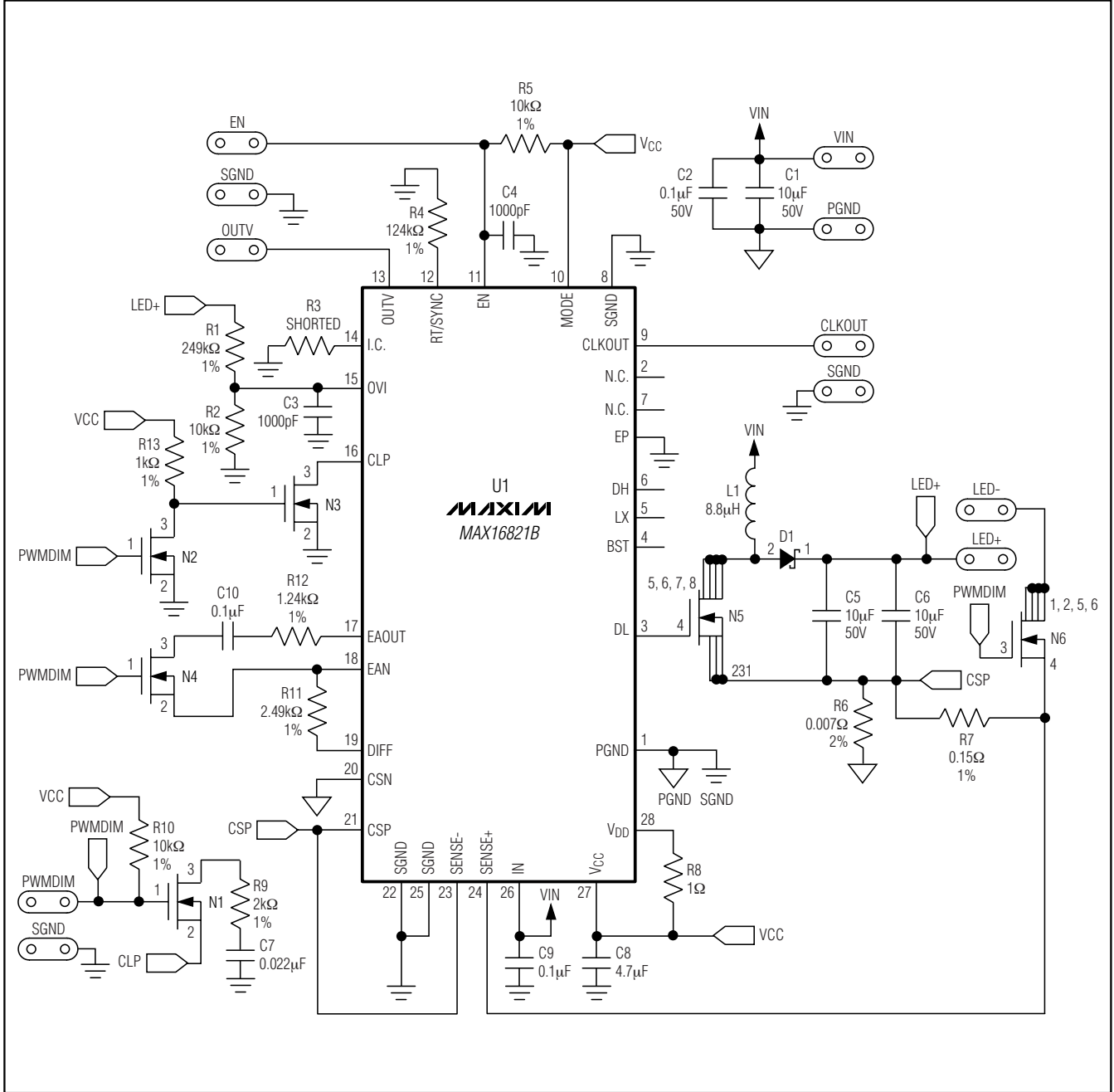

Figure 1. MAX16821B EV Kit Schematic

MAX16821B Evaluation Kit

Evaluates: MAX16821B

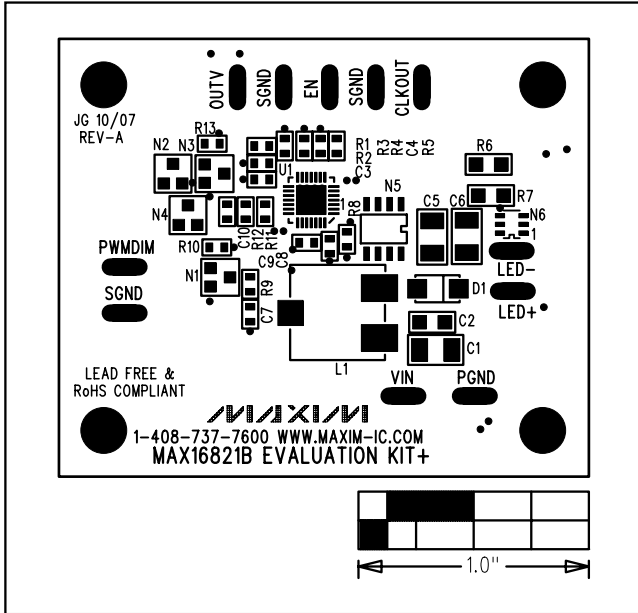

Figure 2. MAX16821B EV Kit Component Placement Guide—Component Side

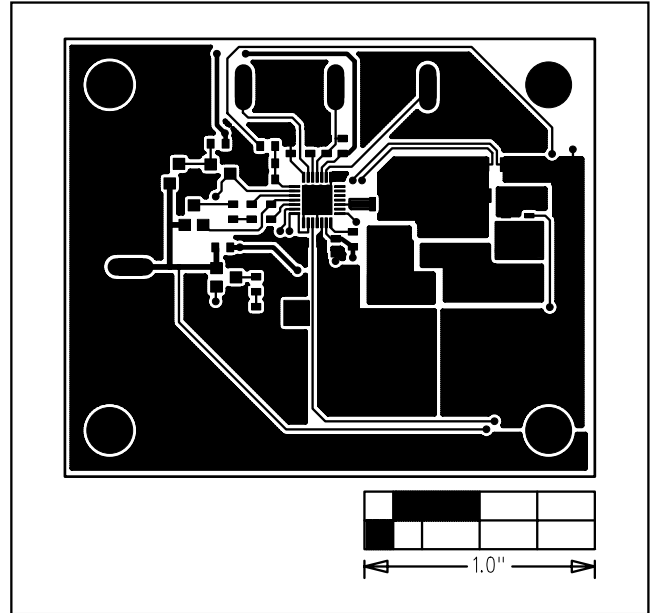

Figure 3. MAX16821B EV Kit PCB Layout—Component Side

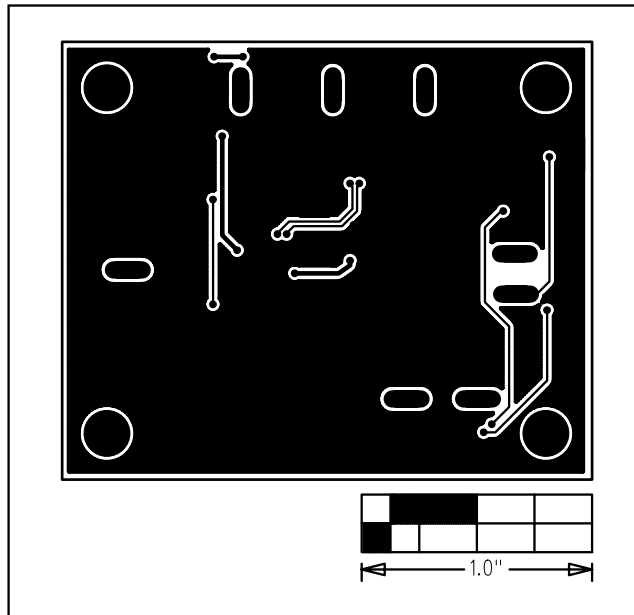

Figure 4. MAX16821B EV Kit PCB Layout—Solder Side

Maxim cannot assume responsibility for use of any circuitry other than circuitry entirely embodied in a Maxim product. No circuit patent licenses are implied. Maxim reserves the right to change the circuitry and specifications without notice at any time.

Maxim Integrated Products, 120 San Gabriel Drive, Sunnyvale, CA 94086 408-737-7600 _____ 5



Стандарт Электрон Связь

Мы молодая и активно развивающаяся компания в области поставок электронных компонентов. Мы поставляем электронные компоненты отечественного и импортного производства напрямую от производителей и с крупнейших складов мира.

Благодаря сотрудничеству с мировыми поставщиками мы осуществляем комплексные и плановые поставки широчайшего спектра электронных компонентов.

Собственная эффективная логистика и склад в обеспечивает надежную поставку продукции в точно указанные сроки по всей России.

Мы осуществляем техническую поддержку нашим клиентам и предпродажную проверку качества продукции. На все поставляемые продукты мы предоставляем гарантию .

Осуществляем поставки продукции под контролем ВП МО РФ на предприятия военно-промышленного комплекса России , а также работаем в рамках 275 ФЗ с открытием отдельных счетов в уполномоченном банке. Система менеджмента качества компании соответствует требованиям ГОСТ ISO 9001.

Минимальные сроки поставки, гибкие цены, неограниченный ассортимент и индивидуальный подход к клиентам являются основой для выстраивания долгосрочного и эффективного сотрудничества с предприятиями радиоэлектронной промышленности, предприятиями ВПК и научно-исследовательскими институтами России.

С нами вы становитесь еще успешнее!

Наши контакты:

Телефон: +7 812 627 14 35

Электронная почта: sales@st-electron.ru

Адрес: 198099, Санкт-Петербург,
Промышленная ул, дом № 19, литера Н,
помещение 100-Н Офис 331