

Cree® XLamp® XM-L Color LEDs



PRODUCT DESCRIPTION

The XLamp XM-L Color LED is a multi-color LED that provides high lumen output in a small package. Compared to discrete LEDs, XLamp XM-L Color LEDs reduce the distance between LED die, creating a small optical source for excellent optical control and efficient color mixing. XLamp XM-L Color LEDs can reduce LED system complexity by reducing the number of components required.

Cree XLamp XM-L Color LEDs bring high performance and quality of light to a wide range of lighting applications, including color-changing lighting, stage lighting, architectural lighting, indoor directional lighting, and entertainment lighting.

FEATURES

- Available in red, green, blue and white in a single 5 mm x 5 mm package
- Maximum drive current per LED die: 1 A
- Individually addressable LEDs
- Reflow solderable – JEDEC J-STD-020
- Electrically neutral thermal path

TABLE OF CONTENTS

Flux Characteristics.....	2
Characteristics - Complete Package	2
Characteristics - Per LED Die.....	3
Relative Spectral Power Distribution.....	3
Relative Flux vs Junction Temperature	4
Electrical Characteristics	4
Relative Flux vs. Current	5
Typical Spatial Distribution.....	5
Bin and Order-Code Formats	6
Performance Groups – Brightness	6
Performance Groups – Chromaticity	7
Performance Groups – Dominant Wavelength	7
Standard Order Codes and Bins ...	8
Reflow Soldering Characteristics ..	9
Mechanical Dimensions.....	10
Tape and Reel	11
Packaging.....	12

FLUX CHARACTERISTICS, (T_j = 25 °C)

The following tables provide several base order codes for XM-L Color LEDs. For a complete description of the order code nomenclature, please refer to the Bin and Order Code Formats section (page 6).

Color		CCT / Dominant Wavelength Range		Base order codes Min. Luminous Flux @ 350 mA		Order Code
		Min.	Max.	Group	Flux (lm)	
Color + Cool White	Red	620 nm	630 nm	C3	45.7	XMLCTW-A0-0000-00C3AAAA1
	Green	520 nm	535 nm		87.4	
	Blue	450 nm	465 nm		13.9	
	Cool White	5700 K	8000 K		100	
Color + Neutral White	Red	620 nm	630 nm	C2	45.7	XMLCTW-A0-0000-00C2AAAB1
	Green	520 nm	535 nm		87.4	
	Blue	450 nm	465 nm		13.9	
	Neutral White	3700 K	4300 K		80	

Notes:

- Cree maintains a tolerance of $\pm 7\%$ on flux and power measurements and ± 0.005 on chromaticity (CC_x, CC_y) measurements.
- Flux and chromaticity are measured with each LED die connected to independent drive circuits at 350 mA. The flux and chromaticity of each LED die within the XLamp XM-L Color LED package are measured individually.

CHARACTERISTICS - COMPLETE PACKAGE

The following table lists the product characteristics for the XLamp XM-L Color LED package, measured with all LED dies on simultaneously and each LED die connected to independent drive circuits at 350 mA.

Characteristics	Unit	Minimum	Typical	Maximum
Thermal resistance, junction to solder point	°C/W		3.5	
Viewing angle (FWHM)	degrees (°)		130	
ESD classification (HBM per Mil-Std-883D)			Class 2	
LED junction temperature	°C			150

CHARACTERISTICS - PER LED DIE

The following table lists the product characteristics for each LED die within the XLamp XM-L Color LED package.

Characteristics	Unit	Minimum	Typical	Maximum
Temperature coefficient of voltage - red	mV/°C		-1.8	
Temperature coefficient of voltage - green	mV/°C		-4	
Temperature coefficient of voltage - blue, white	mV/°C		-3	
DC forward current - red, green, blue, white	mA			1000
Forward voltage (@ 350 mA, 25 °C) - red	V		2.25	2.6
Forward voltage (@ 350 mA, 25 °C) - green	V		3.3	3.9
Forward voltage (@ 350 mA, 25 °C) - blue, white	V		3.1	3.7

RELATIVE SPECTRAL POWER DISTRIBUTION ($I_f = 350 \text{ mA}$ PER LED DIE, 25 °C)

The following graph represents typical spectral output of the XLamp XM-L Color LED with each LED die on independently.

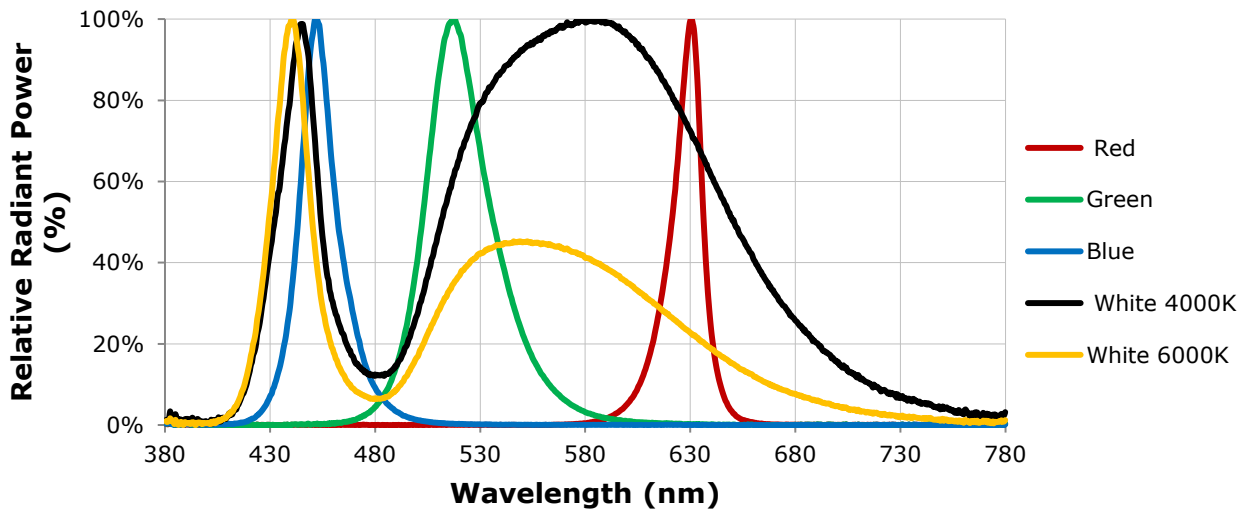

RELATIVE FLUX VS JUNCTION TEMPERATURE ($I_f = 350 \text{ mA}$)

The following graph represents typical performance of each LED die in the XLamp XM-L Color LED.

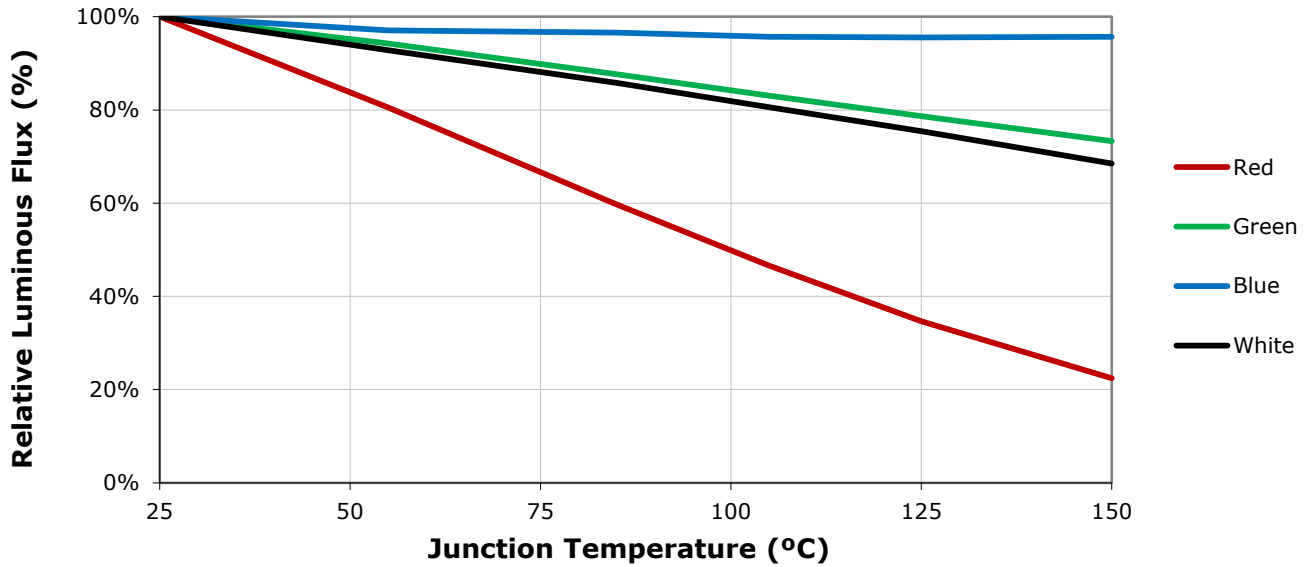

ELECTRICAL CHARACTERISTICS ($T_j = 25 \text{ °C}$)

The following graph represents typical performance of each LED die in the XLamp XM-L Color LED.

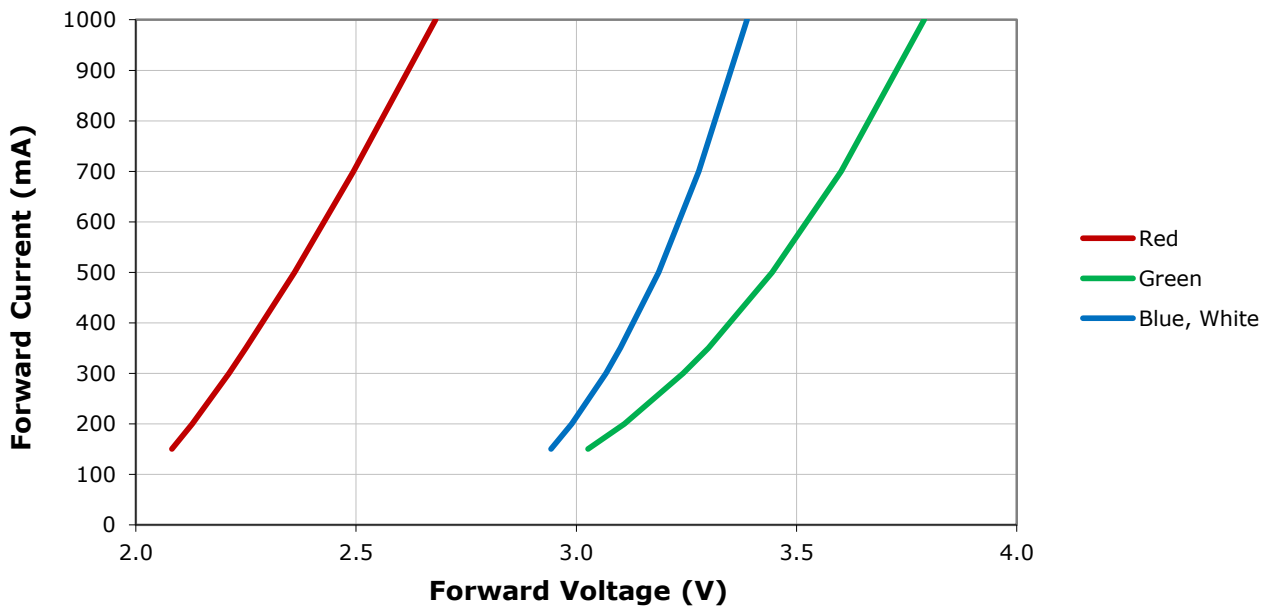

RELATIVE FLUX VS. CURRENT ($T_j = 25^\circ\text{C}$)

The following graph represents typical performance of each LED die in the XLamp XM-L Color LED.

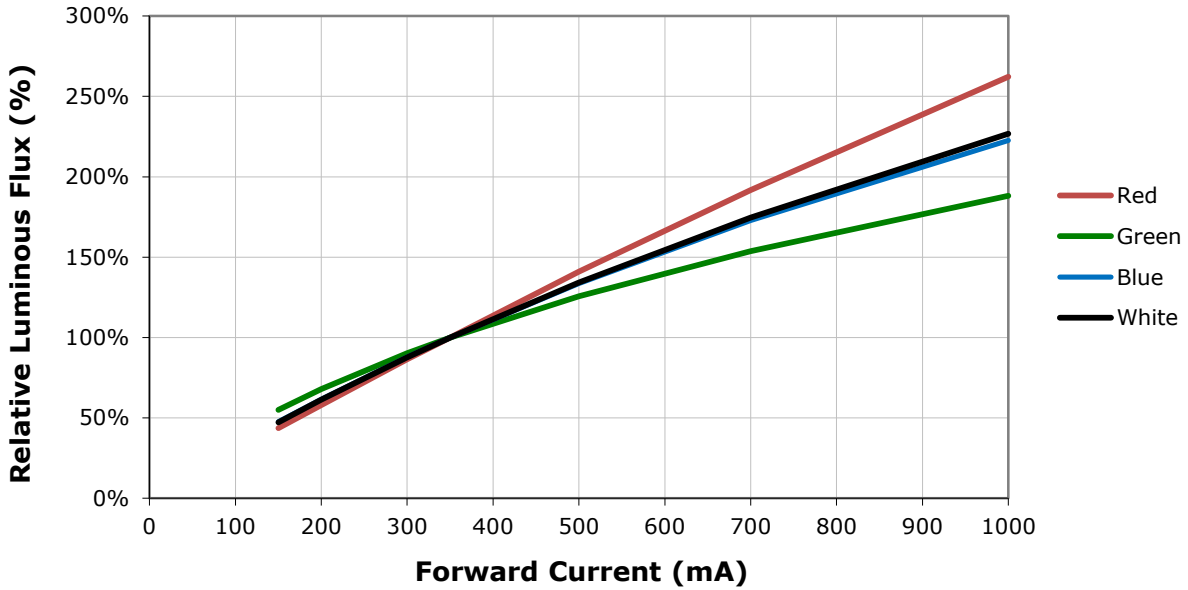

TYPICAL SPATIAL DISTRIBUTION

The following graph represents typical output of the XLamp XM-L Color LED with all four LEDs on simultaneously.

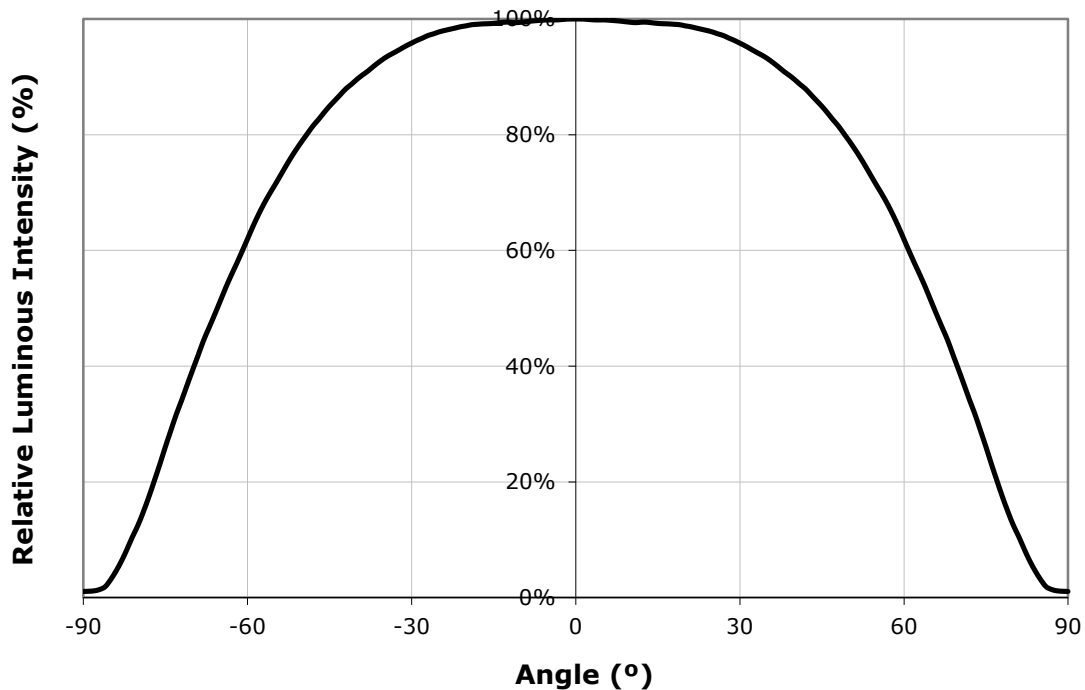

BIN AND ORDER-CODE FORMATS

Bin codes and order codes are configured in the following manner:

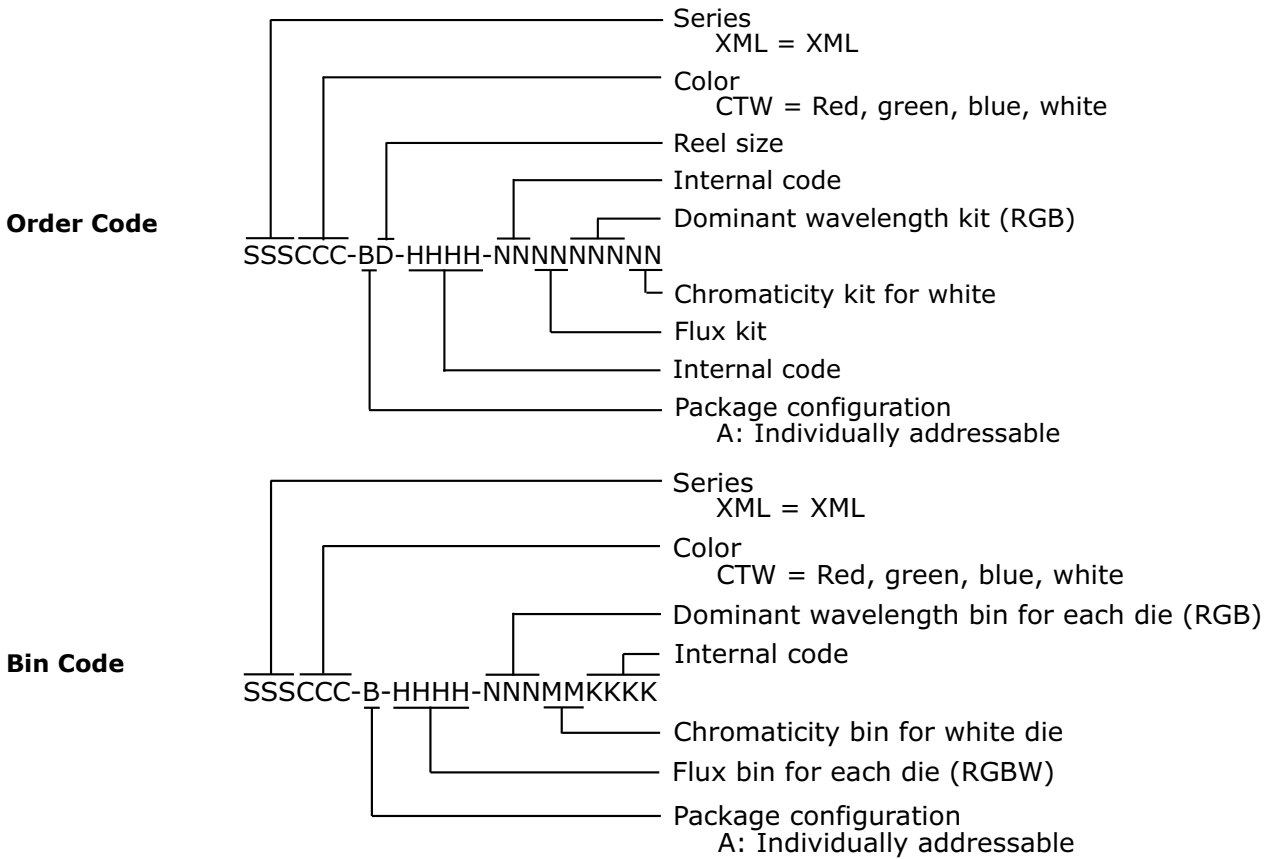

PERFORMANCE GROUPS – BRIGHTNESS

Each LED die in the XLamp XM-L Color LED is tested individually for luminous flux and placed into one of the following luminous-flux groups.

Color	Group Code	Min. Luminous Flux (lm) @ 350 mA	Max. Luminous Flux (lm) @ 350 mA
Red	M	45.7	87.4
	N	87.4	114
Green	N	87.4	114
	P	114	148
Blue	F	13.9	39.8
White	2	80	100
	3	100	120
	4	120	140

- Flux and chromaticity are measured with each LED die connected to independent drive circuits at 350 mA.

PERFORMANCE GROUPS – CHROMATICITY ($I_f = 350$ mA PER LED DIE)

The white LED die in the XLamp XM-L Color LED is individually tested for chromaticity at 350 mA and placed into one of the regions defined by the bounding coordinates shown below.

Region	x	y	Region	x	y
WM	.295	.297	WC	.316	.332
	.308	.311		.317	.319
	.310	.300		.308	.311
	.298	.288		.306	.322
WB	.306	.322	WF	.314	.355
	.308	.311		.316	.332
	.295	.297		.306	.322
	.292	.306		.301	.342
WE	.301	.342	WD	.329	.345
	.306	.322		.329	.330
	.292	.306		.317	.319
	.287	.321		.316	.332
WN	.308	.311	WG	.329	.369
	.317	.319		.329	.345
	.318	.308		.316	.332
	.310	.300		.314	.355

Region	x	y	Region	x	y	Region	x	y	Region	x	y
5A	.3670	.3578	5B	.3702	.3722	5C	.3825	.3798	5D	.3783	.3646
	.3702	.3722		.3736	.3874		.3869	.3958		.3825	.3798
	.3825	.3798		.3869	.3958		.4006	.4044		.3950	.3875
	.3783	.3646		.3825	.3798		.3950	.3875		.3898	.3716

PERFORMANCE GROUPS – DOMINANT WAVELENGTH

The red, green and blue LED dies in the XLamp XM-L Color LED are tested individually for dominant wavelength (DWL) and sorted into one of the DWL bins defined below.

Color	DWL Group	Min. DWL @ 350 mA	Max. DWL @ 350 mA
Blue	K	450	455
	L	455	460
	M	460	465
Green	2	520	525
	3	525	530
	4	530	535
Red	A	620	630

STANDARD ORDER CODES AND BINS

The following tables list standard kit numbers and performance bins. Kit numbers completely describe an order code's color or chromaticity bins and luminous flux range.

XLamp XM-L Color LED Standard Order Codes				
Color	Minimum Luminous Flux (lm) @ 350 mA*		DWL / Chromaticity Bins	Kit Number
	Group	Flux (lm)		
Red	M	45.7	A	00C3AAAA1
Green	N	87.4	2, 3, 4	
Blue	F	13.9	K, L, M	
White	3	100	WC, WD, WF, WG, WB, WE, WM, WN	
Red	M	45.7	A	00C2AAAB1
Green	N	87.4	2, 3, 4	
Blue	F	13.9	K, L, M	
White	2	80	5A, 5B, 5C, 5D	

For other flux and chromaticity combinations, contact Cree or an authorized distributor.

- * Cree XLamp XM-L Color order codes specify only a minimum flux bin and not a maximum. Cree may ship reels in flux bins higher than the minimum specified by the order code without advance notice. Shipments will always adhere to the chromaticity or DWL bin restrictions specified by the order code.

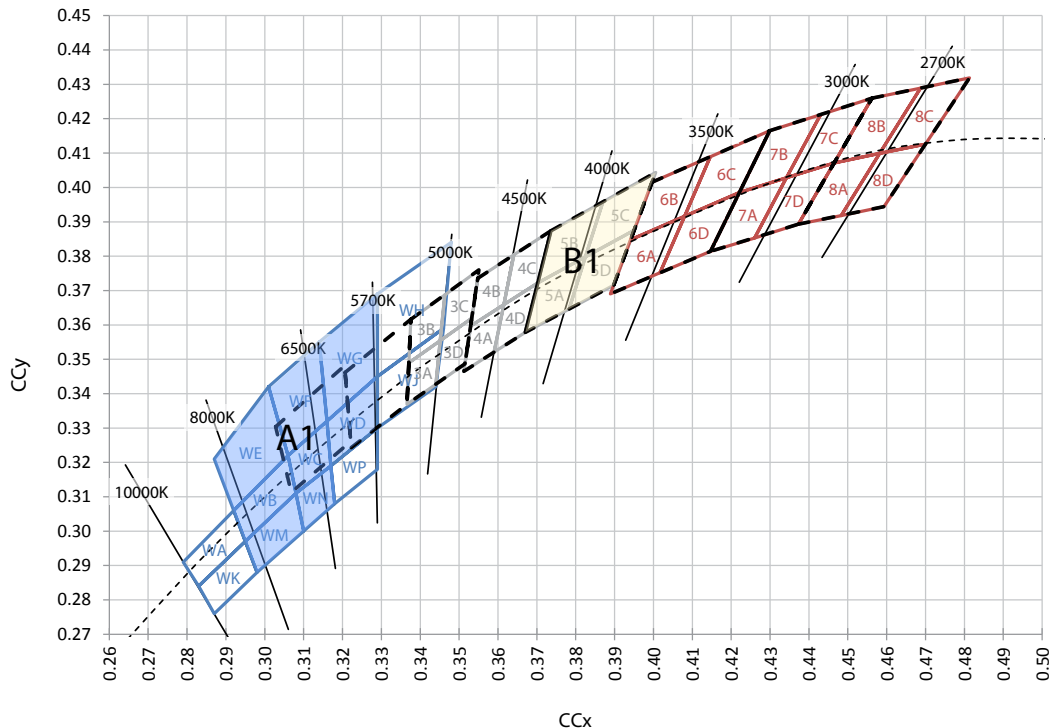

REFLOW SOLDERING CHARACTERISTICS

In testing, Cree has found XLamp XM-L Color LEDs to be compatible with JEDEC J-STD-020C, using the parameters listed below. As a general guideline, Cree recommends that users follow the recommended soldering profile provided by the manufacturer of solder paste used.

Note that this general guideline may not apply to all PCB designs and configurations of reflow soldering equipment.



IPC/JEDEC J-STD-020C

Profile Feature	Lead-Based Solder	Lead-Free Solder
Average Ramp-Up Rate ($T_{s_{max}}$ to T_p)	3 °C/second max.	3 °C/second max.
Preheat: Temperature Min ($T_{s_{min}}$)	100 °C	150 °C
Preheat: Temperature Max ($T_{s_{max}}$)	150 °C	200 °C
Preheat: Time ($t_{s_{min}}$ to $t_{s_{max}}$)	60-120 seconds	60-180 seconds
Time Maintained Above: Temperature (T_L)	183 °C	217 °C
Time Maintained Above: Time (t_L)	60-150 seconds	60-150 seconds
Peak/Classification Temperature (T_p)	215 °C	260 °C
Time Within 5 °C of Actual Peak Temperature (t_p)	10-30 seconds	20-40 seconds
Ramp-Down Rate	6 °C/second max.	6 °C/second max.
Time 25 °C to Peak Temperature	6 minutes max.	8 minutes max.

Note: All temperatures refer to the topside of the package, measured on the package body surface.

MECHANICAL DIMENSIONS

All measurements are $\pm .13$ mm unless otherwise indicated.

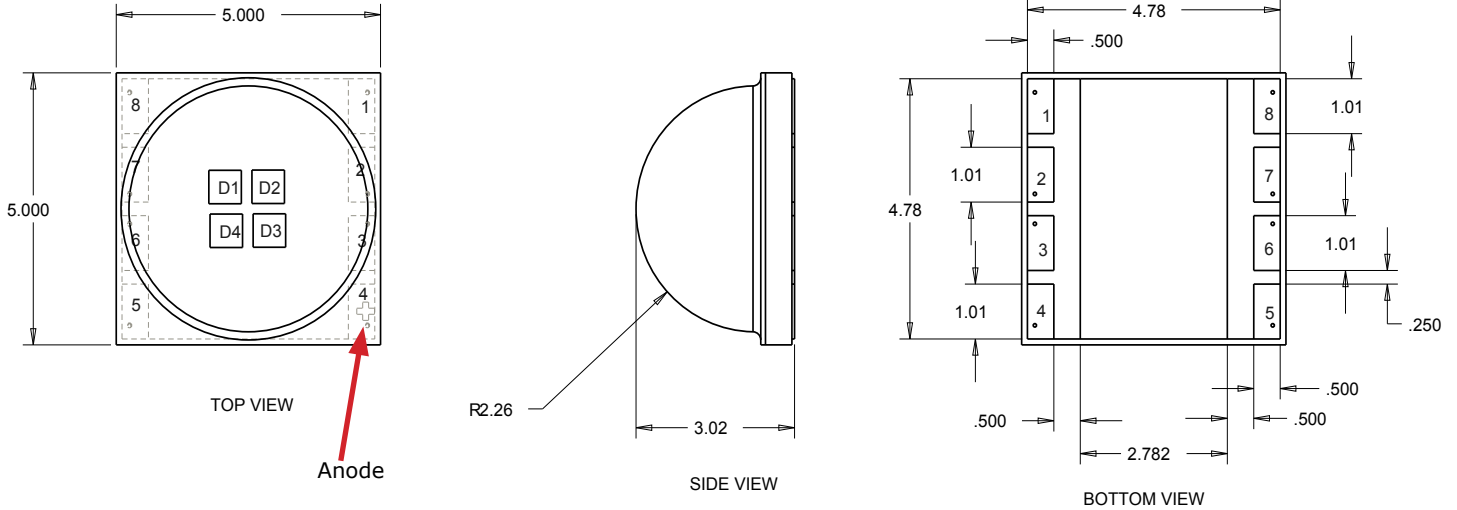

COLOR
 D1: RED
 D2: GREEN
 D3: BLUE
 D4: WHITE

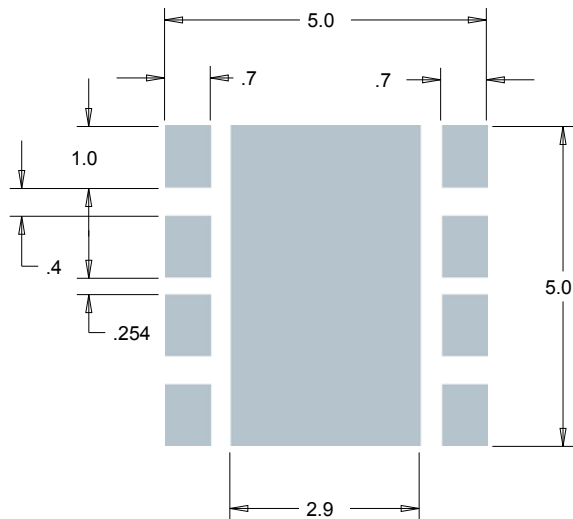
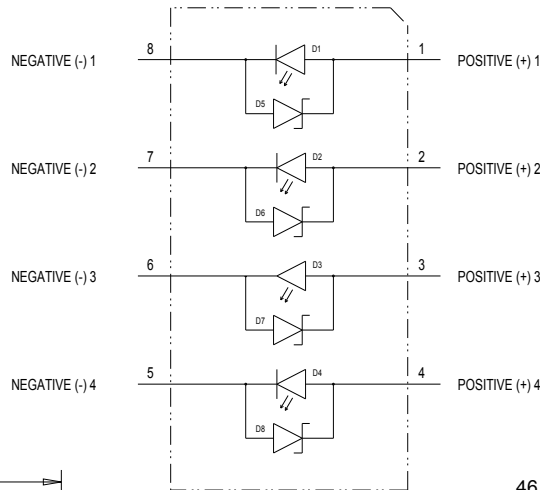

Recommended PCB Solder Pad

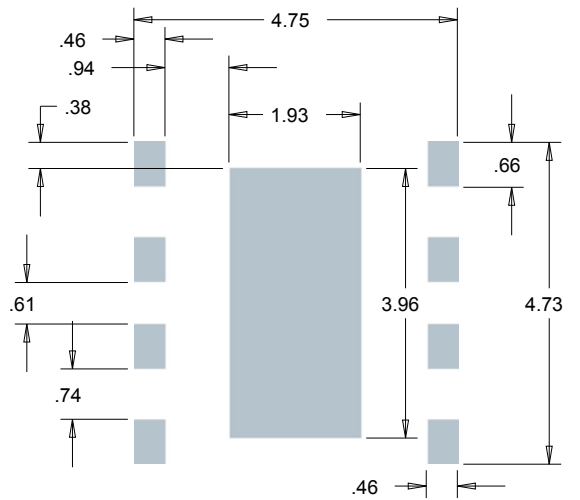

Recommended Stencil Pattern (Shaded Area Is Open)

TAPE AND REEL

All Cree carrier tapes conform to EIA-481D, Automated Component Handling Systems Standard.

All dimensions in mm.

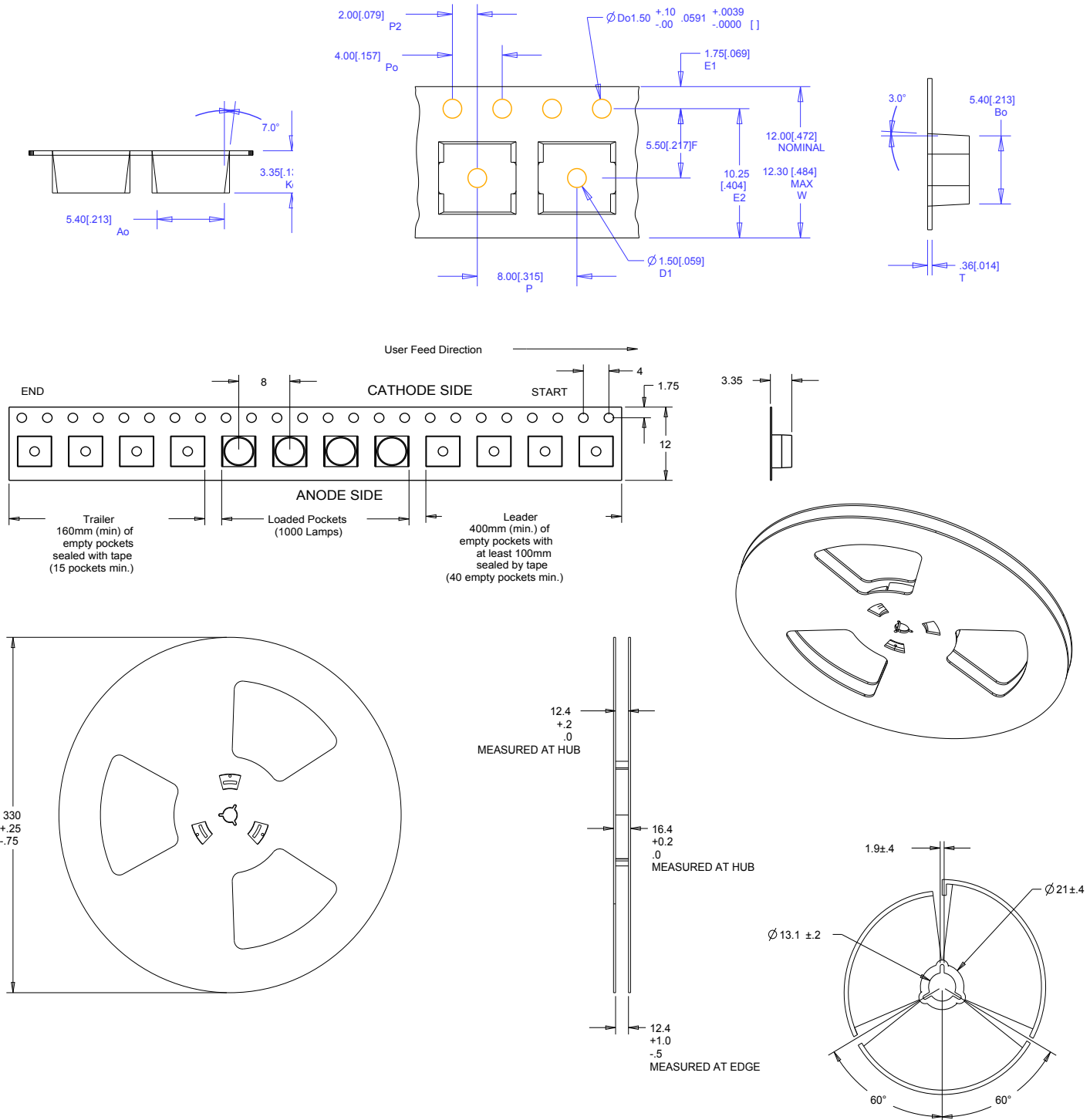

PACKAGING

Unpackaged Reel

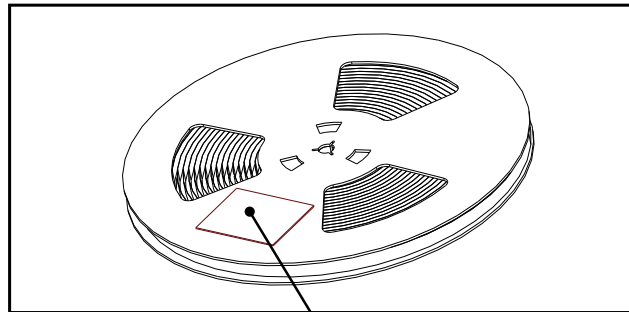

Label with Cree Bin Code, Qty, Reel ID

Packaged Reel

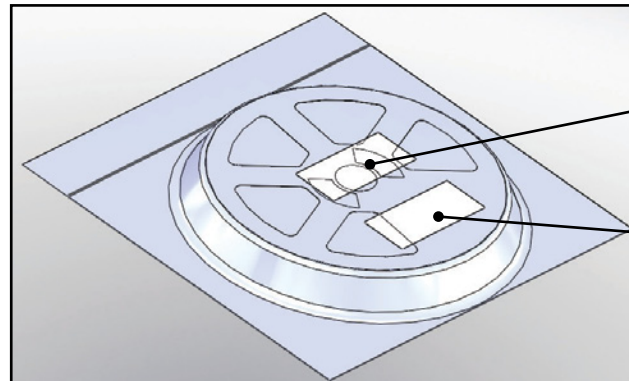

Label with Cree Order Code, Qty, Reel ID, PO #

Label with Cree Bin Code, Qty, Reel ID

Boxed Reel

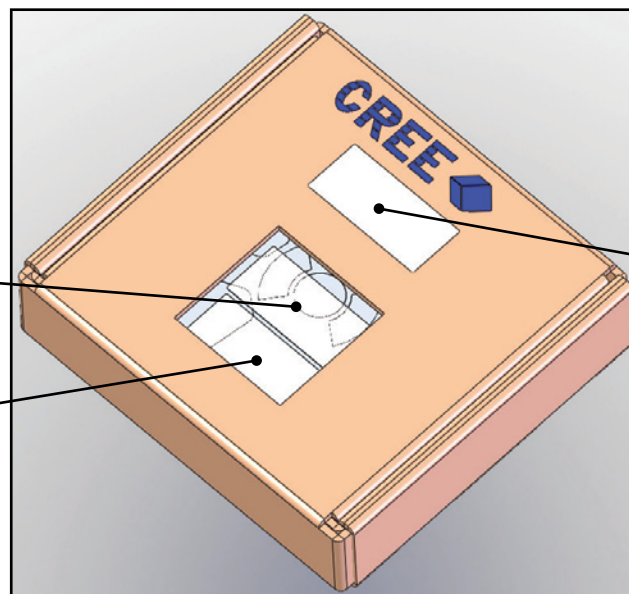

Label with Cree Order Code, Qty, Reel ID, PO #

Label with Cree Bin Code, Qty, Reel ID

Patent Label



Стандарт Электрон Связь

Мы молодая и активно развивающаяся компания в области поставок электронных компонентов. Мы поставляем электронные компоненты отечественного и импортного производства напрямую от производителей и с крупнейших складов мира.

Благодаря сотрудничеству с мировыми поставщиками мы осуществляем комплексные и плановые поставки широчайшего спектра электронных компонентов.

Собственная эффективная логистика и склад в обеспечивает надежную поставку продукции в точно указанные сроки по всей России.

Мы осуществляем техническую поддержку нашим клиентам и предпродажную проверку качества продукции. На все поставляемые продукты мы предоставляем гарантию .

Осуществляем поставки продукции под контролем ВП МО РФ на предприятия военно-промышленного комплекса России , а также работаем в рамках 275 ФЗ с открытием отдельных счетов в уполномоченном банке. Система менеджмента качества компании соответствует требованиям ГОСТ ISO 9001.

Минимальные сроки поставки, гибкие цены, неограниченный ассортимент и индивидуальный подход к клиентам являются основой для выстраивания долгосрочного и эффективного сотрудничества с предприятиями радиоэлектронной промышленности, предприятиями ВПК и научно-исследовательскими институтами России.

С нами вы становитесь еще успешнее!

Наши контакты:

Телефон: +7 812 627 14 35

Электронная почта: sales@st-electron.ru

Адрес: 198099, Санкт-Петербург,
Промышленная ул, дом № 19, литера Н,
помещение 100-Н Офис 331