

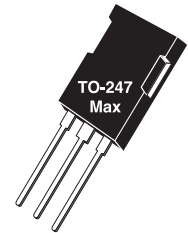

Field Stop IGBT

Utilizing the latest Field Stop and Trench Gate technologies, these IGBT's have ultra low $V_{CE(ON)}$ and are ideal for low frequency applications that require absolute minimum conduction loss. Easy paralleling is a result of very tight parameter distribution and a slightly positive $V_{CE(ON)}$ temperature coefficient. A built-in gate resistor ensures extremely reliable operation, even in the event of a short circuit fault. Low gate charge simplifies gate drive design and minimizes losses.



- 1200V Field Stop
- Trench Gate: Low $V_{CE(ON)}$
- Easy Paralleling
- Integrated Gate Resistor :Low EMI, High Reliability
- RoHS Compliant 

Applications: Welding, Inductive Heating, Solar Inverters, SMPS, Motor drives, UPS

Maximum Ratings

All Ratings: $T_c = 25^\circ C$ unless otherwise specified.

| Symbol | Parameter | Ratings | Unit |
|----------------|---|-------------|------------|
| V_{CES} | Collector-Emitter Voltage | 600 | Volts |
| V_{GE} | Gate-Emitter Voltage | ± 20 | |
| I_{C1} | Continuous Collector Current @ $T_c = 25^\circ C$ | 283 | Amps |
| I_{C2} | Continuous Collector Current @ $T_c = 110^\circ C$ | 158 | |
| I_{CM} | Pulsed Collector Current ^① | 600 | |
| SSOA | Switching Safe Operating Area @ $T_j = 175^\circ C$ | 600A @ 600V | |
| P_D | Total Power Dissipation | 682 | Watts |
| T_J, T_{STG} | Operating and Storage Junction Temperature Range | -55 to 175 | $^\circ C$ |
| T_L | Max. Lead Temp. for Soldering: 0.063" from Case for 10 Sec. | 300 | |

Static Electrical Characteristics

| Symbol | Characteristic / Test Conditions | Min | Typ | Max | Unit |
|---------------|--|------|------|------|----------|
| $V_{(BR)CES}$ | Collector-Emitter Breakdown Voltage ($V_{GE} = 0V, I_C = 4mA$) | 600 | - | - | Volts |
| $V_{GE(TH)}$ | Gate Threshold Voltage ($V_{CE} = V_{GE}, I_C = 3.2mA, T_j = 25^\circ C$) | 5.0 | 5.8 | 6.5 | |
| $V_{CE(ON)}$ | Collector Emitter On Voltage ($V_{GE} = 15V, I_C = 200A, T_j = 25^\circ C$) | 1.05 | 1.45 | 1.85 | |
| | Collector Emitter On Voltage ($V_{GE} = 15V, I_C = 200A, T_j = 125^\circ C$) | - | 1.65 | - | |
| I_{CES} | Collector Cut-off Current ($V_{CE} = 600V, V_{GE} = 0V, T_j = 25^\circ C$) ^② | - | - | 25 | μA |
| | Collector Cut-off Current ($V_{CE} = 600V, V_{GE} = 0V, T_j = 125^\circ C$) ^② | - | - | 1000 | |
| I_{GES} | Gate-Emitter Leakage Current ($V_{GE} = \pm 20V$) | - | - | 600 | nA |
| $R_{G(int)}$ | Integrated Gate Resistor | - | 2 | - | Ω |

 CAUTION: These Devices are Sensitive to Electrostatic Discharge. Proper Handling Procedures Should Be Followed.

Dynamic Characteristics

APT200GN60B2G

| Symbol | Characteristic | Test Conditions | Min | Typ | Max | Unit |
|--------------|--|---|-----|-------|-----|------|
| C_{ies} | Input Capacitance | $V_{GE} = 0V, V_{CE} = 25V$ $f = 1MHz$ | - | 14100 | - | pF |
| C_{oes} | Output Capacitance | | - | 461 | - | |
| C_{res} | Reverse Transfer Capacitance | | - | 393 | - | |
| V_{GEP} | Gate-to-Emitter Plateau Voltage | Gate Charge $V_{GE} = 15V$ $V_{CE} = 300V$ $I_C = 100A$ | - | 8.2 | - | V |
| Q_g | Total Gate Charge | | - | 1180 | - | nC |
| Q_{ge} | Gate-Emitter Charge | | - | 85 | - | |
| Q_{gc} | Gate-Collector Charge | | - | 660 | - | |
| SSOA | Switching Safe Operating Area | $T_J = 150^\circ C, R_G = 1.0\Omega^{(2)}, V_{GE} = 15V,$ $L = 100\mu H, V_{CE} = 600V$ | 600 | | | A |
| $t_{d(on)}$ | Turn-On Delay Time | Inductive Switching ($25^\circ C$) $V_{CC} = 400V$ $V_{GE} = 15V$ $I_C = 200A$ $R_G = 1.0\Omega$ $T_J = +25^\circ C$ | - | 50 | - | ns |
| t_r | Current Rise Time | | - | 80 | - | |
| $t_{d(off)}$ | Turn-Off Delay Time | | - | 560 | - | |
| t_f | Current Fall Time | | - | 100 | - | mJ |
| E_{on1} | Turn-On Switching Energy ⁽⁴⁾ | | - | 13 | - | |
| E_{on2} | Turn-On Switching Energy ⁽⁵⁾ | | - | 15 | - | |
| E_{off} | Turn-Off Switching Energy ⁽⁶⁾ | - | 11 | - | | |
| $t_{d(on)}$ | Turn-On Delay Time | Inductive Switching ($125^\circ C$) $V_{CC} = 400V$ $V_{GE} = 15V$ $I_C = 200A$ $R_G = 1.0\Omega$ $T_J = +125^\circ C$ | - | 50 | - | ns |
| t_r | Current Rise Time | | - | 80 | - | |
| $t_{d(off)}$ | Turn-Off Delay Time | | - | 620 | - | |
| t_f | Current Fall Time | | - | 70 | - | mJ |
| E_{on1} | Turn-On Switching Energy ⁽⁴⁾ | | - | 14 | - | |
| E_{on2} | Turn-On Switching Energy ⁽⁵⁾ | | - | 16 | - | |
| E_{off} | Turn-Off Switching Energy ⁽⁶⁾ | - | 10 | - | | |

Thermal and Mechanical Characteristics

| Symbol | Characteristic / Test Conditions | Min | Typ | Max | Unit |
|-----------------|----------------------------------|-----|-----|------|--------------|
| $R_{\theta JC}$ | Junction to Case (IGBT) | - | - | 0.13 | $^\circ C/W$ |
| $R_{\theta JC}$ | Junction to Case (DIODE) | - | - | N/A | |
| W_T | Package Weight | - | 6.1 | - | gm |

① Repetitive Rating: Pulse width limited by maximum junction temperature.

② For Combi devices, I_{ces} includes both IGBT and FRED leakages

③ See MIL-STD-750 Method 3471.

④ E_{on1} is the clamped inductive turn-on energy of the IGBT only, without the effect of a commutating diode reverse recovery current adding to the IGBT turn-on loss. Tested in inductive switching test circuit shown in figure 21, but with a Silicon Carbide diode.

⑤ E_{on2} is the clamped inductive turn-on energy that includes a commutating diode reverse recovery current in the IGBT turn-on switching loss. (See Figures 21, 22.)

⑥ E_{off} is the clamped inductive turn-off energy measured in accordance with JEDEC standard JESD24-1. (See Figures 21, 23.)

⑦ R_G is external gate resistance not including gate driver impedance.

Microsemi reserves the right to change, without notice, the specifications and information contained herein.

Typical Performance Curves

APT200GN60B2G

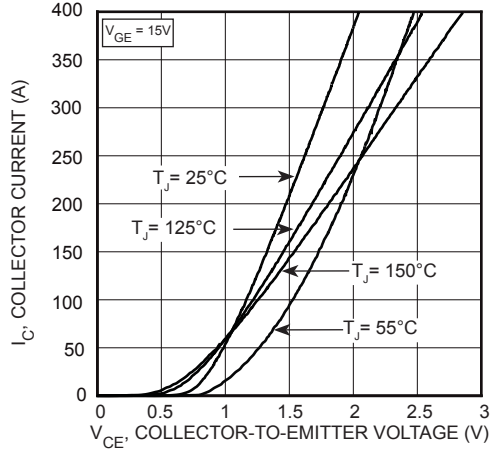

FIGURE 1, Output Characteristics ($T_J = 25^\circ\text{C}$)

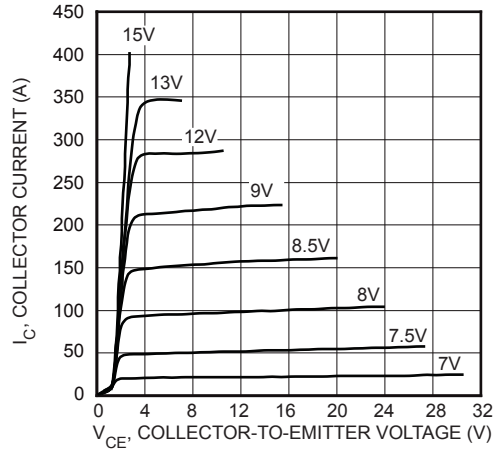

FIGURE 2, Output Characteristics ($T_J = 25^\circ\text{C}$)

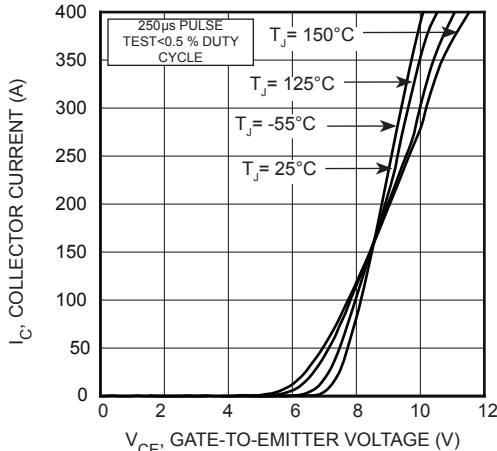

FIGURE 3, Transfer Characteristics

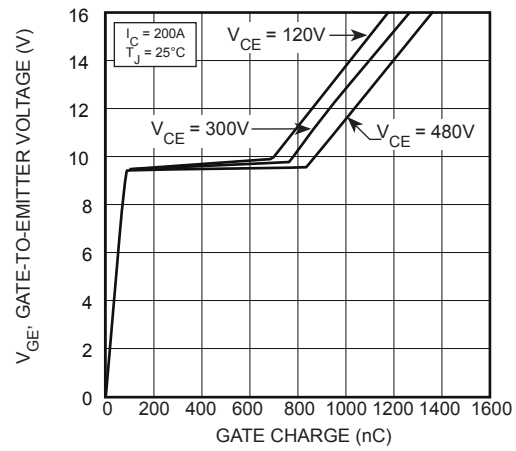

FIGURE 4, Gate charge

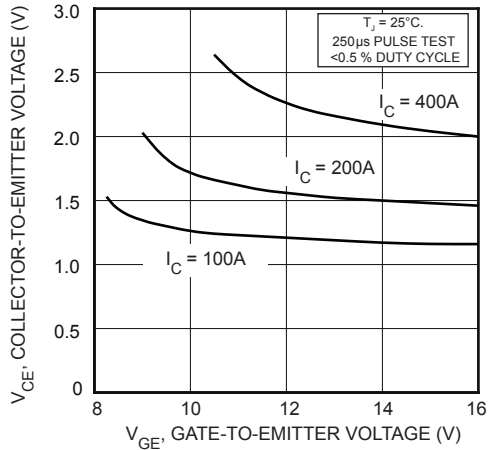

FIGURE 5, On State Voltage vs Gate-to-Emitter Voltage

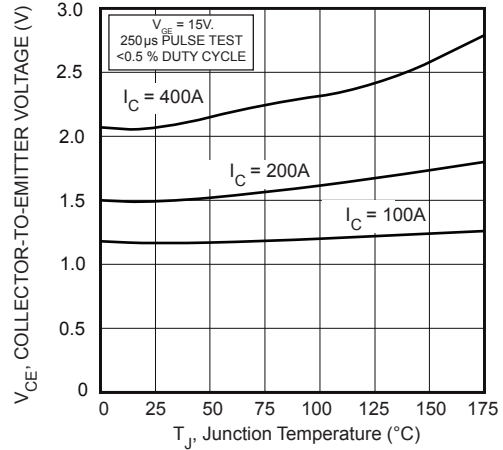

FIGURE 6, On State Voltage vs Junction Temperature

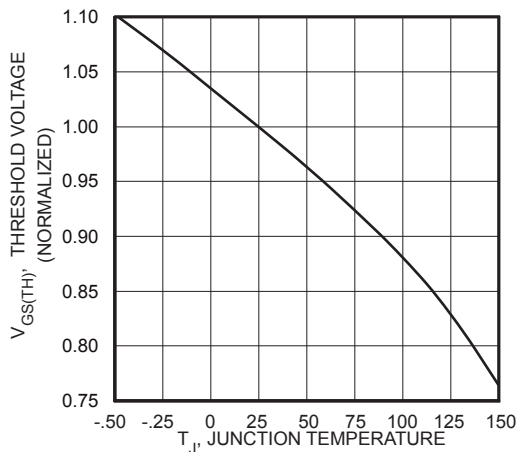

FIGURE 7, Threshold Voltage vs Junction Temperature

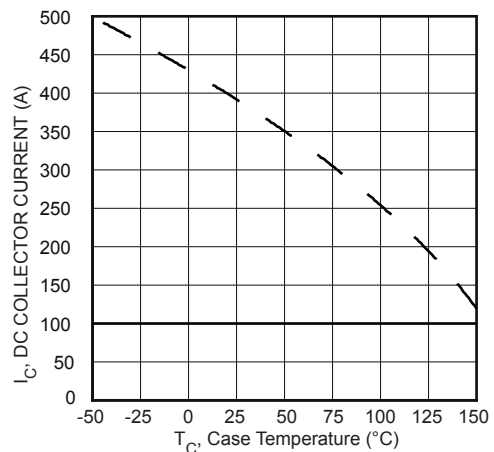

FIGURE 8, DC Collector Current vs Case Temperature

Typical Performance Curves

APT200GN60B2G

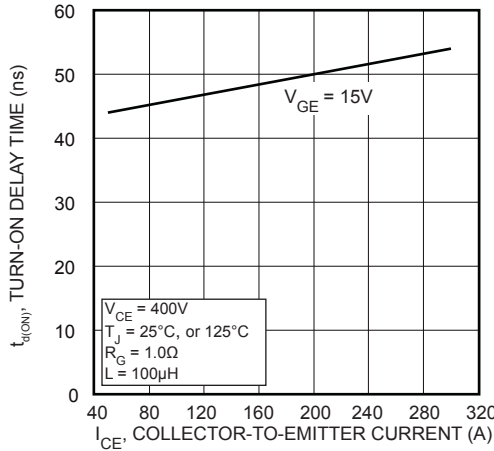

FIGURE 9, Turn-On Delay Time vs Collector Current

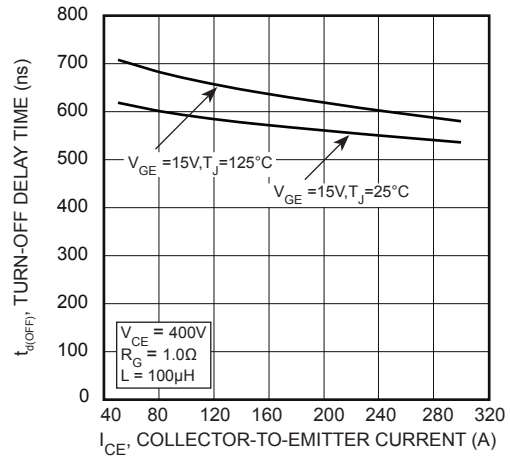

FIGURE 10, Turn-Off Delay Time vs Collector Current

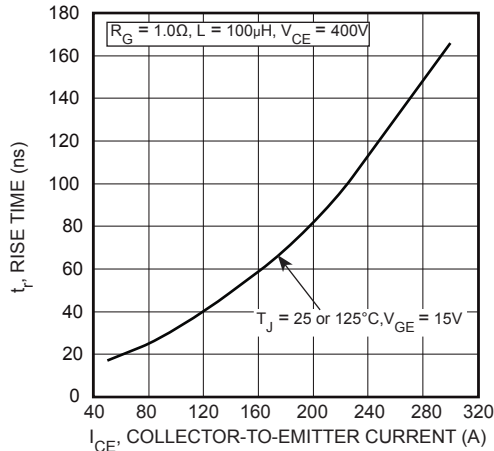

FIGURE 11, Current Rise Time vs Collector Current

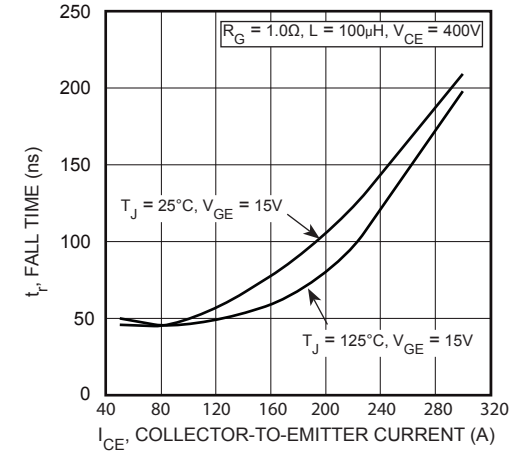

FIGURE 12, Current Fall Time vs Collector Current

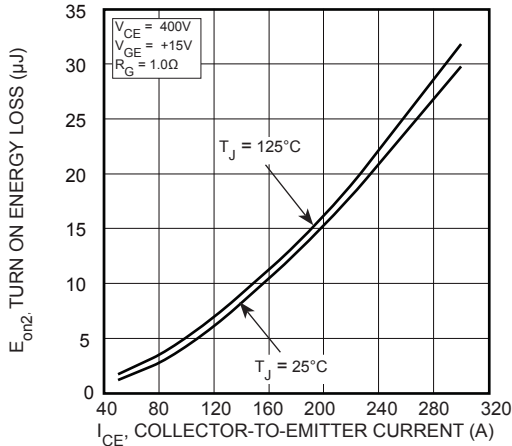

FIGURE 13, Turn-On Energy Loss vs Collector Current

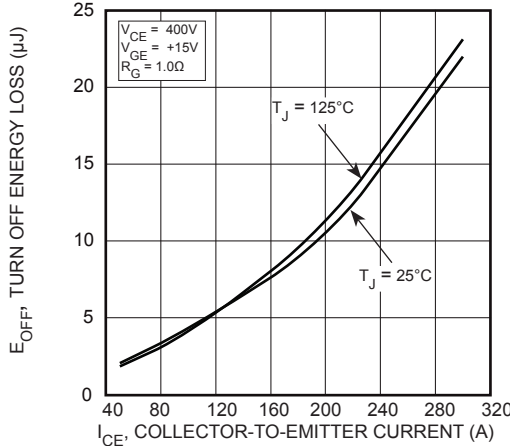

FIGURE 14, Turn-Off Energy Loss vs Collector Current

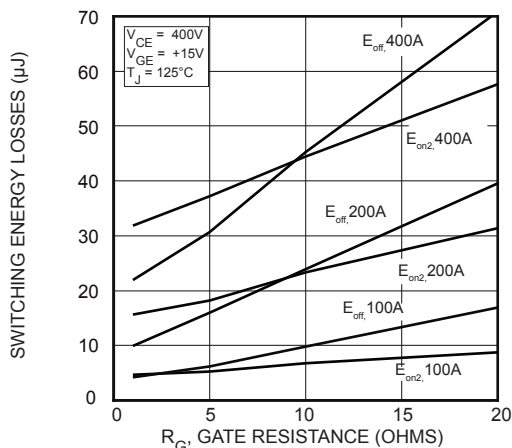

FIGURE 15, Switching Energy Losses vs Gate Resistance

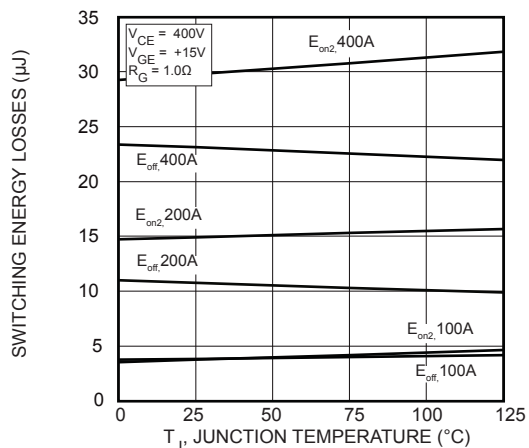

FIGURE 16, Switching Energy Losses vs Junction Temperature

Typical Performance Curves

APT200GN60B2G

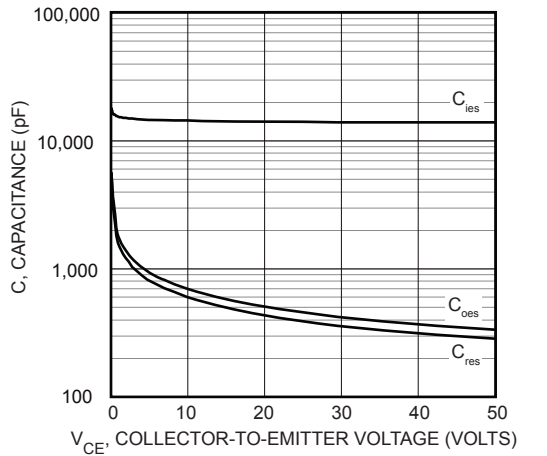

FIGURE 17, Capacitance vs Collector-To-Emitter Voltage

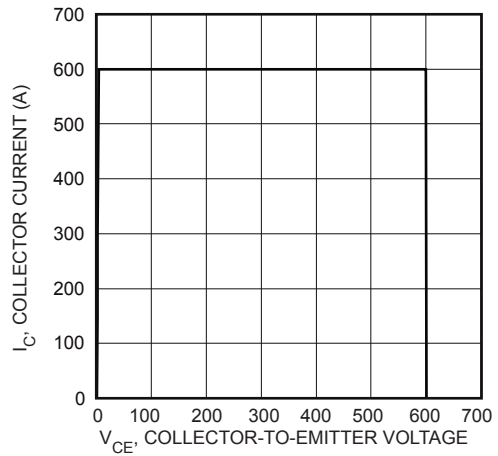

FIGURE 18, Minimum Switching Safe Operating Area

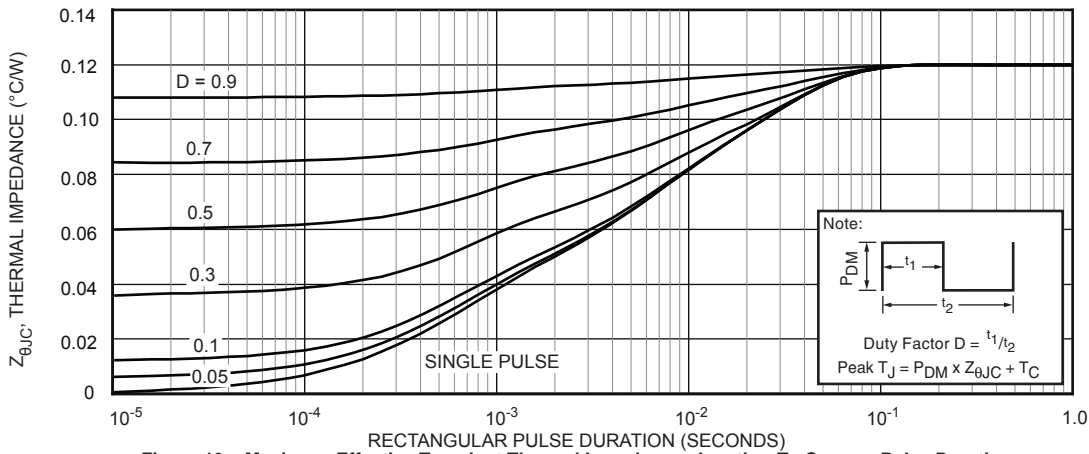

Figure 19a, Maximum Effective Transient Thermal Impedance, Junction-To-Case vs Pulse Duration

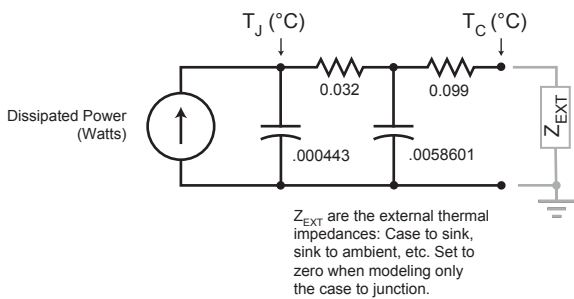

FIGURE 19b, TRANSIENT THERMAL IMPEDANCE MODEL

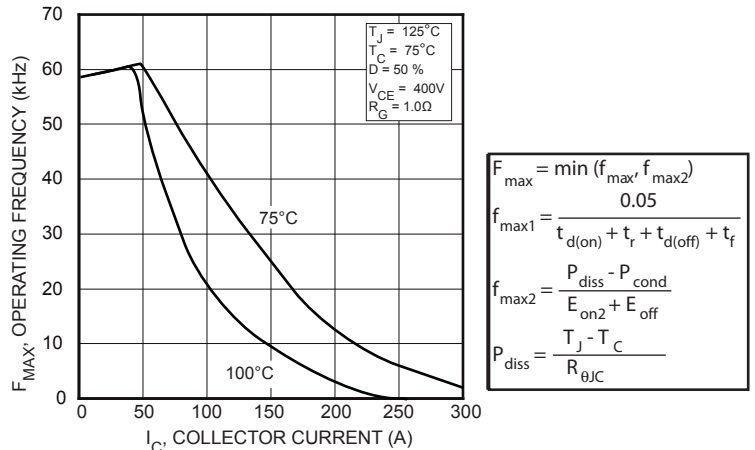

Figure 20, Operating Frequency vs Collector Current

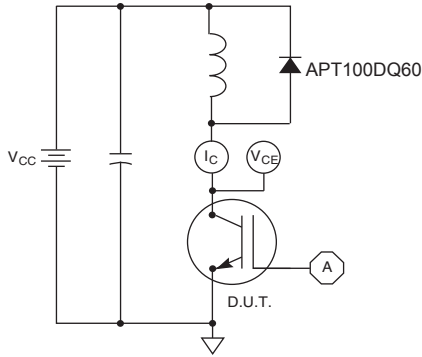

Figure 21, Inductive Switching Test Circuit

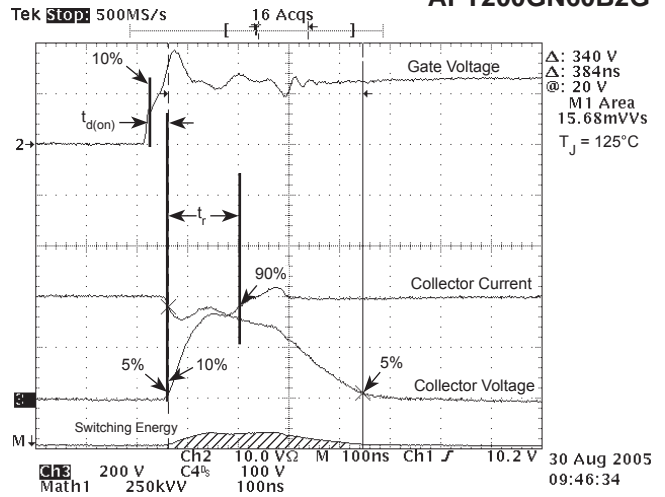

Figure 22, Turn-on Switching Waveforms and Definitions

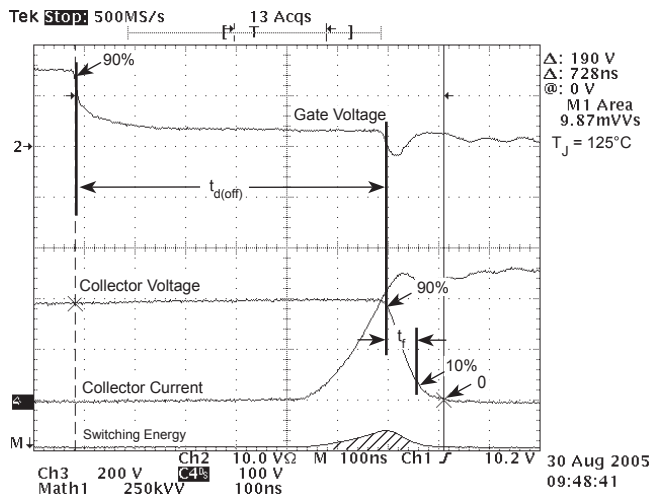
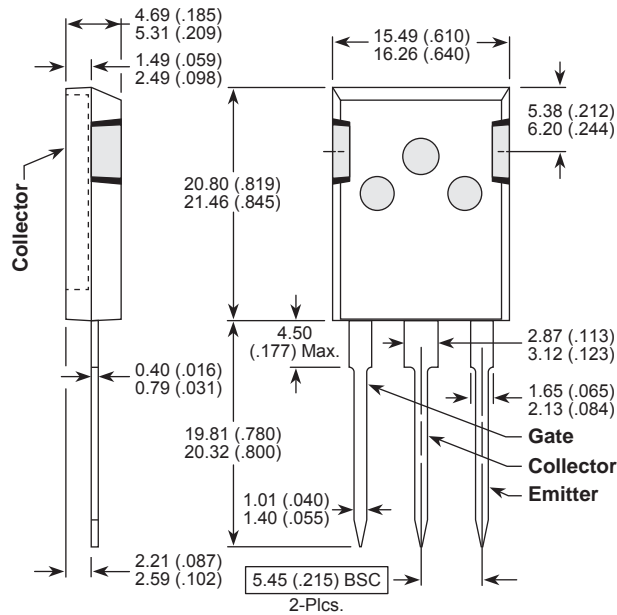

Figure 23, Turn-off Switching Waveforms and Definitions

T-MAX® Package Outline



Dimensions in Millimeters and (Inches)

Microsemi's products are covered by one or more of U.S. patents 4,895,810 5,045,903 5,089,434 5,182,234 5,019,522 5,262,336 6,503,786 5,256,583 4,748,103 5,283,202 5,231,474 5,434,095 5,528,058 6,939,743, 7,352,045 5,283,201 5,801,417 5,648,283 7,196,634 6,664,594 7,157,886 6,939,743 7,342,262 and foreign patents. US and Foreign patents pending. All Rights Reserved.



**Стандарт
Электрон
Связь**

Мы молодая и активно развивающаяся компания в области поставок электронных компонентов. Мы поставляем электронные компоненты отечественного и импортного производства напрямую от производителей и с крупнейших складов мира.

Благодаря сотрудничеству с мировыми поставщиками мы осуществляем комплексные и плановые поставки широчайшего спектра электронных компонентов.

Собственная эффективная логистика и склад в обеспечивает надежную поставку продукции в точно указанные сроки по всей России.

Мы осуществляем техническую поддержку нашим клиентам и предпродажную проверку качества продукции. На все поставляемые продукты мы предоставляем гарантию .

Осуществляем поставки продукции под контролем ВП МО РФ на предприятия военно-промышленного комплекса России , а также работаем в рамках 275 ФЗ с открытием отдельных счетов в уполномоченном банке. Система менеджмента качества компании соответствует требованиям ГОСТ ISO 9001.

Минимальные сроки поставки, гибкие цены, неограниченный ассортимент и индивидуальный подход к клиентам являются основой для выстраивания долгосрочного и эффективного сотрудничества с предприятиями радиоэлектронной промышленности, предприятиями ВПК и научно-исследовательскими институтами России.

С нами вы становитесь еще успешнее!

Наши контакты:

Телефон: +7 812 627 14 35

Электронная почта: sales@st-electron.ru

Адрес: 198099, Санкт-Петербург,
Промышленная ул, дом № 19, литера Н,
помещение 100-Н Офис 331