

## Features

- 1-of-8 bidirectional translating switch
- I2C-bus interface logic
- Operating power supply voltage from 1.65V to 5.5V
- Allows voltage level translation between 1.2V, 1.8V, 2.5 V, 3.3 V and 5 V buses
- Low standby current
- Low Ron switches
- Active LOW reset input
- Channel selection via I2C bus
- Power-up with all switches channels deselected
- Capacitance isolation when channel disabled
- No glitch on power-up
- Supports hot insertion
- 5 V tolerant inputs
- 0 Hz to 400 kHz clock frequency
- ESD protection exceeds 8000 V HBM per JESD22-A114, and 1000 V CDM per JESD22-C101
- Latch-up testing is done to JEDEC Standard JESD78 which exceeds 100 mA
- Packages offered: TSSOP-24L, TQFN-24ZD

## Pin Configuration

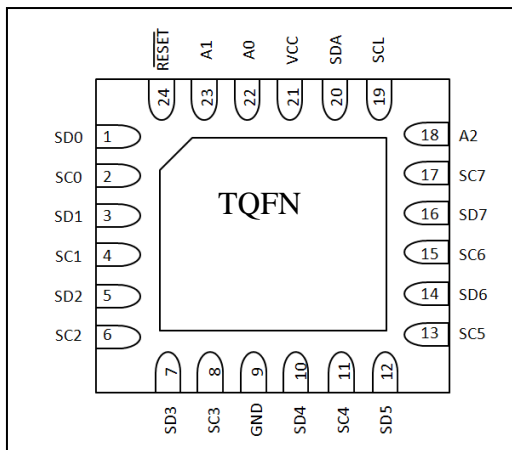
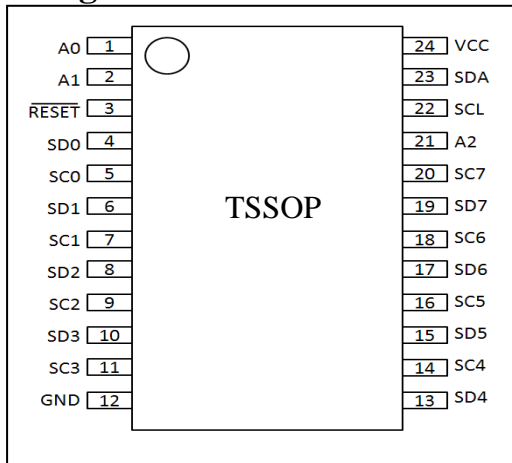

## 8 Channel I2C bus Switch with Reset Description

The PI4MSD5V9548A is an octal bidirectional translating switch controlled via the I2C bus. The SCL/SDA upstream pair fans out to eight downstream pairs, or channels. Any individual SCx/SDx channel or combination of channels can be selected, determined by the contents of the programmable control register.

An active LOW reset input allows the PI4MSD5V9548A to recover from a situation where one of the downstream buses is stuck in a LOW state. Pulling the RESET pin LOW resets the I2C bus state machine and causes all the channels to be deselected as does the internal Power-on reset function.

The pass gates of the switches are constructed such that the VCC pin can be used to limit the maximum high voltage which will be passed by the PI4MSD5V9548A. This allows the use of different bus voltages on each pair, so that 1.2V, 1.8 V or 2.5 V or 3.3 V parts can communicate with 5 V parts without any additional protection. External pull-up resistors pull the bus up to the desired voltage level for each channel. All I/O pins are 5 V tolerant.

## Pin Description

Pin No. (TSSOP, SOIC)	Pin No. (TQFN)	Pin Name	Type	Description
1	22	A0	I	address input 0
2	23	A1	I	address input 1
3	24	RESET	I	active LOW reset input
4	1	SD0	I/O	serial data 0
5	2	SC0	I/O	serial clock 0
6	3	SD1	I/O	serial data 1
7	4	SC1	I/O	serial clock 1
8	5	SD2	I/O	serial data 2
9	6	SC2	I/O	serial clock 2
10	7	SD3	I/O	serial data 3
11	8	SC3	I/O	serial clock 3
12	9	GND	Ground	supply ground
13	10	SD4	I/O	serial data 4
14	11	SC4	I/O	serial clock 4
15	12	SD5	I/O	serial data 5
16	13	SC5	I/O	serial clock 5
17	14	SD6	I/O	serial data 6
18	15	SC6	I/O	serial clock 6
19	16	SD7	I/O	serial data 7
20	17	SC7	I/O	serial clock 7
21	18	A2	I	address input 2
22	19	SCL	I/O	serial clock line
23	20	SDA	I/O	serial data line
24	21	VCC	Power	supply voltage

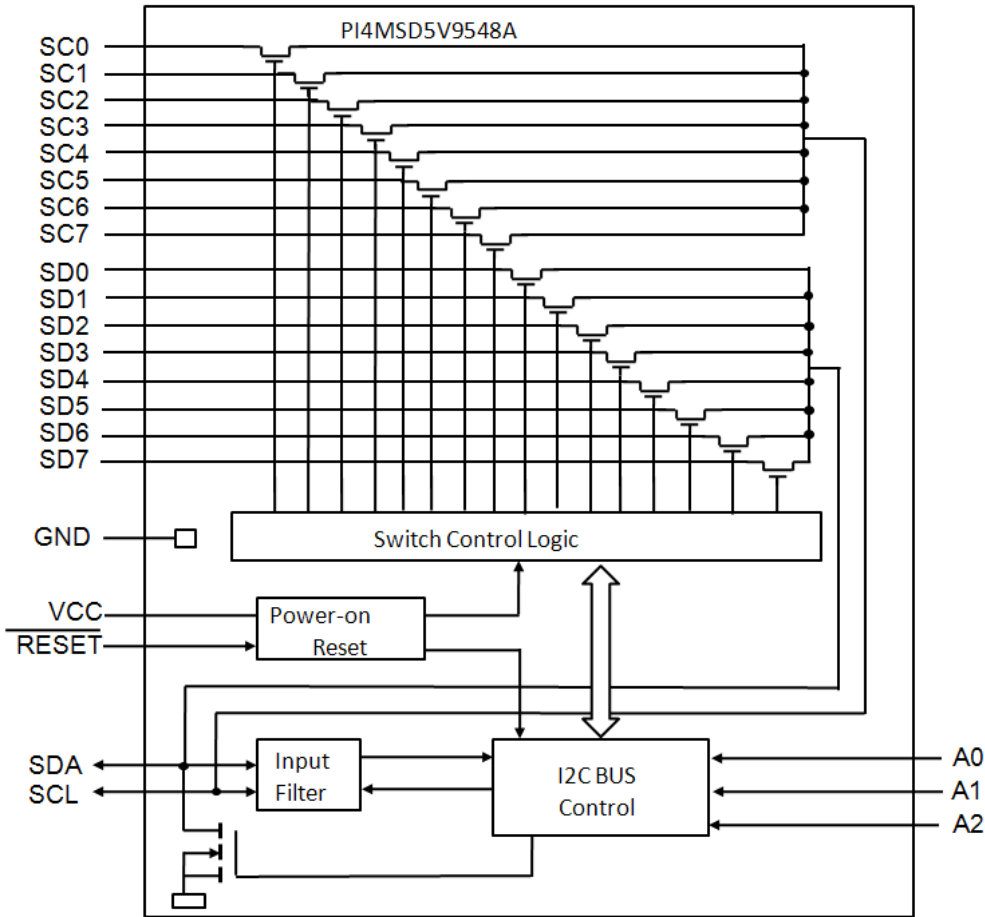
**Block Diagram**

**Figure 1: Block Diagram**
**Maximum Ratings**

Storage Temperature .....	-55 °C to +125 °C
Supply Voltage port B .....	-0.5V to +6.0V
Supply Voltage port A .....	-0.5V to +6.0V
DC Input Voltage .....	-0.5V to +6.0V
Control Input Voltage (EN).....	-0.5V to +6.0V
Total power dissipation <sup>(1)</sup> .....	100mW
Input current(EN,VCC,GND).....	50mA
ESD: HBM Mode .....	8000V

**Note:**

Stresses greater than those listed under MAXIMUM RATINGS may cause permanent damage to the device. This is a stress rating only and functional operation of the device at these or any other conditions above those indicated in the operational sections of this specification is not implied. Exposure to absolute maximum rating conditions for extended periods may affect reliability.

**Recommended operation conditions**

Symbol	Parameter	Min	Typ	Max	Unit
V <sub>CC</sub>	V <sub>CCA</sub> Positive DC Supply Voltage	1.65	-	5.5	V
V <sub>EN</sub>	Enable Control Pin Voltage	GND	-	5.5	V
V <sub>IO</sub>	I/O Pin Voltage	GND	-	5.5	V
Δt / ΔV	Input transition rise or fall time	-	-	10	ns/V
T <sub>A</sub>	Operating Temperature Range	-40	-	+85	°C

**DC Electrical Characteristics**

 Unless otherwise specified,  $-40^{\circ}\text{C} \leq T_A \leq 85^{\circ}\text{C}$ ,  $1.1\text{V} \leq V_{\text{CC}} \leq 3.6\text{V}$ 

Symbol	Parameter	Conditions	VCC	Min	Typ	Max	Unit
<b>Supply</b>							
VCC	Supply Voltage			1.65		5.5	V
ICC	supply current	operating mode; no load; $V_1 = V_{\text{CC}}$ or GND; $f_{\text{SCL}} = 100 \text{ kHz}$	3.6V to 5.5V		65	100	$\mu\text{A}$
			2.3V to 3.6V		20	50	$\mu\text{A}$
			1.65V to 2.3V		10	30	$\mu\text{A}$
Istb	standby current	standby mode; $V_{\text{CC}} = 3.6 \text{ V}$ ; no load; $V_1 = V_{\text{CC}}$ or GND; $f_{\text{SCL}} = 0 \text{ kHz}$	3.6V to 5.5V		0.3	1	$\mu\text{A}$
			2.3V to 3.6V		0.1	1	$\mu\text{A}$
			1.65V to 2.3V		0.1	1	$\mu\text{A}$
VPOR <sup>[1]</sup>	power-on reset voltage	no load; $V_1 = V_{\text{CC}}$ or GND	3.6V to 5.5V		1.3	1.5	V
<b>Input SCL; input/output SDA</b>							
V <sub>IL</sub>	LOW-level input voltage		1.65V to 5.5V	-0.5		+0.3VCC	V
V <sub>IH</sub>	HIGH-level input voltage		1.65V to 2V	0.75VCC		6	V
			2V to 5.5V	0.7VCC		6	V
I <sub>OL</sub>	LOW-level output current	$V_{\text{OL}} = 0.4 \text{ V}$	1.65V to 5.5V	3		-	mA
		$V_{\text{OL}} = 0.6 \text{ V}$	1.65V to 5.5V	6		-	mA
I <sub>IL</sub>	LOW-level input current	$V_1 = \text{GND}$	1.65V to 5.5V	-1		+1	$\mu\text{A}$
I <sub>IH</sub>	HIGH-level input current	$V_1 = V_{\text{CC}}$	1.65V to 5.5V	-1		+1	$\mu\text{A}$
C <sub>i</sub>	input capacitance	$V_1 = \text{GND}$	1.65V to 5.5V	-	15	21	pF
<b>Select inputs A0, A1, A2, Reset</b>							
V <sub>IL</sub>	LOW-level input voltage		1.65V to 5.5V	-0.5		+0.3VCC	V
V <sub>IH</sub>	HIGH-level input voltage		1.65V to 5.5V	0.7VCC		6	V
I <sub>IL</sub>	LOW-level input current	$V_1 = \text{GND}$	1.65V to 5.5V	-1		+1	$\mu\text{A}$
C <sub>i</sub>	input capacitance	$V_1 = \text{GND}$	1.65V to 5.5V		3	5	pF
<b>Pass Gate</b>							
Ron	ON-state resistance	$V_{\text{O}} = 0.4 \text{ V}$ ; $I_{\text{O}} = 15 \text{ mA}$	4.5 V to 5.5 V	4	9	24	$\Omega$
			3V to 3.6V	5	11	31	$\Omega$
		$V_{\text{O}} = 0.4 \text{ V}$ ; $I_{\text{O}} = 10 \text{ mA}$	2.3V to 2.7V	7	16	55	$\Omega$
			1.65V to 2V	9	20	70	$\Omega$
V <sub>pass</sub>	switch output voltage	$V_{\text{in}} = V_{\text{CC}}$ ; $I_{\text{out}} = -100 \mu\text{A}$	5V		3.6		V
			4.5 V to 5.5 V	2.8		4.5	V
			3.3V		2.2		V
			3V to 3.6V	1.6		2.8	V
			2.5V		1.5		V
			2.3V to 2.7V	1.1		2	V
			1.8V		0.9		V
			1.65V to 2V	0.54		1.3	V
I <sub>L</sub>	leakage current	$V_1 = V_{\text{CC}}$ or GND	1.65V to 5.5V	-1		+1	$\mu\text{A}$
C <sub>io</sub>	input/output capacitance	$V_1 = V_{\text{CC}}$ or GND	1.65V to 5.5V		3	5	pF

**Note:**

[1] VCC must be lowered to 0.2 V for at least 5 us in order to reset part.

### AC Electrical characteristics

Tamb = - 40 °C to +85 °C; unless otherwise specified.

Symbol	Parameter	Conditions	VCC	Min	Typ	Max	Unit
t <sub>PD</sub> <sup>[1]</sup>	propagation delay	from SDA to SDx, or SCL to SCx	1.65V to 5.5V			0.3	ns
<b>RESET</b>							
t <sub>w(rst)L</sub>	LOW-level reset time		1.65V to 5.5V	4			ns
t <sub>rst</sub>	reset time	SDA clear	1.65V to 5.5V	500			ns
t <sub>REC:STA</sub>	recovery time to START condition		1.65V to 5.5V	0			ns

Note

[1]Pass gate propagation delay is calculated from the 20 Ω typical Ron and the 15 pF load capacitance.

### I2C Interface Timing Requirements

Symbol	Parameter	STANDARD MODE I <sup>2</sup> C BUS		FAST MODE I <sup>2</sup> C BUS		UNIT
		MIN	MAX	MIN	MAX	
f <sub>scl</sub>	I2C clock frequency	0	100	0	400	kHz
t <sub>Low</sub>	I2C clock high time	4.7		1.3		μs
t <sub>High</sub>	I2C clock low time	4		0.6		μs
t <sub>SP</sub>	I2C spike time		50		50	ns
t <sub>SU:DAT</sub>	I2C serial-data setup time	250		100		ns
t <sub>HD:DAT</sub>	I2C serial-data hold time	0 <sup>[1]</sup>		0 <sup>[1]</sup>		μs
t <sub>r</sub>	I2C input rise time		1000		300	ns
t <sub>f</sub>	I2C input fall time		300		300	ns
t <sub>BUF</sub>	I2C bus free time between stop and start	4.7		1.3		μs
t <sub>SU:STA</sub>	I2C start or repeated start condition setup	4.7		0.6		μs
t <sub>HD:STA</sub>	I2C start or repeated start condition hold	4		0.6		μs
t <sub>SU:STO</sub>	I2C stop condition setup	4		0.6		μs
t <sub>VD:DAT</sub>	Valid-data time (high to low) <sup>[2]</sup> SCL low to SDA output low valid		1		1	μs
	Valid-data time (low to high) <sup>[2]</sup> SCL low to SDA output high valid		0.6		0.6	μs
t <sub>VD:ACK</sub>	Valid-data time of ACK condition ACK signal from SCL low to SDA output low		1		1	μs
C <sub>b</sub>	I2C bus capacitive load		400		400	pF

Notes:

[1] A device internally must provide a hold time of at least 300 ns for the SDA signal (referred to as the VIH min of the SCL signal), in order to bridge the undefined region of the falling edge of SCL.

[2] Data taken using a 1-kΩ pull up resistor and 50-pF load Notes

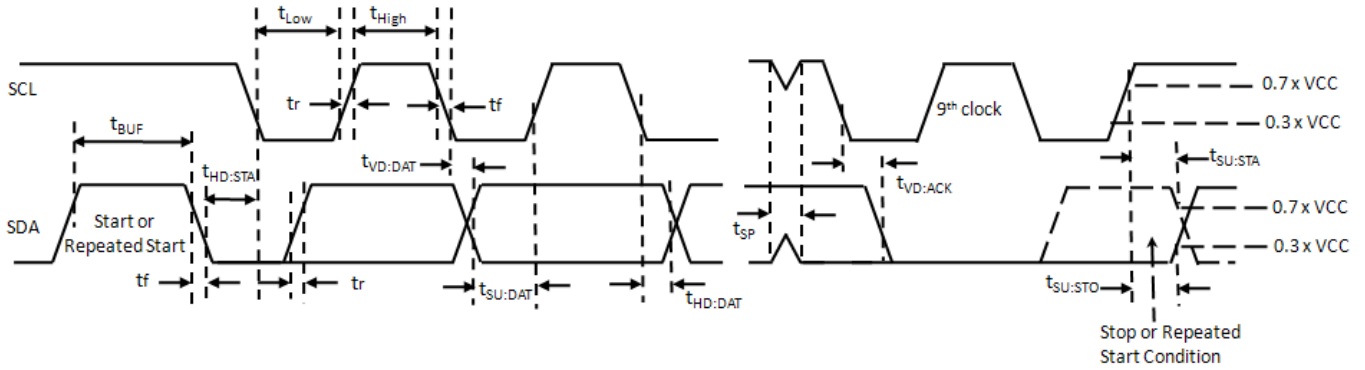

Figure 2. Definition of timing on the I2C-bus

### Application

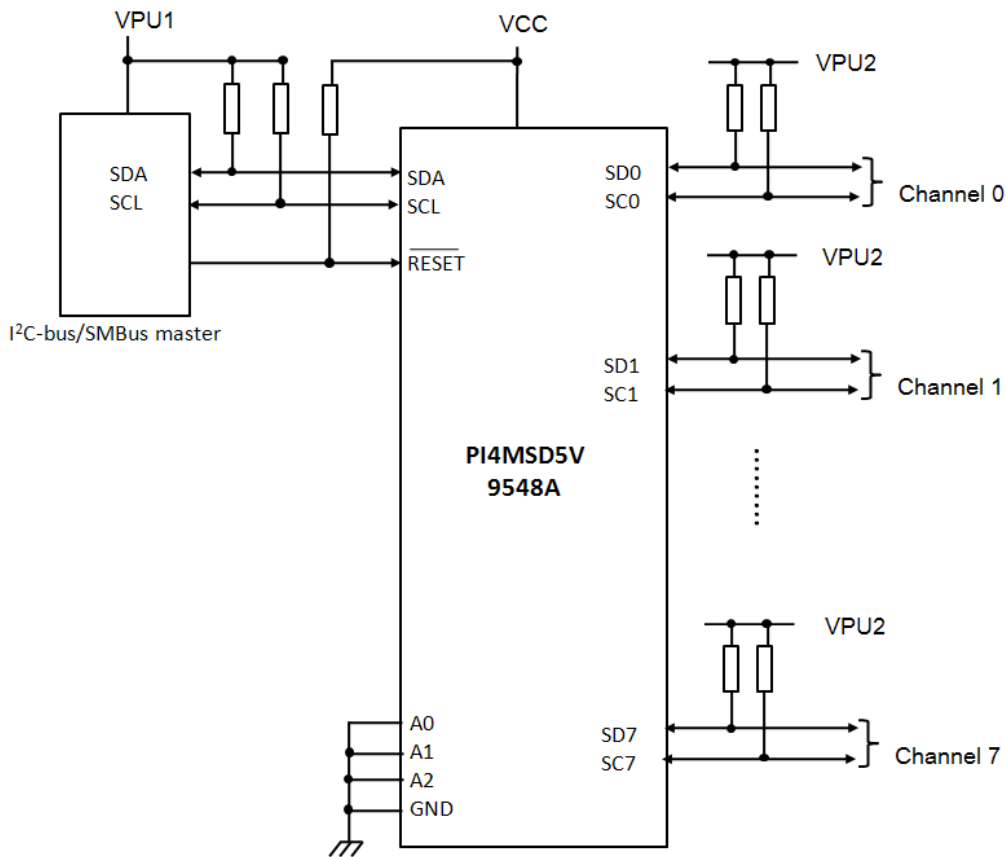

Figure 3. Typical Application

Recommended application voltage condition

VCC	VPU1	VPU2
1.8V	1.5V-5.5V	1.2V-5.5V
2.5V	1.8V-5.5V	1.8V-5.5V
3.3V	2.7V-5.5V	2.7V-5.5V
5V	4.5V-5.5V	4.5V-5.5V

## Device addressing

Following a START condition the bus master must output the address of the slave it is accessing. The address of the PI4MSD5V9548A is shown in Figure 4.

The last bit of the slave address defines the operation to be performed. When set to logic 1 a read is selected, while a logic 0 selects a write operation.



Figure 4: Device address

## Control register

Following the successful acknowledgement of the slave address, the bus master sends a byte to the PI4MSD5V9548A which is stored in the Control register. If multiple bytes are received by the PI4MSD5V9548A, it saves the last byte received. This register can be written and read via the I2C-bus.

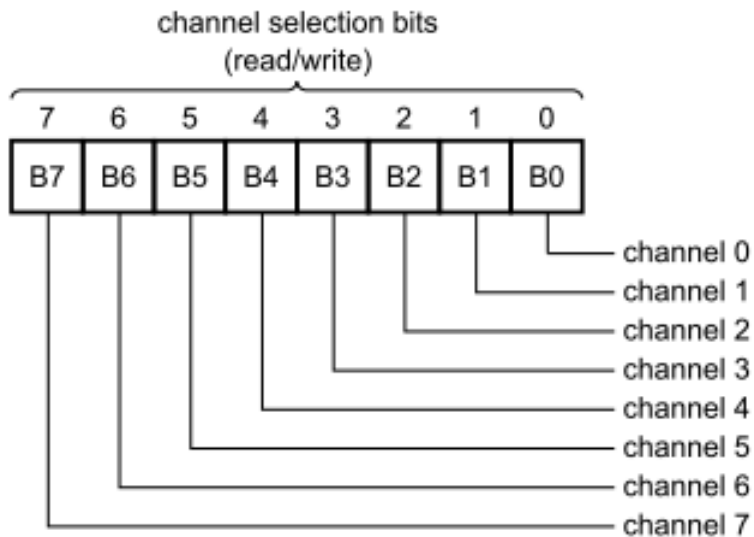

Figure 5: Control register

### Control register definition

One or several SCx/SDx downstream pair, or channel, is selected by the contents of the control register. This register is written after the PI4MSD5V9548A has been addressed. The 2 LSBs of the control byte are used to determine which channel is to be selected. When a channel is selected, the channel will become active after a STOP condition has been placed on the I2C-bus. This ensures that all SCx/SDx lines will be in a HIGH state when the channel is made active, so that no false conditions are generated at the time of connection.

Control register

B7	B6	B5	B4	B3	B2	B1	B0	Command
X	X	X	X	X	X	X	0 1	Channel 0 disabled Channel 0 enabled
X	X	X	X	X	X	0 1	X	Channel 1 disabled Channel 1 enabled
X	X	X	X	X	0 1	X	X	Channel 2 disabled Channel 2 enabled
X	X	X	X	0 1	X	X	X	Channel 3 disabled Channel 3 enabled
X	X	X	0 1	X	X	X	X	Channel 4 disabled Channel 4 enabled
X	X	0 1	X	X	X	X	X	Channel 5 disabled Channel 5 enabled
X	0 1	X	X	X	X	X	X	Channel 6 disabled Channel 6 enabled
0 1	X	X	X	X	X	X	X	Channel 7 disabled Channel 7 enabled

Control register: Write — channel selection; Read — channel status

### Power-on reset

When power is applied to VCC, an internal Power-On Reset (POR) holds the PI4MSD5V9548A in a reset condition until VCC has reached VPOR. At this point, the reset condition is released and the PI4MSD5V9548A registers and I2C-bus state machine are initialized to their default states (all zeroes), causing all the channels to be deselected. Thereafter, VCC must be lowered below 0.2 V for at least 5 us in order to reset the device.

### The Reset input

The RESET input is an active LOW signal which may be used to recover from a bus fault condition. By asserting this signal LOW for a minimum of  $t_{w(rst)L}$ , the PI4MSD5V9548A will reset its register and I2C-bus state machine and will deselect all channels. The RESET input must be connected to VCC through a pull-up resistor.

## Voltage translation

The pass gate transistors of the PI4MSD5V9548A are constructed such that the VCC voltage can be used to limit the maximum voltage that is passed from one I2C-bus to another.

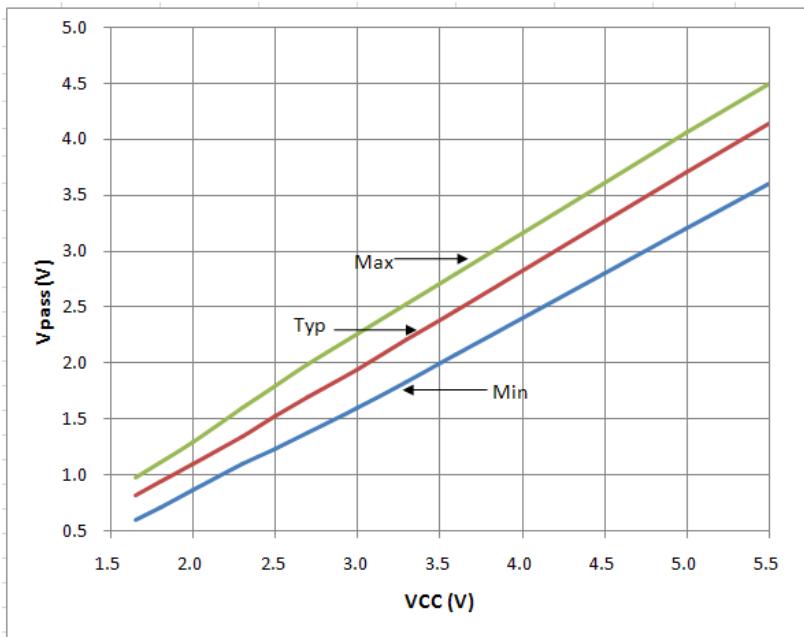

Figure 6: Vpass voltage VS Vcc

Figure 6 shows the voltage characteristics of the pass gate transistors (note that the graph was generated using the data specified in Section “DC Electrical characteristics” of this data sheet).

In order for the PI4MSD5V9548A to act as a voltage translator, the Vpass voltage should be equal to, or lower than the lowest bus voltage. For example, if the main bus was running at 5 V, and the downstream buses were 3.3 V and 2.7 V, then Vpass should be equal to or below 2.7 V to clamp the downstream bus voltages effectively.

Looking at Figure 6, we see that Vpass (max) is at 2.7 V when the PI4MSD5V9548A supply voltage is 3.5 V or lower so the PI4MSD5V9548A supply voltage could be set to 3.3 V. Pull-up resistors can then be used to bring the bus voltages to their appropriate levels

## I2C BUS

The I2C-bus is for 2-way, 2-line communication between different ICs or modules. The two lines are a serial data line (SDA) and a serial clock line (SCL). Both lines must be connected to a positive supply via a pull-up resistor when connected to the output stages of a device. Data transfer may be initiated only when the bus is not busy.

One data bit is transferred during each clock pulse. The data on the SDA line must remain stable during the HIGH period of the clock pulse as changes in the data line at this time are interpreted as control signals

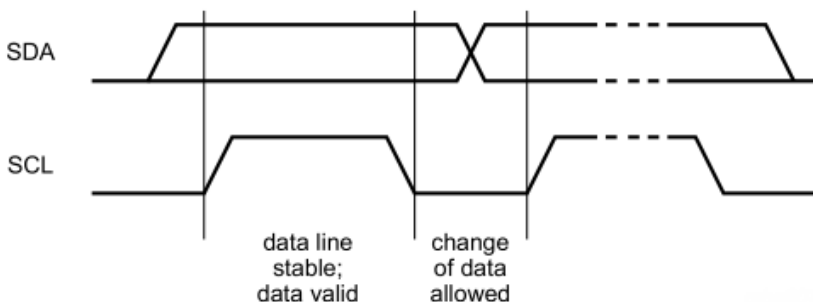

Figure 7: Bit Transfer



Both data and clock lines remain HIGH when the bus is not busy. A HIGH-to-LOW transition of the data line while the clock is HIGH is defined as the START condition (S). A LOW-to-HIGH transition of the data line while the clock is HIGH is defined as the STOP condition (P)

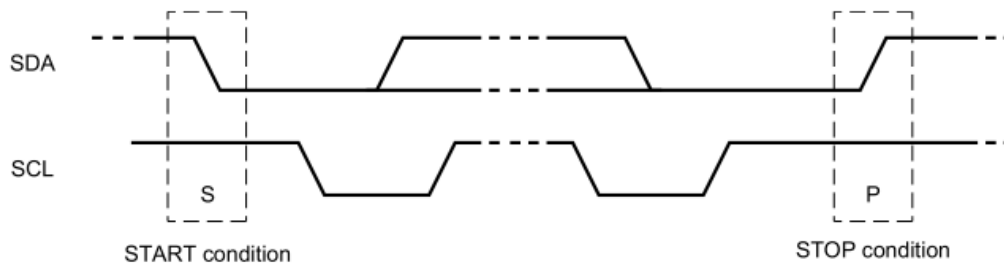

Figure 8. Definition of Start and Stop Conditions

A device generating a message is a ‘transmitter’, a device receiving is the ‘receiver’. The device that controls the message is the ‘master’ and the devices which are controlled by the master are the ‘slaves’

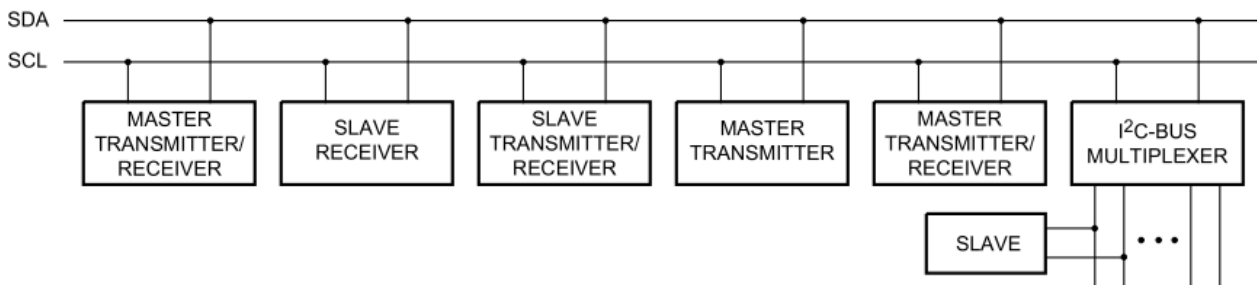

Figure 9. System Configuration

The number of data bytes transferred between the START and the STOP conditions from transmitter to receiver is not limited. Each byte of 8 bits is followed by one acknowledge bit. The acknowledge bit is a HIGH level put on the bus by the transmitter, whereas the master generates an extra acknowledge related clock pulse.

A slave receiver which is addressed must generate an acknowledge after the reception of each byte. Also, a master must generate an acknowledge after the reception of each byte that has been clocked out of the slave transmitter. The device that acknowledges has to pull down the SDA line during the acknowledge clock pulse so that the SDA line is stable LOW during the HIGH period of the acknowledge related clock pulse; set-up and hold times must be taken into account.

A master receiver must signal an end of data to the transmitter by not generating an acknowledge on the last byte that has been clocked out of the slave. In this event, the transmitter must leave the data line HIGH to enable the master to generate a STOP condition.

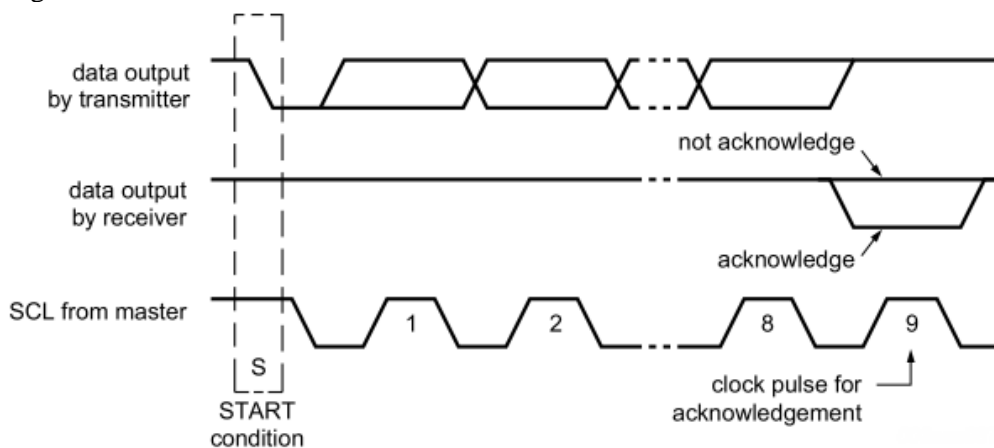

Figure 10. Acknowledgment on I2C Bus

Data is transmitted to the PI4MSD5V9548A control register using the write mode shown in bellow

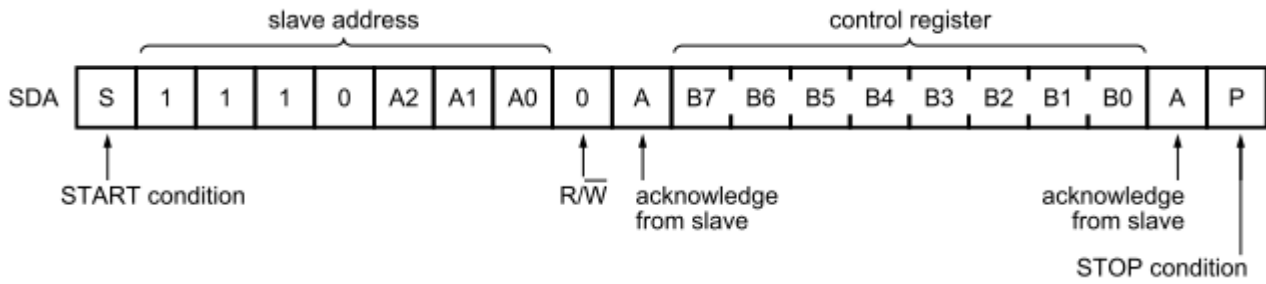

Figure 11. Write Control Register

Data is transmitted to the PI4MSD5V9548A control register using the write mode shown in bellow

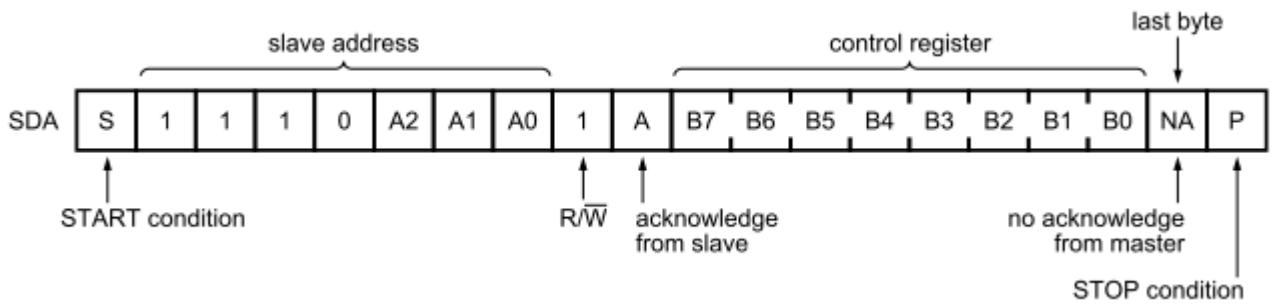
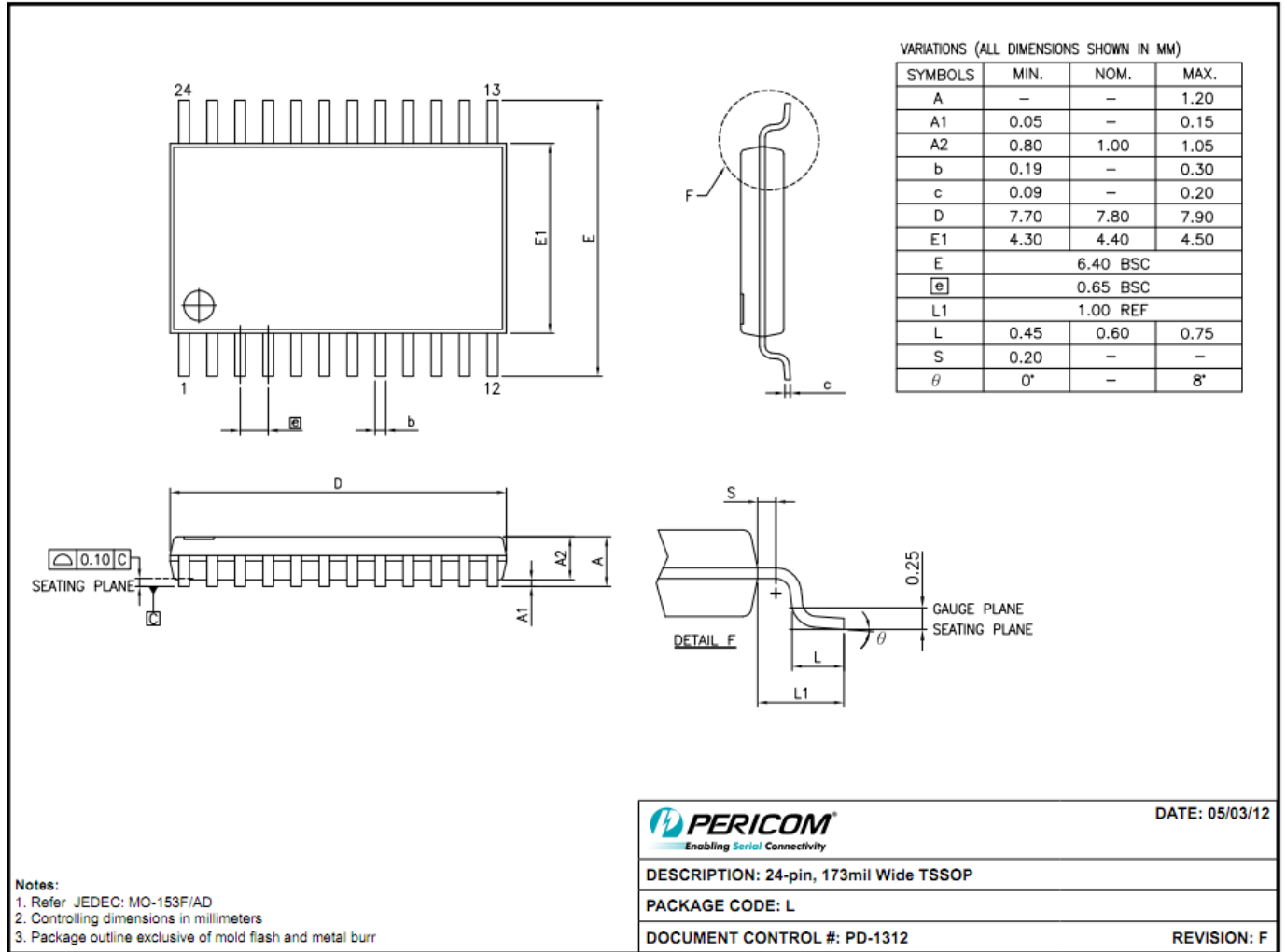
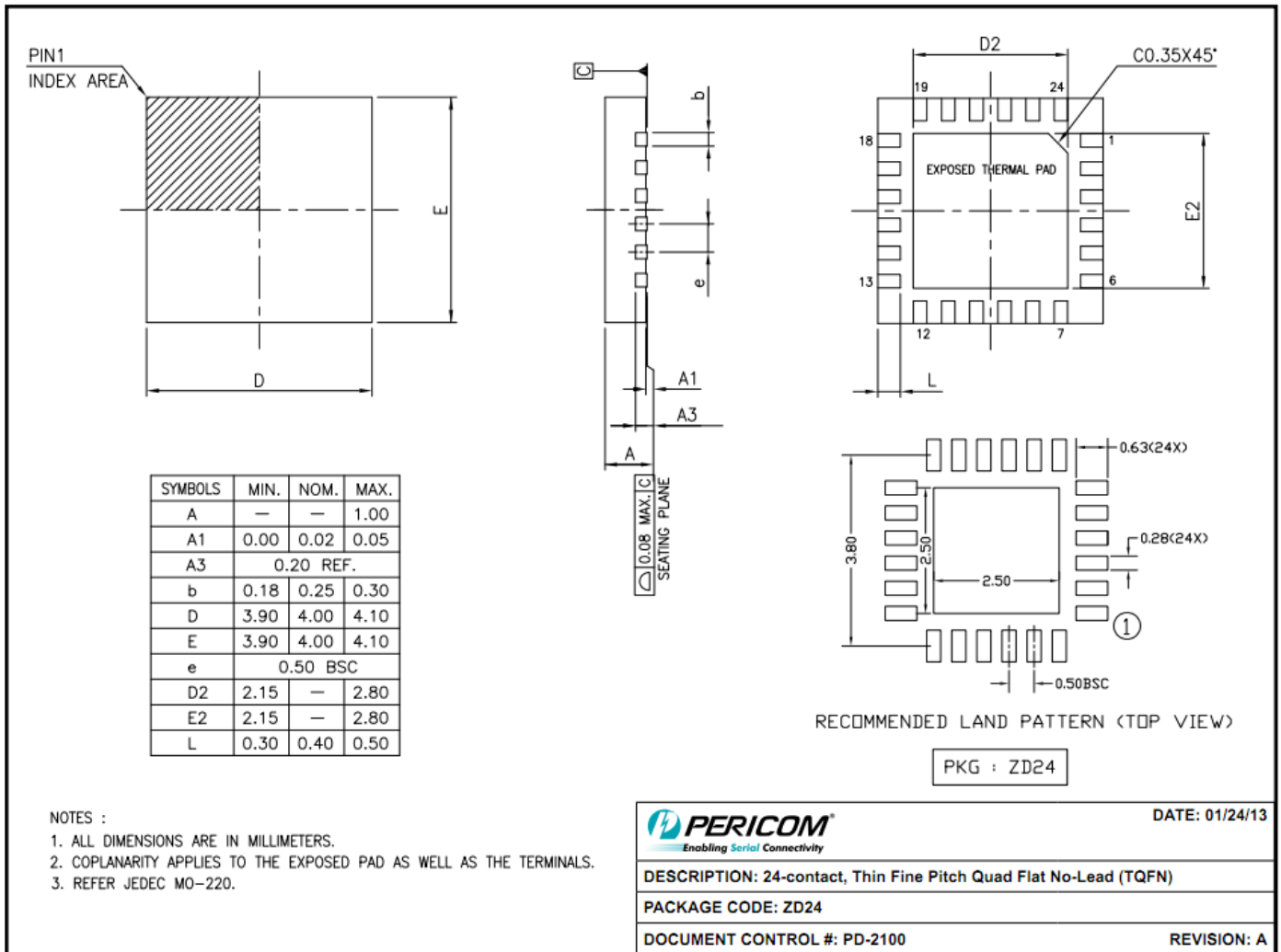

Figure 12. Read Control Register

**Mechanical Information**
**TSSOP-24(L)**

**TQFN-24(ZD)**



**Ordering Information**

Part No.	Package Code	Package
PI4MSD5V9548ALE	L	24-Pin, 173 mil Wide TSSOP
PI4MSD5V9548ALEX	L	24-Pin, 173 mil Wide TSSOP, Tape & Reel
PI4MSD5V9548AZDEX	ZD	24-Pin, Thine Fine Pitch Quad Flat No-Load(TQFN), Tape & Reel

**Note:**

- E = Pb-free and Green
- Adding X Suffix= Tape/Reel

Pericom Semiconductor Corporation • 1-800-435-2336 • [www.pericom.com](http://www.pericom.com)

Pericom reserves the right to make changes to its products or specifications at any time, without notice, in order to improve design or performance and to supply the best possible product. Pericom does not assume any responsibility for use of any circuitry described other than the circuitry embodied in Pericom product. The company makes no representations that circuitry described herein is free from patent infringement or other rights, of Pericom.



## Стандарт Электрон Связь

Мы молодая и активно развивающаяся компания в области поставок электронных компонентов. Мы поставляем электронные компоненты отечественного и импортного производства напрямую от производителей и с крупнейших складов мира.

Благодаря сотрудничеству с мировыми поставщиками мы осуществляем комплексные и плановые поставки широчайшего спектра электронных компонентов.

Собственная эффективная логистика и склад в обеспечивает надежную поставку продукции в точно указанные сроки по всей России.

Мы осуществляем техническую поддержку нашим клиентам и предпродажную проверку качества продукции. На все поставляемые продукты мы предоставляем гарантию .

Осуществляем поставки продукции под контролем ВП МО РФ на предприятия военно-промышленного комплекса России , а также работаем в рамках 275 ФЗ с открытием отдельных счетов в уполномоченном банке. Система менеджмента качества компании соответствует требованиям ГОСТ ISO 9001.

Минимальные сроки поставки, гибкие цены, неограниченный ассортимент и индивидуальный подход к клиентам являются основой для выстраивания долгосрочного и эффективного сотрудничества с предприятиями радиоэлектронной промышленности, предприятиями ВПК и научно-исследовательскими институтами России.

С нами вы становитесь еще успешнее!

### Наши контакты:

**Телефон:** +7 812 627 14 35

**Электронная почта:** [sales@st-electron.ru](mailto:sales@st-electron.ru)

**Адрес:** 198099, Санкт-Петербург,  
Промышленная ул, дом № 19, литера Н,  
помещение 100-Н Офис 331