

High Voltage Dual EL Lamp Driver

Features

- Independent input control for lamp selection
- Split supply capability
- Patented output timing
- One miniature inductor to power both lamps
- Low shutdown current
- Wide input voltage range 2.0V to 5.8V
- Output voltage regulation
- No SCR output
- Available in small packages (10-lead MSOP and 10-lead DFN/MLP)

Applications

- Mobile cellular phones, dual display
- Keypad and LCD backlighting
- Portable instrumentation
- Dual segment lamps
- Hand held wireless communication devices

General Description

The Supertex HV839 is a high voltage driver designed for driving two EL lamps with a combined area of 3.5 square inches. The input supply voltage range is from 2.0V to 5.8V. The device is designed to reduce the amount of audible noise emitted by the lamp. This device uses a single inductor and minimum number of passive components to drive two EL lamps. The nominal regulated output voltage of $\pm 90V$ is applied to the EL lamps. The two EL lamps can be turned ON and OFF by the two logic input control pins, C₁ and C₂. The device is disabled when both C₁ and C₂ (pins 1 and 4) are at logic low.

The HV839 has an internal oscillator, a switching MOSFET, and two high voltage EL lamp drivers. An external resistor connected between the R_{SW-OSC} pin and the voltage supply pin V_{DD} sets the frequency for the switching MOSFET. The EL lamp driver frequency is set by dividing the MOSFET switching frequency by 128. An external inductor is connected between the L_X and the V_{DD} pins. Depending on the EL lamp size, a 1.0 to 10.0nF, 100V capacitor is connected between C_S and Ground. The two EL lamps are connected between EL₁ to Com and EL₂ to Com. The switching MOSFET charges the external inductor and discharges it into the capacitor at C_S. The voltage at C_S increases. Once the voltage at C_S reaches a nominal value of 90V, the switching MOSFET is turned OFF to conserve power. The outputs EL₁ to Com and EL₂ to Com are configured as H bridges and switch in opposite states to achieve 180V across the EL lamp.

Typical Application Circuit

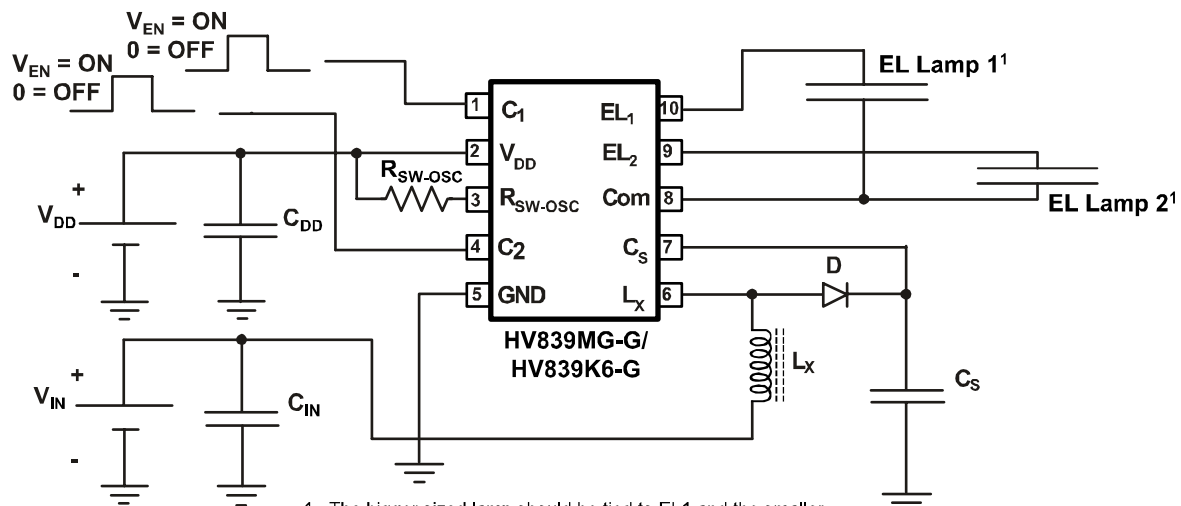

1 The bigger sized lamp should be tied to EL1 and the smaller sized lamp to EL2 terminals (pins 10 and 9 respectively)

Ordering Information

Device	Package Options	
	DFN/MLP-10 ¹	MSOP-10 ²
HV839	HV839K6-G	HV839MG-G

¹ Product supplied on 3000 piece carrier tape reels only

² Product supplied on 2500 piece carrier tape reels only

-G indicates package is RoHS compliant - "Green"



Absolute Maximum Ratings*

Supply Voltage, V_{DD}	-0.5V to 7.5V
Output Voltage, V_{CS}	-0.5V to 120V
Operating Temperature Range	-40°C to 85°C
Storage temperature	-65°C to 150°C

*Absolute Maximum Ratings are those values beyond which damage to the device may occur. Functional operation under these conditions is not implied. Continuous operation of the device at the absolute rating level may affect device reliability. All voltages are referenced to device ground, Gnd

Recommended Operating Conditions

Symbol	Parameter	Min	Typ	Max	Units	Conditions
V_{DD}	Supply Voltage	2.0		5.8	V	
T_A	Operating Temperature	-40		85	°C	

Function Table

C_1	C_2	EL_1	EL_2	Com	IC
0	0	Hi Z	Hi Z	Hi Z	OFF
0	1	Hi Z	ON	ON	ON
1	0	ON	Hi Z	ON	ON
1	1	ON	ON	ON	ON

Pin Configuration

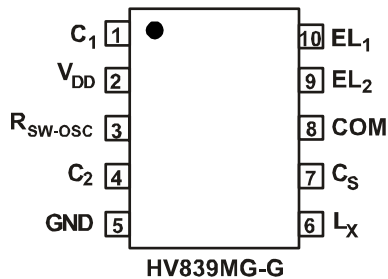

Top View: MSOP-10

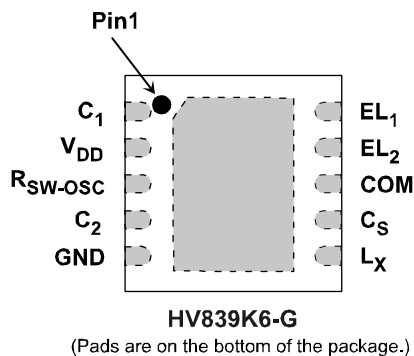

Top View: DFN/MLP-10

Electrical Characteristics

DC Characteristics (Over recommended operating conditions unless otherwise specified, $T_A=25^{\circ}\text{C}$)

Symbol	Parameter	Min	Typ	Max	Units	Conditions
$R_{DS(ON)}$	On-resistance of switching transistor			6.0	Ω	$I = 100\text{mA}$
V_{DD}	Input Voltage Range	2.0		5.8	V	
V_{CS}	Output regulation voltage	80	90	100	V	$V_{DD} = 2.0\text{V to } 5.8\text{V}$
V_{DIFF}	Differential output peak to peak voltage (EL ₁ to Com, EL ₂ to Com)	160	180	200	V	$V_{DD} = 2.0\text{V to } 5.8\text{V}$
I_{DDQ}	Quiescent V_{DD} supply current			150	nA	$C_1 = C_2 = 0 \text{ to } 0.1\text{V}$
				500	nA	$C_1 = C_2 = 0.1 \text{ to } 0.3\text{V}$
I_{DD}	Input current into the V_{DD} pin			190	μA	$V_{DD} = 2.0\text{V to } 5.8\text{V}$
I_{IN}	Input current including inductor current when driving both lamps			60	mA	$V_{IN} = 3.0\text{V}$, See Figure 1. $T_A = -40^{\circ}\text{C to } +85^{\circ}\text{C}$
			45	53		$V_{IN} = 3.0\text{V}$, See Figure 1. $T_A = +25^{\circ}\text{C}$
V_{CS}	Output voltage on V_{CS} when driving both lamps		76.2		V	$V_{IN} = 3.0\text{V}$. See Figure 1.
V_{DIFF}	Differential output peak to peak voltage across each lamp (EL ₁ to Com, EL ₂ to Com)		152.4		V	$V_{IN} = 3.0\text{V}$. See Figure 1.
f_{EL}	V_{DIFF} output drive frequency	440	500	560	Hz	$V_{IN} = 3.0\text{V}$. See Figure 1.
f_{SW}	Switching transistor frequency	56.3	64.0	71.7	kHz	$V_{IN} = 3.0\text{V}$. See Figure 1.
$f_{SW \text{ Drift}}$	Switching transistor frequency drift			± 5.0	kHz	$T_A = -40^{\circ}\text{C to } +85^{\circ}\text{C}$
D	Switching Transistor Duty cycle	85		89	%	
I_{IL}	Input logic low current going into the control pin			-0.6	μA	$V_{DD} = 2.0\text{V to } 5.8\text{V}$
I_{IH}	Input logic high current going into the control pin			0.6	μA	$V_{DD} = 2.0\text{V to } 5.8\text{V}$
V_{EN-L}	Logic input low voltage	0		0.3	V	
V_{EN-H}	Logic input high voltage	1.5		V_{DD}	V	

Thermal Resistance

(Mounted on FR4 board, 25mm x 25mm x 1.57mm)

Package	θ_{ja}
MSOP-10	400 $^{\circ}\text{C/W}$
DFN/MLP-10	60 $^{\circ}\text{C/W}$

Functional Block Diagram

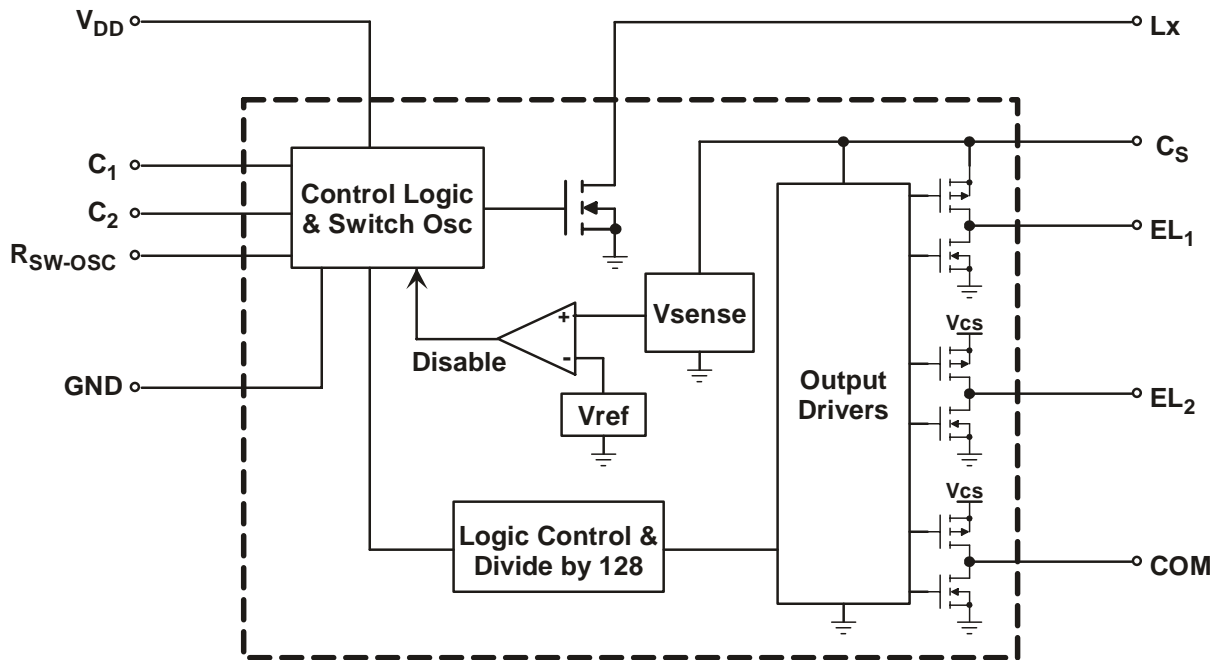
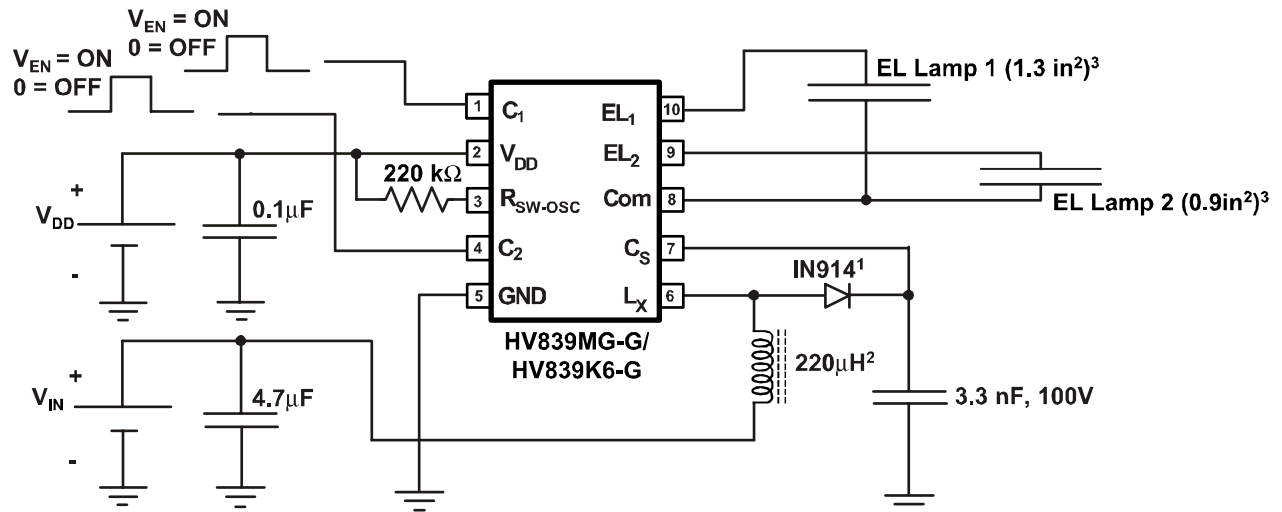

Figure 1: Test Circuit



- 1 or any (equivalent or better) > 90V, fast recovery diode
- 2 Murata LQH32CN221K21
- 3 The bigger sized lamp should be tied to EL1 and the smaller sized lamp to EL2 terminals (pins 10 and 9 respectively)

Device	Lamp	$V_{IN} = V_{DD}$	I_{IN}	V_{CS}	f_{EL}	Brightness
HV839MG-G or HV839K6-G	EL1	3.0V	29.6mA	85.8	500Hz	13.68ft-lm
	Both EL1 and EL2 ON		45.0mA	76.2		12.66ft-lm

Typical HV839 Performance Curves
 (EL_1 Lamp = $1.3in^2$, EL_2 = Lamp = $0.93in^2$, $V_{DD} = 3.0V$)

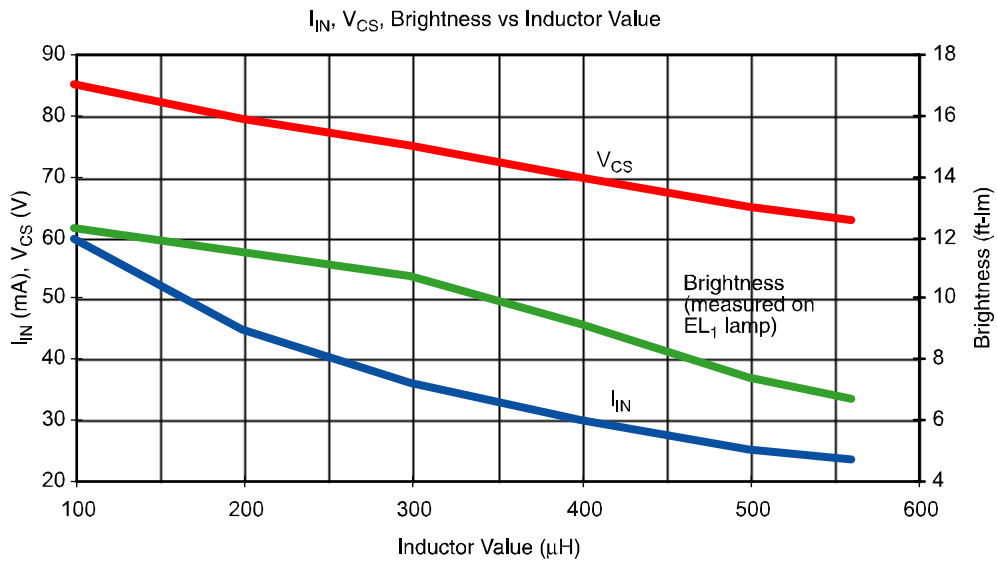
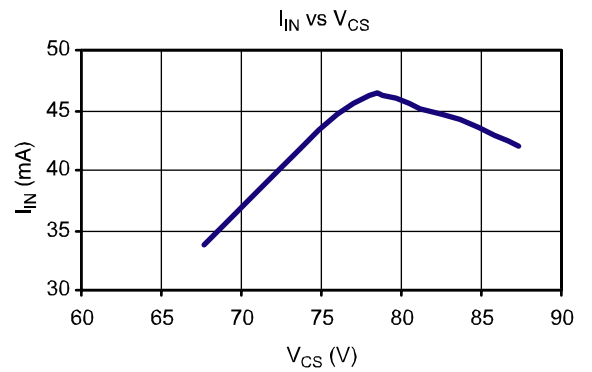
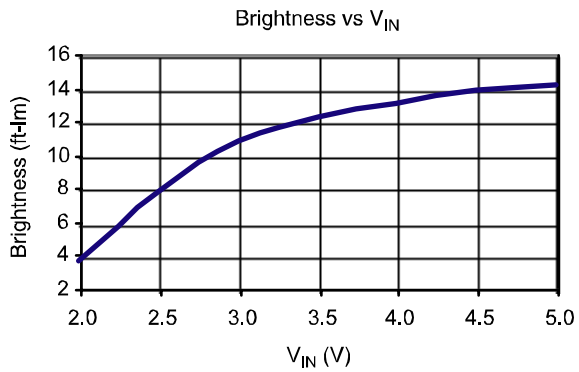
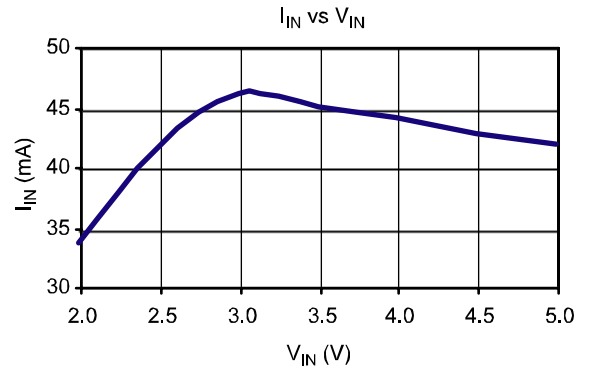
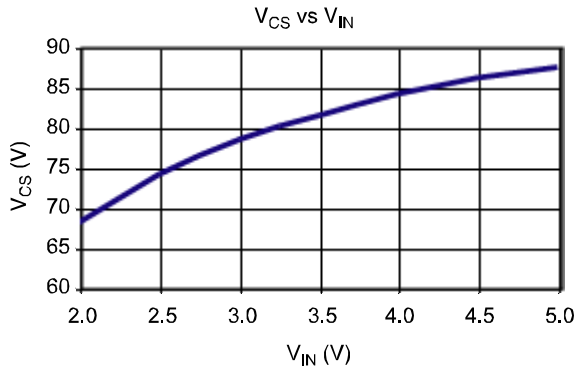

Pin Configuration and Description

Pin #	Name	Function
1	C ₁	Enable input signal for EL lamp 1. Logic high will turn ON the EL lamp 1 and logic low will turn it OFF. Refer Function Table.
2	V _{DD}	Input supply voltage pin.
3	R _{SW-OSC}	<p>External resistor connection to set both the switching MOSFET frequency and EL Lamp frequency. The external resistor should be connected between this pin and the V_{DD} pin. The EL lamp frequency is switching frequency divided by 128.</p> <p>The switching frequency increases as the value of R_{SW-OSC} decreases. A 220kΩ resistor will provide a switching frequency of 64.0 kHz, and an EL lamp frequency of 500 Hz. To change the frequency to f_{EL1}, the value of the resistor R_{SW-OSC1} can be determined as $R_{SW-OSC1} = (220 \times 500) / f_{EL1}$ kΩ.</p>
4	C ₂	Enable input signal for EL lamp 2. Logic high will turn ON the EL lamp 2 and logic low will turn it OFF. Refer Function Table.
5	GND	IC Ground Pin.
6	L _X	<p>External inductor connection to boost the low input voltage using inductive flyback. Connect an inductor between V_{IN} and this pin. Also connect a high voltage fast recovery diode between this pin and the C_S pin. The anode of the diode needs to be connected to the L_X pin and the cathode to the C_S pin. In general, small valued inductors, which can handle more current, are more suitable for driving large sized lamps. As the inductor value decreases, the switching frequency should be increased to avoid saturation.</p> <p>When the switching MOSFET is turned ON, the inductor is being charged. When the MOSFET is turned OFF, the energy stored in the inductor is transferred to the high voltage capacitor connected at the C_S pin.</p>
7	C _S	Connect a 100V capacitor between this pin and GND. This capacitor stores the energy transferred from the inductor.
8	Com	Common connection for both EL lamps. Connect one end of both the lamps to this pin.
9	EL ₂	EL lamp 2 connection. For optimum performance, the smaller of the two lamps should be connected to this pin.
10	EL ₁	EL lamp 1 connection. For optimum performance, the larger of the two lamps should be connected to this pin.

Split Supply Configuration

The HV839 can be used in applications operating from a battery where a regulated voltage is available. This is shown in Figure 2. The regulated voltage can be used to drive the internal logic of HV839. The amount of current used to drive the internal logic is less than 190 μ A. Therefore, the regulated voltage could easily provide the current without being loaded down.

Figure 2: Split Supply Configuration

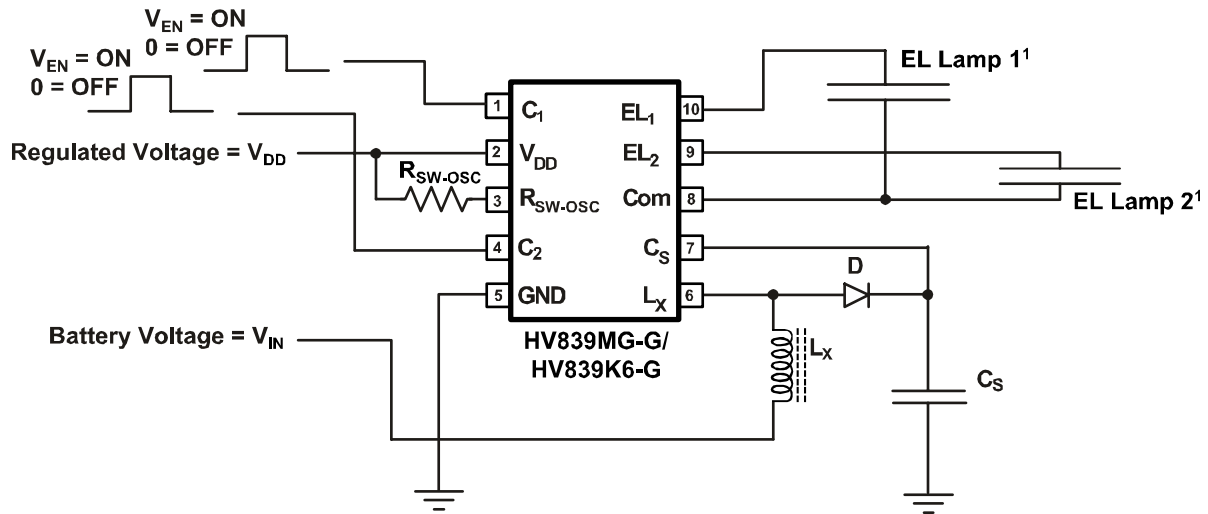

1 The bigger sized lamp should be tied to EL1 and the smaller sized lamp to EL2 terminals (pins 10 and 9 respectively)

Audible Noise Reduction

This section describes a method (patented) developed at Supertex to reduce the audible noise emitted by the EL lamps used in application sensitive to audible noise. The waveform takes the shape of approximately 2RC time constants for rising and 2RC time constants for falling, where C is the capacitance of the EL lamp, and R is the external resistor, R_{SER} connected in series with the EL lamp.

Figure 3 shows a general circuit schematic that uses the series resistors, R_{SER1} and R_{SER2} , for each of the EL lamps. R_{SER1} and R_{SER2} are connected in series with the EL lamp. The audible noise can be set a desirable level by selecting the resistances for R_{SER1} and R_{SER2} . It is important to note that addition of these external resistors will reduce the voltage across the EL lamp, and hence the brightness of the EL lamp.

Figure 3: Typical Application Circuit For Audible Noise Reduction

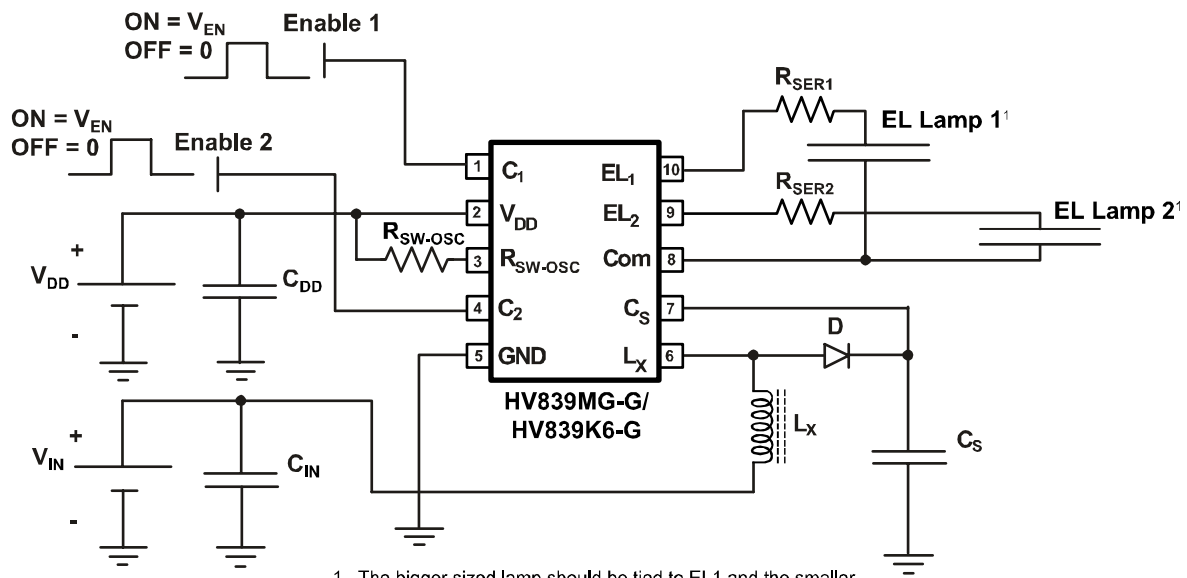

1 The bigger sized lamp should be tied to EL1 and the smaller sized lamp to EL2 terminals (pins 10 and 9 respectively)

10-Lead DFN/MLP Package Outline (K6)

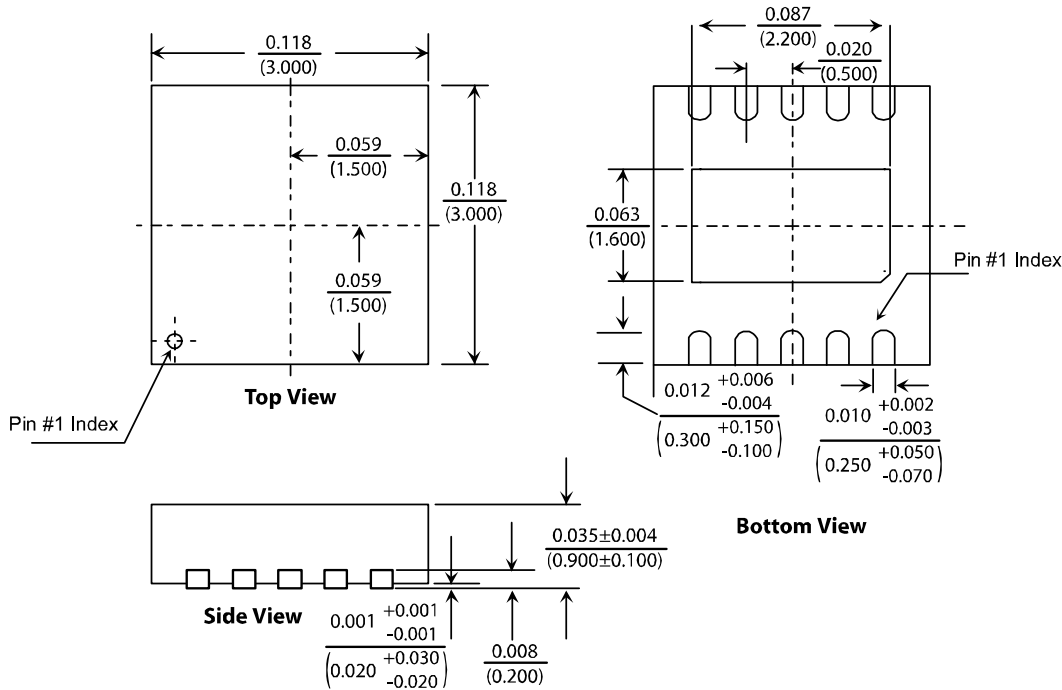

10-Lead MSOP Package Outline (MG)

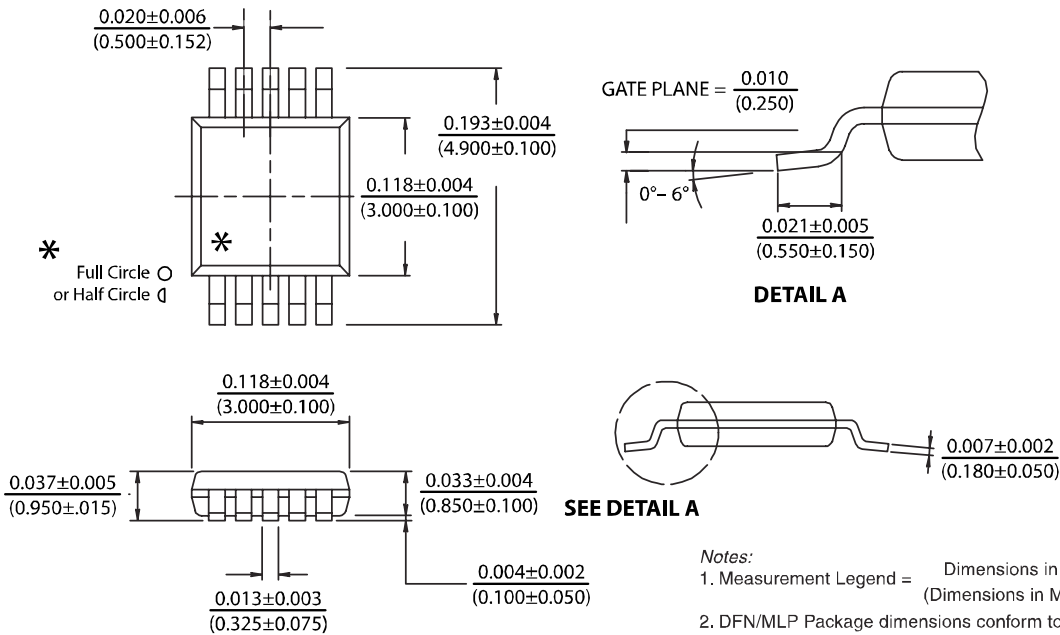

Supertex inc. does not recommend the use of its products in life support applications and will not knowingly sell its products for use in such applications unless it receives an adequate "products liability indemnification insurance agreement". *Supertex* does not assume responsibility for use of devices described and limits its liability to the replacement of the devices determined defective due to workmanship. No responsibility is assumed for possible omissions or inaccuracies. Circuitry and specifications are subject to change without notice. For the latest product specifications, refer to the *Supertex* website: <http://www.supertex.com>. For complete liability information on all *Supertex* products, refer to the most current databook or to the Legal/ Disclaimer page on the *Supertex* website.



Стандарт Электрон Связь

Мы молодая и активно развивающаяся компания в области поставок электронных компонентов. Мы поставляем электронные компоненты отечественного и импортного производства напрямую от производителей и с крупнейших складов мира.

Благодаря сотрудничеству с мировыми поставщиками мы осуществляем комплексные и плановые поставки широчайшего спектра электронных компонентов.

Собственная эффективная логистика и склад в обеспечивает надежную поставку продукции в точно указанные сроки по всей России.

Мы осуществляем техническую поддержку нашим клиентам и предпродажную проверку качества продукции. На все поставляемые продукты мы предоставляем гарантию .

Осуществляем поставки продукции под контролем ВП МО РФ на предприятия военно-промышленного комплекса России , а также работаем в рамках 275 ФЗ с открытием отдельных счетов в уполномоченном банке. Система менеджмента качества компании соответствует требованиям ГОСТ ISO 9001.

Минимальные сроки поставки, гибкие цены, неограниченный ассортимент и индивидуальный подход к клиентам являются основой для выстраивания долгосрочного и эффективного сотрудничества с предприятиями радиоэлектронной промышленности, предприятиями ВПК и научно-исследовательскими институтами России.

С нами вы становитесь еще успешнее!

Наши контакты:

Телефон: +7 812 627 14 35

Электронная почта: sales@st-electron.ru

Адрес: 198099, Санкт-Петербург,
Промышленная ул, дом № 19, литера Н,
помещение 100-Н Офис 331