



256K X 16 BIT LOW POWER CMOS SRAM

FEATURES

- Process Technology : 0.18μm Full CMOS
- Organization : 256K x 16 bit
- Power Supply Voltage : 2.7V ~ 3.6V
- Low Data Retention Voltage : 1.5V(Min.)
- Three state output and TTL Compatible
- Package Type : VFBGA-48, 44-TSOP2

GENERAL DESCRIPTION

The AS6C4016A families are fabricated by Alliance Memory advanced full CMOS process technology. The families support industrial temperature range and Chip Scale Package for user flexibility of system design. The families also support low data retention voltage for battery back-up operation with low data retention current.

PRODUCT FAMILY

Product Family	Operating Temperature	Vcc Range	Speed	Power Dissipation		PKG Type
				Standby (I _{SB1} , Typ.)	Operating (I _{SB1} .Max.)	
AS6C4016A	Industrial (-40 ~ 85°C)	2.7 ~ 3.6V	45 ns	0.25 μA ²⁾	3 mA	KGD VFBGA-48 44-TSOP2

2. Typical values are measured at Vcc=3.3V, TA=25°C and not 100% tested.

FUNCTIONAL BLOCK DIAGRAM

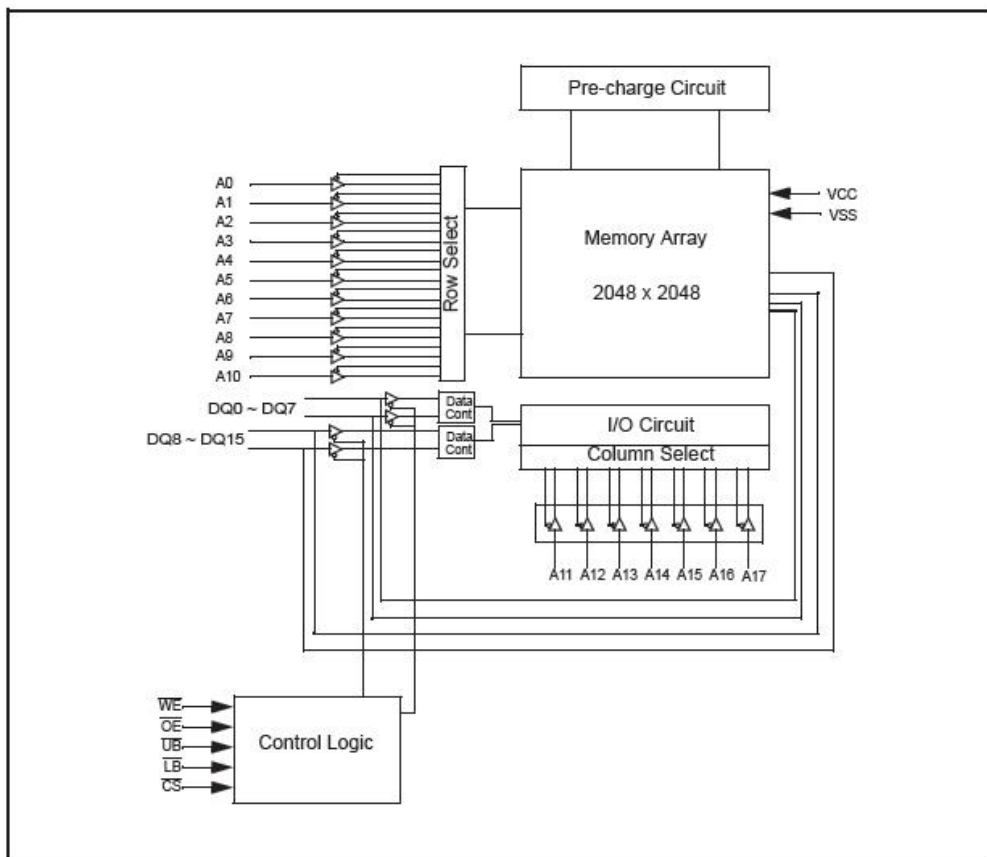



256K X 16 BIT LOW POWER CMOS SRAM

PIN CONFIGURATIONS

VFBGA-48 : Top view(ball down)

	1	2	3	4	5	6
A	$\overline{\text{LB}}$	$\overline{\text{OE}}$	A0	A1	A2	NC
B	DQ8	$\overline{\text{UB}}$	A3	A4	$\overline{\text{CS}}$	DQ0
C	DQ9	DQ10	A5	A6	DQ1	DQ2
D	VSS	DQ11	A17	A7	DQ3	VCC
E	VCC	DQ12	NC	A16	DQ4	VSS
F	DQ14	DQ13	A14	A15	DQ5	DQ6
G	DQ15	NC	A12	A13	$\overline{\text{WE}}$	DQ7
H	NC	A8	A9	A10	A11	NC

44 - TSOP2 : Top view

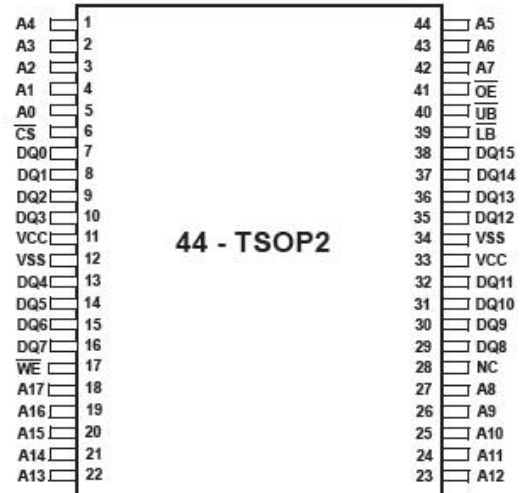

PIN DESCRIPTION

Name	Function	Name	Function
$\overline{\text{CS}}$	Chip Select input	VCC	Power Supply
$\overline{\text{OE}}$	Output Enable input	VSS	Ground
$\overline{\text{WE}}$	Write Enable input	$\overline{\text{UB}}$	Upper Byte (DQ8~DQ15)
A0~A17	Address inputs	$\overline{\text{LB}}$	Lower Byte (DQ0~DQ7)
DQ0~DQ15	Data inputs/outputs	NC	No Connection



256K X 16 BIT LOW POWER CMOS SRAM

ABSOLUTE MAXIMUM RATINGS¹⁾

Parameter	Symbol	Ratings	Unit
Voltage on Any Pin Relative to V _{SS}	V _{IN} , V _{OUT}	-0.2 to 4.0	V
Voltage on V _{CC} supply relative to V _{SS}	V _{CC}	-0.2 to 4.0	V
Power Dissipation	P _D	1.0	W
Operating Temperature	T _A	-40 to 85	°C

1. Stresses greater than those listed under "Absolute Maximum Ratings" may cause permanent damage to the device. Functional operation should be restricted to recommended operating condition. Exposure to absolute maximum rating conditions for extended periods may affect reliability.

FUNCTIONAL DESCRIPTION

$\overline{\text{CS}}$	$\overline{\text{OE}}$	$\overline{\text{WE}}$	$\overline{\text{LB}}$	$\overline{\text{UB}}$	DQ0~7	DQ8~15	Mode	Power
H	X	X	X	X	High-Z	High-Z	Deselected	Stand by
X	X	X	H	H	High-Z	High-Z	Deselected	Stand by
L	H	H	L	X	High-Z	High-Z	Output Disabled	Active
L	H	H	X	L	High-Z	High-Z	Output Disabled	Active
L	L	H	L	H	Data Out	High-Z	Lower Byte Read	Active
L	L	H	H	L	High-Z	Data Out	Upper Byte Read	Active
L	L	H	L	L	Data Out	Data Out	Word Read	Active
L	X	L	L	H	Data In	High-Z	Lower Byte Write	Active
L	X	L	H	L	High-Z	Data In	Upper Byte Write	Active
L	X	L	L	L	Data In	Data In	Word Write	Active

NOTE : X means don't care. (Must be low or high state)



256K X 16 BIT LOW POWER CMOS SRAM

RECOMMENDED DC OPERATING CONDITIONS ¹⁾

Parameter	Symbol	Min	Typ	Max	Unit
Supply voltage	V_{CC}	2.7	3.3	3.6	V
Ground	V_{SS}	0	0	0	V
Input high voltage	V_{IH}	2.2	-	$V_{CC} + 0.2^{2)}$	V
Input low voltage	V_{IL}	$-0.2^{3)}$	-	0.6	V

1. $T_A = -40$ to 85°C , otherwise specified
2. Overshoot: $V_{CC} + 2.0$ V in case of pulse width ≤ 20 ns
3. Undershoot: -2.0 V in case of pulse width ≤ 20 ns
4. Overshoot and undershoot are sampled, not 100% tested.

CAPACITANCE ¹⁾ ($f = 1\text{MHz}$, $T_A = 25^\circ\text{C}$)

Item	Symbol	Test Condition	Min	Max	Unit
Input capacitance	C_{IN}	$V_{IN} = 0\text{V}$	-	8	pF
Input/Output capacitance	C_{IO}	$V_{IO} = 0\text{V}$	-	10	pF

1. Capacitance is sampled, not 100% tested.

DC AND OPERATING CHARACTERISTICS

Parameter	Symbol	Test Conditions	Min	Typ	Max	Unit	
Input leakage current	I_{LI}	$V_{IN} = V_{SS}$ to V_{CC}	-1	-	1	μA	
Output leakage current	I_{LO}	$\overline{CS} = V_{IH}$ or $\overline{OE} = V_{IH}$ or $\overline{WE} = V_{IL}$ or $\overline{LB} = \overline{UB} = V_{IH}$ $V_{IO} = V_{SS}$ to V_{CC}	-1	-	1	μA	
Operating power supply	I_{CC}	$I_{IO} = 0\text{mA}$, $\overline{CS} = V_{IL}$, $V_{IN} = V_{IH}$ or V_{IL}	-	-	3	mA	
Average operating current	I_{CC1}	Cycle time = $1\mu\text{s}$, 100% duty, $I_{IO} = 0\text{mA}$, $\overline{CS} \leq 0.2\text{V}$, $\overline{LB} \leq 0.2\text{V}$ or/and $\overline{UB} \leq 0.2\text{V}$, $V_{IN} \leq 0.2\text{V}$ or $V_{IN} \geq V_{CC} - 0.2\text{V}$	-	-	3	mA	
	I_{CC2}	Cycle time = Min, $I_{IO} = 0\text{mA}$, 100% duty, $\overline{CS} = V_{IL}$, $\overline{LB} = V_{IL}$ or/and $\overline{UB} = V_{IL}$, $V_{IN} = V_{IL}$ or V_{IH}	55ns	-	-	30	mA
Output low voltage	V_{OL}	$I_{OL} = 2.1\text{mA}$	-	-	0.4	V	
Output high voltage	V_{OH}	$I_{OH} = -1.0\text{mA}$	2.4	-	-	V	
Standby Current (TTL)	I_{SB}	$\overline{CS} = V_{IH}$, Other inputs = V_{IH} or V_{IL}	-	-	0.3	mA	
Standby Current (CMOS)	I_{SB1}	$\overline{CS} \geq V_{CC} - 0.2\text{V}$, Other inputs = $0 \sim V_{CC}$ (Typ. condition : $V_{CC} = 3.3\text{V}$ @ 25°C) (Max. condition : $V_{CC} = 3.6\text{V}$ @ 85°C)	LL LF	-	$0.25^{1)}$	4	μA

1. Typical values are measured at $V_{CC} = 3.3\text{V}$, $T_A = 25^\circ\text{C}$ and not 100% tested.



256K X 16 BIT LOW POWER CMOS SRAM

AC OPERATING CONDITIONS**Test Conditions** (Test Load and Test Input/Output Reference)

Input Pulse Level : 0.4 to 2.2V

Input Rise and Fall Time : 5ns

Input and Output reference Voltage : 1.5V

Output Load (See right) : $CL^{(1)} = 100\text{pF} + 1 \text{ TTL}(70\text{ns})$ $CL^{(1)} = 30\text{pF} + 1 \text{ TTL}(45\text{ns}/55\text{ns})$

1. Including scope and Jig capacitance

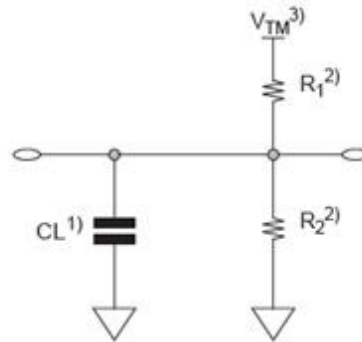
2. $R_1=3070\Omega$, $R_2=3150\Omega$ 3. $V_{TM}=2.8\text{V}$ 4. $CL = 5\text{pF} + 1 \text{ TTL}$ (measurement with tLZ, tOLZ, tHZ, tOHZ, tWHZ)**READ CYCLE** ($V_{CC} = 2.7$ to 3.6V , $Gnd = 0\text{V}$, $T_A = -40^\circ\text{C}$ to $+85^\circ\text{C}$)

	Symbol	45 ns		Unit
		Min	Max	
Read cycle time	t_{RC}	45	-	ns
Address access time	t_{AA}	-	45	ns
Chip select to output	t_{CO}	-	45	ns
Output enable to valid output	t_{OE}	-	20	ns
\overline{UB} , \overline{LB} access time	t_{BA}		45	ns
Chip select to low-Z output	t_{LZ}	10	-	ns
\overline{UB} , \overline{LB} enable to low-Z output	t_{BLZ}	5	-	ns
Output enable to low-Z output	t_{OLZ}	5	-	ns
Chip disable to high-Z output	t_{HZ}	0	20	ns
\overline{UB} , \overline{LB} disable to high-Z output	t_{BHZ}	0	20	ns
Output disable to high-Z output	t_{OHZ}	0	20	ns
Output hold from address change	t_{OH}	10	-	ns

WRITE CYCLE ($V_{CC} = 2.7$ to 3.6V , $Gnd = 0\text{V}$, $T_A = -40^\circ\text{C}$ to $+85^\circ\text{C}$)

Parameter	Symbol	45 ns		Unit
		Min	Max	
Write cycle time	t_{WC}	45	-	ns
Chip select to end of write	t_{CW}	45	-	ns
Address setup time	t_{AS}	0	-	ns
Address valid to end of write	t_{AW}	35	-	ns
\overline{UB} , \overline{LB} valid to end of write	t_{BW}	35	-	ns
Write pulse width	t_{WP}	35	-	ns
Write recovery time	t_{WR}	0	-	ns
Write to output high-Z	t_{WHZ}	0	20	ns
Data to write time overlap	t_{DW}	25		ns
Data hold from write time	t_{DH}	0	-	ns
End write to output low-Z	t_{OW}	5	-	ns



256K X 16 BIT LOW POWER CMOS SRAM

TIMING DIAGRAMS

TIMING WAVEFORM OF READ CYCLE(1) (Address Controlled, $\overline{CS}=\overline{OE}=V_{IL}$, $\overline{WE}=V_{IH}$, \overline{UB} or/and $\overline{LB}=V_{IL}$)

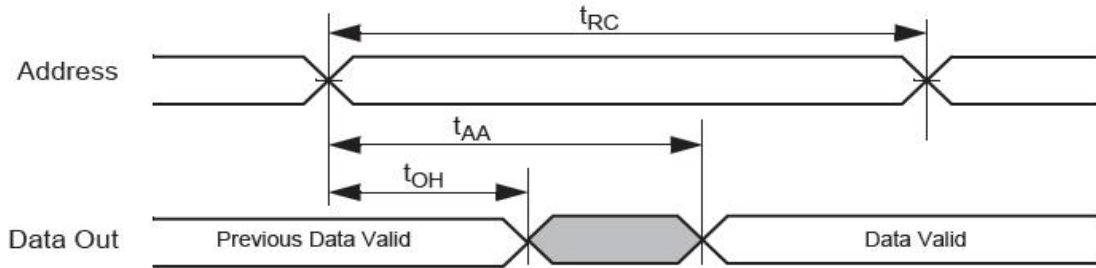

TIMING WAVEFORM OF READ CYCLE(2) ($\overline{WE} = V_{IH}$)

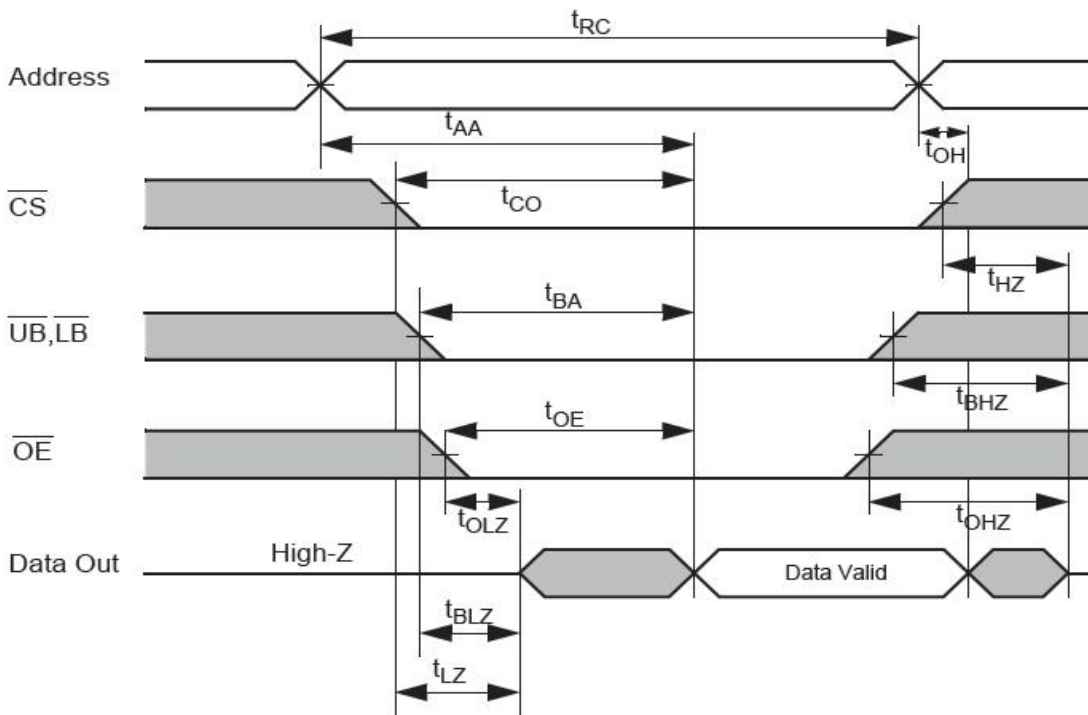

NOTES (READ CYCLE)

1. t_{HZ} and t_{OHZ} are defined as the outputs achieve the open circuit conditions and are not referenced to output voltage levels.
2. At any given temperature and voltage condition, $t_{HZ}(\text{Max.})$ is less than $t_{LZ}(\text{Min.})$ both for a given device and from device to device interconnection.



256K X 16 BIT LOW POWER CMOS SRAM

TIMING WAVEFORM OF WRITE CYCLE(1) (\overline{WE} Controlled)

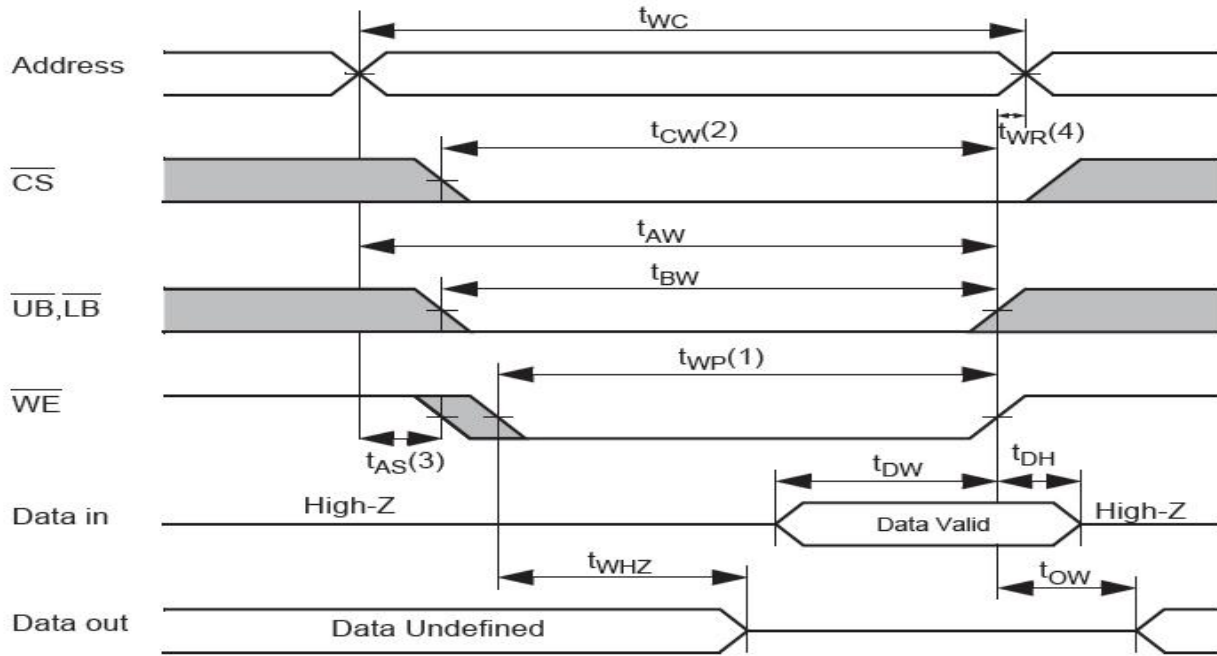

TIMING WAVEFORM OF WRITE CYCLE(2) (\overline{CS} Controlled)

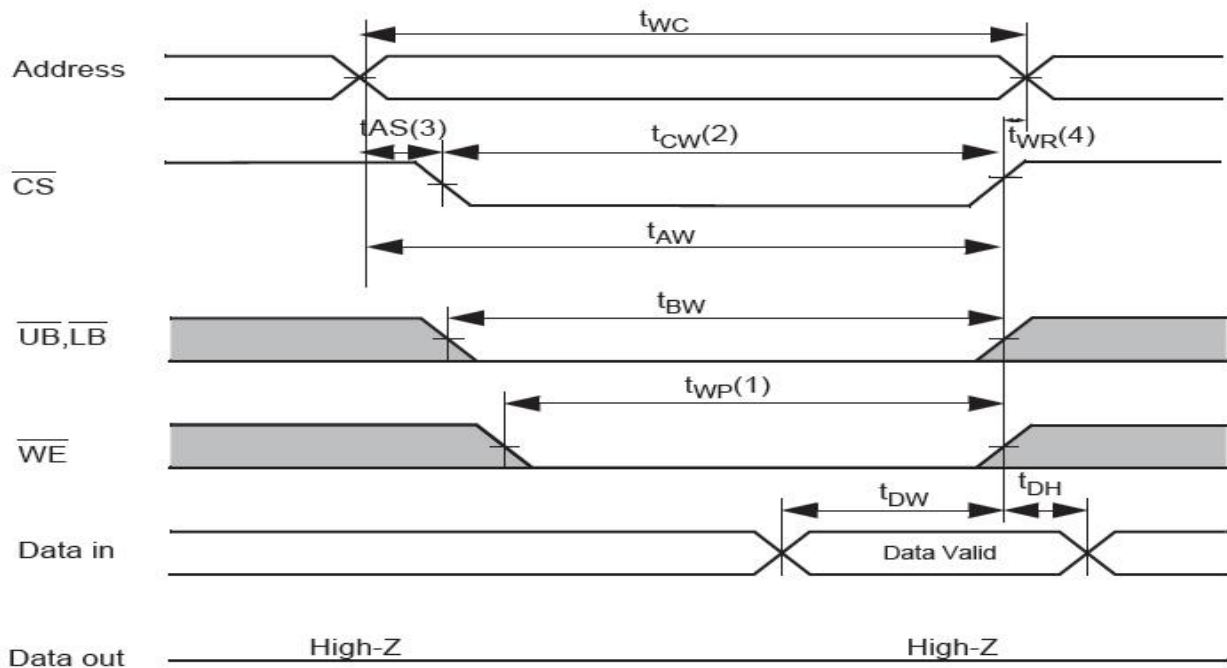

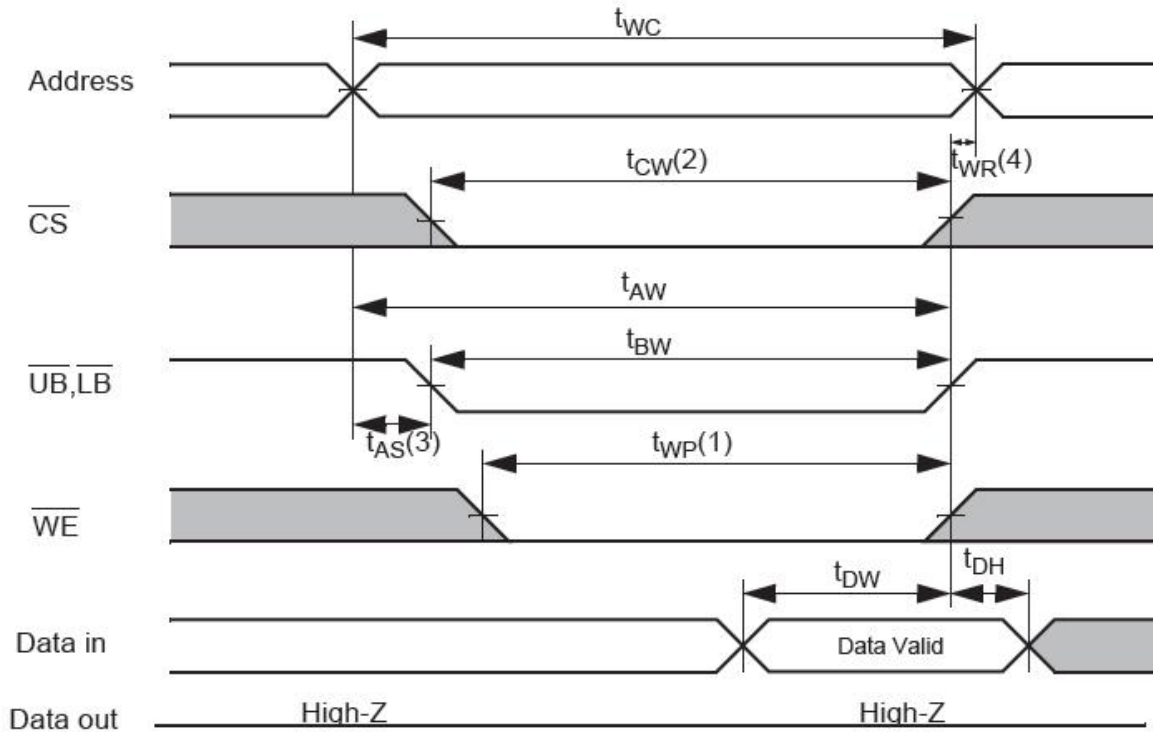

256K X 16 BIT LOW POWER CMOS SRAM

TIMING WAVEFORM OF WRITE CYCLE(3) (\overline{UB} , \overline{LB} Controlled)**NOTES (WRITE CYCLE)**

1. A write occurs during the overlap (t_{WP}) of low \overline{CS} and low \overline{WE} . A write begins when \overline{CS} goes low and \overline{WE} goes low with asserting \overline{UB} or \overline{LB} for single byte operation or simultaneously asserting \overline{UB} and \overline{LB} for double byte operation. A write ends at the earliest transition when \overline{CS} goes high and \overline{WE} goes high. The t_{WP} is measured from the beginning of write to the end of write.
2. t_{CW} is measured from the \overline{CS} going low to end of write.
3. t_{AS} is measured from the address valid to the beginning of write.
4. t_{WR} is measured from the end of write to the address change. t_{WR} applied in case a write ends as \overline{CS} or \overline{WE} going high.



256K X 16 BIT LOW POWER CMOS SRAM

DATA RETENTION CHARACTERISTICS

Parameter	Symbol	Test Condition	Min	Typ ²⁾	Max	Unit
V _{CC} for Data Retention	V _{DR}	I _{SB1} Test Condition (Chip Disabled) ¹⁾	1.5	-	3.6	V
Data Retention Current	I _{DR}	V _{CC} =1.5V, I _{SB1} Test Condition (Chip Disabled) ¹⁾	-	0.5	4	μA
Chip Deselect to Data Retention Time	t _{SDR}	See data retention wave form	0	-	-	ns
Operation Recovery Time	t _{RDR}		t _{RC}	-	-	

NOTES

1. See the I_{SB1} measurement condition of datasheet page 5.
2. Typical values are measured at T_A=25°C and not 100% tested.

DATA RETENTION WAVE FORM

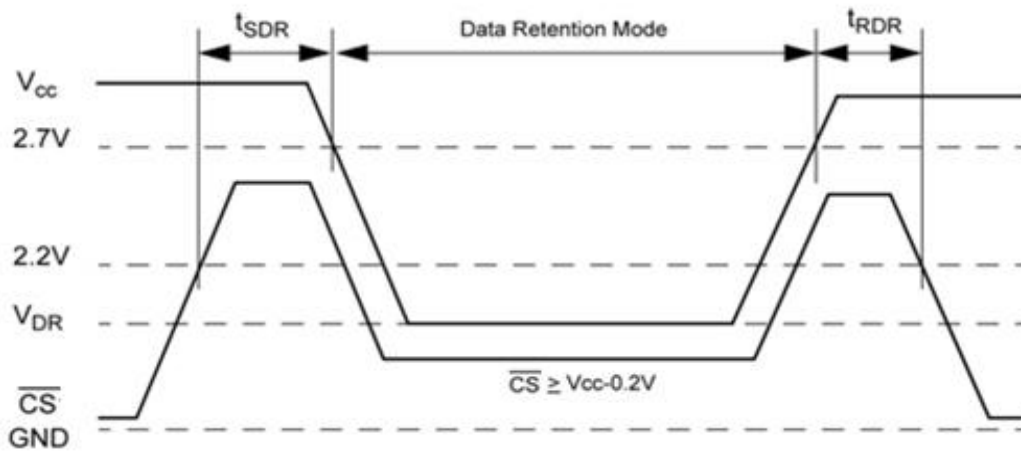



256K X 16 BIT LOW POWER CMOS SRAM

PACKAGE DIMENSION

44 - TSOP2 (0.8mm pin pitch)

Unit : millimeters / inches

44 PIN THIN SMALL OUTLINE PACKAGE TYPE II (400F)

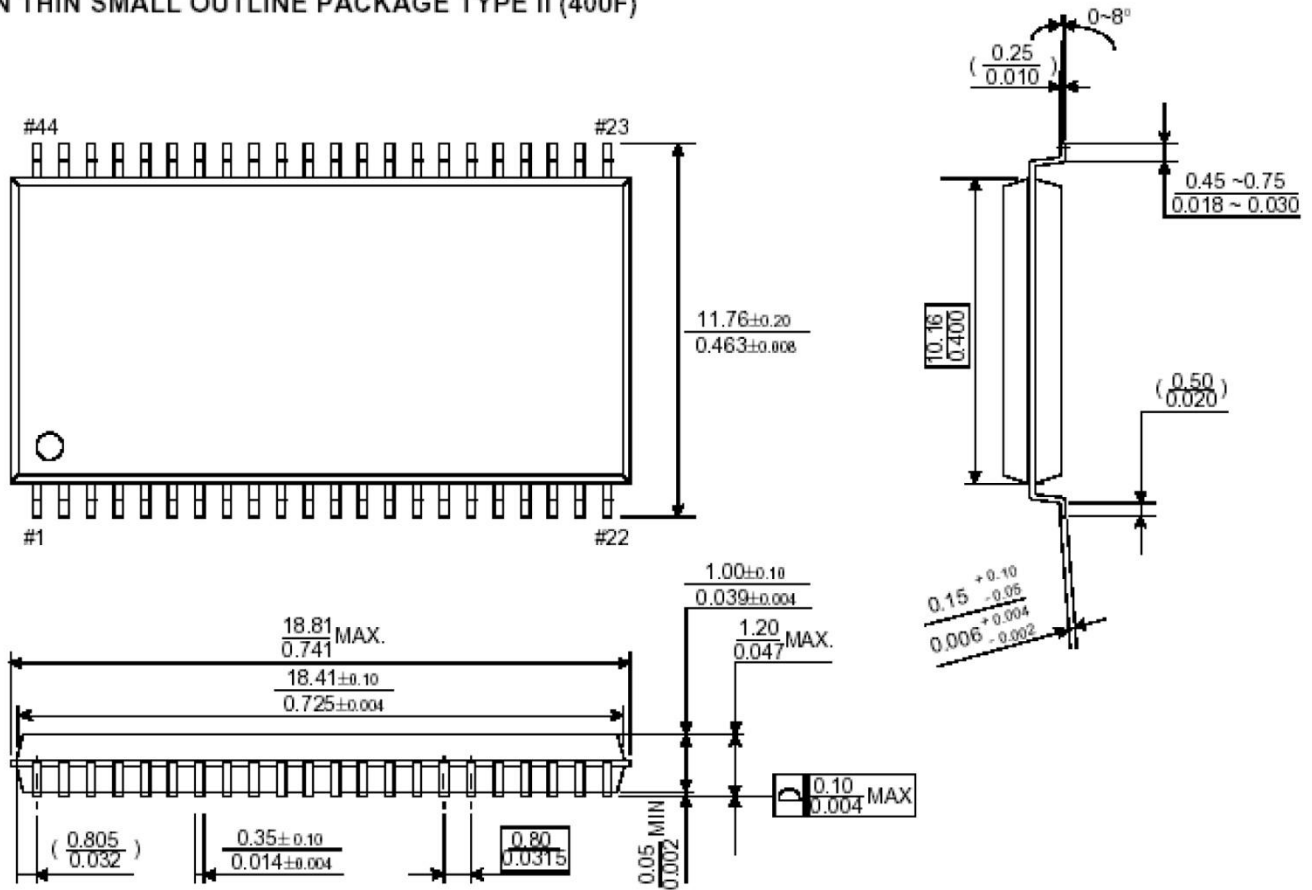



256K X 16 BIT LOW POWER CMOS SRAM

Unit: millimeters

VFBGA 48 BALLS (6X7X1 0.75mm ball pitch)

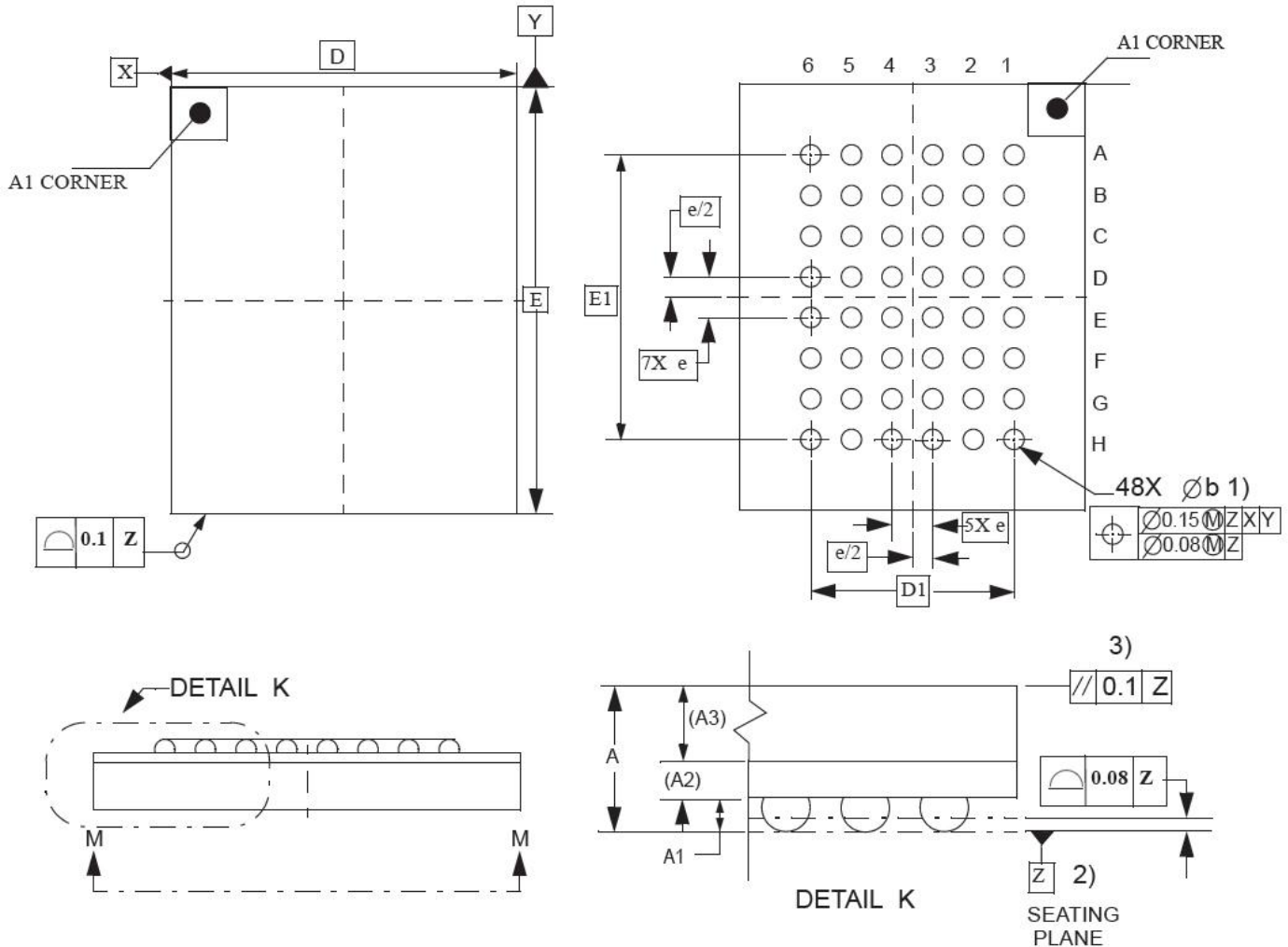

	Min.	NOR.	Max.
A	---		1
A1	0.22		0.32
A2		0.21 REF	
A3		0.45 REF	
b	0.32	--	0.42
D		6 BSC	
E		7 BSC	
e		0.75 BSC	
D1		3.75 BSC	
E1		5.25 BSC	

NOTES.

- 1). DIMENSION b IS MEASURED AT THE MAXIMUM SOLDER BALL DIAMETER, PARALLEL TO DATUM PLANE Z.
- 2). DATUM Z (SEATING PLANE) IS DEFINED BY THE SPHERICAL CROWNS OF THE SOLDER BALLS.
- 3). PARALLELISM MEASUREMENT SHALL EXCLUDE ANY EFFECT OF MARK ON TOP SURFACE OF PACKAGE.



256K X 16 BIT LOW POWER CMOS SRAM

Ordering Information

Alliance	Organization	VCC Range	Package	Operating Temp	Speed ns
AS6C4016A-45ZIN	256K x 16	2.7 ~ 3.6V	44-TSOP2	Industrial (-40 ~ 85°C)	45
AS6C4016A-45BIN	256K x 16	2.7 ~ 3.6V	VFBGA-48	Industrial (-40 ~ 85°C)	45

Part Numbering System

AS6C	4016A	-45	X	X	N
low power SRAM prefix	Device Number 40 = 4M 16 = x16	Access Time	Package Option 44pin TSOP II 48ball TFBGA	Temperature Range I = Industrial (-40 to + 85°C)	N = Lead Free RoHS compliant part



Стандарт Электрон Связь

Мы молодая и активно развивающаяся компания в области поставок электронных компонентов. Мы поставляем электронные компоненты отечественного и импортного производства напрямую от производителей и с крупнейших складов мира.

Благодаря сотрудничеству с мировыми поставщиками мы осуществляем комплексные и плановые поставки широчайшего спектра электронных компонентов.

Собственная эффективная логистика и склад в обеспечивает надежную поставку продукции в точно указанные сроки по всей России.

Мы осуществляем техническую поддержку нашим клиентам и предпродажную проверку качества продукции. На все поставляемые продукты мы предоставляем гарантию .

Осуществляем поставки продукции под контролем ВП МО РФ на предприятия военно-промышленного комплекса России , а также работаем в рамках 275 ФЗ с открытием отдельных счетов в уполномоченном банке. Система менеджмента качества компании соответствует требованиям ГОСТ ISO 9001.

Минимальные сроки поставки, гибкие цены, неограниченный ассортимент и индивидуальный подход к клиентам являются основой для выстраивания долгосрочного и эффективного сотрудничества с предприятиями радиоэлектронной промышленности, предприятиями ВПК и научно-исследовательскими институтами России.

С нами вы становитесь еще успешнее!

Наши контакты:

Телефон: +7 812 627 14 35

Электронная почта: sales@st-electron.ru

Адрес: 198099, Санкт-Петербург,
Промышленная ул, дом № 19, литера Н,
помещение 100-Н Офис 331