

# PINFET

## optical receiver modules

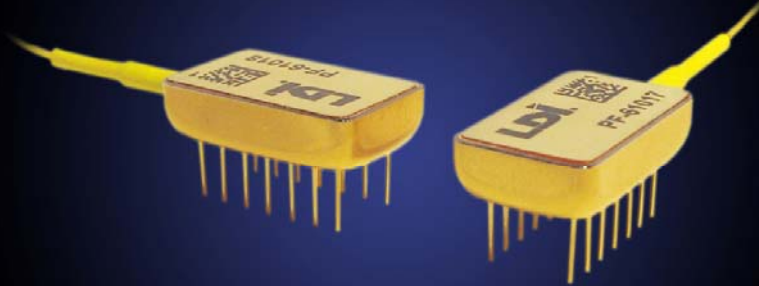

- GR-468-CORE Telcordia Qualified
- High Sensitivity
- High Overload Power
- Wide Dynamic Range
- 850, 1310, 1550nm Operation
- Hermetic Package – Industry Standard 14 Pin DIP Package
- Custom MIL or IEC Screening

*Introducing LDFR Series with Single Supply Option!*

The Laser Diode Inc. PINFET provides an excellent solution for optical receiver systems that require both high sensitivity and wide dynamic range. Applications include telecommunications line-terminating equipment or repeaters and optical sensor systems. The receiver package offers high reliability satisfying Telcordia specifications.

### Specifications and Limits

#### Performance @ 25°C (+/- 5.0 VDC)

		Minimum <sup>1</sup> Bandwidth (MHz)	Suggested <sup>2</sup> Data Rate (Mb/s)	Sensitivity <sup>3</sup> (dBm)		Dynamic Range (dB) typ	Trans- impedance (Kohms)
				max	typ		
<b>LDPF Series</b>  (non-AGC)	LDPF 0004	4	6	-54	-56	25	1100
	LDPF 0012	12	17	-51	-53	25	740
	LDPF 0024	24	34	-48	-50	25	340
	LDPF 0032	32	45	-47	-49	25	210
	LDPF 0065	65	90	-43	-45	25	80
	LDPF 0120	120	168	-40	-42	25	40
LDPF 0250	250	350	-35	-37	25	10	
<b>LDPW Series</b>  (AGC)	LDPW 0003	3	4	-54	-56	53	1100
	LDPW 0012	12	17	-50	-52	49	350
	LDPW 0024	24	34	-48	-50	47	340
	LDPW 0036	36	52	-46	-48	45	210
	LDPW 0065	65	90	-41	-43	40	60
	LDPW 0110	110	155	-38	-40	37	30
<b>LDSF Series</b>  (non-AGC)	LDSF 0004	4	6	-51	-53	25	1100
	LDSF 0012	12	17	-48	-50	25	740
	LDSF 0024	24	34	-45	-47	25	340
	LDSF 0032	32	45	-44	-46	25	210
	LDSF 0065	65	90	-40	-42	25	80
	LDSF 0120	120	168	-37	-39	25	40
	LDSF 0250	250	350	-32	-34	25	10
		Minimum <sup>1</sup> Bandwidth (MHz)	NEIP pW/SqRt Hz typ	Sensitivity <sup>3</sup> (dBm)		Dynamic Range (dB) typ	Trans- impedance (Kohms)
				max	typ		
<b>LDFR Series</b> (non-AGC)	LDFR 0850R	5	0.30	-52	-54	25	940
	LDFR 1550R	5	0.25	-54	-56	25	940

# Common Characteristics @ 25°C

		LDSF & LDPF Series			LDPW Series			LDFR Series			
		min	typ	max	min	typ	max	min	typ	max	
Dark Current @ -5V	nA		0.5	1		0.5	1		0.5	1	
Maximum Optical Input @ -5V	dBm		Sensitivity Level (dBm) +25dB			-3	0		Sensitivity Level (dBm) +25dB		
Sensitivity Derating Over Temperature	dB		<1			<1			<1		
Detector Responsivity	A/W										
850nm			.5					0.6	0.65		
1300nm			0.9			0.9					
1550nm			0.95			0.95		0.9	0.95		
Maximum Output Signal Level	V <sub>pp</sub>		2.5			0.8			3.0		
Output Impedance	Ohms		10			10			10		
Load Impedance	Ohms		1000			1000			1000		
Supply Voltage	V	4.5		5.5	4.5		5.5	4.75		5.25	
Power Supply Current +5V	mA		25	35		25	35		20		
Power Supply Current -5V	mA		10	15		10	15		-		
Fiber - MM Tight Buffer	um	50/125/245/900			50/125/245/900			50/125/245/900			

## Absolute Maximum Ratings

	Units	LDPF, LDPW & LDSF Series	LDFR Series
Operating Temperature	°C	-40 to +70	-55 to +85
Storage Temperature	°C	-40 to +85	-55 to +85
Positive Supply Voltage	V	+7	+7
Negative Supply Voltage	V	-7	-
Detector Bias	V	-10	-10
Soldering time at 260°C	secs	10	10

## Notes:

- Bandwidth is measured at the -3dB point.
- A given bandwidth will typically support an NRZ data rate of 1.4 times the 3dB bandwidth.
- Sensitivity is calculated using the noise voltage measured at 25°C at the output of a 3-pole Butterworth filter whose bandwidth equals that of the PINFET's minimum specified bandwidth. Sensitivity is specified as the average optical power in dBm measured at 1300nm and T<sub>a</sub> = 25°C for a BER of 10<sup>-9</sup>.

## Outline Drawing

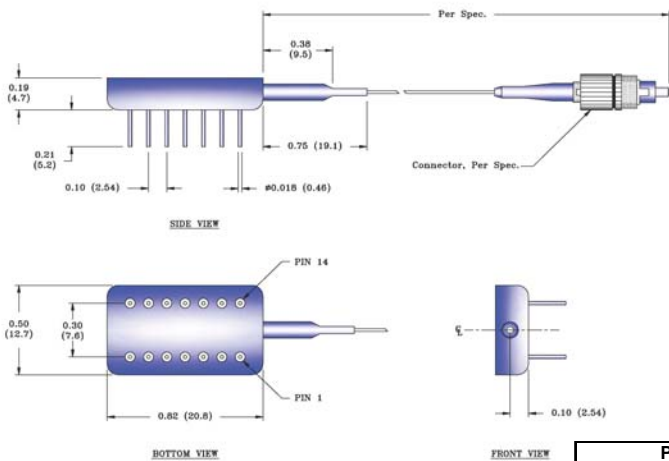

Detailed package drawings are available upon request.

Pin Assignments	
Pin	Function
1	-5 V detector bias
2,6,9,11	no connection
12,13,14	no connection
3,5,8	ground
4	-5 volts (LDFR = NC)
7	output
10	+5 volts

## Part Numbering Diagram

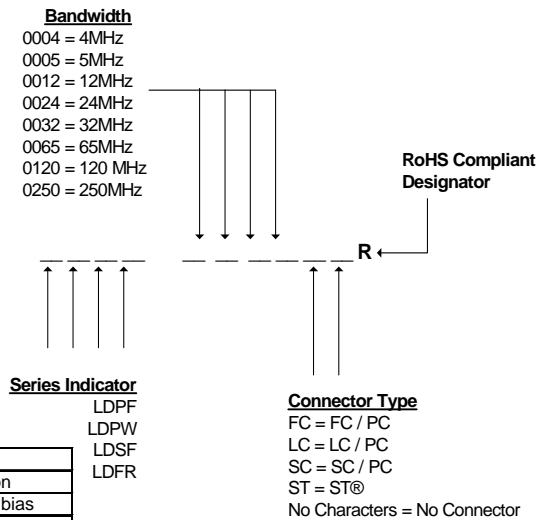

Products can be ordered directly from Laser Diode Inc. or its representatives. When ordering, refer to the numbering diagram above. For a complete listing of representatives, visit our website at [www.laserdiode.com](http://www.laserdiode.com)

### Personal Hazard and Handling Precautions:

Handle optical fiber with normal care, avoiding stretch, tension, twist, kink or bend abuse. ESD precautions apply.

### Warranty:

Please refer to your product purchase agreement for complete details or check with your Laser Diode sales representative.

### Notice:

Laser Diode Inc. reserves the right to make changes to the products or information contained herein without notice. No liability is assumed as a result of their use or application.



## Стандарт Электрон Связь

Мы молодая и активно развивающаяся компания в области поставок электронных компонентов. Мы поставляем электронные компоненты отечественного и импортного производства напрямую от производителей и с крупнейших складов мира.

Благодаря сотрудничеству с мировыми поставщиками мы осуществляем комплексные и плановые поставки широчайшего спектра электронных компонентов.

Собственная эффективная логистика и склад в обеспечивает надежную поставку продукции в точно указанные сроки по всей России.

Мы осуществляем техническую поддержку нашим клиентам и предпродажную проверку качества продукции. На все поставляемые продукты мы предоставляем гарантию .

Осуществляем поставки продукции под контролем ВП МО РФ на предприятия военно-промышленного комплекса России , а также работаем в рамках 275 ФЗ с открытием отдельных счетов в уполномоченном банке. Система менеджмента качества компании соответствует требованиям ГОСТ ISO 9001.

Минимальные сроки поставки, гибкие цены, неограниченный ассортимент и индивидуальный подход к клиентам являются основой для выстраивания долгосрочного и эффективного сотрудничества с предприятиями радиоэлектронной промышленности, предприятиями ВПК и научно-исследовательскими институтами России.

С нами вы становитесь еще успешнее!

### Наши контакты:

**Телефон:** +7 812 627 14 35

**Электронная почта:** [sales@st-electron.ru](mailto:sales@st-electron.ru)

**Адрес:** 198099, Санкт-Петербург,  
Промышленная ул, дом № 19, литера Н,  
помещение 100-Н Офис 331