

Marketing Bulletin

DATE: January 5, 2004
TO: Affected Customers
FROM: Mark Stoner
RE: Product Termination

To all concerned parties,

This bulletin is to notify all customers of the termination of the following Ecliptek series effective November 11th, 2003:

Series	Description	Recommended Replacement
EC51	5V 14 Pin DIP TCXO, HCMOS	EB51F3
ES51	5V 14 Pin DIP TCXO, Sinewave	ES51F3
EC53	3.3V 14 Pin DIP TCXO, HCMOS	EB52F3

In compliance with our End of Life (EOL) policy, this will serve as advanced notice of product termination. New orders will not be accepted after February 1st, 2004, with deliveries to conclude by July 1st 2004.

If there are any questions pertaining to this bulletin, please feel free to contact me.
Thank you for your cooperation.

Best Regards,

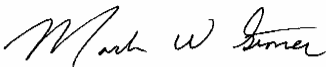

Mark W. Stoner
Director of Marketing
Ecliptek Corporation

STANDARD SPECIFICATIONS

Frequency Range:	9.600MHz to 35.000MHz
Frequency Stability: vs. Input Voltage ($\pm 5\%$) vs. Load ($\pm 2k\Omega/\pm 2pF$) vs. Aging (at 25°C)	See Table 1 for Maximum Values (Inclusive of Operating Temperature Range) $\pm 0.3ppm$ Maximum $\pm 0.3ppm$ Maximum $\pm 1ppm/year$ Maximum
Operating/Storage Temp. Range	See Table 1 for Operating Temperature Range / Storage -40°C to +85°C
Supply Voltage	5.0Vdc $\pm 5\%$
Input Current	1.5mA Max. $\leq 20.000MHz$, 2.0mA Max. $20.001MHz$ to $29.999MHz$, 3.0mA Max. $\geq 30.000MHz$
Output Voltage	1.0Vp-p Minimum
Load Drive Capability	10kOhms // 10pF
Internal Trim (Top of Can)	$\pm 3ppm$ Minimum
Pin 1 Control Voltage Blank V	No Connect (Pin 1 not present) 2.5Vdc $\pm 2.0Vdc$, Positive Transfer Characteristic
Frequency Deviation	$\pm 5ppm$ Minimum over Control Voltage
Typical Phase Noise	-85dBc/Hz at 10Hz Offset, -115dBc/Hz at 100Hz Offset, -135dBc/Hz at 1kHz Offset, -140dBc/Hz at 10kHz Offset, -145dBc/Hz at 100kHz Offset, -150dBc/Hz at 1MHz Offset

OBSOLETE

ENVIRONMENTAL & MECHANICAL

Fine Leak Test:	MIL-STD-883, Method 1014, Condition A	Solderability:	MIL-STD-883, Method 2002
Gross Leak Test:	MIL-STD-883, Method 1014, Condition C	Temperature Cycling:	MIL-STD-883, Method 1010
Mechanical Shock:	MIL-STD-202, Method 213, Condition C	Resistance to Soldering Heat:	MIL-STD-202, Method 210
Vibration:	MIL-STD-883, Method 2007, Condition A	Resistance to Solvents:	MIL-STD-202, Method 215
Lead Integrity:	MIL-STD-883, Method 2004		

TABLE 1: PART NUMBERING CODES

OPERATING TEMPERATURE		FREQUENCY STABILITY						Code
		15	20	25	30	35	50	
		X Denotes availability from 9.600MHz to 25.000MHz Y Denotes availability for any valid frequency.						
Range	Code	$\pm 1.5ppm$	$\pm 2.0ppm$	$\pm 2.5ppm$	$\pm 3.0ppm$	$\pm 3.5ppm$	$\pm 5.0ppm$	Range
0°C to +50°C	A	Y	Y	Y	Y	Y	Y	
-10°C to +60°C	B	Y	Y	Y	Y	Y	Y	
-20°C to +70°C	C	X	Y	Y	Y	Y	Y	
-30°C to +60°C	D		X	Y	Y	Y	Y	
-30°C to +75°C	E		X	X	Y	Y	Y	
-35°C to +80°C	F			X	X	Y	Y	
-40°C to +85°C	G				X	X	Y	

MARKING GUIDE

(Line #1) **ECLIPTEK**

(Line #2) **ES51 00 X Y**

Pin 1 Connection
 Blank = No Connect (pin 1 not present)
 V = Control Voltage 2.5Vdc $\pm 2.0Vdc$
 Positive Transfer Characteristic
Operating Temperature
 Code Per Table 1
Frequency Stability
 Code Per Table 1

PART NUMBERING GUIDE

ES51 25 E V - 12.800M

Frequency
Pin 1 Connection
 Blank = No Connect (pin 1 not present)
 V = Voltage Control
Operating Temperature Range Code Per Table 1
Frequency Stability Code Per Table 1

(Line #3) **XX.XXXM**

Frequency

(Line #4) **XX Y ZZ**

Week of Year
Last Digit of Year
 Eclipsetek Manufacturing Code

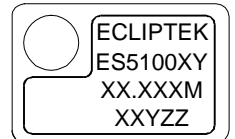

NOTE: Marking shall conform to conditions listed in TQC41-001-000.

SPECIFICATION CONTROL DRAWING

		Drawing Number CSC06-020-000	
Title 4.5mm HEIGHT THRU-HOLE SINEWAVE TCXO			
Revision E		Effectivity Date 05-02-03	
ECN Number 8396		PAGE 1 OF 2	
Approved By	Date	Released By	Date

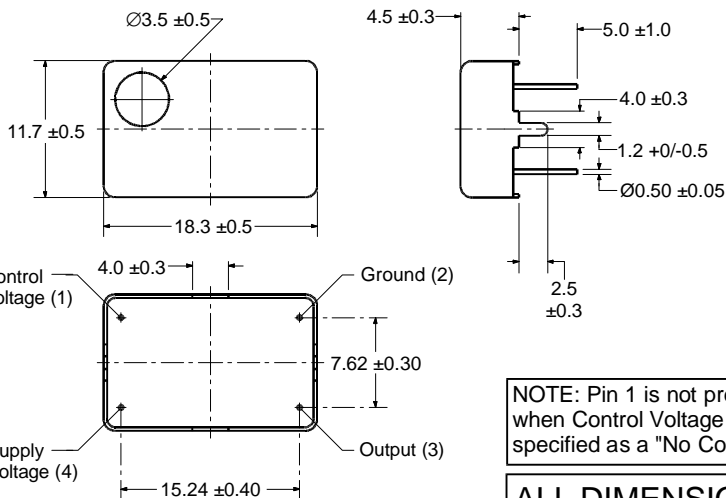

NOTE: Pin 1 is not present when Control Voltage is specified as a "No Connect"

ALL DIMENSIONS IN MILLIMETERS

STANDARD SPECIFICATIONS

Frequency Range:	9.600MHz to 35.000MHz
Frequency Stability: vs. Input Voltage ($\pm 5\%$) vs. Load ($\pm 2\text{pF}$) vs. Aging (at 25°C)	See Table 1 for Maximum Values (Inclusive of Operating Temperature Range) $\pm 0.3\text{ppm}$ Maximum $\pm 0.3\text{ppm}$ Maximum $\pm 1\text{ppm/year}$ Maximum
Operating/Storage Temp. Range	See Table 1 for Operating Temperature Range / Storage -40°C to +85°C
Supply Voltage	5.0Vdc $\pm 5\%$
Input Current	30mA Maximum
Output Voltage Logic High	2.4Vdc Min. w/TTL Load, VDD-0.5Vdc Min. w/HCMOS Load
Output Voltage Logic Low	0.4Vdc Max. w/TTL Load, 0.5Vdc Max. w/HCMOS Load
Rise/Fall Time	10nSec (0.4Vdc to 2.4Vdc w/TTL Load, 20% to 80% of waveform w/HCMOS Load)
Duty Cycle	50% $\pm 10\%$ (@ 1.4Vdc w/TTL Load, @ 50% of waveform w/HCMOS Load)
Load Drive Capability	10TTL Load or 15pF HCMOS Load Maximum
Internal Trim (Top of Can)	$\pm 3\text{ppm}$ Minimum
Pin 1 Control Voltage Blank V	No Connect (Pin 1 not present) 2.5Vdc $\pm 2.0\text{Vdc}$, Positive Transfer Characteristic
Frequency Deviation	$\pm 5\text{ppm}$ Minimum over Control Voltage
Typical Phase Noise	-85dBc/Hz at 10Hz Offset, -115dBc/Hz at 100Hz Offset, -135dBc/Hz at 1kHz Offset, -140dBc/Hz at 10kHz Offset, -145dBc/Hz at 100kHz Offset, -150dBc/Hz at 1MHz Offset

OBSOLETE

ENVIRONMENTAL & MECHANICAL

Fine Leak Test:	MIL-STD-883, Method 1014, Condition A	Solderability:	MIL-STD-883, Method 2002
Gross Leak Test:	MIL-STD-883, Method 1014, Condition C	Temperature Cycling:	MIL-STD-883, Method 1010
Mechanical Shock:	MIL-STD-202, Method 213, Condition C	Resistance to Soldering Heat:	MIL-STD-202, Method 210
Vibration:	MIL-STD-883, Method 2007, Condition A	Resistance to Solvents:	MIL-STD-202, Method 215
Lead Integrity:	MIL-STD-883, Method 2004		

TABLE 1: PART NUMBERING CODES

OPERATING TEMPERATURE		FREQUENCY STABILITY						
		15	20	25	30	35	50	Code
		X Denotes availability from 9.600MHz to 25.000MHz Y Denotes availability for any valid frequency.						
Range	Code	$\pm 1.5\text{ppm}$	$\pm 2.0\text{ppm}$	$\pm 2.5\text{ppm}$	$\pm 3.0\text{ppm}$	$\pm 3.5\text{ppm}$	$\pm 5.0\text{ppm}$	Range
0°C to +50°C	A	Y	Y	Y	Y	Y	Y	
-10°C to +60°C	B	Y	Y	Y	Y	Y	Y	
-20°C to +70°C	C	X	Y	Y	Y	Y	Y	
-30°C to +60°C	D		X	Y	Y	Y	Y	
-30°C to +75°C	E		X	X	Y	Y	Y	
-35°C to +80°C	F			X	X	Y	Y	
-40°C to +85°C	G				X	X	Y	

MARKING GUIDE

(Line #1) **ECLIPTEK**

(Line #2) **EC51 00 X Y**

Pin 1 Connection
Blank = No Connect (pin 1 not present)
V = Control Voltage 2.5Vdc $\pm 2.0\text{Vdc}$
Positive Transfer Characteristic

Operating Temperature
Code Per Table 1

Frequency Stability
Code Per Table 1

(Line #3) **XX.XXXM**

Frequency

(Line #4) **XX Y ZZ**

Week of Year
Last Digit of Year

Ecliptek Manufacturing Code

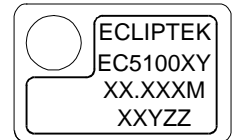

PART NUMBERING GUIDE

EC51 25 E V - 12.800M

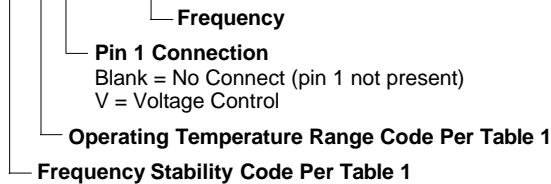

NOTE: Marking shall conform to conditions listed in TQC41-001-000.

SPECIFICATION CONTROL DRAWING

		Drawing Number CSC06-010-000	
Title 4.5mm HEIGHT THRU-HOLE HCMOS/TTL TCXO			
Revision E		Effectivity Date 05-02-03	
ECN Number 8395		PAGE 1 OF 2	
Approved By	Date	Released By	Date

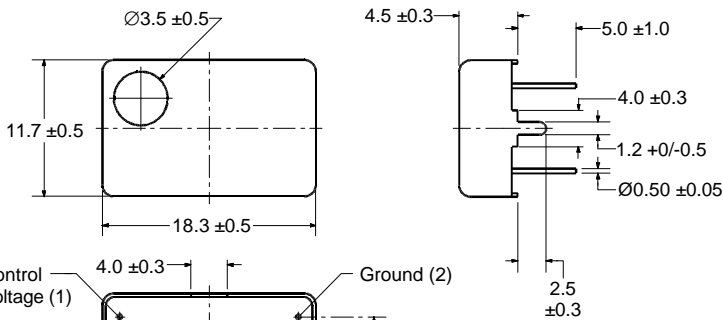

NOTE: Pin 1 is not present when Control Voltage is specified as a "No Connect"

ALL DIMENSIONS IN MILLIMETERS

STANDARD SPECIFICATIONS

Frequency Range:	9.600MHz to 35.000MHz
Frequency Stability: vs. Input Voltage ($\pm 5\%$) vs. Load ($\pm 2\text{pF}$) vs. Aging (at 25°C)	See Table 1 for Maximum Values (Inclusive of Operating Temperature Range) $\pm 0.3\text{ppm}$ Maximum $\pm 0.3\text{ppm}$ Maximum $\pm 1\text{ppm/year}$ Maximum
Operating/Storage Temp. Range	See Table 1 for Operating Temperature Range / Storage -40°C to +85°C
Supply Voltage	3.3Vdc $\pm 5\%$
Input Current	10mA Maximum $\leq 20.000\text{MHz}$, 20mA Maximum $> 20.000\text{MHz}$
Output Voltage Logic High	2.7Vdc Minimum
Output Voltage Logic Low	0.5Vdc Maximum
Rise/Fall Time	10nSec. Maximum (20% to 80% of waveform)
Duty Cycle	50% $\pm 10\%$ (@50% of waveform)
Load Drive Capability	15pF HCMOS Load Maximum
Internal Trim (Top of Can)	$\pm 3\text{ppm}$ Minimum
Pin 1 Control Voltage Blank V	No Connect (Pin 1 not present) 1.65Vdc $\pm 1.35\text{Vdc}$, Positive Transfer Characteristic
Frequency Deviation	$\pm 5\text{ppm}$ Minimum over Control Voltage
Typical Phase Noise	-85dBc/Hz at 10Hz Offset, -115dBc/Hz at 100Hz Offset, -135dBc/Hz at 1kHz Offset, -140dBc/Hz at 10kHz Offset, -145dBc/Hz at 100kHz Offset, -150dBc/Hz at 1MHz Offset

OBSOLETE

ENVIRONMENTAL & MECHANICAL

Fine Leak Test:	MIL-STD-883, Method 1014, Condition A	Solderability:	MIL-STD-883, Method 2002
Gross Leak Test:	MIL-STD-883, Method 1014, Condition C	Temperature Cycling:	MIL-STD-883, Method 1010
Mechanical Shock:	MIL-STD-202, Method 213, Condition C	Resistance to Soldering Heat:	MIL-STD-202, Method 210
Vibration:	MIL-STD-883, Method 2007, Condition A	Resistance to Solvents:	MIL-STD-202, Method 215
Lead Integrity:	MIL-STD-883, Method 2004		

TABLE 1: PART NUMBERING CODES

OPERATING TEMPERATURE		FREQUENCY STABILITY						
		X Denotes availability from 9.600MHz to 25.000MHz Y Denotes availability for any valid frequency.						
Range	Code	15 $\pm 1.5\text{ppm}$	20 $\pm 2.0\text{ppm}$	25 $\pm 2.5\text{ppm}$	30 $\pm 3.0\text{ppm}$	35 $\pm 3.5\text{ppm}$	50 $\pm 5.0\text{ppm}$	Code Range
0°C to +50°C	A	Y	Y	Y	Y	Y	Y	
-10°C to +60°C	B	Y	Y	Y	Y	Y	Y	
-20°C to +70°C	C	X	Y	Y	Y	Y	Y	
-30°C to +60°C	D		X	Y	Y	Y	Y	
-30°C to +75°C	E		X	X	Y	Y	Y	
-35°C to +80°C	F			X	X	Y	Y	
-40°C to +85°C	G				X	X	Y	

MARKING GUIDE

(Line #1) **ECLIPTEK**

(Line #2) **EC53 00 X Y**

Pin 1 Connection
Blank = No Connect (pin 1 not present)
V = Control Voltage 1.65Vdc $\pm 1.35\text{Vdc}$
Positive Transfer Characteristic

Operating Temperature
Code Per Table 1

Frequency Stability
Code Per Table 1

PART NUMBERING GUIDE

EC53 25 E V - 12.800M

Frequency

Pin 1 Connection
Blank = No Connect (pin 1 not present)
V = Voltage Control

Operating Temperature Range Code Per Table 1

Frequency Stability Code Per Table 1

(Line #3) **XX.XXXM**

Frequency

(Line #4) **XX Y ZZ**

Week of Year
Last Digit of Year

Ecliptek Manufacturing Code (Per TEN02-001-000)

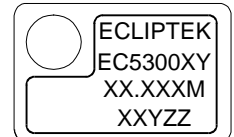

NOTE: Marking shall conform to conditions listed in TQC41-001-000.

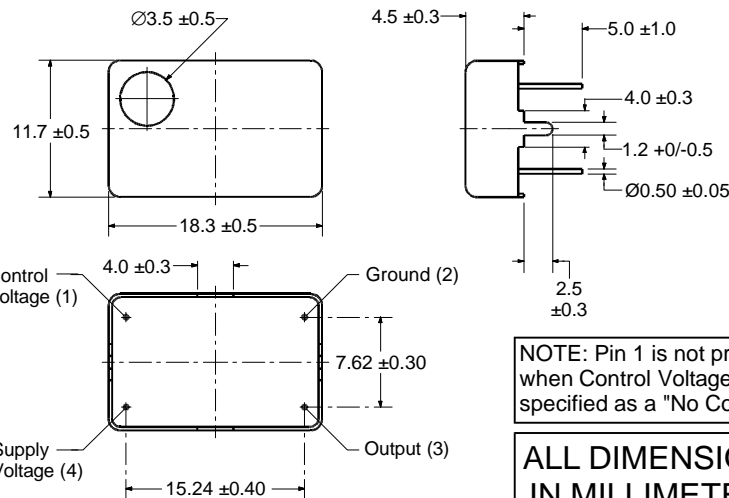

NOTE: Pin 1 is not present when Control Voltage is specified as a "No Connect"

ALL DIMENSIONS IN MILLIMETERS

CLASS/SUBCLASS: OS62

SPECIFICATION CONTROL DRAWING

	Drawing Number CSC06-110-000
Title 4.5mm THRU-HOLE 3.3Vdc HCMOS/TTL TCXO	
Revision C	Effectivity Date 05-02-03
ECN Number 8400	PAGE 1 OF 2
Approved By	Date
Released By	Date



Стандарт Электрон Связь

Мы молодая и активно развивающаяся компания в области поставок электронных компонентов. Мы поставляем электронные компоненты отечественного и импортного производства напрямую от производителей и с крупнейших складов мира.

Благодаря сотрудничеству с мировыми поставщиками мы осуществляем комплексные и плановые поставки широчайшего спектра электронных компонентов.

Собственная эффективная логистика и склад в обеспечивает надежную поставку продукции в точно указанные сроки по всей России.

Мы осуществляем техническую поддержку нашим клиентам и предпродажную проверку качества продукции. На все поставляемые продукты мы предоставляем гарантию .

Осуществляем поставки продукции под контролем ВП МО РФ на предприятия военно-промышленного комплекса России , а также работаем в рамках 275 ФЗ с открытием отдельных счетов в уполномоченном банке. Система менеджмента качества компании соответствует требованиям ГОСТ ISO 9001.

Минимальные сроки поставки, гибкие цены, неограниченный ассортимент и индивидуальный подход к клиентам являются основой для выстраивания долгосрочного и эффективного сотрудничества с предприятиями радиоэлектронной промышленности, предприятиями ВПК и научно-исследовательскими институтами России.

С нами вы становитесь еще успешнее!

Наши контакты:

Телефон: +7 812 627 14 35

Электронная почта: sales@st-electron.ru

Адрес: 198099, Санкт-Петербург,
Промышленная ул, дом № 19, литера Н,
помещение 100-Н Офис 331