



16W Single Output LED Power Supply

PLD-16 series



■ Features :

- 115VAC or 230VAC models available
- Built-in active PFC function
- Constant current design
- Protections: Short circuit / Over temperature
- Cooling by free air convection
- Fully isolated plastic case
- Class 2 Power Unit
- Class II power unit, no FG
- IP30 design
- Suitable for indoor LED lighting applications
- 100% full load burn-in test
- Low cost
- High reliability
- 3 years warranty



PLD-16-350 A : With AC input 90~ 135VAC.
 B : With AC input 180~ 295VAC.

SPECIFICATION

MODEL	PLD-16-350 <input type="checkbox"/>	PLD-16-700 <input type="checkbox"/>	PLD-16-1050 <input type="checkbox"/>	PLD-16-1400 <input type="checkbox"/>	
OUTPUT	RATED CURRENT	350mA	700mA	1050mA	1400mA
	OPERATING VOLTAGE RANGE	24 ~ 48V	16 ~ 24V	12 ~ 16V	8 ~ 12V
	CURRENT ACCURACY	±5.0%			
	RATED POWER	16.8W	16.8W	16.8W	16.8W
	RIPPLE & NOISE (max.) Note.1	4.6Vp-p	2.7Vp-p	2.2Vp-p	2Vp-p
	NO LOAD OUTPUT VOLTAGE (max.)	60V	35V	25V	16V
	SETUP TIME	500ms / 230VAC 2000ms / 115VAC at full load			
INPUT	FREQUENCY RANGE	47 ~ 63Hz			
	POWER FACTOR (Typ.)	PF>0.9/115VAC, PF>0.9/230VAC, PF>0.9/277VAC at full load (Please refer to "Power Factor Characteristic" curve)			
	TOTAL HARMONIC DISTORTION	A series	THD< 20% when output loading≥70% at 115VAC		
		B series	THD< 20% when output loading≥80% at 230VAC input and output loading≥80% at 277VAC input		
	EFFICIENCY (Typ.)	A series	84.5%	84%	82.5%
		B series	85.5%	86%	83.5%
	AC CURRENT (Typ.)	0.4A/115VAC	0.2A/230VAC	0.15A/277VAC	
	INRUSH CURRENT(Typ.)	COLD START 20A(twidth=25µs measured at 50% Ipeak) at 230VAC			
MAX. No. of PSUs on 16A CIRCUIT BREAKER	A series	58 units (circuit breaker of type B) / 58 units (circuit breaker of type C) at 115VAC			
	B series	128 units (circuit breaker of type B) / 128 units (circuit breaker of type C) at 230VAC			
LEAKAGE CURRENT	<0.5mA / 240VAC				
PROTECTION	SHORT CIRCUIT	Hiccup mode, recovers automatically after fault condition is removed.			
	OVER TEMPERATURE	Shut down o/p voltage, re-power on to recover			
ENVIRONMENT	WORKING TEMP.	-30 ~ +50°C (Refer to "Derating Curve")			
	WORKING HUMIDITY	20 ~ 95% RH non-condensing			
	STORAGE TEMP., HUMIDITY	-40 ~ +80°C, 10 ~ 95% RH			
	TEMP. COEFFICIENT	±0.03%/°C (0 ~ 50°C)			
	VIBRATION	10 ~ 500Hz, 2G 12min./1cycle, period for 72min. each along X, Y, Z axes			
SAFETY & EMC	SAFETY STANDARDS	UL 8750, CSA C22.2 No.250.0-08(except for PLD-16-350);ENEC EN 613471-1,EN 61347-2-13 independent, EN62384(for B type only)approved			
	WITHSTAND VOLTAGE	I/P-O/P:3.75KVAC			
	ISOLATION RESISTANCE	I/P-O/P:100M Ohms / 500VDC / 25°C/ 70% RH			
	EMC EMISSION	Compliance to EN55015 (B type only), EN61000-3-2 Class C ; EN61000-3-3, FCC part 18 non-consumer equipment(A type only)			
	EMC IMMUNITY	Compliance to EN61000-4-2,3,4,5,6,8,11, EN61547, light industry level, criteria A			
OTHERS	MTBF	906.5Khrs min. MIL-HDBK-217F (25°C)			
	DIMENSION	84*57*29.5mm (L*W*H)			
	PACKING	0.19Kg; 72pcs/14.7Kg/0.92CUFT			
NOTE	1. Ripple & noise are measured at 20MHz of bandwidth by using a 12" twisted pair-wire terminated with a 0.1uf & 47uf parallel capacitor. 2. Direct connecting to LEDs is suggested, but is not suitable for using additional drivers. 3. To fulfill requirements of the latest ErP regulation for lighting fixtures, this LED power supply can only be used behind a switch without permanently connected to the mains.				

Mechanical Specification

Case No. PCD16A Unit: mm

A Type: (PLD-16_A)

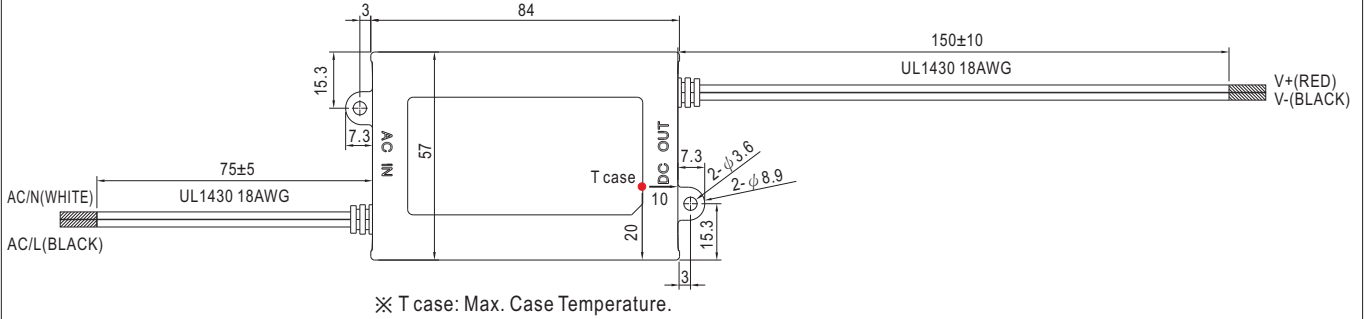

B Type: (PLD-16_B)

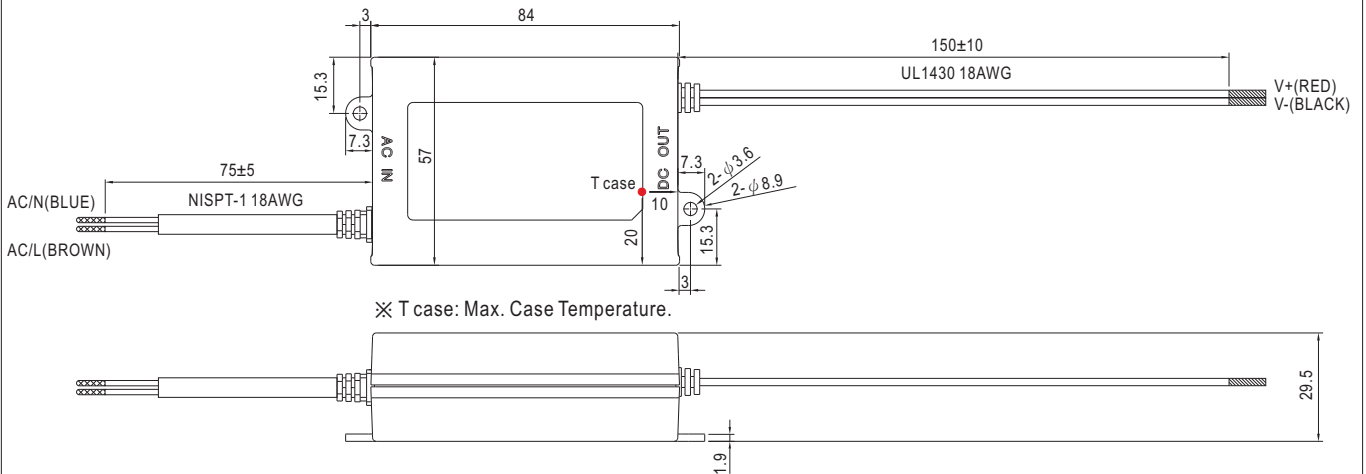

Block Diagram

fosc : 90KHz(115VAC)
120KHz(230VAC)

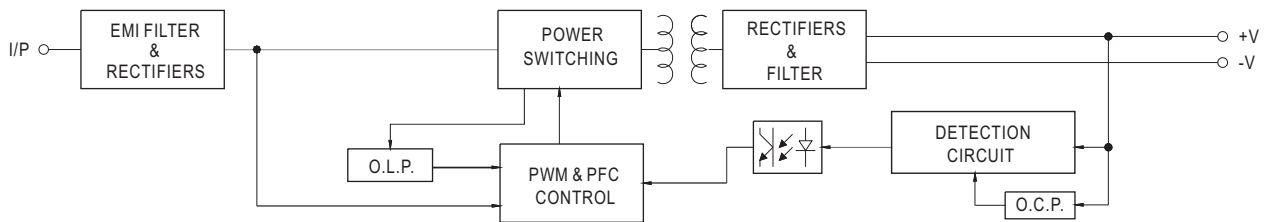

■ Derating Curve

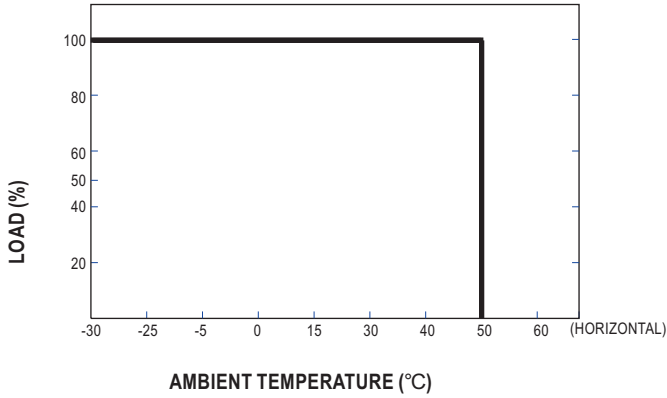

■ Static Characteristics

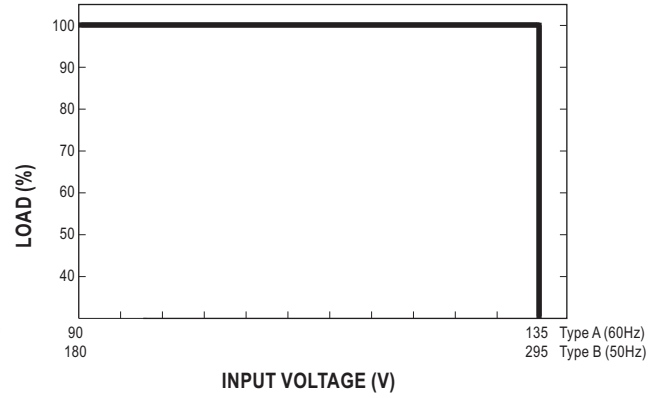

■ Power Factor Characteristic

Constant Current Mode

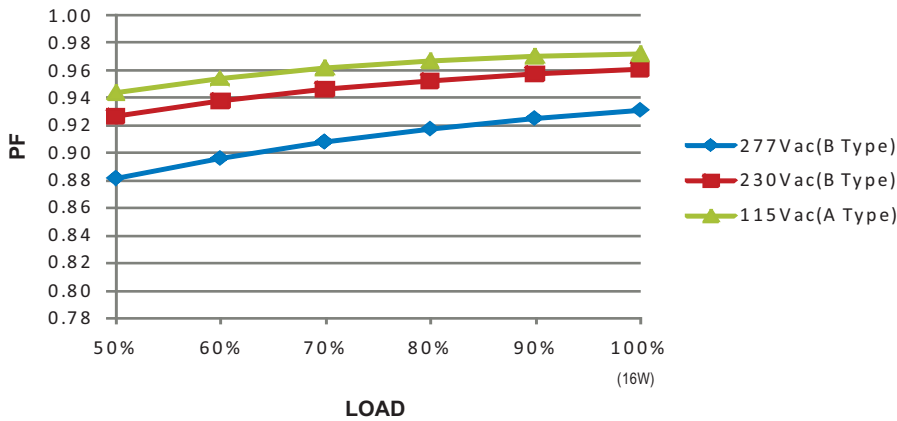

■ EFFICIENCY vs LOAD (PLD-16-350)

PLD-16 series possess superior working efficiency that up to 85.5% can be reached in field applications.

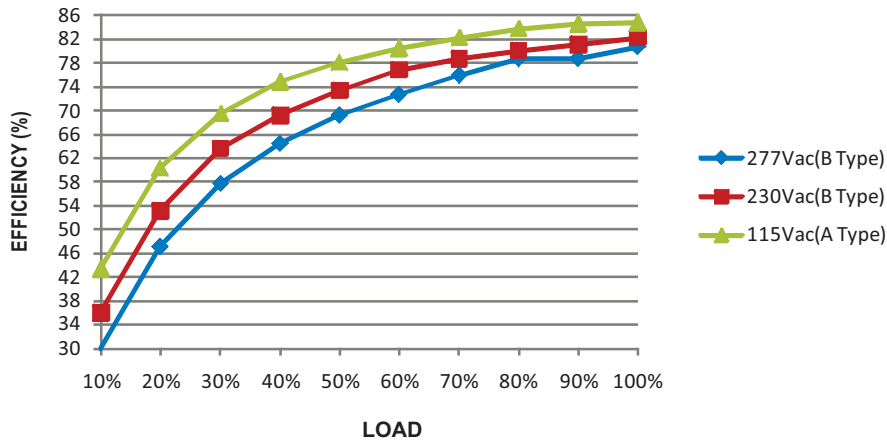



Стандарт Электрон Связь

Мы молодая и активно развивающаяся компания в области поставок электронных компонентов. Мы поставляем электронные компоненты отечественного и импортного производства напрямую от производителей и с крупнейших складов мира.

Благодаря сотрудничеству с мировыми поставщиками мы осуществляем комплексные и плановые поставки широчайшего спектра электронных компонентов.

Собственная эффективная логистика и склад в обеспечивает надежную поставку продукции в точно указанные сроки по всей России.

Мы осуществляем техническую поддержку нашим клиентам и предпродажную проверку качества продукции. На все поставляемые продукты мы предоставляем гарантию .

Осуществляем поставки продукции под контролем ВП МО РФ на предприятия военно-промышленного комплекса России , а также работаем в рамках 275 ФЗ с открытием отдельных счетов в уполномоченном банке. Система менеджмента качества компании соответствует требованиям ГОСТ ISO 9001.

Минимальные сроки поставки, гибкие цены, неограниченный ассортимент и индивидуальный подход к клиентам являются основой для выстраивания долгосрочного и эффективного сотрудничества с предприятиями радиоэлектронной промышленности, предприятиями ВПК и научно-исследовательскими институтами России.

С нами вы становитесь еще успешнее!

Наши контакты:

Телефон: +7 812 627 14 35

Электронная почта: sales@st-electron.ru

Адрес: 198099, Санкт-Петербург,
Промышленная ул, дом № 19, литера Н,
помещение 100-Н Офис 331