

PRODUCT NUMBER	DESCRIPTION	NOTES
10117949-XXXXLF	NON-HF	SEE SHT. 3
10117949-XXXXHLF	HALOGEN FREE (H)	SEE SHT. 3

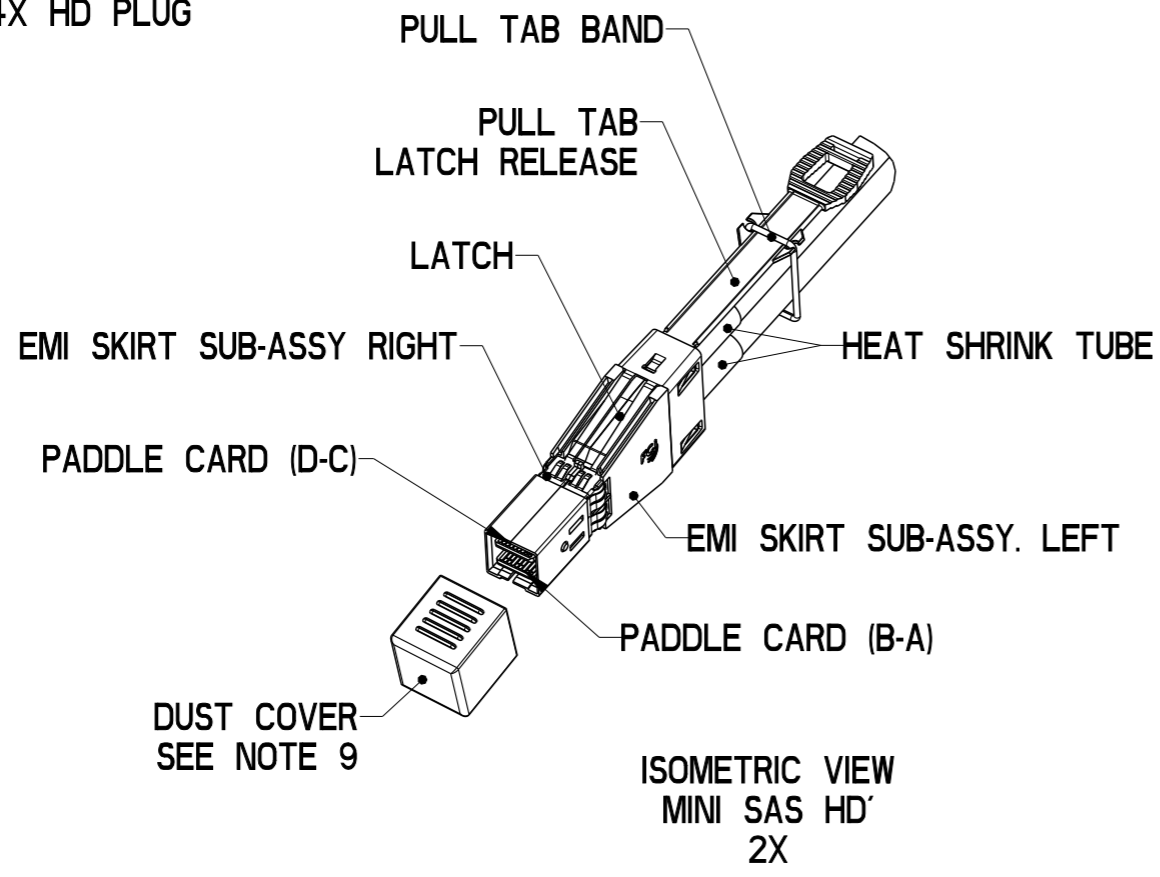
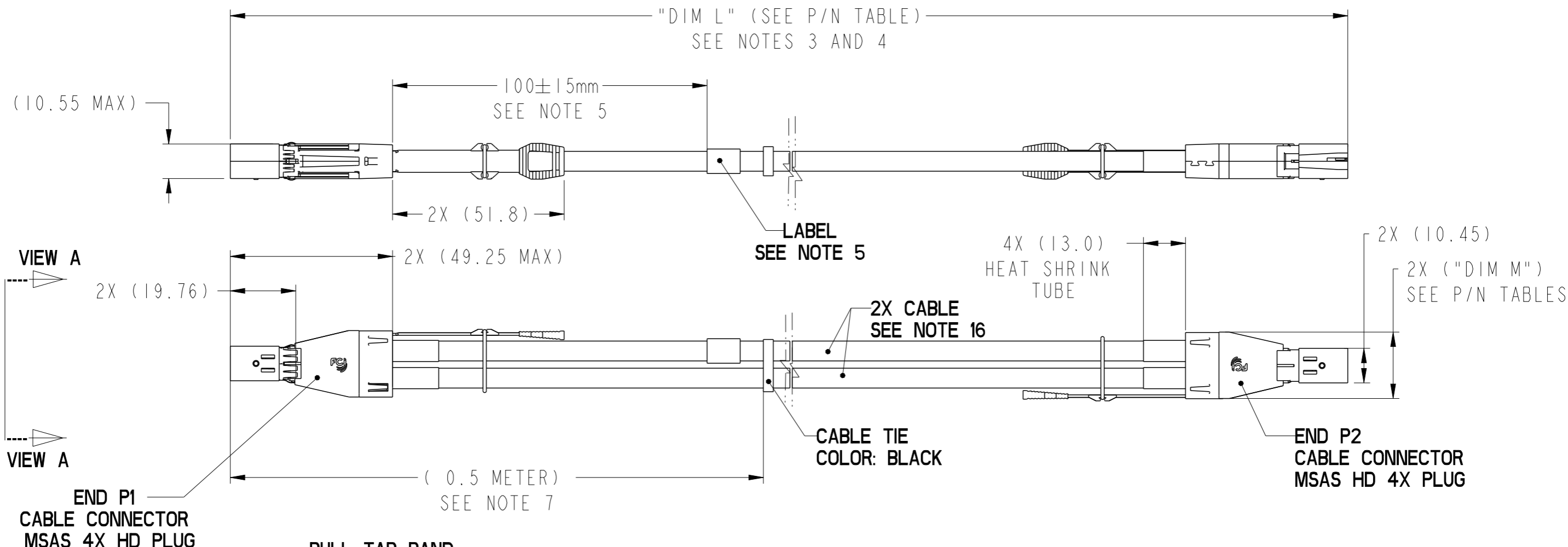

dr	David Lord	2011/09/06	projection	mm	size	A3	scale	1:2
eng	Tommy Lin	2013/12/26			ecn no		ELX-N-16559-1	
chr	-	-			rel level		Released	
appr	Roger Cheng	2013/12/26	product family		C&A		rel level	
			title FINAL ASSEMBLY (PASSIVE) MSAS HD 4X ASSEMBLY (12 Gb/s)		dwg no 10117949		rev K	
www.fci.com			cat. no.		-		Product - Customer Drw	
			sheet 1 of 4					

Copyright FCI.

PRODUCT NUMBER	DESCRIPTION	NOTES
10117949-XXXXLF	NON-HF	SEE SHT. 3
10117949-XXXXHLF	HALOGEN FREE (H)	SEE SHT. 3

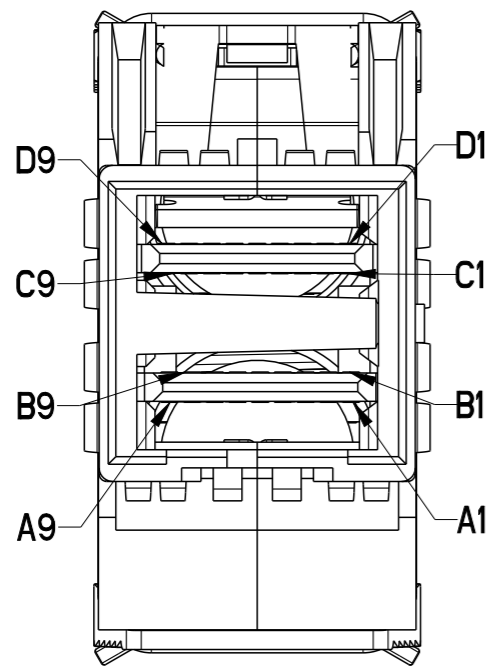

P1
VIEW A
SCALE 4:1

LEGEND:

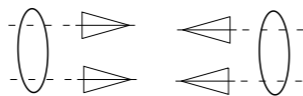

HIGH-SPEED SERIAL
DIFFERENTIAL PAIRS

SIGNAL RETURN

POWER AND MANAGEMENT
INTERFACE

MINIMUM CABLE BEND TABLE					
CABLE	A	B	C	D (nominal)	("DIM Y") NON-HF
24 AWG	29.5	13.0	50.28	∅8.38	92.78
26 AWG			42.6	∅7.1	85.1
28 AWG			36.6	∅6.1	79.1
30 AWG			31.8	∅5.3	74.3

MINIMUM CABLE BEND TABLE					
CABLE	A	B	C	D (nominal)	("DIM Y") HF
24 AWG	29.5	13.0	50.28	∅8.38	92.78
26 AWG			45	∅7.5	87.5
28 AWG			39	∅6.5	81.5
30 AWG			35.4	∅5.9	77.9

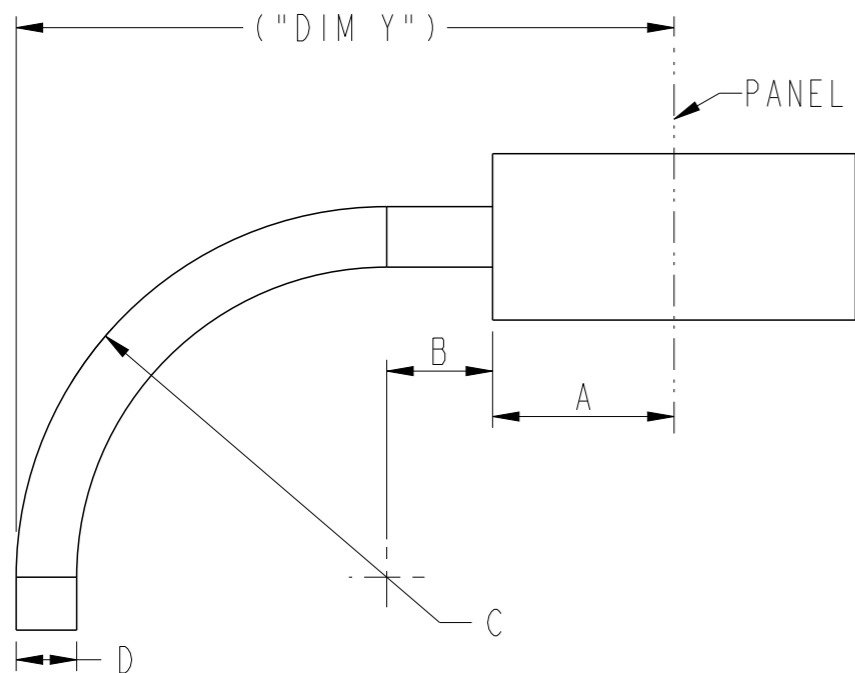

BEND RADIUS
TOP VIEW OF CONNECTOR

WIRING LIST (SEE NOTE 6)					
END P1			END P2		
POSITION	SYMBOL		POSITION	SYMBOL	
D9	GROUND	-----	B9	GROUND	
D8	Tx2-	○-----▷	B8	Rx2-	
D7	Tx2+	○-----▷	B7	Rx2+	
D6	GROUND	-----	B6	GROUND	
D5	Tx0-	○-----▷	B5	Rx0-	
D4	Tx0+	○-----▷	B4	Rx0+	
D3	GROUND	-----	B3	GROUND	
D2	Vman	◁-----▷	B2	ModPrsL	
D1	Vact	◁-----▷	B1	Vact	
C1	SCL	◁-----▷	A1	Reserved	
C2	SDA	◁-----▷	A2	IntL	
C3	GROUND	-----	A3	GROUND	
C4	Tx1+	○-----▷	A4	Rx1+	
C5	Tx1-	○-----▷	A5	Rx1-	
C6	GROUND	-----	A6	GROUND	
C7	Tx3+	○-----▷	A7	Rx3+	
C8	Tx3-	○-----▷	A8	Rx3-	
C9	GROUND	-----	A9	GROUND	
B9	GROUND	-----	D9	GROUND	
B8	Rx2-	◁-----○	D8	Tx2-	
B7	Rx2+	◁-----○	D7	Tx2+	
B6	GROUND	-----	D6	GROUND	
B5	Rx0-	◁-----○	D5	Tx0-	
B4	Rx0+	◁-----○	D4	Tx0+	
B3	GROUND	-----	D3	GROUND	
B2	ModPrsL	◁-----▷	D2	Vman	
B1	Vact	◁-----▷	D1	Vact	
A1	Reserved	◁-----▷	C1	SCL	
A2	IntL	◁-----▷	C2	SDA	
A3	GROUND	-----	C3	GROUND	
A4	Rx1+	◁-----○	C4	Tx1+	
A5	Rx1-	◁-----○	C5	Tx1-	
A6	GROUND	-----	C6	GROUND	
A7	Rx3+	◁-----○	C7	Tx3+	
A8	Rx3-	◁-----○	C8	Tx3-	
A9	GROUND	-----	C9	GROUND	

SHIELD-----▷ SHIELD

dr	David Lord	2011/09/06	projection	mm	size	A3	scale	1:2
eng	Tommy Lin	2013/12/26			ecn no	ELX-N-16559-1	rel level	Released
chr	-	-						
appr	Roger Cheng	2013/12/26	product family	C&A	rev no	10117949	cat. no.	-
			FINAL ASSEMBLY (PASSIVE)					
			MSAS HD 4X ASSEMBLY (12 Gb/s)					
			Product - Customer Drw			sheet 2 of 4		



Copyright FCI.

PART NUMBER (NON-HALOGEN FREE) SEE NOTE 12 AND 16	"DIM L" LENGTH (Meters)	"DIM M" (mm)	AWG
10117949-2003LF	0.3	17.3	30
10117949-2004LF	0.4	17.3	30
10117949-2005LF	0.5	17.3	30
10117949-2006LF	0.6	17.3	30
10117949-2007LF	0.7	17.3	30
10117949-2008LF	0.75	17.3	30
10117949-2009LF	0.9	17.3	30
10117949-2010LF	1.0	17.3	30
10117949-2015LF	1.5	17.3	30
10117949-2020LF	2.0	17.3	30
10117949-3005LF	0.5	17.3	28
10117949-3006LF	0.6	17.3	28
10117949-3007LF	0.7	17.3	28
10117949-3008LF	0.8	17.3	28
10117949-3009LF	0.9	17.3	28
10117949-3010LF	1.0	17.3	28
10117949-3015LF	1.5	17.3	28
10117949-3020LF	2.0	17.3	28
10117949-3025LF	2.5	17.3	28
10117949-3030LF	3.0	17.3	28
10117949-4010LF	1.0	20.1	26
10117949-4015LF	1.5	20.1	26
10117949-4020LF	2.0	20.1	26
10117949-4025LF	2.5	20.1	26
10117949-4030LF	3.0	20.1	26
10117949-4035LF	3.5	20.1	26
10117949-4040LF	4.0	20.1	26
10117949-4045LF	4.5	20.1	26
10117949-4050LF	5.0	20.1	26
10117949-4055LF	5.5	20.1	26
10117949-4060LF	6.0	20.1	26
10117949-5010LF	1.0	20.1	24
10117949-5015LF	1.5	20.1	24
10117949-5020LF	2.0	20.1	24
10117949-5025LF	2.5	20.1	24
10117949-5030LF	3.0	20.1	24
10117949-5035LF	3.5	20.1	24
10117949-5040LF	4.0	20.1	24
10117949-5045LF	4.5	20.1	24
10117949-5050LF	5.0	20.1	24
10117949-5055LF	5.5	20.1	24
10117949-5060LF	6.0	20.1	24
10117949-5065LF	6.5	20.1	24
10117949-5070LF	7.0	20.1	24
10117949-5075LF	7.5	20.1	24
10117949-5080LF	8.0	20.1	24

PART NUMBER (HALOGEN FREE) SEE NOTE 11 AND 16	"DIM L" LENGTH (Meters)	"DIM M" (mm)	AWG
10117949-2003HLF	0.3	17.3	30
10117949-2004HLF	0.4	17.3	30
10117949-2005HLF	0.5	17.3	30
10117949-2006HLF	0.6	17.3	30
10117949-2007HLF	0.7	17.3	30
10117949-2008HLF	0.75	17.3	30
10117949-2009HLF	0.9	17.3	30
10117949-2010HLF	1.0	17.3	30
10117949-2015HLF	1.5	17.3	30
10117949-2020HLF	2.0	17.3	30
10117949-3005HLF	0.5	17.3	28
10117949-3006HLF	0.6	17.3	28
10117949-3007HLF	0.7	17.3	28
10117949-3008HLF	0.8	17.3	28
10117949-3009HLF	0.9	17.3	28
10117949-3010HLF	1.0	17.3	28
10117949-3015HLF	1.5	17.3	28
10117949-3020HLF	2.0	17.3	28
10117949-3025HLF	2.5	17.3	28
10117949-3030HLF	3.0	17.3	28
10117949-4010HLF	1.0	20.1	26
10117949-4015HLF	1.5	20.1	26
10117949-4020HLF	2.0	20.1	26
10117949-4025HLF	2.5	20.1	26
10117949-4030HLF	3.0	20.1	26
10117949-4035HLF	3.5	20.1	26
10117949-4040HLF	4.0	20.1	26
10117949-4045HLF	4.5	20.1	26
10117949-4050HLF	5.0	20.1	26
10117949-4055HLF	5.5	20.1	26
10117949-4060HLF	6.0	20.1	26
10117949-5010HLF	1.0	20.1	24
10117949-5015HLF	1.5	20.1	24
10117949-5020HLF	2.0	20.1	24
10117949-5025HLF	2.5	20.1	24
10117949-5030HLF	3.0	20.1	24
10117949-5035HLF	3.5	20.1	24
10117949-5040HLF	4.0	20.1	24
10117949-5045HLF	4.5	20.1	24
10117949-5050HLF	5.0	20.1	24
10117949-5055HLF	5.5	20.1	24
10117949-5060HLF	6.0	20.1	24
10117949-5065HLF	6.5	20.1	24
10117949-5070HLF	7.0	20.1	24
10117949-5075HLF	7.5	20.1	24
10117949-5080HLF	8.0	20.1	24

dr	David Lord	2011/09/06	projection	mm	size	A3	scale	1:2
eng	Tommy Lin	2013/12/26				ecn no	ELX-N-16559-1	
chr	-	-	product family	C&A		rel level	Released	
appr	Roger Cheng	2013/12/26					FINAL ASSEMBLY (PASSIVE) MSAS HD 4X ASSEMBLY (12 Gb/s)	dwg no 10117949
www.fci.com		cat. no.	-		Product - Customer Drw		sheet 3 of 4	

Copyright FCI.

PRODUCT NUMBER	DESCRIPTION	NOTES
10117949-XXXXLF	NON-HF	SEE SHT. 3
10117949-XXXXHLF	HALOGEN FREE (H)	SEE SHT. 3

NOTES:

- MATERIAL:
BACK SHELLS: ZINC ALLOY/ COPPER UNDERPLATE/ NICKEL OVERPLATE
PULL TAB: THERMOPLASTIC POLYMER
LATCH : STAINLESS STEEL
FERRULE: BRASS
EMI SKIRT: STAINLESS STEEL
LOCTITE
PADDLE CARD: PRINTED CIRCUIT SUBSTRATE
HEAT SHRINK TUBE: POLYOLEFIN
- THIS PRODUCT MEETS THE RESTRICTION OF HAZARDOUS SUBSTANCES IN ELECTRICAL AND ELECTRONIC EQUIPMENT (RoHS) DIRECTIVE (2011/65/EU)
- THIS DIMENSION IS A FINISHED PRODUCT LENGTH.
- UNLESS OTHERWISE SPECIFIED ASSEMBLED LENGTH TOLERANCE IS TO BE:
"DIM L" < 1 METER = ±25mm
"DIM L" 1 METER TO 4 METERS = ± 2% OF "DIM L"
"DIM L" > 4 METERS = +0.00/-4% OF "DIM L"

5. LABEL DETAILS:

	MANUFACTURER CODE OR NAME	COUNTRY ORIGIN	CE MARK
	FCI P/N		
	FCI CUSTOMER DRAWING REVISION		
	FCI SERIAL NUMBER		

FONT SHALL BE CLEARLY VISIBLE AND BLACK IN COLOR.
CE MARK VERTICAL DIMENSION MAY NOT BE LESS THAN 5mm.
SERIAL NUMBER IS ONLY USED FOR TRACKING PRODUCT,DETAIL IS AS BELOW :

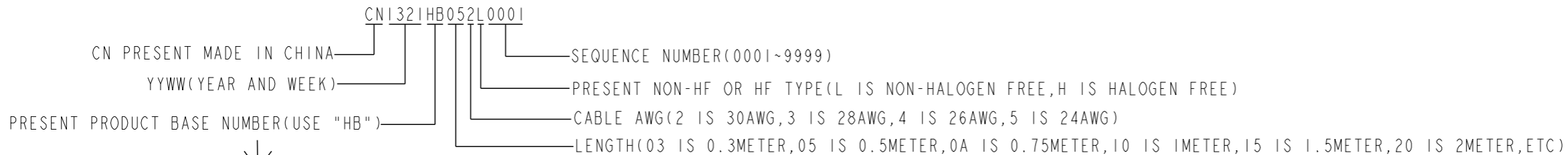



CABLE LABEL EXAMPLE:

	FCI CHINA	CE	← CE MARK VERTICAL DIMENSION MAY NOT BE LESS THAN 5mm,
	10117949-2005LF		
	REV.K		
	CNI321HB052L0001		

- ALL CABLE ASSEMBLIES 100% TESTED FOR CONTINUITY AS DEFINED IN WIRING LIST.
- PLACE A CABLE TIE EVERY 0.5 METER ON ALL ASSEMBLIES, UNLESS OTHERWISE SPECIFIED. IN CASE OF 0.5 METER CABLE ASSEMBLY, CABLE TIE IS TO BE APPLIED AT THE MIDWAY POINT.
- OTHER TESTING PERFORMED AS REQUIRED BY PRODUCT SPECIFICATION: GS-12-651.
- PACKAGING OF LEAD FREE PRODUCTS MEETS LABELING AND PACKAGING PER SPECIFICATION GS-14-920. PACKAGE CABLE ASSEMBLIES PER GS-14-1272. DUST COVERS ARE TO BE ASSEMBLED PRIOR TO PACKAGING. FCI PACKAGE TRACKING BAG LABEL IS ONLY FOR REFERENCE. CE MARK SHOULD BE ADDED ON FCI STANDARD PACKAGE LABEL(GI LABEL), CE MARK VERTICAL DIM. MAY NOT BE LESS THAN 5mm.

NOTES CONTINUED:

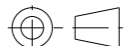
- A "△" SYMBOL WILL BE NEXT TO ANY DIMENSION, VIEW, OR NOTE WHICH HAS BEEN MODIFIED WITH THE CURRENT DRAWING REVISION. THE CURRENT REVISION WILL BE SHOWN IN THE SYMBOL.
- "H" PRODUCT NUMBERS DESIGNATE THE USE OF HALOGEN FREE RAW CABLE.
- HALOGEN FREE RAW CABLE CAN BE USED AS A SUBSTITUTE ON NON-HF PRODUCT NUMBERS.
- CABLE ASSEMBLY CAN MEET SAS 3.0 SPECIFICATION.
- MATES TO SERIES: 10112626 or 10112627 or 10112628
- EEPROM INFORMATION REFER TO FCI LATEST PRODUCT SPEC. GS-12-651.
- CABLE IS OPTIONAL, WHICH HAD BEEN QUALIFIED BY FCI AND MEET FCI PRODUCT SPEC. GS-12-651.

dr	David Lord	2011/09/06			size	A3	scale	1:2
eng	Tommy Lin	2013/12/26			ecn no	ELX-N-16559-1		
chr	-	-			rel level	Released		
appr	Roger Cheng	2013/12/26	product family	C&A		rev	K	
			FINAL ASSEMBLY (PASSIVE)		dwg no	10117949		
			MSAS HD 4X ASSEMBLY (12 Gb/s)		cat. no.	-		Product - Customer Drw



**Стандарт
Электрон
Связь**

Мы молодая и активно развивающаяся компания в области поставок электронных компонентов. Мы поставляем электронные компоненты отечественного и импортного производства напрямую от производителей и с крупнейших складов мира.

Благодаря сотрудничеству с мировыми поставщиками мы осуществляем комплексные и плановые поставки широчайшего спектра электронных компонентов.

Собственная эффективная логистика и склад в обеспечивает надежную поставку продукции в точно указанные сроки по всей России.

Мы осуществляем техническую поддержку нашим клиентам и предпродажную проверку качества продукции. На все поставляемые продукты мы предоставляем гарантию .

Осуществляем поставки продукции под контролем ВП МО РФ на предприятия военно-промышленного комплекса России , а также работаем в рамках 275 ФЗ с открытием отдельных счетов в уполномоченном банке. Система менеджмента качества компании соответствует требованиям ГОСТ ISO 9001.

Минимальные сроки поставки, гибкие цены, неограниченный ассортимент и индивидуальный подход к клиентам являются основой для выстраивания долгосрочного и эффективного сотрудничества с предприятиями радиоэлектронной промышленности, предприятиями ВПК и научно-исследовательскими институтами России.

С нами вы становитесь еще успешнее!

Наши контакты:

Телефон: +7 812 627 14 35

Электронная почта: sales@st-electron.ru

Адрес: 198099, Санкт-Петербург,
Промышленная ул, дом № 19, литера Н,
помещение 100-Н Офис 331