



## NPN Silicon High-Power Transistor

*Qualified per MIL-PRF-19500/102*

Qualified Levels:  
JAN

### DESCRIPTION

This family of high-frequency, epitaxial planar transistors feature low saturation voltage.

**Important:** For the latest information, visit our website <http://www.microsemi.com>.

### FEATURES

- JEDEC registered 2N1016 number
- JAN qualification is available per MIL-PRF-19500/102
- RoHS compliant versions available (commercial grade only)

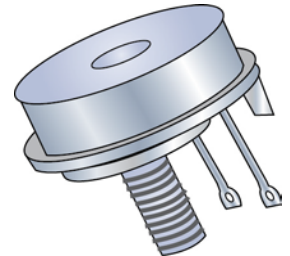

**TO-82 Package**

### APPLICATIONS / BENEFITS

- General purpose transistors for high power applications requiring high frequency switching and low package profile
- Military and other high-reliability applications

### MAXIMUM RATINGS

Parameters / Test Conditions	Symbol	Value	Unit
Operating & Storage Junction Temperature Range	$T_J, T_{stg}$	-65 to +150	°C
Collector-Emitter Voltage	$V_{CEO}$	100 150 200	V
		2N1016B 2N1016C 2N1016D	
Collector-Base Voltage	$V_{CBO}$	100 150 200	V
		2N1016B 2N1016C 2N1016D	
Emitter-Base Voltage	$V_{EBO}$	25	V
Collector Current	$I_C$	7.5	A
Collector Power Dissipation	$P_C$	150	W
		@ $T_C = +45\text{ °C}^{(1)}$	

**Notes:** 1. Derate linearly 1.428 W/°C for  $T_C > +45\text{ °C}$

**MSC – Lawrence**  
6 Lake Street,  
Lawrence, MA 01841  
Tel: 1-800-446-1158 or  
(978) 620-2600  
Fax: (978) 689-0803

**MSC – Ireland**  
Gort Road Business Park,  
Ennis, Co. Clare, Ireland  
Tel: +353 (0) 65 6840044  
Fax: +353 (0) 65 6822298

**Website:**  
[www.microsemi.com](http://www.microsemi.com)

**MECHANICAL and PACKAGING**

- CASE: Hermetically sealed, kovar base, nickel cap
- TERMINALS: Alloy 52 with nickel plating and hot solder dip (Sn63/Pb37) or matte-tin plating for RoHS compliance (available on commercial grade only).
- MARKING: Part number, date code, manufacturer's ID
- WEIGHT: Approximately 24.28 grams
- POLARITY: See [Package Dimensions](#) on last page.

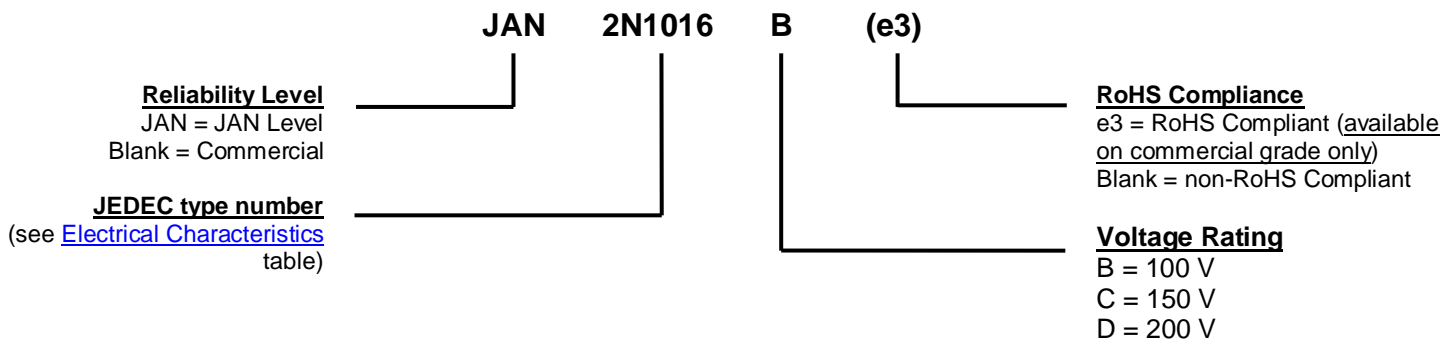
**PART NOMENCLATURE**

**SYMBOLS & DEFINITIONS**

Symbol	Definition
$h_{FE}$	Common-emitter static forward current transfer ratio: The ratio of the dc output current to the dc input current with the output voltage held constant.
$I_B$	Base current: The value of the dc current into the base terminal.
$I_C$	Collector current: The value of the dc current into the collector terminal.
$I_{CBO}$	Collector cutoff current, emitter open: The current into the collector terminal when it is biased in the reverse direction with respect to the base terminal and the emitter terminal is open-circuited.
$I_{CEX}$	Collector cutoff current, circuit between base and emitter: The current into the collector terminal when it is biased in the reverse direction with respect to the emitter terminal, and the base terminal is returned to the emitter terminal through a specified circuit. The collector terminal is considered to be biased in the reverse direction when it is made positive for npn transistors, or negative for pnp transistors, with respect to the emitter terminal.
$I_{EBO}$	Emitter cutoff current, collector open: The current into the emitter terminal when it is biased in the reverse direction with respect to the base terminal and the collector terminal is open-circuited.
$V_{(BR)CEO}$	Collector-emitter breakdown voltage, base open. The breakdown voltage between the collector and emitter terminals when the collector terminal is biased in the reverse direction with respect to the emitter terminal, and the base terminal is open circuited. The collector terminal is considered to be biased in the reverse direction when it is made positive for npn transistors, or negative for pnp transistors, with respect to the emitter terminal.
$V_{BE(sat)}$	Base-emitter saturation voltage: The voltage between the base and emitter terminals for specified base current and collector current conditions that are intended to ensure that the collector junction is forward biased.
$V_{CB}$	Collector-base voltage: The dc voltage between the collector and the base.
$V_{CBO}$	Collector-base voltage, emitter open: The voltage between the collector and base terminals when the emitter terminal is open-circuited.
$V_{CE}$	Collector-emitter voltage: The dc voltage between the collector and the emitter.
$V_{CE(sat)}$	Collector-emitter saturation voltage: The voltage between the collector and emitter terminals under conditions of base current or base-emitter voltage beyond which the collector current remains essentially constant as the base current or voltage is increased.
$V_{CEO}$	Collector-emitter voltage, base open: The voltage between the collector and the emitter terminals when the base terminal is open-circuited.
$V_{EB}$	Emitter-base voltage: The dc voltage between the emitter and the base
$V_{EBO}$	Emitter-base voltage, collector open: The voltage between the emitter and base terminals with the collector terminal open-circuited.

**ELECTRICAL CHARACTERISTICS**
**OFF CHARACTERISTICS**

Parameters / Test Conditions		Symbol	Min.	Max.	Unit
Collector-Emitter Breakdown Voltage $I_C = 200 \text{ mA}$	2N1016B 2N1016C 2N1016D	$V_{(BR)CEO}$	100 150 200		V
Collector-Emitter Cutoff Current $V_{EB} = 1.5 \text{ V}, V_{CE} = 100 \text{ V}$ $V_{EB} = 1.5 \text{ V}, V_{CE} = 150 \text{ V}$ $V_{EB} = 1.5 \text{ V}, V_{CE} = 200 \text{ V}$	2N1016B 2N1016C 2N1016D	$I_{CEX}$		1.0	mA
Collector-Base Cutoff Current $V_{CB} = 100 \text{ V}$ $V_{CB} = 150 \text{ V}$ $V_{CB} = 200 \text{ V}$	2N1016B 2N1016C 2N1016D	$I_{CBO}$		1.0	mA
Emitter-Base Cutoff Current $V_{EB} = 25.0 \text{ V}$		$I_{EBO}$		1.0	mA

**ON CHARACTERISTICS <sup>(1)</sup>**

Parameters / Test Conditions		Symbol	Min.	Max.	Unit
Forward-Current Transfer Ratio $I_C = 2 \text{ A}, V_{CE} = 4.0 \text{ V}$ $I_C = 5 \text{ A}, V_{CE} = 4.0 \text{ V}$ $I_C = 7.5 \text{ A}, V_{CE} = 4.0 \text{ V}$	2N1016B 2N1016C 2N1016D	$h_{FE}$	20 10 6	80 35 20	
Collector-Emitter Saturation Voltage $I_C = 5 \text{ A}, I_B = 1 \text{ A}$		$V_{CE(sat)}$		2.5	V
Base-Emitter Saturation Voltage $I_C = 5 \text{ A}, I_B = 1 \text{ A}$		$V_{BE(sat)}$		4.0	V

**SWITCHING CHARACTERISTICS**

Parameters / Test Conditions (for all symbols)		Symbol	Min.	Max.	Unit
Pulse Response	$I_C = 5 \text{ A}, V_{EB} = 6 \text{ V}, V_{CE} = 12 \text{ V}$ $I_{B1} \text{ and } I_{B2} = 1.5 \text{ A}$	$t_d + t_r$		10	$\mu\text{s}$
	$I_C = 5 \text{ A}, V_{EB} = 6 \text{ V}, V_{CE} = 12 \text{ V}$ $I_{B1} \text{ and } I_{B2} = 1.5 \text{ A}$	$t_s + t_f$		15	$\mu\text{s}$

**NOTES:** (1) Pulse Test: pulse width = 300  $\mu\text{s}$ , duty cycle  $\leq 2.0\%$

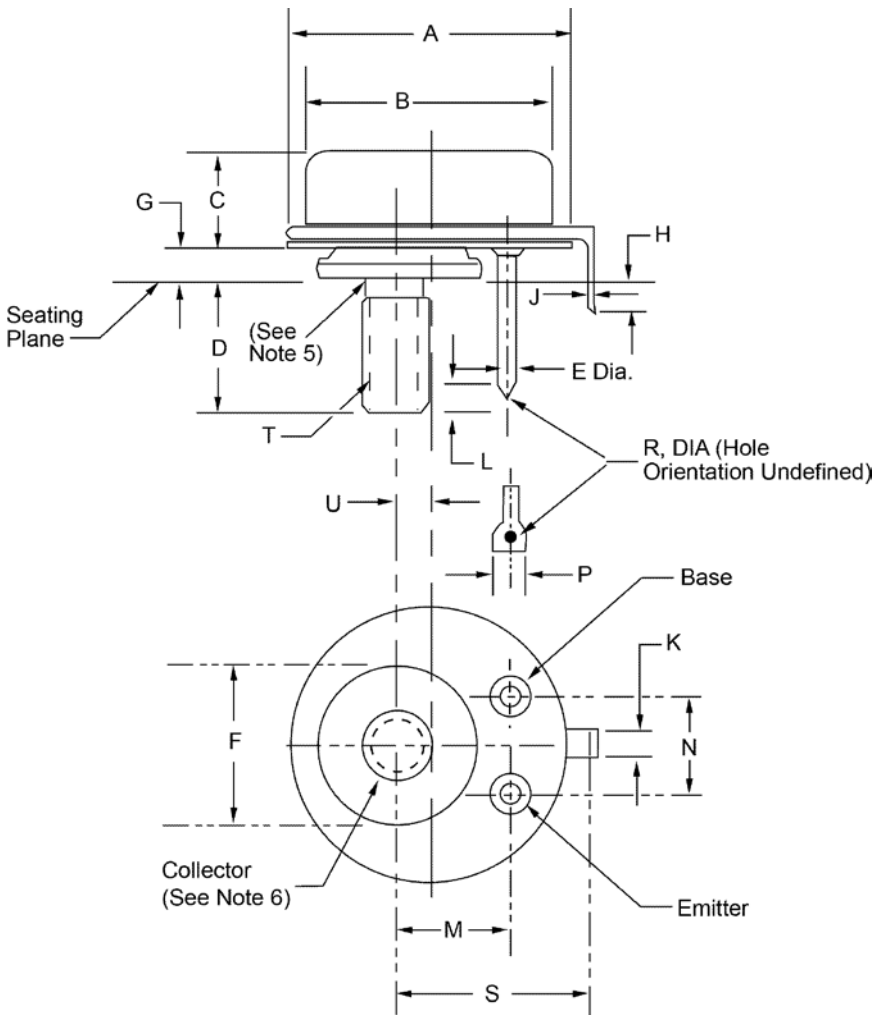
**PACKAGE DIMENSIONS**

Symbol	Dimensions				Note
	Inch		Millimeters		
	Min	Max	Min	Max	
A	1.24	1.28	31.5	32.51	
B	-	1.130	-	28.70	
C	0.50	0.56	12.70	14.22	
D	0.55	0.58	13.97	14.73	
E	0.045	0.055	1.14	1.40	4
F	0.73	0.80	18.54	20.32	
G	0.07	0.14	1.78	3.56	
H	0.13	0.19	3.30	4.83	
J	0.014	0.024	0.36	0.61	
K	0.14	0.17	3.56	4.32	
L	0.10	0.14	2.54	3.56	
M	0.48	0.52	12.19	13.21	
N	0.35	0.40	8.89	10.16	
P	0.09	0.11	2.29	2.79	4
R	0.050	0.060	1.27	1.52	
S	0.81	0.85	20.57	21.59	
T	-	-	-	-	3
U	0.14	0.17	3.56	4.32	

1. Dimensions are in inches.
2. Millimeters are given for information only.
3. See NBS Handbook H28. 5/16 -24 UNF-2A
4. Two leads
5. Reference point for temperature measurement

# Mouser Electronics

Authorized Distributor

Click to View Pricing, Inventory, Delivery & Lifecycle Information:

[Microsemi:](#)

[2N1016C](#) [2N1016B](#) [2N1016D](#)



**Стандарт  
Электрон  
Связь**

Мы молодая и активно развивающаяся компания в области поставок электронных компонентов. Мы поставляем электронные компоненты отечественного и импортного производства напрямую от производителей и с крупнейших складов мира.

Благодаря сотрудничеству с мировыми поставщиками мы осуществляем комплексные и плановые поставки широчайшего спектра электронных компонентов.

Собственная эффективная логистика и склад в обеспечивает надежную поставку продукции в точно указанные сроки по всей России.

Мы осуществляем техническую поддержку нашим клиентам и предпродажную проверку качества продукции. На все поставляемые продукты мы предоставляем гарантию .

Осуществляем поставки продукции под контролем ВП МО РФ на предприятия военно-промышленного комплекса России , а также работаем в рамках 275 ФЗ с открытием отдельных счетов в уполномоченном банке. Система менеджмента качества компании соответствует требованиям ГОСТ ISO 9001.

Минимальные сроки поставки, гибкие цены, неограниченный ассортимент и индивидуальный подход к клиентам являются основой для выстраивания долгосрочного и эффективного сотрудничества с предприятиями радиоэлектронной промышленности, предприятиями ВПК и научно-исследовательскими институтами России.

С нами вы становитесь еще успешнее!

**Наши контакты:**

**Телефон:** +7 812 627 14 35

**Электронная почта:** [sales@st-electron.ru](mailto:sales@st-electron.ru)

**Адрес:** 198099, Санкт-Петербург,  
Промышленная ул, дом № 19, литера Н,  
помещение 100-Н Офис 331