

NPN SILICON HIGH-FREQUENCY TRANSISTOR

Qualified per MIL-PRF-19500/398

DEVICES

2N3866 2N3866UB
2N3866A 2N3866AUB

LEVELS
JAN
JANTX
JANTXV
JANS

ABSOLUTE MAXIMUM RATINGS ($T_C = +25^\circ\text{C}$ unless otherwise noted)

Parameters / Test Conditions	Symbol	Value	Unit
Collector-Emitter Voltage	V_{CEO}	30	Vdc
Collector-Base Voltage	V_{CBO}	60	Vdc
Emitter-Base Voltage	V_{EBO}	305	Vdc
Collector Current	I_C	400	mAdc
Total Power Dissipation @ $T_A = +25^\circ\text{C}$	P_T	1.0 0.5	W
Operating & Storage Junction Temperature Range	T_j, T_{stg}	-65 to +200	$^\circ\text{C}$
Thermal Resistance, Junction-to-Case	$R_{\theta JC}$	60.0	$^\circ\text{C/W}$

NOTE:

- Derate linearly 5.71mW/ $^\circ\text{C}$ (2N3866, 2N3866A) and 3.08mW/ $^\circ\text{C}$ (2N3866UB / 2N3866AUB) above $T_A > +25^\circ\text{C}$
- T_A = room ambient as defined in the general requirements of MIL-PRF-19500
- $P_T = 2.9\text{W}$ at $T_C = +25^\circ\text{C}$, derate at 16.6mW/ $^\circ\text{C}$ above $T_C > +25^\circ\text{C}$

ELECTRICAL CHARACTERISTICS ($T_A = +25^\circ\text{C}$, unless otherwise noted)

Parameters / Test Conditions	Symbol	Min.	Max.	Unit
OFF CHARACTERISTICS				
Collector-Emitter Breakdown Voltage $I_C = 5.0\text{mA}$	$V_{(BR)CEO}$	30		Vdc
Collector-Base Breakdown Voltage $I_C = 100\mu\text{A}$	$V_{(BR)CBO}$	60		Vdc
Emitter-Base Breakdown Voltage $I_E = 100\mu\text{A}$	$V_{(BR)EBO}$	3.5		Vdc
Collector-Emitter Cutoff Current $V_{CE} = 28\text{Vdc}$	I_{CEO}		20	μAdc
Collector-Emitter Cutoff Current $V_{CE} = 55\text{Vdc}$	I_{CES1}		100	μAdc

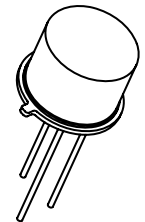

TO-39 (TO-205AD)
2N3866, 2N3866A

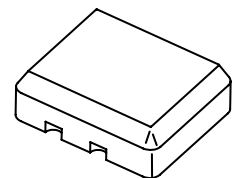

UB Package
2N3866UB, 2N3866AUB

ELECTRICAL CHARACTERISTICS ($T_A = +25^\circ\text{C}$, unless otherwise noted)

Parameters / Test Conditions	Symbol	Min.	Max.	Unit
ON CHARACTERISTICS ⁽³⁾				
Forward-Current Transfer Ratio $I_C = 100\mu\text{Adc}$, $V_{CE} = 5.0\text{Vdc}$ 2N3866, 2N3866UB	h_{FE}	15	200	
2N3866A, 2N3866AUB		25	200	
$I_C = 360\text{mAdc}$, $V_{CE} = 5.0\text{Vdc}$ 2N3866, 2N3866UB		5		
2N3866A, 2N3866AUB		8		
Collector-Emitter Saturation Voltage $I_C = 100\text{mAdc}$, $I_B = 10\text{mAdc}$	$V_{CE(sat)}$		1.0	Vdc
Collector-Emitter Cutoff Current – High Temperature Operation $V_{CE} = 55\text{Vdc}$ $T_A = +150^\circ\text{C}$	I_{CES2}		2.0	mAdc
Forward Current Transfer Ratio – Low Temperature Operation $V_{CE} = 5.0\text{Vdc}$ $I_C = 50\text{mAdc}$, $T_A = -55^\circ\text{C}$ 2N3866, 2N3866UB	H_{FE3}	7		
2N3866A, 2N3866AUB		12		

DYNAMIC CHARACTERISTICS

Parameters / Test Conditions	Symbol	Min.	Max.	Unit
Magnitude of Common Emitter Small-Signal Short-Circuit Forward Current Transfer Ratio $I_C = 50\text{mAdc}$, $V_{CE} = 15\text{Vdc}$, $f = 100\text{MHz}$ 2N3866, 2N3866UB	$ h_{fe} $	2.5	8.0	
2N3866A, 2N3866AUB		4.0	7.5	
Output Capacitance $V_{CB} = 28\text{Vdc}$, $I_E = 0$, $100\text{kHz} \leq f \leq 1.0\text{MHz}$	C_{obo}		3.5	pF

POWER OUTPUT CHARACTERISTICS

Parameters / Test Conditions	Symbol	Min.	Max.	Unit
Power Output $V_{CC} = 28\text{Vdc}$; $P_{in} = 0.15\text{W}$; $f = 400\text{MHz}$ * $V_{CC} = 28\text{Vdc}$; $P_{in} = 0.075\text{W}$; $f = 400\text{MHz}$ *	P_{1out} P_{2out}	1.0 0.5	2.0	W
Collector Efficiency $V_{CC} = 28\text{Vdc}$; $P_{in} = 0.15\text{W}$; $f = 400\text{MHz}$ $V_{CC} = 28\text{Vdc}$; $P_{in} = 0.075\text{W}$; $f = 400\text{MHz}$ * See Figure 4 on /398	n1 n2	45 40		%
Clamp Inductive Collector-Emitter Breakdown Voltage $V_{BE} = 1.5\text{Vdc}$ $I_C = 40\text{mAdc}$	$V_{(BR)CEX}$	55		Vdc

(4) Pulse Test: Pulse Width = 300 μs , Duty Cycle $\leq 2.0\%$.

PACKAGE DIMENSIONS

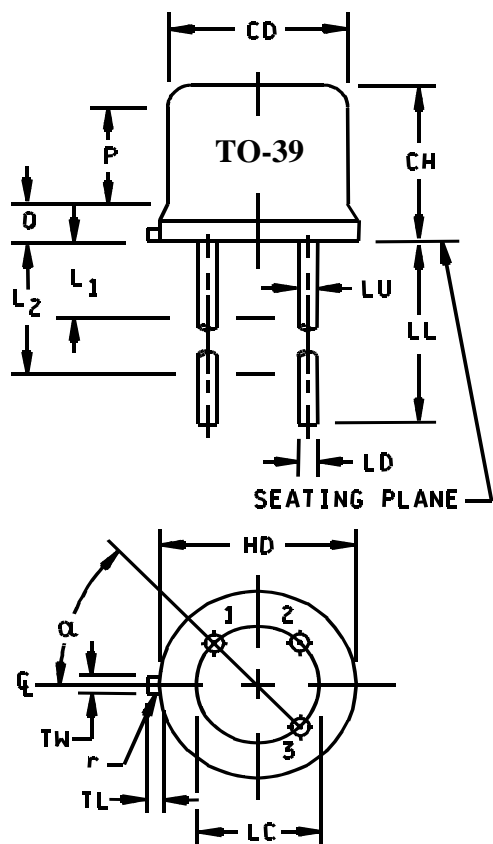

Symbol	Dimensions				Notes
	Inches		Millimeters		
	Min	Max	Min	Max	
CD	.305	.335	7.75	8.51	6
CH	.240	.260	6.10	6.60	
HD	.335	.370	8.51	9.40	
LC	.200 TP		5.08 TP		7
LD	.016	.021	0.41	0.53	8, 9
LL	.500	.750	12.70	19.05	8, 9
LU	.016	.019	0.41	0.48	8, 9
L ₁		.050		1.27	8, 9
L ₂	.250		6.35		8, 9
P	.100		2.54		7
Q		.030		0.76	5
TL	.029	.045	0.74	1.14	3, 4
TW	.028	.034	0.71	0.86	3
r		.010		0.25	10
α	45° TP				7

NOTES:

- Dimensions are in inches.
- Millimeters are given for general information only.
- Beyond r (radius) maximum, TW shall be held for a minimum length of .011 (0.28 mm).
- Dimension TL measured from maximum HD.
- Body contour optional within zone defined by HD, CD, and Q.
- CD shall not vary more than .010 inch (0.25 mm) in zone P. This zone is controlled for automatic handling.
- Leads at gauge plane .054 +.001 -.000 inch (1.37 +0.03 -0.00 mm) below seating plane shall be within .007 inch (0.18 mm) radius of true position (TP) at maximum material condition (MMC) relative to tab at MMC. The device may be measured by direct methods or by gauging procedure.
- Dimension LU applies between L₁ and L₂. Dimension LD applies between L₂ and LL minimum. Diameter is uncontrolled in and beyond LL minimum.
- All three leads.
- The collector shall be internally connected to the case.
- Dimension r (radius) applies to both inside corners of tab.
- In accordance with ASME Y14.5M, diameters are equivalent to Φx symbology.
- Lead 1 = emitter, lead 2 = base, lead 3 = collector.

FIGURE 1. Physical dimensions (TO-39)

PACKAGE DIMENSIONS

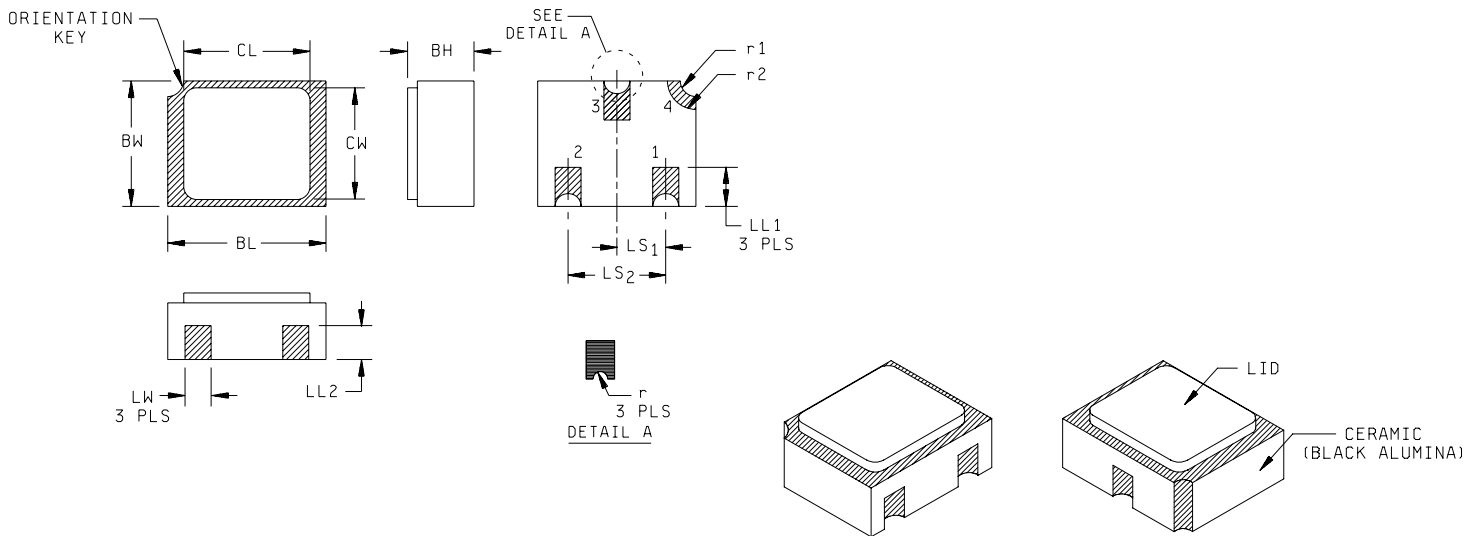

Letter	Dimensions				Note
	Inches		Millimeters		
	Min	Max	Min	Max	
BH	.046	.056	1.17	1.42	
BL	.115	.128	2.92	3.25	
BW	.085	.108	2.16	2.74	
CL		.128		3.25	
CW		.108		2.74	
LL ₁	.022	.038	0.56	0.96	
LL ₂	.017	.035	0.43	0.89	
LS ₁	.036	.040	0.91	1.02	
LS ₂	.071	.079	1.81	2.01	
LW	.016	.024	0.41	0.61	
r		.008		.203	
r ₁		.012		.305	
r ₂		.022		.559	

NOTES:

1. Dimensions are in inches.
2. Millimeters are given for general information only.
3. Hatched areas on package denote metallized areas.
4. Lid material: Kovar.
5. Pad 1 = Base, Pad 2 = Emitter, Pad 3 = Collector, Pad 4 = Shielding connected to the lid.
6. In accordance with ASME Y14.5M, diameters are equivalent to Φ x symbology.

FIGURE 3. Physical dimensions, surface mount (UB).



Стандарт Электрон Связь

Мы молодая и активно развивающаяся компания в области поставок электронных компонентов. Мы поставляем электронные компоненты отечественного и импортного производства напрямую от производителей и с крупнейших складов мира.

Благодаря сотрудничеству с мировыми поставщиками мы осуществляем комплексные и плановые поставки широчайшего спектра электронных компонентов.

Собственная эффективная логистика и склад в обеспечивает надежную поставку продукции в точно указанные сроки по всей России.

Мы осуществляем техническую поддержку нашим клиентам и предпродажную проверку качества продукции. На все поставляемые продукты мы предоставляем гарантию .

Осуществляем поставки продукции под контролем ВП МО РФ на предприятия военно-промышленного комплекса России , а также работаем в рамках 275 ФЗ с открытием отдельных счетов в уполномоченном банке. Система менеджмента качества компании соответствует требованиям ГОСТ ISO 9001.

Минимальные сроки поставки, гибкие цены, неограниченный ассортимент и индивидуальный подход к клиентам являются основой для выстраивания долгосрочного и эффективного сотрудничества с предприятиями радиоэлектронной промышленности, предприятиями ВПК и научно-исследовательскими институтами России.

С нами вы становитесь еще успешнее!

Наши контакты:

Телефон: +7 812 627 14 35

Электронная почта: sales@st-electron.ru

Адрес: 198099, Санкт-Петербург,
Промышленная ул, дом № 19, литера Н,
помещение 100-Н Офис 331