

# Low Side $\mu$ Power Current Sense Amplifier

## Introduction

The ISL28133CSENSEV1Z evaluation board is designed specifically for low side current sensing up to 10A of current. The evaluation board uses a 1m $\Omega$  current sense resistor that is capable of handling 4W of power dissipation. The ISL28133 micropower Zero Drift Amplifier gains the current sensing input signal and can be used to directly drive ADC inputs.

The ISL28133CSENSEV1Z evaluation board is optimized to operate at +5V. An ISL21070 micropower 2.5V voltage reference sets a zero current reading of 2.5V at the amplifier output to interface with ADCs operating at 5V. The voltage reference raises the common mode input by approximately 40mV above GND at zero current flow. This connection enables bi-directional current sensing, allowing the sense voltage to be positive or negative relative to the common mode voltage. This is helpful for applications such as the charging/discharging current from an Electric Vehicle battery or motors that switch polarity.

With the input common mode at 40mV above ground and a 1m $\Omega$  sense resistor, this allows  $\pm 40$ A current sensing before amplifier saturation. However, due to PCB copper resistance causing error at high currents, the recommended current sense is  $\pm 10$ A.

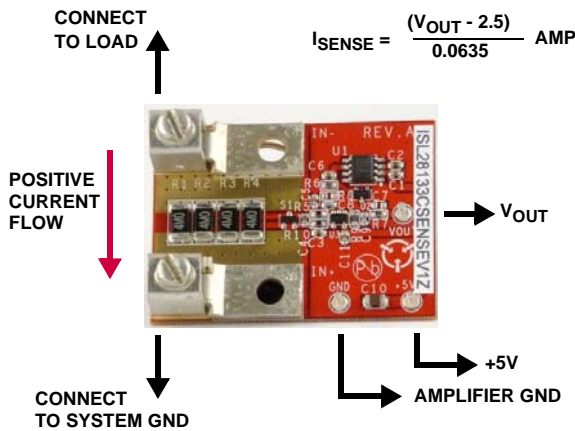

FIGURE 1. ISL28133CSENSEV1Z EVALUATION BOARD

## Board Layout

The evaluation board is laid out with heavy duty screw lug terminals that allow connections of wires up to 6 AWG. The 1m $\Omega$  sense resistance is formed from four 4m $\Omega$  2512 style resistors to increase power dissipation capacity of the sense circuitry. The total power dissipation critically allowed is 4W. The PCB board is made using 2oz copper PCB with the current path routed on the top and bottom layer, minimizing trace resistance to maintain accurate current sense resistance. To further reduce sense errors, the current sensing uses a Kelvin connection with the sense voltage pick up points at the center of the current density distribution.

Amplifier U3 gains up the voltage drop developed across the sense resistor from the current flow. Voltage Reference U2 sets the zero current reading output of the amplifier at 2.5V.

## Quick Setup Guide

1. Connect single supply +5VDC to +5V and GND terminals.
2. Connect low side load to terminal lugs. Current flow from top to bottom of board.
3. At no load,  $V_{OUT}$  is 2.5V.
4. With 1m $\Omega$  sense resistance and amplifier gain of 63.5V/V, the sense current reading is:  $(V_{OUT} - 2.5V)/0.0635$  in Amps.

REF	PART NUMBER	COMMENTS
U1	DNP	Not Populated On Board
U2	ISL21070	Micropower 2.5V Voltage Reference
U3	ISL28133	Micropower Zero Drift Amplifier

CURRENT SENSE SPECIFICATIONS	
Supply Voltage Range	3.0V to 5.0V Optimized for 5V Operation
Max Sense Current	$\pm 10$ A recommended $\pm 40$ A Before Amplifier Saturation
Abs Max Sense Current	60 Amps Thermally Limited by Sense Resistor
Current Sense Resolution	$\pm 10$ mA
Current Sense Accuracy	2%
Voltage to Current Conversion	$I_{SENSE} = (V_{OUT} - 2.5V) / 0.0635$ Amps
Amplifier Bandwidth	6kHz

## Measuring Very High Current

The reference design is capable of sensing currents greater than  $\pm 40$ A, however, it is limited mechanically from the temperature rise of the copper PCB layout and current sense resistor and limited electrically by amplifier saturation. One must consider the temperature rise of the PCB trace from the power dissipated under high currents, which may cause the copper trace to delaminate. The high current carrying PCB trace is made with 2oz copper on FR4 board both top and bottom layers. The trace dimension is approximately 25mm width and 40mm length. Substantial vias are used to connect the planes for lower thermal impedance. The current sense resistance is capable of 4W dissipation max.

# Application Note 1778

## Bill of Materials

PART NUMBER	REFERENCE DESIGNATOR	DESCRIPTION	MANUFACTURER	MANUFACTURER PART
DNP	U1	DO NOT POPULATE OR PURCHASE		
ISL21070CIH325Z	U2	Low Power 2.5V Voltage Reference, SOT23	INTERSIL	ISL21070CIH325Z
ISL28133FHZ	U3	Low Power Zero Drift Amplifier, SOT23	INTERSIL	ISL28133FHZ
H1045-00101-50V5-T	C8, C9	CAP, SMD, 0603, 100pF, 50V, 5%, COG, ROHS	GENERIC	
H1045-00102-50V5-T	C4	CAP, SMD, 0603, 1000pF, 50V, 5%, COG, ROHS	GENERIC	
H1045-00103-50V10-T	C1, C3, C5, C6, C11	CAP, SMD, 0603, 0.01μF, 50V, 10%, X7R, ROHS	GENERIC	
H1045-00104-50V10-T	C2	CAP, SMD, 0603, 0.1μF, 50V, 10%, X7R, ROHS	GENERIC	
H1045-DNP	C7	CAP, SMD, 0603, DNP-PLACE HOLDER, ROHS		
H1065-00475-50V10-T	C10	CAP, SMD, 1206, 4.7μF, 50V, 10%, X5R, ROHS	GENERIC	
BAV99LT1G-T	S1	DIODE-SWITCHING, SMD, SOT23, 70V, 0.2A, ROHS	ON SEMICONDUCTOR	BAV99LT1G
H2511-00R00-1/10W-T	R7	RES, SMD, 0603, 0Ω, 1/10W, TF, ROHS	GENERIC	
H2511-01623-1/10W1-T	R6, R9	RES, SMD, 0603, 162k, 1/10W, 1%, TF, ROHS	GENERIC	
H2511-02551-1/10W1-T	R5, R10	RES, SMD, 0603, 2.55k, 1/10W, 1%, TF, ROHS	GENERIC	
H2511-DNP	R8	RES, SMD, 0603, DNP-PLACE HOLDER, ROHS		
H2515-0R004-1W1-T	R1-R4	RES, SMD, 2512, 0.004Ω, 1W, 1%, TF, ROHS	GENERIC	

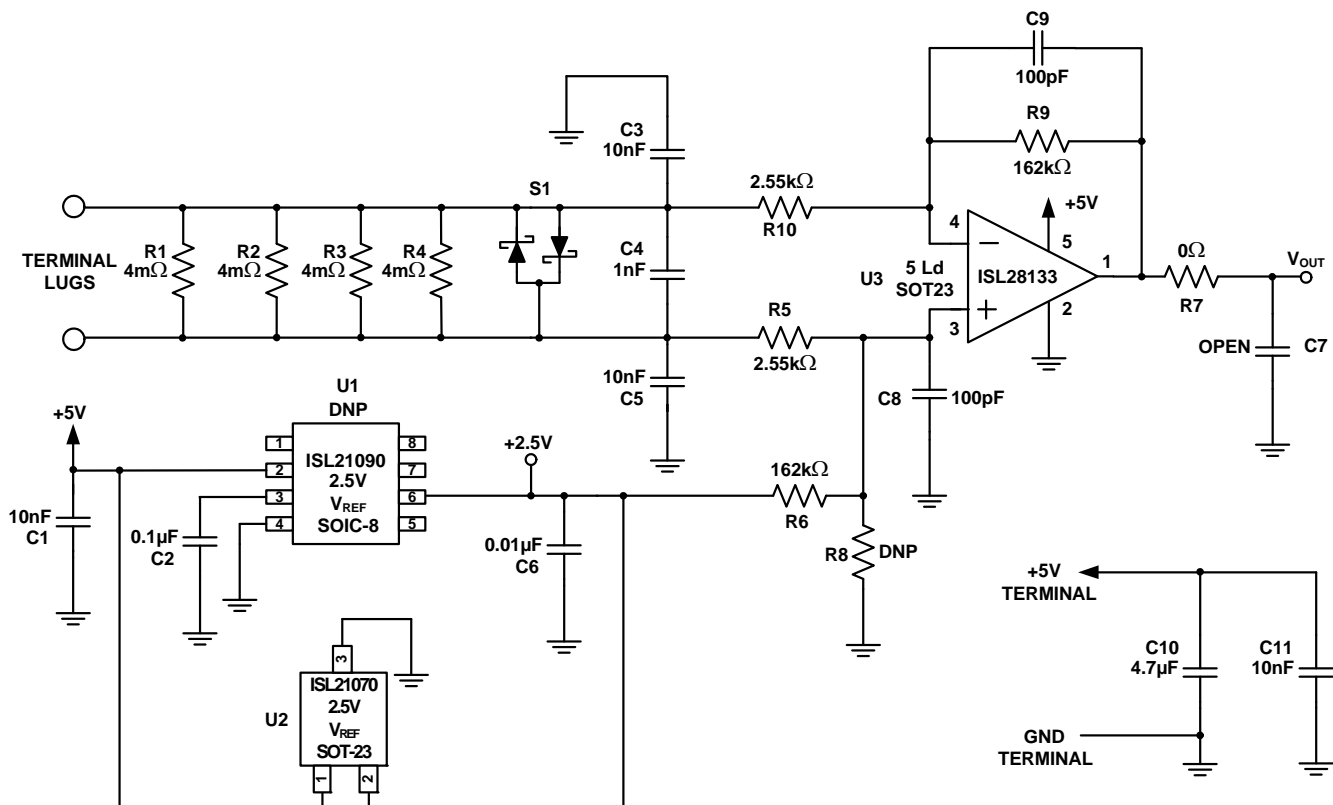

FIGURE 2. CURRENT SENSE AMPLIFIER SCHEMATIC

# Application Note 1778

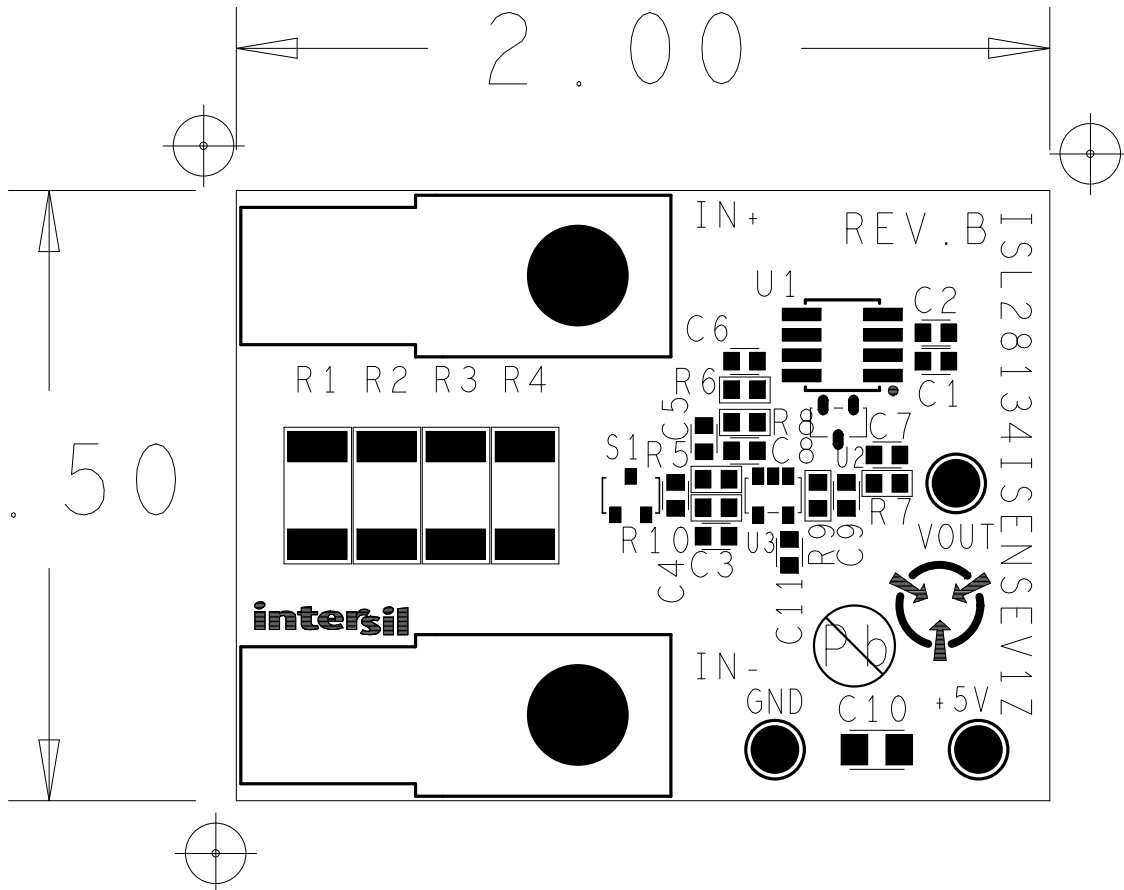

FIGURE 3. CURRENT SENSE AMPLIFIER ASSEMBLY DRAWING

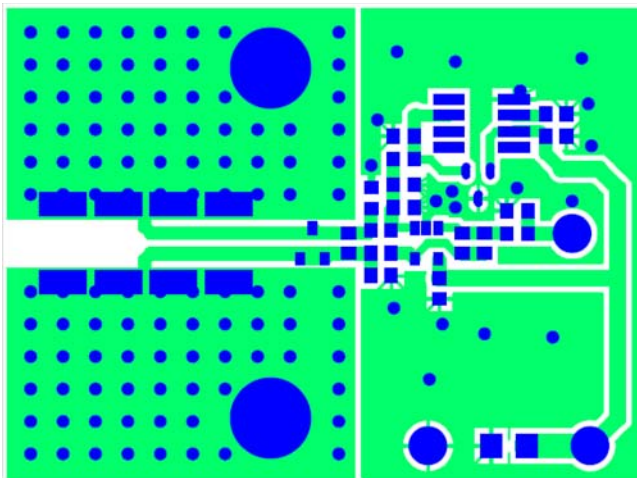

FIGURE 4. PCB TOP LAYER

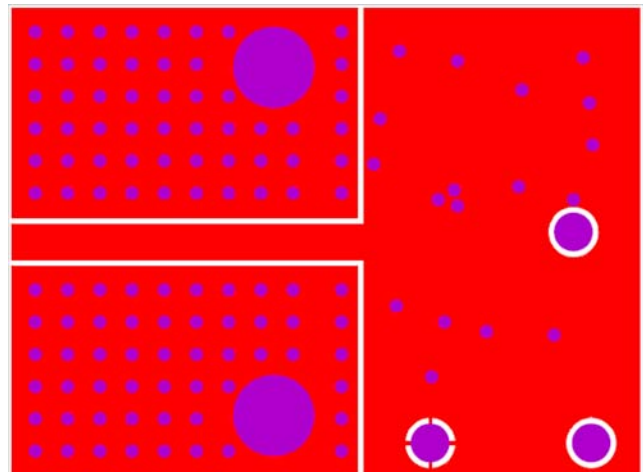

FIGURE 5. PCB BOTTOM LAYER

Intersil Corporation reserves the right to make changes in circuit design, software and/or specifications at any time without notice. Accordingly, the reader is cautioned to verify that the Application Note or Technical Brief is current before proceeding.

For information regarding Intersil Corporation and its products, see [www.intersil.com](http://www.intersil.com)



## Стандарт Электрон Связь

Мы молодая и активно развивающаяся компания в области поставок электронных компонентов. Мы поставляем электронные компоненты отечественного и импортного производства напрямую от производителей и с крупнейших складов мира.

Благодаря сотрудничеству с мировыми поставщиками мы осуществляем комплексные и плановые поставки широчайшего спектра электронных компонентов.

Собственная эффективная логистика и склад в обеспечивает надежную поставку продукции в точно указанные сроки по всей России.

Мы осуществляем техническую поддержку нашим клиентам и предпродажную проверку качества продукции. На все поставляемые продукты мы предоставляем гарантию .

Осуществляем поставки продукции под контролем ВП МО РФ на предприятия военно-промышленного комплекса России , а также работаем в рамках 275 ФЗ с открытием отдельных счетов в уполномоченном банке. Система менеджмента качества компании соответствует требованиям ГОСТ ISO 9001.

Минимальные сроки поставки, гибкие цены, неограниченный ассортимент и индивидуальный подход к клиентам являются основой для выстраивания долгосрочного и эффективного сотрудничества с предприятиями радиоэлектронной промышленности, предприятиями ВПК и научно-исследовательскими институтами России.

С нами вы становитесь еще успешнее!

### Наши контакты:

**Телефон:** +7 812 627 14 35

**Электронная почта:** [sales@st-electron.ru](mailto:sales@st-electron.ru)

**Адрес:** 198099, Санкт-Петербург,  
Промышленная ул, дом № 19, литера Н,  
помещение 100-Н Офис 331