

# **TSB12LV32-EP**

**IEEE 1394-1995 and P1394a Compliant  
General-Purpose Link-Layer Controller**

## *Data Manual*

# Contents

<i>Section</i>	<i>Page</i>
<b>1 Overview</b> .....	<b>1</b>
1.1 TSB12LV32 Description .....	1
1.2 TSB12LV32-EP Features .....	1
1.3 Functional Block Diagram .....	2
1.4 Terminal Assignments .....	3
1.5 Terminal Functions .....	4
1.5.1 STAT0, STAT1, and STAT2 Programming .....	6
1.6 Ordering Information .....	6
<b>2 Internal Registers</b> .....	<b>7</b>
2.1 TSB12LV32 Configuration Registers .....	7
2.2 Configuration Register Definitions .....	8
2.2.1 Version Register at 00h .....	8
2.2.2 Data-Mover Control Register at 04h .....	8
2.2.3 Control Register at 08h .....	10
2.2.4 Interrupt/Interrupt Mask Registers at 0Ch and 10h .....	12
2.2.5 Cycle Timer Register at 14h .....	13
2.2.6 Isochronous Port Register at 18h .....	14
2.2.7 Maint_Control Register at 1Ch .....	15
2.2.8 Diagnostic Register at 20h .....	16
2.2.9 Phy Access Register at 24h .....	17
2.2.10 Reserved Registers at 28h–2Ch .....	17
2.2.11 FIFO Status Register at 30h .....	18
2.2.12 Bus Reset Register at 34h .....	19
2.2.13 Header0 Register at 38h .....	19
2.2.14 Header1 Register at 3Ch .....	20
2.2.15 Header2 Register at 40h .....	21
2.2.16 Header3 Register at 44h .....	22
2.2.17 Trailer Register at 48h .....	23
2.2.18 Asynchronous Retry Register at 4Ch .....	24
<b>3 Microcontroller Interface</b> .....	<b>25</b>
3.1 Microcontroller Byte Stack (Write) Operation .....	26
3.2 Microcontroller Byte Unstack (Read) Operation .....	27
3.3 Microcontroller Interface Read/Write Timing .....	27
3.3.1 Microcontroller Handshake Mode .....	27
3.3.2 Microcontroller Fixed-Timing Mode .....	30
3.3.3 Microcontroller ColdFire Mode .....	35
3.3.4 Microcontroller Critical Timing .....	37
3.3.5 Endian Swapping .....	38
<b>4 Link Core</b> .....	<b>41</b>
4.1 Physical Interface .....	41
4.2 Transmitter .....	41
4.3 Receiver .....	41
4.4 Cycle Timer .....	42
4.5 Cycle Monitor .....	42
4.6 Cyclic Redundancy Check (CRC) .....	42
4.7 Received Packet Routing Control Logic .....	42

<b>5</b>	<b>Data-Mover Port Interface</b>	<b>45</b>
5.1	Data-Mover Data Flow Diagram	47
5.1.1	Isochronous Receive	47
5.1.2	Isochronous Transmit	49
5.1.3	Asynchronous Receive	51
5.1.4	Asynchronous Transmit	52
5.2	Data-Mover Modes of Operation	54
5.2.1	Isochronous Transmit With Automatic Header Insertion	55
5.2.2	Isochronous Transmit Without Automatic Header Insertion	56
5.2.3	Isochronous Packet Receive Without Header and Trailer Removal	57
5.2.4	Isochronous Packet Receive With Header and Trailer	58
5.2.5	Asynchronous Packet Transmit With Automatic Header Insertion	59
5.2.6	Asynchronous Packet Transmit Without Automatic Header Insertion	60
5.2.7	Asynchronous Packet Receive With Headers and Trailer	61
5.2.8	Asynchronous Packet Receive With Automatic Header and Trailer Removal	62
5.3	Data-Mover Byte Mode	62
5.4	Data-Mover Endian Swapping	62
5.5	Data-Mover Handshake Mode	63
5.6	Data-Mover Critical Timing	63
<b>6</b>	<b>FIFO Memory Access</b>	<b>65</b>
6.1	General	65
6.2	ATF Access	65
6.3	ATF Burst Access	66
6.4	General-Receive FIFO (GRF)	67
6.5	GRF Stored Data Format	67
<b>7</b>	<b>TSB12LV32 Data Formats</b>	<b>69</b>
7.1	Asynchronous Transmit/Receive (Microcontroller Interface/Data-Mover Port to/From TSB12LV32)	69
7.1.1	Quadlet Transmit	69
7.1.2	Block Transmit	70
7.1.3	Quadlet Receive	71
7.1.4	Block Receive	73
7.2	Isochronous Transmit (Data-Mover Port to TSB12LV32)	74
7.2.1	Isochronous Receive (TSB12LV32 to Microcontroller Interface/Data-Mover Port)	75
7.3	Phy Configuration	76
7.3.1	Extended Phy Packets	77
7.4	Receive Self-ID Packet	79
<b>8</b>	<b>TSB12LV32/Phy Interface</b>	<b>83</b>
8.1	Principles of Operation	83
8.2	TSB12LV32 Service Request	84
8.3	Status Transfer	87
8.4	Receive Operation	88
8.5	Transmit Operation	89
8.6	TSB12LV32/Phy Interface Critical Timing	91
<b>9</b>	<b>Electrical Characteristics</b>	<b>93</b>
9.1	Absolute Maximum Ratings Over Operating Free-Air Temperature Range	93
9.2	Recommended Operating Conditions	93
9.3	Electrical Characteristics Over Recommended Ranges of Supply Voltage and Operating Free-Air Temperature	94
<b>10</b>	<b>Mechanical Information</b>	<b>95</b>

## List of Illustrations

<i>Figure</i>	<i>Title</i>	<i>Page</i>
1–1	TSB12LV32 Functional Block Diagram	2
3–1	Microcontroller Byte Stack (Write) Operation	26
3–2	Microcontroller Byte Unstack (Read) Operation	27
3–3	Byte Handshake Read	28
3–4	Word Handshake Read	28
3–5	Byte Handshake Write	29
3–6	Word Handshake Write	30
3–7	Byte Fixed-Timing Read	31
3–8	Word Fixed-Timing Read	31
3–9	Byte Fixed-Timing Write	32
3–10	Word Fixed-Timing Write	33
3–11	GRF Read Access (Byte Fixed-Timing Mode)	34
3–12	GRF Read Access (Word Fixed-Timing Mode)	34
3–13	ColdFire Read	36
3–14	ColdFire Write	37
3–15	Microcontroller Timing	37
3–16	Big Endian Format	38
3–17	Little Endian Format	38
3–18	Little-Endian Data-Invariance Illustration Chart	39
3–19	Little-Endian Address-Invariance Illustration Chart	40
4–1	Link Core Components	41
5–1	A Typical System Diagram	45
5–2	Isochronous Transmit DM Flow Control (TSB12LV32 Transmit to 1394 Bus)	46
5–3	Transmit Data Path	46
5–4	Asynchronous Transmit DM Flow Control (TSB12LV32 Transmit to 1394 Bus) (DMASYNC = 1)	47
5–5	Isochronous Receive With Auto Header and Trailer Removal	48
5–6	Isochronous Receive With Header and Trailer	48
5–7	Isochronous Transmit With Auto Header Insertion	49
5–8	Isochronous Transmit Without Auto Header Insertion	50
5–9	Asynchronous Receive Without Header and Trailer Removal	51
5–10	Asynchronous Receive With Headers and Trailer	52
5–11	Asynchronous Transmit With Auto Header Insertion	53
5–12	Asynchronous Transmit Without Auto Header Insertion	54
5–13	Isochronous Transmit With Auto Header Insertion at 400 Mbps	55
5–14	Isochronous Transmit With Auto Header Insertion at 200 Mbps	55
5–15	Isochronous Transmit With Auto Header Insertion at 100 Mbps	56
5–16	Isochronous Transmit Without Auto Header Insertion	56
5–17	Isochronous Receive With Automatic Header and Trailer Removal	57
5–18	Isochronous Receive With Header and Trailer	58
5–19	Isochronous Receive With Header and Trailer at 200 Mbps	58
5–20	Asynchronous Quadlet Transmit With Automatic Header Insertion	59

5-21 Asynchronous Block Transmit With Automatic Header Insertion at 200 Mbps	59
5-22 Asynchronous Block Transmit With Automatic Header Insertion at 400 Mbps	59
5-23 Asynchronous Quadlet Transmit Without Automatic Header Insertion at 400 Mbps	60
5-24 Asynchronous Block Transmit Without Automatic Header Insertion at 400 Mbps	60
5-25 Asynchronous Quadlet Receive With Headers and Trailer at 400 Mbps	61
5-26 Asynchronous Block Receive With Headers and Trailer at 400 Mbps	61
5-27 Asynchronous Quadlet Receive With Automatic Header and Trailer Removal at 400 Mbps	62
5-28 Asynchronous Block Receive With Automatic Header and Trailer Removal at 400 Mbps	62
5-29 Endian Swapping in Byte Mode	62
5-30 Endian Swapping in Word Mode	62
5-31 Data-Mover Handshake Mode (GPLynx Mode)	63
5-32 Clock-to-Output Timing With Respect to DMCLK	63
6-1 TSB12LV32 Controller-FIFO-Access Address Map	65
6-2 Asynchronous Packet With N Quadlets (ATF Loading Operation)	65
7-1 Quadlet Transmit Formats	69
7-2 Block Transmit Format	70
7-3 GRF Quadlet-Receive Format	71
7-4 Data-Mover Quadlet-Receive Format	72
7-5 GRF Block-Receive Format	73
7-6 Data-Mover Block-Receive Format	73
7-7 Isochronous Transmit Format	74
7-8 Data-Mover Isochronous Receive Format	75
7-9 GRF Isochronous Receive Format	75
7-10 Phy Configuration Packet Format	76
7-11 Receive Phy Configuration Packet Format	76
7-12 Ping Packet Format	77
7-13 Remote Access Packet Format	77
7-14 Remote Command Packet Format	78
7-15 Resume Packet Format	78
7-16 Receive Self-ID Packet Format (RXSID = 1, FULLSID = 1)	79
7-17 Receive Self-ID Packet Format (RXSID = 1, FULLSID = 0)	79
7-18 Phy Self-ID Packet #0 Format	80
7-19 Phy Self-ID Packet #1 Format	80
7-20 Phy Self-ID Packet #2 Format	80
8-1 Phy-LLC Interface	83
8-2 LREQ Request Stream	84
8-3 Status Transfer Timing	87
8-4 Normal Packet Reception Timing	88
8-5 Null Packet Reception Timing	89
8-6 Normal Packet Transmission Timing	90
8-7 Critical Timing for the TSB12LV32/Phy Interface	91

---

## List of Tables

<i>Table</i>	<i>Title</i>	<i>Page</i>
1-1	Terminal Functions	4
1-2	STAT Terminal Programming	6
2-1	Configuration Register (CFR) Map	7
2-2	Header/Trailer Usage for CFRs 38th–48h	8
3-1	Microcontroller Interface Modes of Operation	25
3-2	TSB12LV32 MP/MC Interface Terminal Function Matrix	25
3-3	Microcontroller Timing	38
3-4	Endian Swapping Operations	39
4-1	Receiver Routing	43
5-1	Modes of Operation	55
5-2	CLK-to-Output Timing With Respect to DMCLK	63
6-1	Packet Token Definition	67
7-1	Quadlet Transmit Format Functions	70
7-2	Block Transmit Format Functions	71
7-3	Quadlet Receive Format Functions	72
7-4	Block Receive Format Functions	74
7-5	Isochronous Transmit Functions	75
7-6	Isochronous Receive Functions	75
7-7	Phy Configuration Packet Functions	76
7-8	Receive Phy Configuration Packet	76
7-9	Ping Packet Fields	77
7-10	Remote Access Packet Fields	77
7-11	Remote Command Packet Fields	78
7-12	Resume Packet Fields	78
7-13	GRF Receive Self-ID Setup Using Control Register Bits (RXSID and FULLSID)	79
7-14	Receive Self-ID Function	79
7-15	Phy Self-ID Packet Fields	81
8-1	CTL Encoding When the Phy Has Control of the Bus	84
8-2	CTL Encoding When the TSB12LV32 Has Control of the Bus	84
8-3	Request Stream Bit Length	85
8-4	Request Type Encoding	85
8-5	Bus Request	85
8-6	Bus Request Speed Encoding	85
8-7	Read Register Request	85
8-8	Write Register Request	86
8-9	Acceleration Control Request	86
8-10	Status Bits	87
8-11	Receive Speed Codes	89
8-12	TSB12LV32/Phy Interface Timing	91



# 1 Overview

## 1.1 TSB12LV32 Description

The TSB12LV32 (GP2Lynx) is a high-performance general-purpose IEEE 1394a-2000 link-layer controller (LLC) with the capability of transferring data between the 1394 Phy-link interface, an external host controller, and an external device connected to the data-mover port (local bus interface). The 1394 Phy-link interface provides the connection to a 1394 physical layer device and is supported by the LLC. The LLC provides the control for transmitting and receiving 1394 packet data between the microcontroller interface and the Phy-link interface via internal 2K byte FIFOs at rates up to 400 Mbps. The TSB12LV32 transmits and receives correctly formatted 1394 packets, generates and detects the 1394 cycle start packets, communicates transaction layer transmit requests to the Phy, and generates and inspects the 32-bit cyclic redundancy check (CRC).

The TSB12LV32 is capable of being 1394 cycle master (CM), 1394 bus manager, 1394 isochronous resource manager (IRM) if additional control status registers (CSRs) are added via the external host controller, and supports reception of 1394 isochronous data on two channels and transmission of 1394 isochronous data on four channels.

The TSB12LV32 supports a direct interface to many microprocessors/microcontrollers by including programmable endian swapping. TSB12LV32 has a generic 16-/8-bit host bus interface which includes support for a ColdFireE microcontroller mode at rates up to 60 MHz. The microcontroller interface can operate in byte or word (16 bit) accesses.

The data-mover block in GP2Lynx handles the external memory interface of large data blocks. This local bus interface can be configured either to transmit or receive data packets. The packets can be either asynchronous, isochronous, or asynchronous streaming data packets. The data-mover (DM) port can receive any type of packet, but it can only transmit one type of packet at a time: isochronous data packets, asynchronous data packets, or asynchronous stream data packets.

The internal FIFO is separated into an asynchronous transmit FIFO (ATF) and a general receive FIFO (GRF), each of 520 quadlets (2K bytes). Asynchronous and/or isochronous receive packets can be routed to either the DM port or the GRF via the receiver routing control logic. Asynchronous data packets or asynchronous stream data packets can be transmitted from the DM port or the internal FIFO: ATF. If there is contention the ATF has priority and is transmitted first. Isochronous packets can only be transmitted by the data-mover port.

The LLC also provides the capability to receive status information from the physical layer device and to access the physical layer control and status registers by the application software.

## 1.2 TSB12LV32-EP Features

- Controlled Baseline
- One Assembly/Test Site, One Fabrication Site
- Extended Temperature Performance of  $-40^{\circ}\text{C}$  to  $110^{\circ}\text{C}$
- Enhanced Diminishing Manufacturing Sources (DMS) Support
- Enhanced Product Change Notification
- Qualification Pedigree<sup>†</sup>
- Compliant With IEEE 1394-1995 Standards and 1394a-2000 Supplement for High Performance Serial Bus<sup>‡</sup>
- Supports Transfer Rates of 400, 200, or 100 Mbps
- Compatible With Texas Instruments Physical Layer Controllers (Phys)
- Supports the Texas Instruments Bus Holder Galvanic Isolation Barrier

<sup>†</sup>Component qualification in accordance with JEDEC and industry standards to ensure reliable operation over an extended temperature range. This includes, but is not limited to, Highly Accelerated Stress Test (HAST) or biased 85/85, temperature cycle, autoclave or unbiased HAST, electromigration, bond intermetallic life, and mold compound life. Such qualification testing should not be viewed as justifying use of this component beyond specified performance and environmental limits.

<sup>‡</sup>Implements technology covered by one or more patents of Apple Computer, Incorporated and SGS Thomson, Limited.

ColdFire is a trademark of Motorola, Inc.



- 2K byte General Receive FIFO (GRF) Accessed Through Microcontroller Interface Supports Asynchronous and Isochronous Receive.
- 2K byte Asynchronous Transmit FIFO (ATF) Accessed Through Microcontroller Interface Supports Asynchronous Transmissions.
- Programmable Microcontroller Interface With 8-Bit or 16-Bit Data Bus, Multiple Modes of Operation Including Burst Mode, and Clock Frequency to 60 MHz
- 8-Bit or 16-Bit Data-Mover Port (DM Port) Supports Isochronous, Asynchronous, and Asynchronous Streaming Transmit/Receive From an Unbuffered Port at a Clock Frequency of 25 MHz.
- Backward Compatible With All TSB12LV31(GPLynx) Microcontroller and Data-Mover Functionality in Hardware
- Two-Channel Support for Isochronous Receive to Unbuffered 8/16 Data-Mover Port
- Four-Channel Support for Isochronous Transmit From Unbuffered 8/16 Bit Data-Mover Port
- Single 3.3-V Supply Operation With 5-V Tolerance Using 5-V Bias Terminals
- High Performance 100-Pin PZ Package

### 1.3 Functional Block Diagram

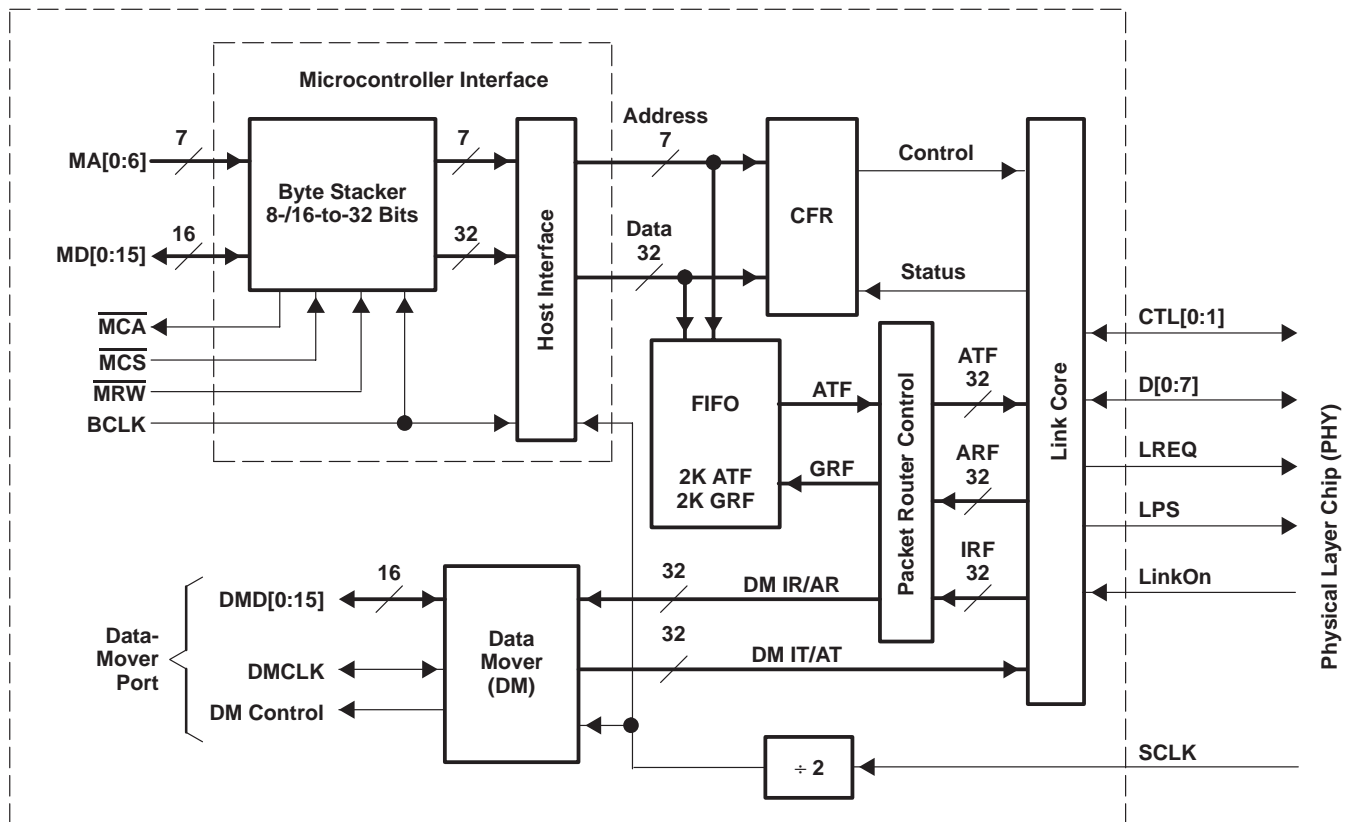
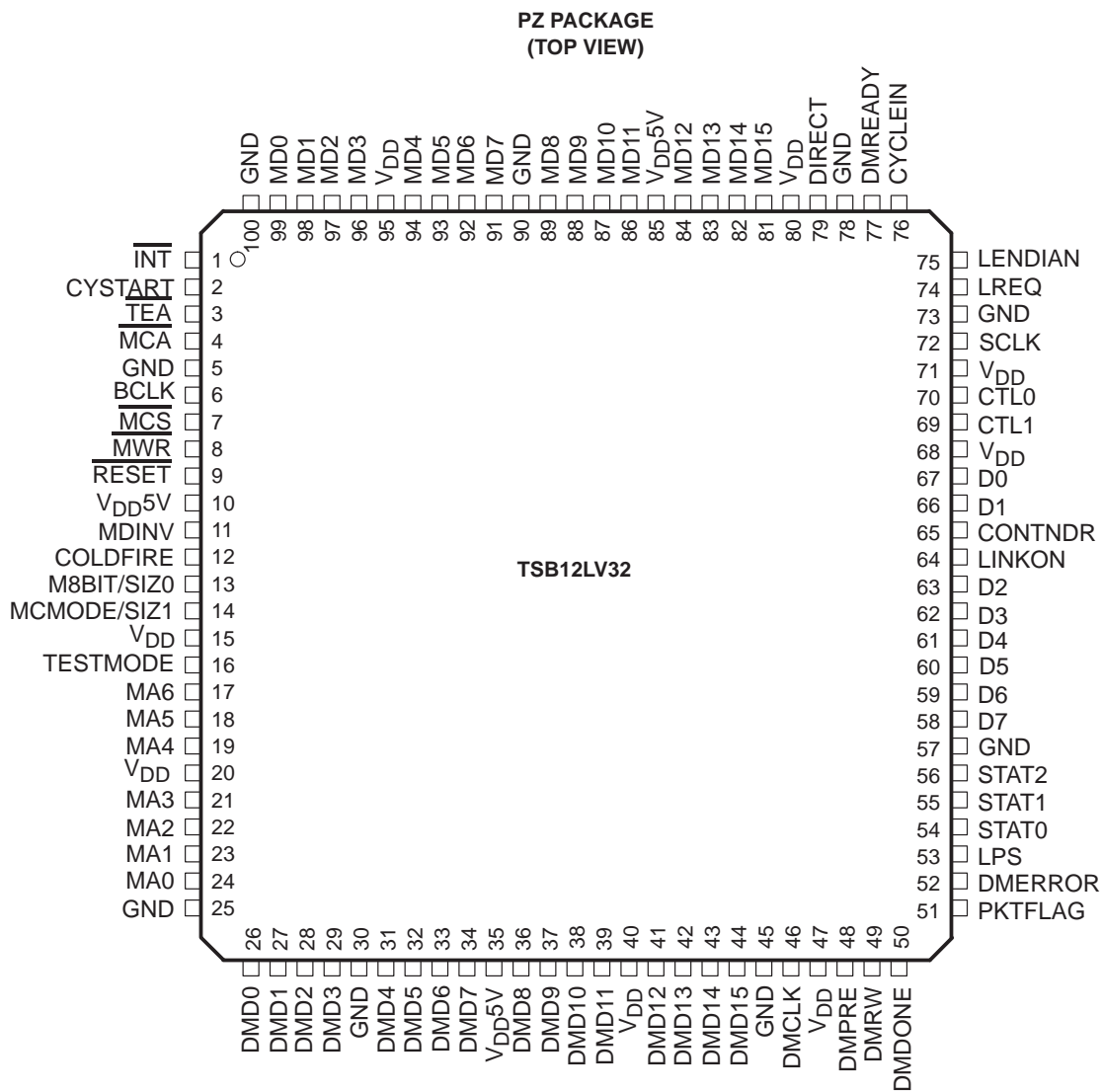

Figure 1-1. TSB12LV32 Functional Block Diagram

## 1.4 Terminal Assignments



## 1.5 Terminal Functions

The terminal functions are described in Table 1–1. No input terminals or I/O terminals should be left floating; unless otherwise specified, connect any unused input terminals or I/O terminals to ground using 1-k $\Omega$  resistors.

**Table 1–1. Terminal Functions**

TERMINAL NAME	NO.	I/O	DESCRIPTION
<b>Microcontroller/Microprocessor Interface</b>			
BCLK	6	I	Microcontroller interface clock. Maximum frequency is 60 MHz. In the ColdFire mode, BCLK is the same as CLK, which is the clock-input signal to the ColdFire.
COLDFIRE	12	I	ColdFire mode. To operate in this mode, COLDFIRE must be asserted high.
LENDIAN	75	I	Little-endian mode for the microcontroller interface. When this terminal is pulled up, the data on MD0–MD15 is byte-swapped to little endian byte format before it is written to the CFR or FIFO and after it is read from the CFR or FIFO.
MA[0:6]	24–21 19–17	I	Microcontroller address bus. MA0 is the most significant bit (MSB) of these 7 bits.
M8BIT/SIZ0	13	I	Configuration bit for microcontroller interface. If the microcontroller interface is 8 bits wide, this terminal must be pulled up to the supply voltage. In ColdFire mode, this terminal represents burst SIZ0.
MCMODE/SIZ1	14	I	Mode bit for microcontroller interface. If the microcontroller interface is used in a handshake mode, this terminal must be pulled up to the supply voltage. In ColdFire mode, this terminal represents burst SIZ1.
$\overline{MCA}$	4	O	Microcontroller interface cycle acknowledge. When asserted low, $\overline{MCA}$ signals an acknowledge of the microcontroller cycle from the TSB12LV32.
$\overline{MCS}$	7	I	Microcontroller interface cycle start. When asserted low, $\overline{MCS}$ signals the beginning of a microcontroller operation to the TSB12LV32.
MDINV	11	I	Microcontroller interface data invariant mode. This terminal is meaningful only when LENDIAN (75) is high. When asserted high, the microcontroller interface operates in the data invariant mode. When low, the microcontroller interface operates in address invariant mode.
MD[0:15]	99–96 94–91 89–86 84–81	I/O	Microcontroller interface bidirectional data bus. MD0 is the most significant bit. However, byte significance is dependent on the state of the LENDIAN and MDINV terminals.
$\overline{MWR}$	8	I	Microcontroller read/write indicator. When driven high, $\overline{MWR}$ indicates a read access from the TSB12LV32. When driven low, $\overline{MWR}$ indicates a write access to the TSB12LV32.
$\overline{TEA}$	3	O	Transfer error acknowledge. This active-low signal is asserted low for one BCLK cycle whenever there is an illegal transfer request by the microcontroller (i.e., requested data transfer size is unsupported or MCS is asserted low for more than one BCLK cycle in ColdFire mode).
<b>Data-Mover Port Interface</b>			
DMD[0:15]	26–29 31–34 36–39 41–44	I/O	Data-mover (DM) bidirectional data port. DMD0 is the MSB of these 16 bits.
DMCLK	46	O	Data-mover clock at (SCLK/2) MHz
DMDONE	50	O	Data mover done. For transmit, this signal is activated when the internal packet counter counts down to zero from the value loaded into the PACKET PER BLOCK field in the CFR @ 04h. For receive, this terminal pulses for one DMCLK prior to the first byte/word available to the DM interface.
DMERROR	52	O	Data-mover error. DMERROR is asserted high when there is an error in the received packet or an illegal transmit speed was attempted.
DMPRE	48	O	Data-mover predata indicator. In transmit mode, DMPRE pulses for one DMCLK prior to accepting the first quadlet on the DM port. In isochronous receive mode, DMPRE pulses for one DMCLK when the sync bit in the header matches a bit set in the isochronous port CFR at 18h. <i>DMPRE is not used in asynchronous receive mode.</i>
DMREADY	77	I	Data mover ready. Must be asserted high by the external logic controlling the DM interface when data is ready for transmit. DMREADY must be set low when the data mover is in receive mode. DMREADY cannot be used to throttle the data rate through the data-mover port; see Section 5 for more information.

Table 1–1. Terminal Functions (Continued)

TERMINAL NAME	NO.	I/O	DESCRIPTION
<b>Data-Mover Port Interface (Continued)</b>			
DMRW	49	O	Data-mover read/write indicator. When data is being moved from 1394 to the DM port (receive) this signal goes high to indicate data is available on DMD[0:15]. When data is being moved from DM to 1394 bus (transmit) this signal goes high to indicate that data must be supplied to the DMD[0:15] port for transmission.
PKTFLAG	51	O	Packet flag. PKTFLAG is asserted high to indicate the first (header) or last (trailer) quadlet of a received packet on the DM interface. PKTFLAG is not valid in transmit mode. The PKTFLAG signal is not valid when the header/trailer extraction option is selected.
<b>Phy/Link Interface</b>			
CTL[0:1]	70, 69	I/O	Phy-link interface control lines
D[0:7]	67, 66, 63–58	I/O	Phy-link interface data lines. Data is only expected on D0 and D1 at 100 Mbps, D0–D3 at 200 Mbps, and D0–D7 at 400 Mbps. D0 is the MSB bit.
LINKON	64	I	Link-on from the Phy is a 4 MHz – 8 MHz clock. This signal is activated when the link is inactive and the Phy has detected a link-on packet or a Phy interrupt. This clock persists for no more than 500 ns. When the link detects this terminal as active, it turns on and drives LPS.
LPS	53	O	Link power status. LPS is used to drive the LPS input of the Phy. It indicates to the Phy that the link is powered up and active. LPS toggles at a rate = 1/16 of BCLK by default (see CFR at 08h for more information).
LREQ	74	O	Link request to Phy. LREQ makes bus requests and register access requests to the Phy.
SCLK	72	I	System clock. SCLK is a 49.152-MHz clock supplied by the Phy. DMCLK is generated from SCLK. SCLK can also be used as the source for BCLK.
<b>Miscellaneous Functions</b>			
CONTNDR	65	I/O	Contender. When asserted high, this terminal tells the link that this node is a contender for isochronous resource manager (IRM) or bus manager functions. The state of CONTNDR must match the state of the Phy contender terminal for 1394-1995 compliant Phys, and the Phy register bit for 1394a–2000 compliant Phys. This terminal defaults to being an input on power up. After power up, the value of this terminal can be driven internally by the CTNDRSTAT bit (bit 12 at 08h). Additional CSRs must be implemented in software for the device to support IRM functionality.
CYCLEIN	76	I	Cycle in. This input is an optional external 8-kHz clock used as the isochronous cycle clock. It only is used if attached to the cycle-master node. It is enabled by the cycle source bit and should be tied high when not used.
CYSTART	2	O	Isochronous cycle start indicator. CYSTART signals the beginning of an isochronous cycle by pulsing for one DMCLK period.
DIRECT	79	I	Isolation terminal. When this terminal is asserted high, no isolation is present between the TSB12LV32 and the Phy. When low, the Texas Instruments bus holder isolation is active.
GND	5, 25, 30, 45, 57, 73, 78, 90, 100		Ground reference
$\overline{\text{INT}}$	1	O	Interrupt. NOR of all internal interrupts.
$\overline{\text{RESET}}$	9	I	System reset. This active-low signal is asynchronous to the TSB12LV32.
STAT[0:2]	54–56	O	General status outputs. STATn is the output signal selected with the CFR at address 20h.
TESTMODE	16	I	This terminal is used to place the TSB12LV32 in the test mode (for Texas Instruments internal use only). In normal operation, this terminal must be tied to ground.
V <sub>DD5V</sub>	10, 35, 85		5 V ( $\pm 0.5$ V) supply voltage for 5-V tolerant inputs. Only the Phy/link interface of the TSB12LV32 is <b>not</b> 5-V tolerant. Tie this terminal to the 3.3-V supply voltage if the TSB12LV32 is not connected to any devices driving 5-V signals. Tie this terminal to the 5-V supply voltage if the TSB12LV32 is connected to any devices driving 5-V signals. This terminal is only used to make inputs 5-V tolerant, it is not used for any outputs.
V <sub>DD</sub>	15, 20, 40, 47, 68, 71, 80, 95		3.3 V ( $\pm 0.3$ V) supply voltage

## 1.5.1 STAT0, STAT1, and STAT2 Programming

The STAT0, STAT1, and STAT2 terminals can be independently programmed to show one of 14 possible internal hardware status signals. The controls for the STAT terminals are in the *Diagnostic* register at address 20h of the CFR register. STAT0 is controlled by STATSEL0 (bits 16-19), STAT1 is controlled by bits STATSEL1 (bits 20–23), and STAT2 is controlled by STATSEL2 (bits 24–27). See Table 1–2 for programming the STAT terminals.

**Table 1–2. STAT Terminal Programming**

STATSEL0, STATSEL1, OR STATSEL2				STAT0/STAT1/STAT2	DESCRIPTION
0	0	0	0	Reserved	Reserved
0	0	0	1	ATFFULL	Indicates that the ATF is full. Bit 12 in the FIFO status CFR at 30h.
0	0	1	0	Bus reset (PHYRST)	1394 bus reset. Bit 3 in the Interrupt CFR at 0Ch.
0	0	1	1	Arbitration reset gap	The 1394 bus has been idle for an arbitration reset gap. Bit 26 in the interrupt CFR at 0Ch.
0	1	0	0	CYCLEOUT	Cycle out. The LLC clock. It is based on the timer controls and the received cycle-start messages.
0	1	0	1	RXDMPKT	Packet received to DM interrupt. Activated at the end of a received packet. Bit 9 in the interrupt CFR at 0Ch.
0	1	1	0	RXGRFPKT	Packet received to GRF interrupt. Activated at the end of a received packet. Bit 6 in the interrupt CFR at 0Ch.
0	1	1	1	BX_BUSY	Byte busy. This represents the OR of bits 0–3 of the diagnostic CFR at 20h.
1	0	0	0	SUBGP	Subaction gap. Activated upon detection of a subaction gap. Bit 27 in the interrupt CFR at 0Ch.
1	0	0	1	CYCLE_DONE	Cycle done. Indicates the end of the isochronous period. This happens when a subaction gap has been detected. Bit 22 in the interrupt CFR at 0Ch.
1	0	1	0	ATSTARTED (default setting for STAT1)	Activated when an asynchronous packet transfer has started from the ATF. Bit 5 in the interrupt CFR at 0Ch.
1	0	1	1	DMACKERR	DM acknowledge was not complete. Bit 17 in the interrupt CFR at 0Ch.
1	1	0	0	DMEN	DM enable. Bit 26 in the DM control CFR at 04h.
1	1	0	1	GRFEMPTY (default setting for STAT2)	GRF is empty. Bit 15 in the FIFO status CFR at 30h.
1	1	1	0	Reserved	Reserved
1	1	1	1	Reserved	Reserved

NOTE: An interrupt remains set until cleared by writing a 1 to the interrupt CFR at 0Ch, but the associated STAT signal pulses for only one clock cycle.

## 1.6 Ordering Information

TEMPERATURE	ORDERING NUMBER	TOP-SIDE MARKING	PACKAGE
–40°C to 110°C	TSB12LV32TPZEP	TSB12LV32TEP	100-Terminal PQFP

## 2 Internal Registers

### 2.1 TSB12LV32 Configuration Registers

Table 2–1. Configuration Register (CFR) Map

	MSB																															LSB											
	0	1	2	3	4	5	6	7	8	9	10	11	12	13	14	15	16	17	18	19	20	21	22	23	24	25	26	27	28	29	30	31											
00h	0	1	1	1	0	0	0	1	0	0	0	0	1	0	1	0	0	0	1	1	1	0	0	0	1	0	1	0	0	0	0	0	0	VERSION (711538A0h)									
04h	PACKET PER BLOCK													ENDSWAP	BYTEMODE	HANDSHK	AUTOUP	DMACK					SPEED		CHNLCNT	DMEN	DMHDR	ARO	AR1	DMASYN	DMRX	DM Control											
08h	FLSHERR	RXSLD	FULLSID	PHY_PKT_ENA	BSYCTL	TXEN	RXEN	ENA_ACCEL	ENA_CONCAT	ENA_INSERT_IDLE	RSTTX	RSTRX	CTNDRSTAT	CTNDRISIN		BUSNRST	BDIV0	BDIV1	DMACKCOMP	FIFOACKCOMP	CYMAS	CYSRC	CYTEN	CLSIDER	ERR_SID_CODE			CMAUTO	IRP1EN	IRP2EN		Control											
0Ch	INT	PHINT	PHRRX	PHRST	SELFIDEND	ATSTARTED	RXGRFPKT	CMDRST	DMERROR	RXDMPKT	SELFIDER	LINKON	ATSTK	ATFEMPTY	SNTRJ	HDRERR	TCERR	DMACKERR	FIFOACK	MCERROR	CYSEC	CYST	CYDNE		CYLST	CARBFL	ARBGP	SUBGP			IARBF	IARBF	Interrupt										
10h	INT	PHINT	PHRRX	PHRST	SELFIDEND	ATSTARTED	RXGRFPKT	CMDRST	DMERROR	RXDMPKT	SELFIDER	LINKON	ATSTK	ATFEMPTY	SNTRJ	HDRERR	TCERR	DMACKERR	FIFOACK	MCERROR	CYSEC	CYST	CYDNE		CYLST	CARBFL	ARBGP	SUBGP			IARBF	IARBF	Interrupt Mask										
14h	SECONDS COUNT						CYCLE COUNT						CYCLE OFFSET																						Cycle Timer								
18h	TAG1		IRPORT1				TAG2		IRPORT2										ISYNCRCVN	IRCVALL																	ISOCHRONOUS Port						
1Ch	E_HCRC	E_DCRC	NO_PKT	F_ACK	NO_ACK	ACK						PING VALUE																									Maint_Control						
20h	B0_BUSY	B1_BUSY	B2_BUSY	B3_BUSY	B0_PND	B1_PND	B2_PND	B3_PND	RAM_TEST	REGRW							STATSEL0	STATSEL1	STATSEL2																					Diagnostic			
24h	RDPHY	WRPHY	PHYRGAD				PHYRGDATA										PHYRXAD	PHYRXDATA																					Phy Access				
28h–2Ch																																Reserved											
30h	ATFCLR	ATFWBMTY	ATFAVAIL										ATFFULL	GRFCLR	GRFEMPTY	CD	ATAK				GRFUSED																						FIFO Status
34h	NRIDVAL	NODECNT						ROOT	CONTENDER	IRMNODEID				BUS NUMBER				NODE NUMBER																					Bus Reset				
38h	(See Section 2.2.13)																															Header0											
3Ch	(See Section 2.2.14)																															Header1											
40h	(See Section 2.2.15)																															Header2											
44h	(See Section 2.2.16)																															Header3											
48h	NUMBER OF QUADLETS													ACKCODE					SPD		LPS_RESET	LPS_OFF																	Trailer				
4Ch	ASYNC RETRY COUNT						RETRY INTERVAL																															Asynchronous Retry					

NOTES: A. All dark gray areas (bits) are reserved bits.  
 B. All light gray areas are read-only bits. All remaining are read/write bits.

**Table 2–2. Header/Trailer Usage for CFRs 38h–48h**

DIRECTION OF DM DATA TRANSFER	PACKET TYPE	AUTO HEADER/TRAILER INSERT/EXTRACT	HEADER/TRAILER REGISTER
Data-Mover TRANSMIT (to 1394 Bus)	Isochronous	YES	Header0 CFR is formatted for isochronous transmission. Header1–header3 CFRs can be used for additional channels.
		NO	Isochronous header is supplied by the external device on the DM interface. The header0 CFR is automatically written with the isochronous header extracted from the transmitted packet.
	Asynchronous/asynchronous stream packets	YES	Header0–header3 CFRs are formatted for asynchronous transmission.
		NO	Asynchronous header is supplied by the external device on the DM interface. The header0–header3 CFRs are automatically written with the header extracted from the transmitted packet.
Data-Mover RECEIVE (from 1394 Bus)	Isochronous/asynchronous stream packets	YES	Header0–header3 CFRs and trailer CFR are automatically updated. Isochronous headers are not streamed through the DM port. The trailer quadlet is removed from the data stream.
		NO	Header0–header3 CFRs and trailer CFR are automatically updated. The isochronous header is streamed through the DM port along with the payload data. The trailer quadlet is appended to the data stream.
	Asynchronous	YES	Header0–header3 CFRs and trailer CFR are automatically updated. Asynchronous headers are not streamed through the DM port. The trailer quadlet is removed from the data stream.
		NO	Header0–header3 CFRs and trailer CFR are automatically updated. Asynchronous headers are streamed through the DM port along with data. The trailer quadlet is appended to the data stream.

## 2.2 Configuration Register Definitions

### 2.2.1 Version Register at 00h

0	1	2	3	4	5	6	7	8	9	10	11	12	13	14	15	16	17	18	19	20	21	22	23	24	25	26	27	28	29	30	31
0	1	1	1	0	0	0	1	0	0	0	1	0	1	0	1	0	0	1	1	1	0	0	0	1	0	1	0	0	0	0	0

This register uniquely identifies this device to the software. The value is fixed at 7115 38A0h. This register is read only.

### 2.2.2 Data-Mover Control Register at 04h

0	1	2	3	4	5	6	7	8	9	10	11	12	13	14	15	16	17	18	19	20	21	22	23	24	25	26	27	28	29	30	31
PACKET PER BLOCK												ENDSWAP	BYTEMODE	HANDSHK	AUTOUP	DMACK					SPEED	CHNL CNT	DMEN	DMHDR	ARO	AR1	DMASYN	DMRX			

This register controls the data-mover port and must be set up before using the port. The power-up reset value of this register equals 0000 0000h.

BIT NUMBER	BIT NAME	FUNCTION	DIR	DESCRIPTION
0–11	PACKET PER BLOCK	Data packets per block transfer	R/W	Number of data packets per block transfer. A block transfer is made up of multiple data packets. A packet is the size of the data payload and is specified as part of the header. This field remains fixed throughout the block transfer; it does not count down. It does not change value until rewritten or reset. The data-mover logic uses this value to activate DMDONE. In asynchronous mode, this field states how many packets the DM should transfer before checking the status of DMREADY again. In isochronous mode, this field states how many isochronous packets should be sent in the DM cycle. These packets are sent over multiple channels if more than one isochronous channel is active. The block transfer may take more than one isochronous cycle. This field is only used in transmit mode.
12	ENDSWAP	Endian swap	R/W	Swap endian. When this bit is set, the quadlet formed by stacking the DM data is byte reversed, (i.e. the quadlet formed by fetching doublet AB01 then CD02 is 02CD 01AB instead of AB01 CD02).

BIT NUMBER	BIT NAME	FUNCTION	DIR	DESCRIPTION
13	BYTEMODE	Byte mode	R/W	Byte mode. When this bit is set the DM port only looks at DM0–DM7. DM8–DM15 are ignored for transmit and are not driven on receive. In this mode, the maximum speed supported on the 1394 bus is 200 Mbps.
14	HANDSHK	Handshake mode (GPLynx mode)	R/W	Handshake. When this bit is set, DMREADY and DMDONE are in strict handshake mode (i.e., TSB12LV31 compatible mode). DMREADY must not be deactivated until DMDONE activates. When DMDONE goes high, it checks for DMREADY low as an acknowledge. When this bit is set to 0, DMREADY may be deactivated before DMDONE activates.
15	AUTOUP	Automatic address update	R/W	Automatic update offset address. Valid only for asynchronous transmit using header insert mode (bit 27, DMHDR, set to 0). For write request asynchronous packets, header quadlet 2 contains the destination offset low address for the write. When this bit is set, header quadlet 2 is updated by the value of the payload size (rounded up to the nearest quadlet boundary).
16–20	DMACK	DM acknowledge	R	DM acknowledge. This is the acknowledge received from the receiving node. This is updated only when the transfer is from the DM port.
21	RESERVED			Reserved
22–23	SPEED	DM speed code	R/W	Speed code. This field is valid for isochronous transmit and asynchronous transmit through the DM port. The DM logic uses this field to specify to the Phy the speed of the data transfer.
24–25	CHNLCNT	Channel count	R/W	Channel count. This field is valid only in isochronous transmit mode. This field allows the node to transmit multiple data packets during a single isochronous period. The device expects to transmit a packet on every active channel during each isochronous cycle. If valid data is not provided, the value on the DM port is latched and sent. Each packet must have a different channel number, however, hardware does not check this. When the isochronous transmit header is supplied by the DM interface or automatically inserted by the hardware, a maximum of four different channels can be accessed in one isochronous period. In isochronous transmit with automatic header insert, Header0–Header3 CFRs are used as the isochronous header registers.  CHNLCNT = 00b, one channel / one packet per cycle CHNLCNT = 01b, two channels / two packets per cycle CHNLCNT = 10b, three channels / three packets per cycle CHNLCNT = 11b, four channels / four packets per cycle
26	DMEN	DM enable	R/W	DMEN controls the transmission of packets (asynchronous or isochronous) from the DM port. If this bit is 0, transmission through from the DM port is inhibited. This bit is typically used for asynchronous flow control. In normal operation, if an asynchronous packet transmitted from the DM port receives an acknowledge from the receiving node other than <i>ack complete</i> , this bit is set to 0 and DMERROR is asserted high. Software must set this bit high to allow further transmission of asynchronous packets from the DM port. The default and power-up value is 0.
27	DMHDR	DM header insert control	R/W	DM header insert bit. When this bit is set to 0, the hardware automatically inserts the header(s) into the DM transmit data. During receive, setting this bit to 0 strips off the header(s)/trailer before routing packet to the DM. Header(s)/trailer are always written to the CFR header/trailer registers regardless of the value of DMHDR.
28–29	AR0, AR1	Receive control routing	R/W	Receive packet routing control encoded bits. These bits in conjunction with DMASYNC and DMRX, bits 30 and 31 in the DM control register, control the routing of received packets to either the data-mover port or to the GRF. See Table 4–1.
30	DMASYNC	DM asynchronous	R/W	If this bit is set to 1, the DM port is configured to transmit asynchronous traffic only. If this bit is set to 0, the DM port is configured to transmit isochronous traffic only. The DM port can not transmit both asynchronous and isochronous traffic simultaneously. It must be configured for asynchronous (DMASYNC = 1) or isochronous (DMASYNC = 0). The DM port can receive asynchronous and isochronous data packets simultaneously. See Table 4–1 for more information.
31	DMRX	DM receive	R/W	If this bit is set to 1, the DM port is configured to receive. If this bit is set to 0, the DM port is configured to transmit. The DM port cannot both transmit and receive data at the same time, it must be configured for either transmit or receive. See Table 4–1 for more information.



## 2.2.3 Control Register at 08h

0	1	2	3	4	5	6	7	8	9	10	11	12	13	14	15	16	17	18	19	20	21	22	23	24	25	26	27	28	29	30	31
FLSHERR	RXSID	FULLSID	PHY_PKT_ENA	BSYCTRL	TXEN	RXEN	ENA_ACCEL	ENA_CONCAT	ENA_INSERT_IDLE	RSTTX	RSTRX	CTNDRSTAT	CTNDRISIN		BUSNRST	BDIV0	BDIV1	DMACKCOMP	FIFOACKCOMP	CYMAS	CYSRC	CYTEN	CLSLIDER	SID ERROR CODE				CMAUTO	IRP1EN	IRP2EN	

The control register dictates the basic operation of the TSB12LV32. The power-up reset value of this register equals E004 0200h.

BIT NUMBER	BIT NAME	FUNCTION	DIR	DESCRIPTION
0	FLSHERR	Flush GRF on error	R/W	This bit controls the flushing of the GRF when a packet with a data CRC error is detected. The power-up value is 1, which means flush the GRF when a data CRC error is detected.
1	RXSID	Receive self-ID packets	R/W	If this bit is set, the self-identification (SID) packets generated by 1394 Phy devices during the bus initialization phase are received and placed into the GRF as a single packet. The default setting of this bit is 1. When this bit is set to 0, the SIDs are not placed into the GRF. This bit must be set to 1 for the SELFIDEND interrupt to function.
2	FULLSID	Save full self-ID packet in GRF	R/W	Save the full self-ID packets. When this bit is 1, the self-ID data quadlet and its inverse quadlet are saved in the GRF. When this bit is 0, only the self-ID data quadlet is saved in the GRF.
3	PHY_PKT_ENA	Phy packets receive enable	R/W	Phy packet enable allows reception of all Phy packets. If this bit is set to 0, all Phy packets, except for self-IDs, are rejected and interrupt HDERR (if not masked) is generated. One HDERR interrupt is generated for every Phy packet received.
4	BSYCTRL	Busy control	R/W	BSYCTRL controls which busy status the device returns to incoming packets. When this bit is 0, the device follows normal busy/retry protocol: only send busy when necessary. When this bit is 1, the device sends a busy acknowledge to all incoming packets .
5	TXEN	Transmit enable	R/W	When TXEN is cleared, the 1394 transmitter does not arbitrate or send packets. TXEN bit is cleared following a bus reset, and all traffic through the DM port is interrupted. TXEN must be set before packet transmit can resume. The power-on reset value of TXEN is 0. If the TXEN bit is not set after a bus reset when the node is master, the CYSTART terminal does not toggle.
6	RXEN	Receive enable	R/W	When RXEN is cleared, the 1394 receiver does not receive any packets. This bit is not affected by a bus reset and is set to 0 after a power-on reset.
7	ENA_ACCEL	Acceleration enable	R/W	Enable acceleration. When this bit is set, fly-by acceleration and accelerated arbitration are enabled. This bit cannot be set while TXEN and RXEN are set. This bit can only be used with a 1394a-2000 capable Phy.
8	ENA_CONCAT	Concatenation enable	R/W	Enable concatenation. When this bit is set it allows the link to concatenate multiple isochronous or asynchronous packets. This bit can only be used with a 1394a-2000 capable Phy.
9	ENA_INSERT_IDLE	Insert idle enable	R/W	Per the 1394a-2000 specification, the link is required to insert an idle state on the control lines after the Phy grants the link control of the Phy/link interface. If using a 1394a-2000 Phy, this bit should be set to 1 in order for the link to drive an idle state following the grant state from the Phy. For 1394-1995 Phys this bit must remain low.
10	RSTTX	Transmitter reset	R/W	When RSTTX is set, the entire transmitter resets synchronously. This bit clears itself.
11	RSTRX	Receiver reset	R/W	When RSTRX is set, the entire receiver resets synchronously. This bit clears itself.
12	CTNDRSTAT	Contender status	R/W	Contender status. On power up, this bit reflects the status of the CONTNDR pin. When bit 13, CTNDRISIN, is 0 this bit is driven out to the CONTNDR pin. If CTNDRISIN is 1 this bit is not used. (Only use on 1394-1995 Phys, or 1394a-2000 Phys when using hardware reset; otherwise, use the 1394a-2000 Phy registers to set the node contender status).
13	CTNDRISIN	Contender driver enable	R/W	Driver enable for the CONTNDR pin. On power up this bit is set to 1, which disables the driver and allows reading of the state of the CONTNDR pin. Writing a 0 to this bit enables the driver and drives bit 12, CTNDRSTAT, to output on the CONTNDR pin.
14	RESERVED			Reserved

BIT NUMBER	BIT NAME	FUNCTION	DIR	DESCRIPTION		
15	BUSNRST	Bus number reset enable	R/W	When this enable is set high, the bus number field in the bus reset CFR at 34h clears to 3FFh when a local 1394 bus reset is received.		
16–17	BDIV0, BDIV1	BCLK divisor encode bits	R/W	BCLK divisor encode bits. Used to divide down the BCLK to generate the link power status (LPS) clock to the Phy.		
				<b>BDIV0</b>	<b>BDIV1</b>	<b>DESCRIPTION</b>
				0	0	Divide by 16. Default power-on value. Recommended for BCLK frequencies in the range of 8–60 MHz
				0	1	Divide by 2. Recommended for BCLK frequencies in the range of 1–11 MHz
				1	0	Divide by 4. Recommended for BCLK frequencies in the range of 2–22 MHz
18	DMACKCOMP	Data-mover acknowledge complete	R/W	Data-mover acknowledge complete. This bit controls the acknowledge response to an asynchronous packet received and routed to the DM port. The default and power-on value is 0, which causes the device to respond with an ack pending. A value of 1 causes the device to respond with an ack complete for write request packets.		
19	FIFOACKCOMP	FIFO acknowledge complete	R/W	FIFO acknowledge complete. This bit controls the acknowledge response to an asynchronous packet received and routed to the GRF. The default and power-on value is 0, which causes the device to respond with an ack pending. A value of 1 causes the device to respond with an ack complete.		
20	CYMAS	Cycle master	R/W	When CYMAS is set and the TSB12LV32 is attached to the root Phy, the cyclemaster function is enabled. When the cycle_count field of the cycle timer register increments, the 1394 transmitter sends a cycle-start packet. When CYMAS is cleared, the TSB12LV32 cannot be cyclemaster.		
21	CYSRC	Cycle source	R/W	When CYSRC is set, the cycle_count field increments and the cycle_offset field resets for each positive transition of CYCLEIN. When CYSRC is cleared, the cycle_count field increments when the cycle_offset field rolls over.		
22	CYTEN	Cycle timer enable	R/W	When CYTEN is set, the cycle_offset field increments.		
23	CLSIDER	Self-ID error-code clear	W	When CLSIDER is set, the SIDERCODE field (bits 24–27) is cleared. This bit clears itself.		
24–27	SID ERROR CODE	Self-ID error code	R	SID ERROR CODE contains the error code of the first self-ID error. The error code is as follows:		
				0000	No error	
				0001	Last self-ID received was not all child ports	
				0010	Received Phy ID in self-ID not as expected	
				0011	Quadlet not inverted (phase error)	
				0100	Phy ID sequence error (two or more gaps in IDs)	
				0101	Phy ID sequence error (large gap in IDs)	
				0110	Phy ID error within packet	
				0111	Quadlet not the inverse of the prior quadlet	
1000	Reserved					
28	CMAUTO	Auto set cycle master	R/W	When CMAUTO is high, the TSB12LV32 automatically enables CYMAS if this node becomes the root following a bus reset.		
29	IRP1EN	IR port 1 enable	R/W	When IRP1EN is set, the 1394 receiver accepts isochronous packets when the channel number matches the value in the IR port1 field at 18h.		
30	IRP2EN	IR port 2 enable	R/W	When IRP2EN is set, the 1394 receiver accepts isochronous packets when the channel number matches the value in the IR Port2 field at 18h.		
31	RESERVED			Reserved		

## 2.2.4 Interrupt/Interrupt Mask Registers at 0Ch and 10h

0	1	2	3	4	5	6	7	8	9	10	11	12	13	14	15	16	17	18	19	20	21	22	23	24	25	26	27	28	29	30	31	
INT	PHINT	PHRRX	PHRST	SELFIDEND	ATSTARTED	RXGRFPKT	CMDRST	DMERROR	RXDMPKT	SELFIDER	LINKON	ATSTK	ATFEMPTY	SNTRJ	HDRERR	TCERR	DMACKERR	FIFOACK	MCERROR	CYSEC	CYST	CYDNE			CYLIST	CARBFL	ARBGP	SUBGP				IARBFL

The interrupt and interrupt mask register work in tandem to inform the microcontroller interface when the state of the TSB12LV32 changes. The interrupt register is at 0Ch and the interrupt mask register is at 10h. The interrupt register powers up all 0s, however, the interrupt mask register powers up with the INT and the MCERROR bits set, i.e., 8000 1000h. The mask bits allows individual control for each interrupt. A 1 in the mask bit field allows the corresponding interrupt in the interrupt register to be generated. Once an interrupt is generated it must be cleared by writing a 1 to the bit in the interrupt register. For testing, each interrupt bit can be set manually. This is done by first setting the REGRW bit in the diagnostic register at 20h and then setting the individual interrupt bit. This is also true for bit 0 in the interrupt register. In this test mode, the interrupt mask register is not used and has no effect.

BIT NUMBER	BIT NAME	FUNCTION	DIR	DESCRIPTION
0	INT	Interrupt	R/W	INT contains the value of all interrupt and interrupt mask bits ORed together.
1	PHINT	Phy chip interrupt	R/W	When PHINT is set, the Phy has signalled an interrupt through the Phy interface
2	PHRRX	Phy register information received	R/W	When PHRRX is set, a register value has been transferred to the Phy access register (CFR at offset 24h) from the Phy interface.
3	PHRST	Phy reset started	R/W	When PHRST is set, a Phy-LLC reconfiguration has started (1394 bus reset).
4	SELFIDEND	Self-ID validated	R/W	Self-ID end. This bit is set at the end of the self-ID reporting process. When this bit is set, the contents of the bus reset CFR at 34h are valid. The RXSID bit must be set to 1 for the SELFIDEND interrupt to function.
5	ATSTARTED	Asynchronous transfer started	R/W	Asynchronous transfer started. This bit is activated when the 1394 bus has been granted and the first quadlet from the FIFO is about to be transmitted from the ATF.
6	RXGRFPKT	GRF packet received	R/W	Receive packet to GRF. This bit is set whenever a complete packet has been confirmed into the GRF (asynchronous or isochronous).
7	CMDRST	CSR register reset request	R/W	If the CMDRST bit is set, the device has been sent a quadlet write request to the Reset_Start CSR register (target address is FFFF F000 000Ch).
8	DMERROR	Data-mover error	R/W	DM error. This bit is set if there is an error in the DM stream. For transmit, if the DM port is configured for byte access and the speed code in the DM control register or the asynchronous header register is set for 400 Mbps, then this bit is set. Under this condition DMEN (bit 24 of the DM control CFR at 04h) is reset to 0, preventing further transmit. For receive this bit is set if there is a header or data CRC error or if the DM port is configured for byte access and the data is received at 400 Mbps. Any packet with a CRC error is discarded.
9	RXDMPKT	Data-mover packet receive	R/W	Receive packet to DM. This bit is set whenever a packet is received to the DM port.
10	SELFIDER	Self-ID packet error	R/W	This bit is set if an error in the self-ID quadlet/packet has been detected.
11	LINKON	Link-ON detect	R/W	This bit is set if a link-on pulse is detected on the LINKON input terminal. This bit should be used by software to reactivate the LPS output to the Phy.
12	ATSTK	Transmitter is stuck (AT)	R/W	When ATSTK is set, the transmitter has detected invalid data at the asynchronous transmit-FIFO interface. If the first quadlet of a packet is not written to the ATF_First or ATF_First&Update or there is an underflow of the ATF, an ATSTK interrupt is generated. When this state is entered, no asynchronous packets can be sent until the ATF is cleared by way of the ATFCLR control bit in the FIFO status CFR at 30h. Isochronous packets can be sent while in this state.
13	ATFEMPTY	ATF empty interrupt	R/W	ATFEMPTY. This bit is set to 1 when the ATF becomes empty.

BIT NUMBER	BIT NAME	FUNCTION	DIR	DESCRIPTION
14	SNTRJ	Busy acknowledge sent by receiver	R/W	When SNTRJ is set, the receiver is forced to send a busy acknowledge to any packet addressed to this node because the GRF overflowed.
15	HDRERR	Header error	R/W	When HDRERR is set, the receiver detected a header CRC error on an incoming packet that may have been addressed to this node. Any packet with a CRC error is discarded.
16	TCERR	Transaction code error	R/W	When TCERR is set, the transmitter detected an invalid transaction code in the data at the transmit-FIFO interface.
17	DMACKERR	Data-mover acknowledge error	R/W	DM acknowledge error. This bit is set to 1 when the acknowledge received is not <i>ack complete</i> . When this occurs, DMEN (bit 26) of the DM control CFR at 04h is reset to 0 and no more asynchronous transmissions from the DM port are allowed to take place until DMEN is set to 1.
18	FIFOACK	FIFO acknowledge interrupt	R/W	FIFO ack interrupt. This bit is set when an acknowledge from a previous ATF transmission has been received.
19	MCERROR	Microcontroller interface error	R/W	Microcontroller interface error. This bit is set whenever the microcontroller write protocol is violated. This bit is set to 1 when read or write errors occur on the microcontroller interface. This bit latches the value on the TEA signal terminal. This interrupt is set one clock cycle after the triggering error occurs.
20	CYSEC	Cycle second incremented	R/W	When CYSEC is set, the cycle-second field in the cycle timer register has incremented. This occurs about every second when the cycle timer is enabled.
21	CYST	Cycle started	R/W	When CYST is set, the transmitter has sent or the receiver has received a cycle-start packet.
22	CYDNE	Cycle done	R/W	When CYDNE is set, a subaction gap has been detected on the bus after the transmission or reception of a cycle-start packet. This bit indicates that the isochronous cycle is complete.
23	RESERVED			Reserved
24	CYLST	Cycle lost	R/W	When CYLST is set, the cycle timer has rolled over twice without the reception of a cycle-start packet. This occurs only when this node is not the cycle master. All isochronous traffic stops once CYLST is set. However, asynchronous and asynchronous stream packet traffic is not affected.
25	CARBFL	Cycle arbitration failed	R/W	When CARBFL is set, the arbitration to send a cycle-start packet has failed.
26	ARBGP	Arbitration gap	R/W	When ARBGP is set, the 1394 bus has been idle for an arbitration reset gap.
27	SUBGP	Subaction gap	R/W	When SUBGP is set, the 1394 bus has been idle for a subaction gap time (fair gap). This bit can be set only when the REGRW bit has been set in the diagnostics CFR at 20h.
28–30	RESERVED			Reserved
31	IARBFL	Isochronous arbitration failed	R/W	When IARFL is set, the arbitration to send an isochronous packet has failed.

### 2.2.5 Cycle Timer Register at 14h

0	1	2	3	4	5	6	7	8	9	10	11	12	13	14	15	16	17	18	19	20	21	22	23	24	25	26	27	28	29	30	31
SECONDS COUNT						CYCLE COUNT										CYCLE OFFSET															

This register must be written to as a quadlet. The power-up reset value of this register equals 0000 0000h.

BIT NUMBER	BIT NAME	FUNCTION	DIR	DESCRIPTION
0–6	SECONDS COUNT	Seconds count	R/W	1-Hz cycle timer counter
7–19	CYCLE COUNT	Cycle count	R/W	8,000-Hz cycle timer counter
20–31	CYCLE OFFSET	Cycle offset	R/W	24.576-MHz cycle timer counter

## 2.2.6 Isochronous Port Register at 18h

0	1	2	3	4	5	6	7	8	9	10	11	12	13	14	15	16	17	18	19	20	21	22	23	24	25	26	27	28	29	30	31
TAG1		IRPORT1						TAG2		IRPORT2						RESERVED						ISYNCRVCN			IRCVALL	RESERVED		MONTAG			

The power-up reset value of this register equals 0000 0000h.

BIT NUMBER	BIT NAME	FUNCTION	DIR	DESCRIPTION
0-1	TAG1	Tag field 1	R/W	The TAG1 field can further qualify the isochronous reception for isochronous receive PORT1 when the MONTAG bit is set.
2-7	IRPORT1	Isochronous receive port 1 channel number	R/W	IRPORT1 contains the channel number of the isochronous packets that the receiver accepts. The receiver accepts isochronous packets with this channel number when the IRP1EN bit is set.
8-9	TAG2	Tag field 2	R/W	The TAG2 field can further qualify the isochronous reception for isochronous receive PORT2 when the MONTAG bit is set.
10-15	IRPORT2	Isochronous receive port 2 channel number	R/W	IRPORT2 contains the channel number of the isochronous packets that the receiver accepts. The receiver accepts isochronous packets with this channel number when the IRP2EN bit is set.
16-23	RESERVED			Reserved
24-27	ISYNCRVCN	Synchronous enable	R/W	In isochronous receive mode to the DM port, when the ISYNCRVCN enable bits are high, the DMPRE terminal pulses when an isochronous packet is received whose SYNC bit field in its header matches the bit pattern in this field. The default is 0000b.
28	IRCVALL	Receive all isochronous packets	R/W	When the IRCVALL bit is set high, the TSB12LV32 receives all isochronous packets regardless of the channel number or tag number. The default for this bit is 0.
29-30	RESERVED			Reserved
31	MONTAG	Match on tag	R/W	MONTAG is set when the user wants to accept only isochronous packets that match both the tag field and the channel number field. When set, MONTAG indicates that isochronous receive data is accepted. The default for this bit is 0.

## 2.2.7 Maint\_Control Register at 1Ch

0	1	2	3	4	5	6	7	8	9	10	11	12	13	14	15	16	17	18	19	20	21	22	23	24	25	26	27	28	29	30	31	
E_HCRC	E_DCRC	NO_PKT	F_ACK	NO_ACK																												
																ACK								PING VALUE								

This register is used to generate test conditions. The control bits in this register allow errors to be inserted into various places in the packets generated by this node. After the completion of error insertion, enabled error-insertion controls are disabled. The power-up reset value of this register equals 0000 0000h.

BIT NUMBER	BIT NAME	FUNCTION	DIR	DESCRIPTION
0	E_HCRC	Header CRC error	R/W	If E_HCRC is set, the packet header CRC component of the next primary packet generated by this node is in error or is invalid; otherwise, this bit has no effect. After the next packet for this node is generated, this bit is cleared.
1	E_DCRC	Data CRC error	R/W	If E_DCRC is set, the packet data CRC component of the next primary packet generated by this node is in error or is be invalid; otherwise, this bit has no effect. After the next packet for this node is generated, this bit is cleared to zero immediately upon transmission of the erroneous CRC.
2	NO_PKT	No packet	R/W	If NO_PKT is set, the next primary packet to be generated by this node is discarded. This bit is cleared to zero immediately after the next packet for this node is discarded.
3	F_ACK	Ack field	R/W	If F_ACK is set, the ack field is used within the next acknowledge packet generated by this node. This bit is cleared to zero immediately after the next acknowledge packet for this node is generated.
4	NO_ACK	No ack	R/W	If NO_ACK is set, the next acknowledge packet (that would normally have been generated by this node) is not sent. This bit is cleared to zero immediately when the next acknowledge packet for this node is discarded.
5–7	RESERVED			Reserved
8–15	ACK	Ack packet field	R/W	The 8-bit ACK field contains the 8-bit acknowledge packet (ack_code and ack_parity) to be supplied when the F_ACK bit indicates a modified acknowledge packet is to be generated.
16–23	RESERVED			Reserved
24–31	PING VALUE	Ping timer value	R/W	Ping timer value. This value reflects the time it takes a node to respond to a ping packet. The granularity of this timer is 40 ns.

## 2.2.8 Diagnostic Register at 20h

0	1	2	3	4	5	6	7	8	9	10	11	12	13	14	15	16	17	18	19	20	21	22	23	24	25	26	27	28	29	30	31
B0_BUSY	B1_BUSY	B2_BUSY	B3_BUSY	B0_PND	B1_PND	B2_PND	B3_PND	RAMTEST	REGRW							STATESEL0			STATESEL1			STATESEL2									

The power-up reset value of this register equals 0000 4AD0h.

BIT NUMBER	BIT NAME	FUNCTION	DIR	DESCRIPTION
0	B0_BUSY	Byte 0 busy	R	Byte 0 busy. When this bit is set, no microcontroller write to byte 0 of any CFRs is allowed. The microcontroller must first poll this bit before writing to byte 0.
1	B1_BUSY	Byte 1 busy	R	Byte 1 busy. When this bit is set, no microcontroller write to byte 1 of any CFRs is allowed. The microcontroller must first poll this bit before writing to byte 1.
2	B2_BUSY	Byte 2 busy	R	Byte 2 busy. When this bit is set, no microcontroller write to byte 2 of any CFRs is allowed. The microcontroller must first poll this bit before writing to byte 2.
3	B3_BUSY	Byte 3 busy	R	Byte 3 busy. When this bit is set, no microcontroller write to byte 3 of any CFRs is allowed. The microcontroller must first poll this bit before writing to byte 3.
4	B0_PND	Byte 0 pending	R	Byte 0 pending. When this bit is set, it indicates that byte 0 of a word or quadlet write has been accepted and the hardware is waiting for the remaining bytes to be written. When the full write is complete, this bit is cleared.
5	B1_PND	Byte 1 pending	R	Byte 1 pending. When this bit is set, it indicates that byte 1 of a word or quadlet write has been accepted and the hardware is waiting for the remaining bytes to be written. When the full write is complete, this bit is cleared.
6	B2_PND	Byte 2 pending	R	Byte 2 pending. When this bit is set, it indicates that byte 2 of a word or quadlet write has been accepted and the hardware is waiting for the remaining bytes to be written. When the full write is complete, this bit is cleared.
7	B3_PND	Byte 3 pending	R	Byte 3 pending. When this bit is set, it indicates that byte 3 of a word or quadlet write has been accepted and the hardware is waiting for the remaining bytes to be written. When the full write is complete this bit is cleared.
8	RAM_TEST	Internal test	R/W	This bit can be set only when TESTMODE is high. When this bit is set, the built-in self-test (BIST) for the FIFOs (transmit and receive) is run. On completion of the test hardware resets this bit to 0 and simultaneously sets bits 30 and 31. This is for TI internal test purposes only.
9	REGRW	Register read/write access	R/W	When REGRW is set, write-protected bits in various registers can be written (particularly in the interrupt / interrupt mask registers).
10–15	RESERVED			Reserved
16–19	STATSEL0	State0 select	R/W	Status output select bits. Used to program the output of STAT0 terminal. See Table 1–2.
20–23	STATSEL1	State1 select	R/W	Status output select bits. Used to program the output of STAT1 terminal. See Table 1–2.
24–27	STATSEL2	State2 select	R/W	Status output select bits. Used to program the output of STAT2 terminal. See Table 1–2.
28–31	RESERVED			Reserved

## 2.2.9 Phy Access Register at 24h

0	1	2	3	4	5	6	7	8	9	10	11	12	13	14	15	16	17	18	19	20	21	22	23	24	25	26	27	28	29	30	31
RDPHY	WRPHY			PHYRGAD				PHYRGDATA												PHYRXAD				PHYRXDATA							

The Phy access register allows access to the registers in the attached 1394 Phy. The most-significant 16 bits send read and write requests to the Phy registers. The least-significant 16 bits are for the Phy to respond to a read request sent by the TSB12LV32. The Phy access register also allows the Phy interface to send information back to the TSB12LV32. When the Phy interface sends new information to the TSB12LV32, the Phy register-information-receive (PhyRRx) interrupt is set. The power-up reset value of this register equals 0000 0000h. This register, like the cycle timer register, must be accessed as a quadlet. However, the most significant word can be accessed as a doublet, because the least significant word is unwriteable except in test mode. This register is not byte accessible.

BIT NUMBER	BIT NAME	FUNCTION	DIR	DESCRIPTION
0	RDPHY	Read Phy register	R/W	When RDPHY is set, the TSB12LV32 sends a read register request with the address equal to the PHYRGAD field to the Phy interface. This bit is cleared when the request is sent.
1	WRPHY	Write Phy register	R/W	When WRPHY is set, the TSB12LV32 sends a write register request with the address equal to the PHYRGAD field to the Phy interface. This bit is cleared when the request is sent.
2–3	RESERVED			Reserved
4–7	PHYRGAD	Phy-register transmitted address	R/W	PHYRGAD is the address of the Phy register that is to be accessed.
8–15	PHYRGDATA	Phy-register transmitted data	R/W	PHYRGDATA is the data to be written to the Phy register indicated in PHYRGAD.
16–19	RESERVED			Reserved
20–23	PHYRXAD	Phy-register received address	R/W	PHYRXAD is the address of the register from which PHYRXDATA came. For testing, these bits can be set only when the REGRW bit has been set in the diagnostics CFR at 20h.
24–31	PHYRXDATA	Phy-register received data	R/W	PHYRXDATA contains the data from the register addressed by PHYRXAD. For testing, these bits can be set only when the REGRW bit has been set in the diagnostics CFR at 20h.

## 2.2.10 Reserved Registers at 28h–2Ch

These registers are reserved for future use.



## 2.2.11 FIFO Status Register at 30h

0	1	2	3	4	5	6	7	8	9	10	11	12	13	14	15	16	17	18	19	20	21	22	23	24	25	26	27	28	29	30	31
ATFCLR	ATFWBMTY	ATFAVAIL										ATFFULL	GRFCLR	GRFEMPTY	CD	ATAACK				GRFUSED											

The power-up reset value of this register equals 6083 0000h.

BIT NUMBER	BIT NAME	FUNCTION	DIR	DESCRIPTION
0	ATFCLR	ATF clear	R/W	ATF clear. When this bit is set to 1, the ATF is cleared. This bit clears itself.
1	ATFWBMTY	ATF write buffer empty	R	ATF write buffer empty. This bit is set when the 4-quadlet ATF write buffer is empty.
2–11	ATFAVAIL	ATF space available	R	Size of ATF available, in quadlets. The power-on value of this field is 10 0000 1000 (520 quadlets).
12	ATFFULL	ATF full bit	R	When the ATF is full, this bit is set.
13	GRFCLR	GRF clear bit	R/W	GRF clear. Set this bit to 1 to clear the contents of the GRF. This bit clears itself.
14	RESERVED			Reserved
15	GRFEMPTY	GRF empty	R	GRF empty. GRFEMPTY is set when the four-quadlet GRF read buffer is empty and the GRF is empty too.
16	CD	Check 33 <sup>rd</sup> bit (GRF read)	R	This bit is set to 1 when the quadlet pointed to by the GRF read pointer is the first quadlet or the packet trailer (packet token).
17–21	ATAACK	ATF acknowledge	R	The acknowledge received in response to a packet sent via the ATF
22–31	GRFUSED	GRF space used	R	GRF space used, in quadlets. This value is the number of quadlets written in the GRF. This does not count the entire read buffer, which can hold five quadlets. If the GRF is empty and the microcontroller attempts to read the GRF, the last quadlet in the GRF is reread.

### 2.2.12 Bus Reset Register at 34h

0	1	2	3	4	5	6	7	8	9	10	11	12	13	14	15	16	17	18	19	20	21	22	23	24	25	26	27	28	29	30	31
NRIDVAL	NODECNT							ROOT CONTENDER		IRMNODEID						BUS NUMBER						NODE NUMBER									

The power-up reset value of this register equals 81BF FFC0h.

**NOTE:** The power-up reset value shown above assumes one node on the bus only. A 1394a-2000 compliant Phy is assumed to be attached to the TSB12LV32. If a 1394-1995 Phy is attached to the TSB12LV32 link, the NODECNT field is 0. This is due to the fact that a 1394-1995 compliant Phy does not report its self-ID packet back to the local link.

BIT NUMBER	BIT NAME	FUNCTION	DIR	DESCRIPTION
0	NRIDVAL	Valid	R	When set, NRIDVAL indicates that the node ID, IRM node ID, node count, and root information are valid. This bit is read-only.
1	RESERVED			Reserved
2–7	NODECNT	Node count	R	NODECNT contains the number of nodes detected in the system. This field is loaded with 1 following a power-on reset. The NODECNT field is read-only.
8	ROOT	Root	R	Root is set when the current node is the root node. This bit is read-only.
9	CONTENDER	Contender	R	Contender contains the status of the TSB12LV32 CONTNDR terminal. This bit is read-only.
10–15	IRMNODEID	IRM node identification	R	IRMNODEID is the isochronous resource manager node identification. If there is no IRM node present on the bus, these bits are equal to 3Fh. These bits are read-only.
16–25	BUS NUMBER	Bus number	R/W	BUSNUMBER is the 10-bit IEEE 1212 bus number. These bits are set to 3FFh when the BUSNRST bit in the control CFR at 08h is set and there is a bus reset.
26–31	NODE NUMBER	Node number	R/W	NODENUMBER is the node number of the current node. These bits are automatically updated following a bus reset. To change the node number of this node (spoofing), the TESTMODE terminal must be set high. Spoofing is used for TI internal test purposes only.

### 2.2.13 Header0 Register at 38h

Header0 register contains the isochronous packet header or the first quadlet of an asynchronous packet header if the device is in automatic-header-insert transmit mode. If the device is not in automatic-header-insert transmit mode or if it is in receive mode, this register is updated with the received header or the DM-supplied transmit header. This register is write protected such that it cannot be written to unless automatic header insert mode is enabled and the DM is in transmit mode (i.e., DMHDR = 0 and DMRX = 0). The power-up reset value of this register equals 0000 0000h.

#### ISOCRONOUS HEADER FOR QUADLET 0

0	1	2	3	4	5	6	7	8	9	10	11	12	13	14	15	16	17	18	19	20	21	22	23	24	25	26	27	28	29	30	31
PACKET DATA LENGTH																TAG		CHANNEL NUMBER				TCODE			SYNC BITS						

BIT NUMBER	BIT NAME	FUNCTION	DIR	DESCRIPTION
0–15	PACKET DATA LENGTH	Packet data length	R/W	Packet data length in bytes.
16–17	TAG	Tag field	R/W	The tag field provides a high-level label for the format of the data carried by the isochronous packet.
18–23	CHANNEL NUMBER	Channel number	R/W	Channel number field
24–27	TCODE	Transmission code	R/W	Packet transaction code
28–31	SYNC BITS	Synchronization code	R/W	An application-specific control field

## ASYNCHRONOUS HEADER FOR QUADLET 0

0	1	2	3	4	5	6	7	8	9	10	11	12	13	14	15	16	17	18	19	20	21	22	23	24	25	26	27	28	29	30	31
														SPEED		TLABEL				RT		TCODE			PRIORITY						

BIT NUMBER	BIT NAME	FUNCTION	DIR	DESCRIPTION
0–13	RESERVED			Reserved
14–15	SPEED	Speed	R/W	Speed at which the Phy is to transmit the packet: 00 => S100 01 => S200 10 => S400
16–21	TLABEL	Transaction label	R/W	Transaction label
22–23	RT	Retry code	R/W	The retry code specifies whether this packet is a retry attempt and the retry protocol to be followed by the destination node.
24–27	TCODE	Transaction code	R/W	The transaction code specifies the packet format and the type of transaction that is to be performed.
28–31	PRIORITY	Priority field	R/W	Priority code (applies only to the backplane Phy)

## 2.2.14 Header1 Register at 3Ch

Header1 register contains the isochronous packet header (if multiple channels are supported) or the second quadlet of an asynchronous packet header if the device is in automatic header insert transmit mode. If the device is not in automatic-header-insert transmit mode or if it is in receive mode, this register is updated with the second received header quadlet or the DM-supplied transmit header. This register powers up with all bits reset to 0. For multiple isochronous channels (multiple isochronous packets within the same isochronous cycle), this register contains the isochronous header of the second isochronous packet in the same format as the header0 register if the device is in automatic-header-insert transmit mode. This register is write protected such that it cannot be written to unless automatic-header-insert mode is enabled and the DM is in transmit mode (i.e., DMHDR = 0 and DMRX = 0).

## ISOCRONOUS HEADER FOR QUADLET 1

0	1	2	3	4	5	6	7	8	9	10	11	12	13	14	15	16	17	18	19	20	21	22	23	24	25	26	27	28	29	30	31
PACKET DATA LENGTH																TAG		CHANNEL NUMBER				TCODE			SYNC BITS						

BIT NUMBER	BIT NAME	FUNCTION	DIR	DESCRIPTION
0–15	PACKET DATA LENGTH	Packet data length	R/W	Packet data length in bytes
16–17	TAG	Tag field	R/W	The tag field provides a high-level label for the format of the data carried by the isochronous packet.
18–23	CHANNEL NUMBER	Channel number	R/W	Channel number field
24–27	TCODE	Transmission code	R/W	Packet transaction code
28–31	SYNC BITS	Synchronization code	R/W	An application-specific control field

## ASYNCHRONOUS HEADER FOR QUADLET 1

0	1	2	3	4	5	6	7	8	9	10	11	12	13	14	15	16	17	18	19	20	21	22	23	24	25	26	27	28	29	30	31
DESTINATION ID																															

BIT NUMBER	BIT NAME	FUNCTION	DIR	DESCRIPTION
0–15	DESTINATION ID	Destination ID	R/W	For asynchronous packets this field contains the destination node ID.
16–31	RESERVED			Reserved

### 2.2.15 Header2 Register at 40h

Header2 register contains the isochronous packet header (if multiple channels are supported) or the third quadlet of an asynchronous packet header if the device is in automatic-header-insert transmit mode. If the device is not in automatic-header-insert transmit mode or if it is in receive mode, this register is updated with the third quadlet of the asynchronous received header or the DM-supplied transmit header. This register powers up with all bits reset to 0. For multiple isochronous channels (multiple isochronous packets within the same isochronous cycle), this register contains the isochronous header of the third isochronous packet in the same format as the header0 register if the device is in automatic-header-insert transmit mode. This register is write protected such that it cannot be written to unless automatic-header-insert mode is enabled and the DM is in transmit mode (i.e., DMHDR = 0 and DMRX = 0).

#### ISOCRONOUS HEADER FOR QUADLET 2

0	1	2	3	4	5	6	7	8	9	10	11	12	13	14	15	16	17	18	19	20	21	22	23	24	25	26	27	28	29	30	31
PACKET DATA LENGTH																TAG		CHANNEL NUMBER				TCODE			SYNC BITS						

BIT NUMBER	BIT NAME	FUNCTION	DIR	DESCRIPTION
0–15	PACKET DATA LENGTH	Packet data length	R/W	Packet data length in bytes
16–17	TAG	Tag field	R/W	The tag field provides a high-level label for the format of the data carried by the isochronous packet.
18–23	CHANNEL NUMBER	Channel number	R/W	Channel number field
24–27	TCODE	Transmission code	R/W	Packet transaction code
28–31	SYNC BITS	Synchronization code	R/W	An application-specific control field

#### ASYNCHRONOUS HEADER FOR QUADLET 2

0	1	2	3	4	5	6	7	8	9	10	11	12	13	14	15	16	17	18	19	20	21	22	23	24	25	26	27	28	29	30	31
HEADER2																															

BIT NUMBER	BIT NAME	DIR	DESCRIPTION
0–31	HEADER2	R/W	Third header quadlet for an asynchronous packet or header for a multiple isochronous packet

## 2.2.16 Header3 Register at 44h

Header3 register contains the isochronous packet header (if multiple channels are supported) or the fourth quadlet of an asynchronous packet header if the device is in automatic-header-insert transmit mode. If the device is not in automatic-header-insert mode or if it is in receive mode, this register is updated with the fourth quadlet of the asynchronous received header or DM-supplied transmit header. This register powers up with all bits reset to 0. For multiple isochronous channels (multiple isochronous packets within the same isochronous cycle), this register would contain the isochronous header of the fourth isochronous packet in the same format as the header0 register if the device is in automatic-header-insert transmit mode. This register is write protected such that it cannot be written to unless automatic-header-insert mode is enabled and the DM is in transmit mode (i.e., DMHDR = 0 and DMRX = 0).

### ISOCRONOUS HEADER FOR QUADLET 3

0	1	2	3	4	5	6	7	8	9	10	11	12	13	14	15	16	17	18	19	20	21	22	23	24	25	26	27	28	29	30	31
PACKET DATA LENGTH																TAG		CHANNEL NUMBER				TCODE			SYNC BITS						

BIT NUMBER	BIT NAME	FUNCTION	DIR	DESCRIPTION
0–15	PACKET DATA LENGTH	Packet data length	R/W	Packet data length in bytes
16–17	TAG	Tag field	R/W	The tag field provides a high-level label for the format of the data carried by the isochronous packet.
18–23	CHANNEL NUMBER	Channel number	R/W	Channel number field
24–27	TCODE	Transmission code	R/W	Packet transaction code
28–31	SYNC BITS	Synchronization code	R/W	An application-specific control field

### ASYNCHRONOUS HEADER FOR QUADLET 3

0	1	2	3	4	5	6	7	8	9	10	11	12	13	14	15	16	17	18	19	20	21	22	23	24	25	26	27	28	29	30	31
HEADER3																															

BIT NUMBER	BIT NAME	DIR	DESCRIPTION
0–31	Header3	R/W	Fourth header quadlet for an asynchronous packet or header for a multiple isochronous packet

## 2.2.17 Trailer Register at 48h

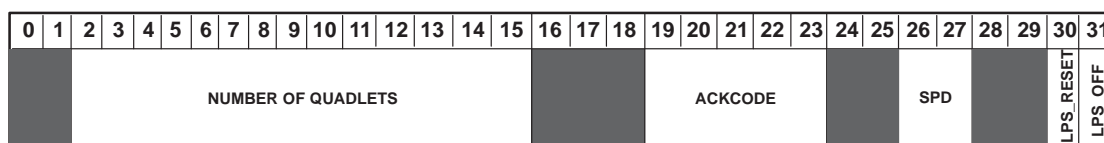

The power-up reset value of this register equals 0000 0000h.

BIT NUMBER	BIT NAME	FUNCTION	DIR	DESCRIPTION	
0–1	RESERVED			Reserved	
2–15	NUMBER OF QUADLETS	Number of quadlets	R/W	Total number of quadlets in the current packet (data payload and header quadlets only)	
16–18	RESERVED			Reserved	
19–23	ACKCODE	Acknowledge code	R/W	This 5-bit field holds the acknowledge code sent by the receiver for the current packet (see Note following the table):	
				<b>ACKCODE</b>	<b>Name</b>
				00000	Reserved
				00001	Ack_complete
				00010	Ack_pending
				00011	Reserved
				00100	Ack_busy_X
				00101	Ack_busy_A
				00110	Ack_busy_B
				00111–01010	Reserved
				01011	Ack_tardy
				01100	Ack_conflict_error
				01101	Ack_data_error
				01110	Ack_type_error
01111	Ack_address_error				
10000	No ack received	These codes are added by the link layer and are not part of the IEEE 1394–1995 specification.			
10001	Ack too long (more than 8 bits)				
10010	Ack too short (less than 8 bits)				
10011–11111	Reserved				
24–25	RESERVED			Reserved	
26–27	SPD	Speed code	R/W	The SPD field indicates the speed at which the current packet was sent. 00 ≥ 100 Mbps, 10 ≥ 400 Mbps, 01 ≥ 200 Mbps, 11 is undefined.	
28 – 29	RESERVED			Reserved	
30	LPS_RESET	LPS reset	R/W	Link power status reset. This bit is set by software and is reset by hardware. When this bit is set, hardware deactivates LPS for a fixed period to ensure that the Phy has reset the interface. It then reactivates LPS. When this bit is cleared by hardware, a PHRST interrupt in the interrupt CFR at 0Ch is also generated.	
31	LPS_OFF	LPS off	R/W	Link power status off. If set to 1, this bit turns off the LPS-pulsed output to the Phy. This bit can also be turned off from the Phy. Upon detection of the LINKON pulsed input signal, this bit is turned off, allowing LPS to be driven to the Phy which, in turn, activates SCLK and powers up the link.	

**NOTE:** The acknowledge code specified by the IEEE 1394-1995 specification is a 4-bit field. The ACKCODE field in this register is a 5-bit field. The TSB12LV32 logic core is able to provide (specify) three additional ACKCODEs, which are not part of the original specification. The ACKCODEs are 10000, 10001, and 10010.

## 2.2.18 Asynchronous Retry Register at 4Ch

0	1	2	3	4	5	6	7	8	9	10	11	12	13	14	15	16	17	18	19	20	21	22	23	24	25	26	27	28	29	30	31
ASYNC RETRY COUNT								RETRY INTERVAL																							

The TSB12LV32 only supports single-phase retry protocol and does not implement dual-phase retry protocol. See Section 7.3.5 of the IEEE Std 1394-1995 (IEEE standard for a high-performance serial bus) for more information on retry protocol. The power-up reset value of this register equals 0000 0000h.

BIT NUMBER	BIT NAME	FUNCTION	DIR	DESCRIPTION
0-7	ASYNC RETRY COUNT	Retry count	R/W	The asynchronous retry count field specifies the number of times to automatically retry sending asynchronous packets from the ATF before giving up. After the retry count is exhausted the FIFOACK interrupt in the interrupt CFR at 0Ch is generated when an ACK_BUSY_X is received.
8-15	RETRY INTERVAL	Retry interval	R/W	Asynchronous retry interval is the time in increments of isochronous cycles between asynchronous retries.
16-31	RESERVED			Reserved

### 3 Microcontroller Interface

The microcontroller interface allows the local microcontroller/microprocessor to communicate with the internal control and configuration registers (CFR), asynchronous transfer FIFO (ATF) and general receive FIFO (GRF). All microcontroller reads/writes are initiated by the microcontroller. The microcontroller interface supports read transactions from the CFR or GRF, and write transactions to the CFR or ATF.

The microcontroller interface can operate in byte (8 bit) or word (16 bit) accesses. Each CFR, with the exception of the cycle timer register at 14h and the Phy access register at 24h, can be addressed on byte or word boundaries. The possible configurations for the interface are shown in Table 3–1. The TSB12LV32 can also be directly connected to the Motorola 68000 and ColdFire™ line of MC/MP. Table 3–2 defines the mapping of the microcontroller interface pins between the TSB12LV32, the Motorola 68000 and the ColdFire microprocessor.

**Table 3–1. Microcontroller Interface Modes of Operation**

TSB12LV32 MODE-CONFIGURATION TERMINALS			MODE OF OPERATION
COLDFIRE	M8BIT_SIZ0	MCMODE_SIZ1	
0	0	0	16-bit fixed timing mode
0	0	1	16-bit $\overline{\text{MCS}}$ - $\overline{\text{MCA}}$ handshake mode
0	1	0	8-bit fixed timing mode
0	1	1	8-bit $\overline{\text{MCS}}$ - $\overline{\text{MCA}}$ handshake mode
1	0	0	ColdFire 4-byte (2-word) burst mode
1	0	1	ColdFire 2-byte (1-word) mode
1	1	0	ColdFire 1-byte mode (not supported)
1	1	1	ColdFire 16-byte (8-word) burst mode

**Table 3–2. TSB12LV32 MP/MC Interface Terminal Function Matrix**

TSB12LV32		MOTOROLA 68000/ColdFire MICROCONTROLLER	
TERMINAL NAME	USAGE	TERMINAL NAME	USAGE
MA0–MA6	Input	A[6:0]	Output
MD0–MD15	I/O	D[31:16]	I/O
$\overline{\text{MCA}}$	Output	TAZ	Input
$\overline{\text{MCS}}$	Input	TSZ	Output
$\overline{\text{MWR}}$	Input	R/WZ	Output
MCMODE/SIZ1, M8BIT/SIZ0	Input	SIZ1, SIZ0	Output
$\overline{\text{TEA}}$	Output	TEAZ	Input
BCLK	Input	SCLK / CLK	Input

The byte stacker allows the TSB12LV32 to be easily connected to most processors. The byte stacker consists of a programmable 8-/16-bit data bus and a 7-bit address bus. The TSB12LV32 uses cycle-start and cycle-acknowledge handshake signals to allow the local bus clock and the 1394 clock to be asynchronous to one another. The TSB12LV32 has an interrupt driver to reduce cycling. All bus signal labeling on the TSB12LV32 microcontroller interface uses bit 0 to denote the most significant bit (MSB).

The transfer error acknowledge ( $\overline{\text{TEA}}$ ) is asserted whenever there is an illegal transfer request by the microcontroller, such as:



- The requested data transfer size is unsupported.
  - An ATF burst access ends on a nonquadlet boundary.
  - A microcontroller address is not on a word boundary while in 16-bit data-bus mode.
  - The microcontroller attempts to write to the CFR across quadlet boundaries.
  - A GRF read-byte address does not start from 00h.
  - GRF read is not done on a quadlet boundary.
- ColdFire error
  - $\overline{MCS}$  is asserted for more than one BCLK cycle for each transaction.

### 3.1 Microcontroller Byte Stack (Write) Operation

The microcontroller byte stack (write) protocol is shown in Figure 3–1.

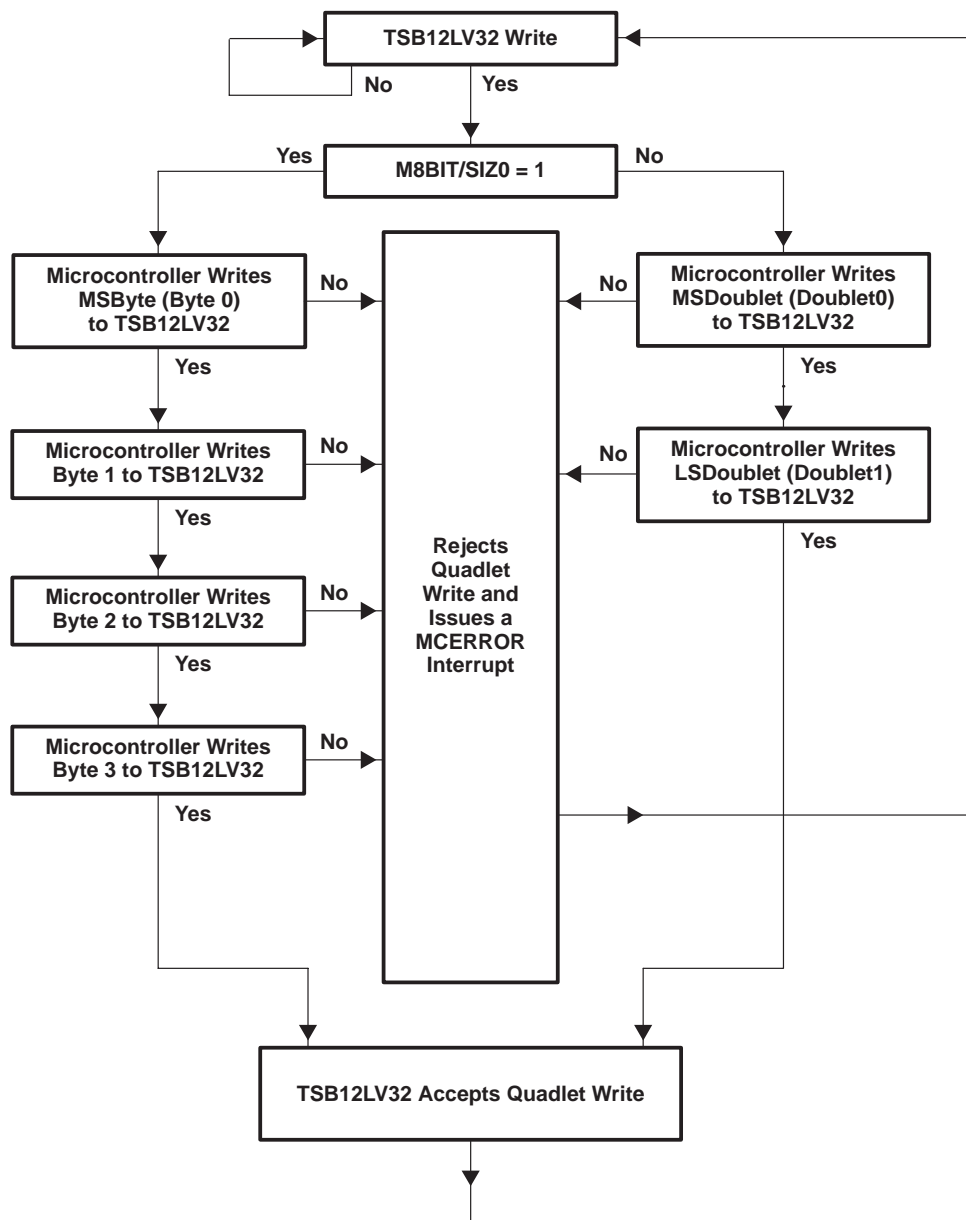

Figure 3–1. Microcontroller Byte Stack (Write) Operation

### 3.2 Microcontroller Byte Unstack (Read) Operation

The microcontroller byte unstack (read) protocol is shown in Figure 3–2.

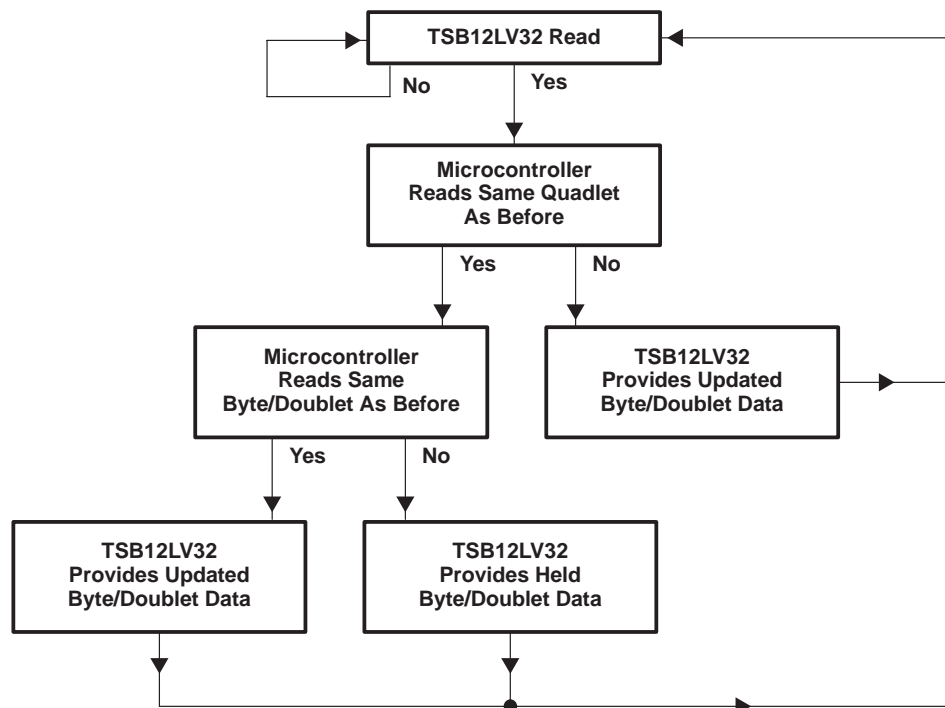

Figure 3–2. Microcontroller Byte Unstack (Read) Operation

### 3.3 Microcontroller Interface Read/Write Timing

The microcontroller interface can be configured to operate in one of the following modes: handshake, fixed-timing, or ColdFire mode. Burst transfers are only supported in the latter two modes.

#### 3.3.1 Microcontroller Handshake Mode

Byte handshake read and word handshake read are shown in Figure 3–3 and Figure 3–4, respectively.

The signal timing sequence for a handshake read transaction can be summarized as follows:

1. The host takes  $\overline{MCS}$  low to signal the start of access. When the rising edge of BCLK samples  $\overline{MCS}$  low and  $\overline{MWR}$  high, the MD[0:15] lines are enabled and driven with the read value. For an 8-bit data bus, the MD[0:7] lines are not used.
2. Following the next rising edge of BCLK, the TSB12LV32 takes  $\overline{MCA}$  low to signal that the requested operation is complete. This takes place after two BCLK cycles.  $\overline{MCA}$  remains low with the MD lines containing valid read data until the microcontroller interface releases  $\overline{MCS}$  (high state)
3. The host takes  $\overline{MCS}$  high to signal the end of the process.
4. The TSB12LV32 holds  $\overline{MCA}$  low until  $\overline{MCS}$  is sampled high, then  $\overline{MCA}$  is set high to acknowledge the end of the access. The MD lines are not put in the high-impedance state until after  $\overline{MCA}$  is taken high.

After  $\overline{MCA}$  is asserted high, another read or write transaction can begin after the next rising edge of BCLK. Note that data size is determined by the M8BIT/SIZ0 signal, it is asserted high to select byte mode in Figure 3–3 and asserted low to select word mode in Figure 3–4. The MCMODE/SIZ1 signal determines if the microcontroller is operating in handshake mode or fixed timing mode; it is asserted high to select handshake mode. The COLDFIRE signal is only asserted high when the microcontroller interface is operating in ColdFire mode.

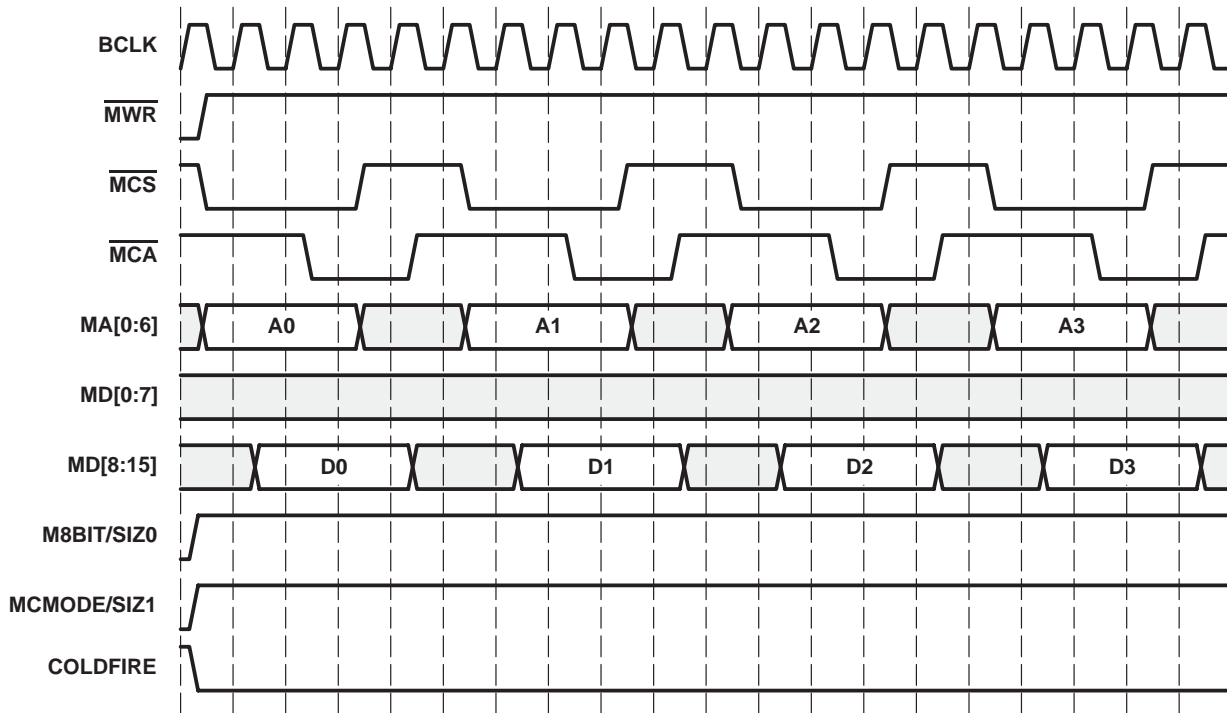

Figure 3–3. Byte Handshake Read

Figure 3–4 shows a word handshake read transaction. In this case, all 16 bits of the MD lines are used. Note that MD[0] contains the MSB and MD[15] contains the LSB. As in the byte read case, after MCA is asserted high another read or write transaction can begin after the next rising edge of BCLK.

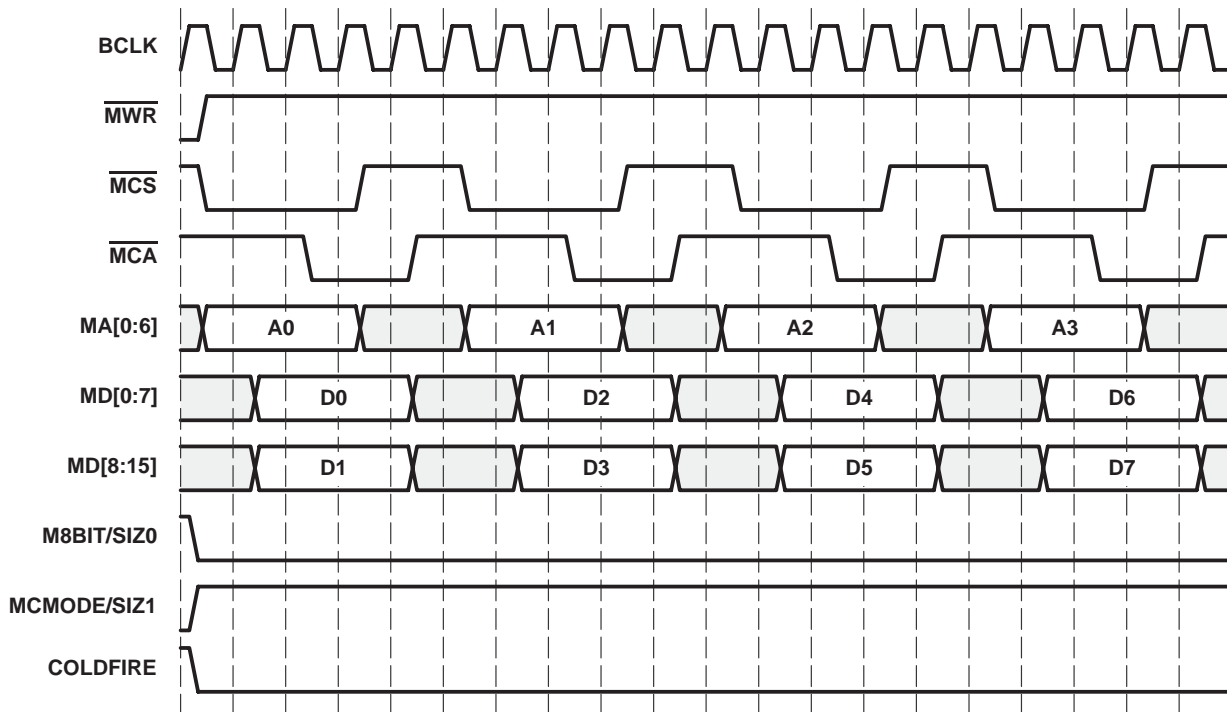

Figure 3–4. Word Handshake Read

Byte handshake write and word handshake write are shown in Figure 3–5 and Figure 3–6. In this case, the microcontroller interface asserts  $\overline{MCA}$  low immediately after  $\overline{MCS}$  is sampled low. The data on the MD bus is valid when  $\overline{MCS}$  and  $\overline{MWR}$  are both low. The microcontroller interface keeps  $\overline{MCA}$  low until it samples  $\overline{MCS}$  high. For 8-bit accesses, the MD[0:7] lines are not used. If a transfer error condition occurs,  $\overline{TEA}$  is asserted low for one BCLK cycle. An error condition can occur if the MCMODE/SIZ1 or M8BIT/SIZ0 line changes state during the access cycle.

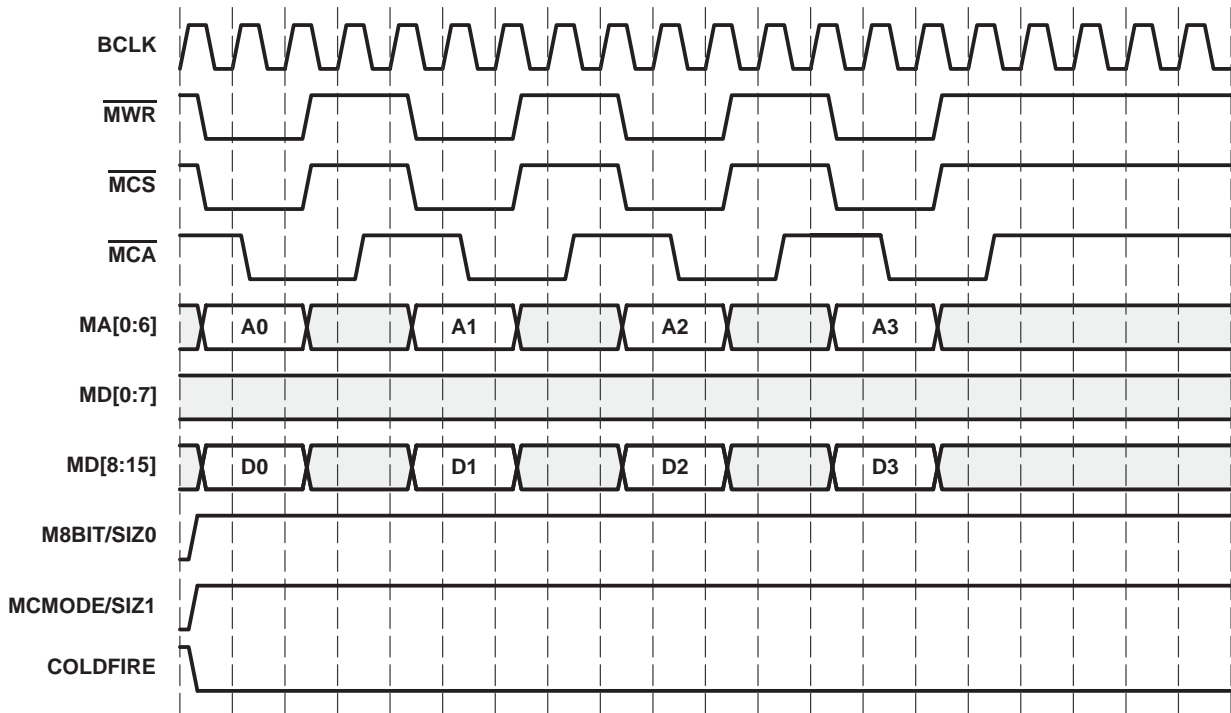

Figure 3–5. Byte Handshake Write

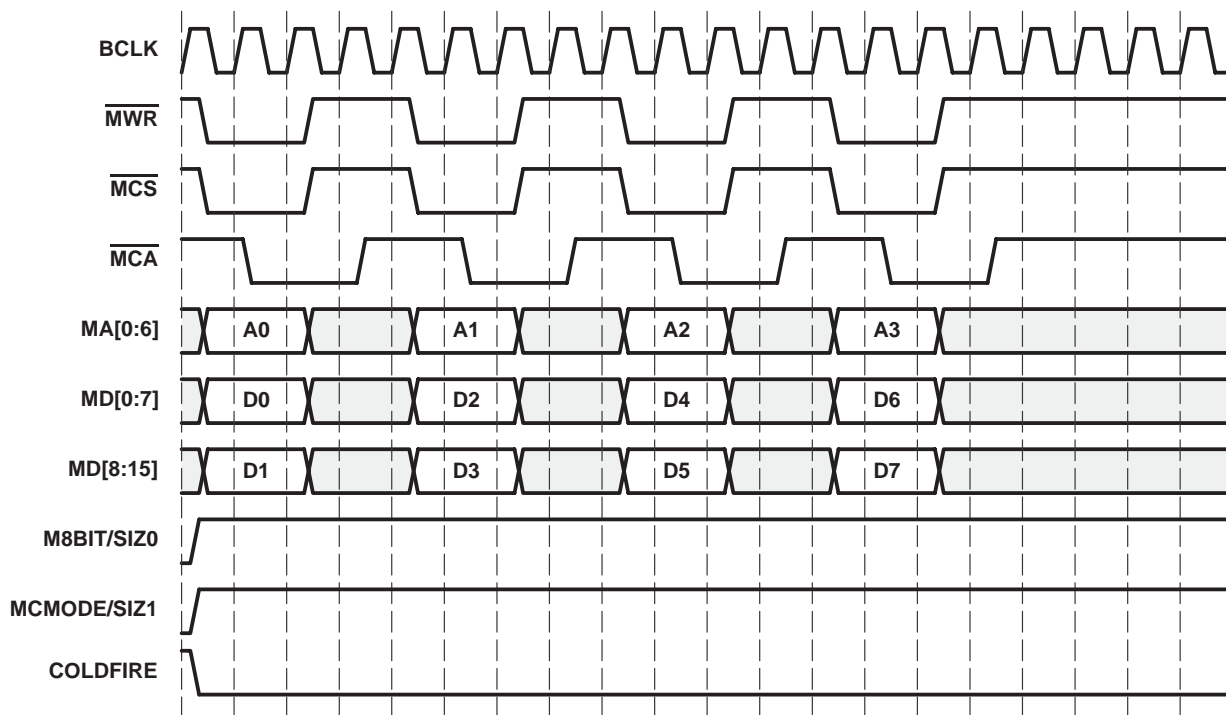

Figure 3–6. Word Handshake Write

### 3.3.2 Microcontroller Fixed-Timing Mode

Byte fixed-timing reads and word fixed-timing reads are shown in Figure 3–7 and Figure 3–8, respectively. In addition to single byte or single word transfers, fixed-timing mode supports burst transfers. If  $\overline{\text{MCS}}$  is asserted low for more than one BCLK cycle, burst mode is enabled. The fixed-timing burst mode does not have a limit on the maximum burst size allowed.

The signal timing sequence for a fixed-timing read transaction can be summarized as follows:

1. The microcontroller pulses  $\overline{\text{MCS}}$  low to signal the start of access. Pulsing  $\overline{\text{MCS}}$  low for more than one clock cycle enables burst mode. The number of BCLK cycles during which  $\overline{\text{MCS}}$  is asserted low determines the total burst size.
2. When the rising edge of BCLK samples  $\overline{\text{MCS}}$  low and  $\overline{\text{MWR}}$  high, the register value or GRF data pointed to by the MA bus is latched onto the MD lines. The MD lines latch on every rising edge of BCLK if  $\overline{\text{MCS}}$  continues to be asserted low. The first data transfer of each fixed-timing read (single byte/word or burst) requires one extra BCLK cycle due to propagation delay in the device. In the case of a burst data transfer, all subsequent reads require only one BCLK cycle. The data on the MD bus is valid when  $\overline{\text{MCA}}$  is low.
3. After 2 BCLK cycles, the TSB12LV32 pulses  $\overline{\text{MCA}}$  low for one clock cycle to signal the completion of the requested operation. If  $\overline{\text{MCS}}$  is pulsed low for  $n$  BCLK cycles,  $\overline{\text{MCA}}$  also is pulsed low for  $n$  cycles. Note that MA needs only contain valid data during the first cycle in which  $\overline{\text{MCS}}$  is low. Except for the first one, every data transfer takes only one BCLK cycle. If a read transaction is accessing the CFR, it may not cross any register boundary (see Section 3.3.2.1 for information on fixed-timing read access to the GRF). During a burst read or a burst write, the initial latched address on the MA bus is automatically incremented by the hardware for each additional read or write, and the value on the MA bus is ignored until the next transfer.

After  $\overline{\text{MCA}}$  is asserted high, another read or write transaction can begin after the next rising edge of BCLK. Note that data size is determined by the M8BIT/SIZ0 signal, it is asserted high to indicate a byte transfer and it is asserted low to indicate a word transfer. The MCMODE/SIZ1 signal is asserted low to select fixed timing mode.

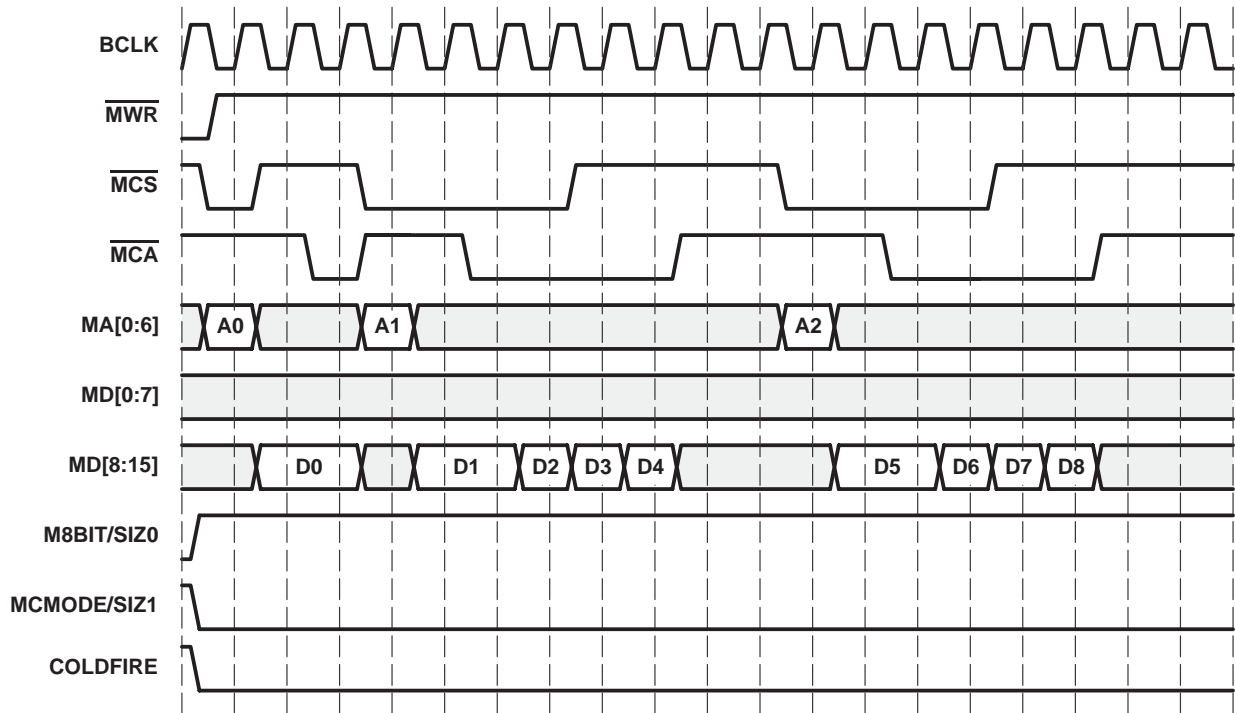

Figure 3–7. Byte Fixed-Timing Read

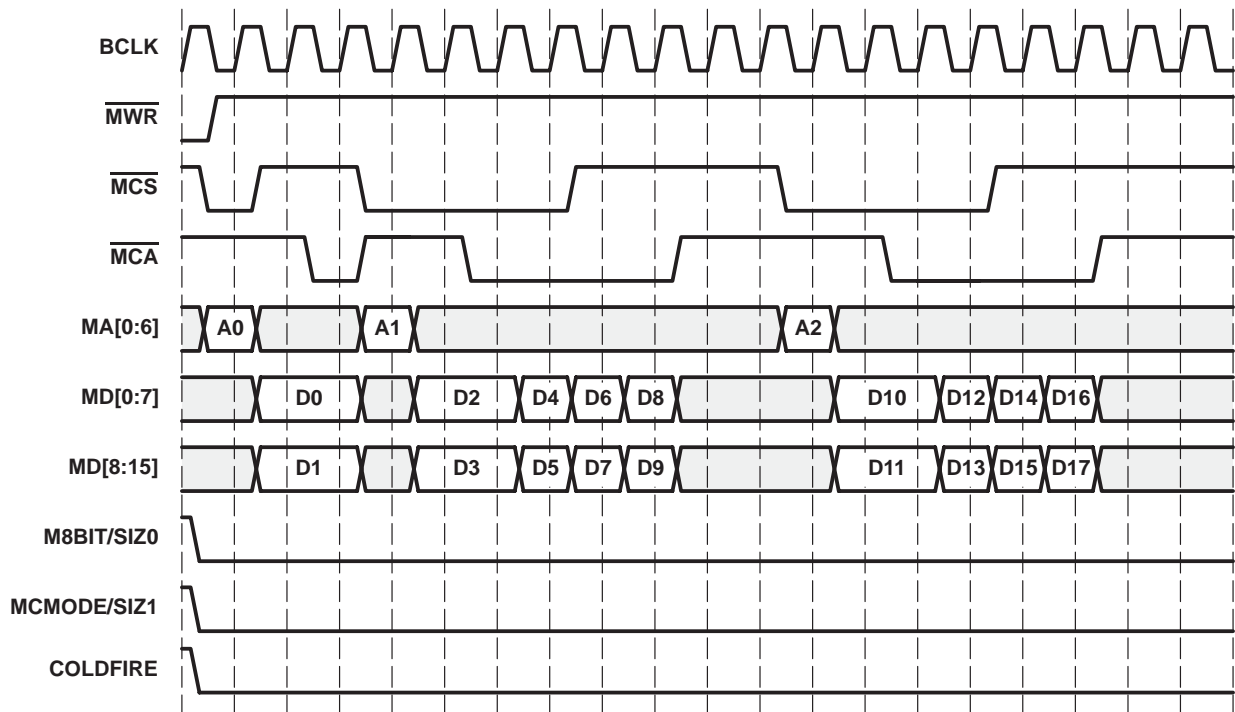

Figure 3–8. Word Fixed-Timing Read

Byte fixed-timing write and word fixed-timing write are shown in Figure 3–9 and Figure 3–10, respectively.

Unlike the fixed-timing read transfers, no extra wait cycles are required for fixed-timing write transfers. For an 8-bit data bus, MD[0:7] is not used (don't care) and is driven with zeros. If the write transaction is accessing a CFR register, it cannot cross any register boundary. The first write data for each ATF quadlet must start at byte0. Write accesses to the ATF must be quadlet aligned. The microcontroller interface waits for all bytes of each quadlet to be available before creating a write request to the ATF. If a transfer error condition occurs,  $\overline{TEA}$  is asserted low for one BCLK cycle. An error condition can occur if the MCMODE/SIZ1 or M8BIT/SIZ0 lines transition during the access cycle.

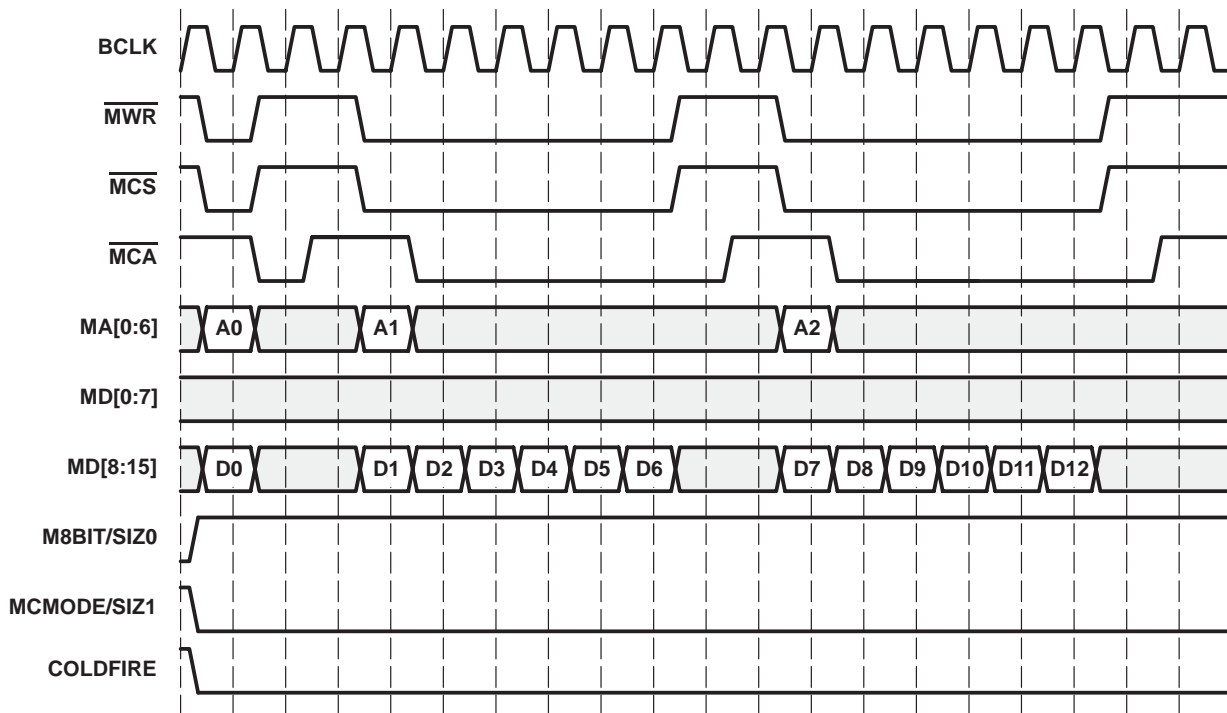

Figure 3–9. Byte Fixed-Timing Write

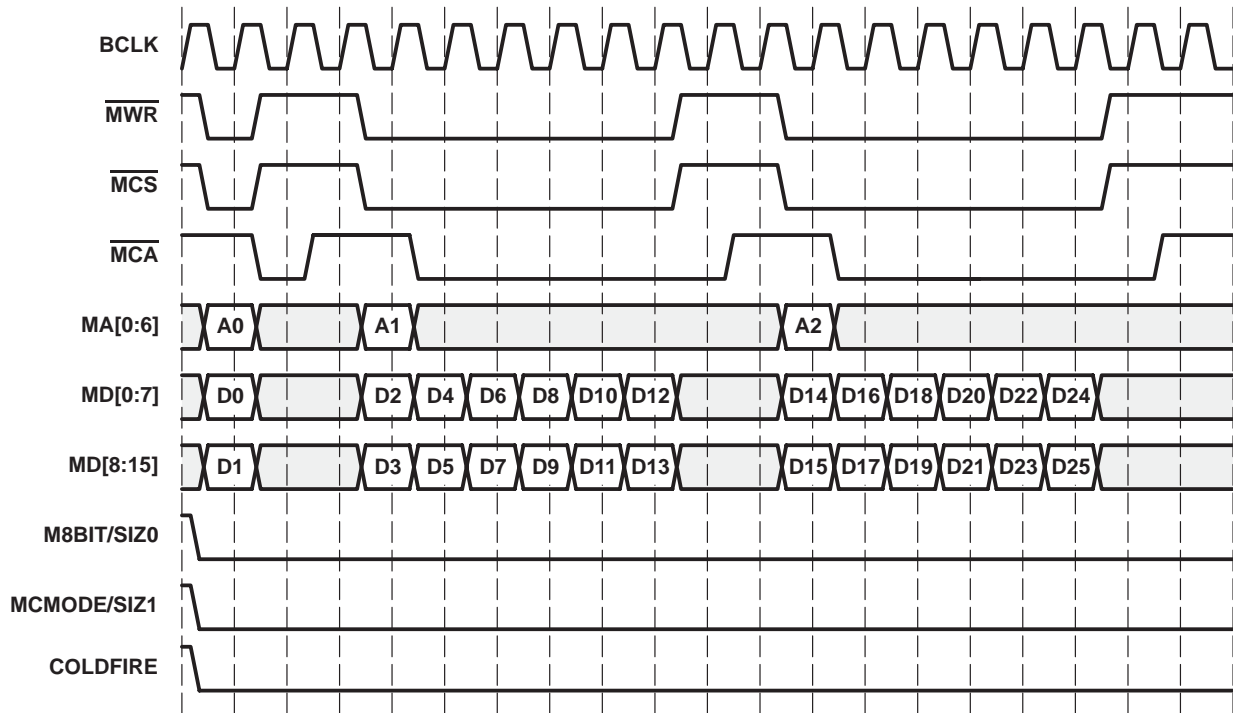

Figure 3–10. Word Fixed-Timing Write

### 3.3.2.1 GRF READ in Fixed-Timing Mode

The timing requirements when performing a GRF read access in fixed-timing mode are different from timing requirements of a CFR read access in the fixed-timing mode. In fixed-timing mode, the GRF must be accessed only on a quadlet boundary. In other words, only quadlet fetches are legal. If the microinterface is configured for a byte access, this means that  $\overline{MCS}$  must be asserted low for 4 BCLK cycles, as shown in Figure 3–11. If configured for word access, then  $\overline{MCS}$  must only be asserted for 2 BCLK cycles, as shown in Figure 3–12. After  $\overline{MCA}$  is driven high, another read or write transaction can begin after the next rising edge of BCLK.



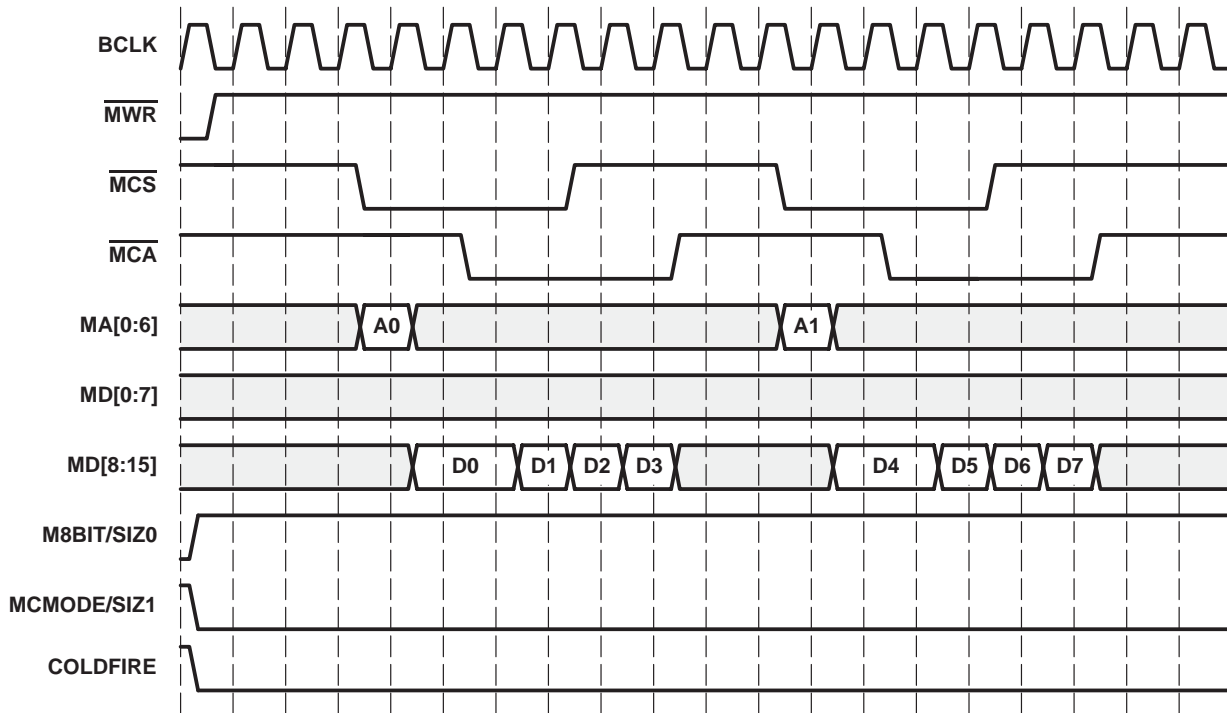

Figure 3–11. GRF Read Access (Byte Fixed-Timing Mode)

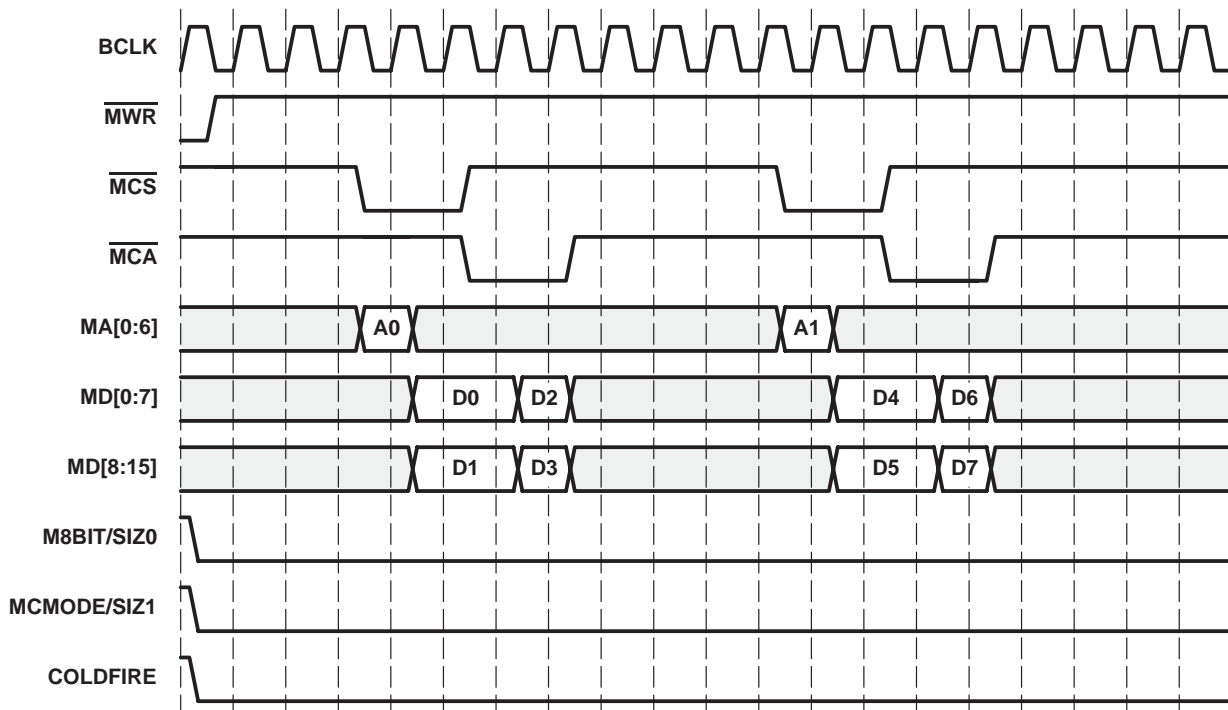

Figure 3–12. GRF Read Access (Word Fixed-Timing Mode)

### 3.3.3 Microcontroller ColdFire Mode

The TSB12LV32 supports a glueless interface to the ColdFire family of microcontrollers. To enable this mode, the COLDFIRE pin must be asserted and kept high for the entire access cycle. The timing diagram for a ColdFire read operation is shown in Figure 3–13.

The timing sequence for a ColdFire read access can be summarized as follows:

1. The ColdFire pulses  $\overline{\text{MCS}}$  low for one BCLK cycle to signal the start of access.  $\overline{\text{MCS}}$  must only be asserted for one clock cycle.
2. When the rising edge of BCLK samples  $\overline{\text{MCS}}$  low and  $\overline{\text{MWR}}$  high, MD lines are enabled, but do not yet contain valid data. The MA lines should contain the address information at this point. MA is only required to be available for one BCLK cycle. The data transfer size is determined by the state of the MCMODE/SIZ1 and M8BIT/SIZ0 lines.
3. The TSB12LV32 pulses  $\overline{\text{MCA}}$  low for n clock cycles to signal the requested operation is complete. The number n depends on the data transfer size specified by the MCMODE/SIZ1 and M8BIT/SIZ0 lines. The CFR register value or GRF memory data pointed to by the MA lines is latched onto the MD lines.  $\overline{\text{MCA}}$  pulses for one clock cycle on every word (2 byte) transfer.

The microinterface uses burst transfers if the MCMODE/SIZ1 and M8BIT/SIZ0 lines indicate more than 2 bytes (1 word) of data. The TSB12LV32 does not support 1-byte transfers in the ColdFire mode.

MCMODE/SIZ0	M8BIT/SIZ1	TRANSFER SIZE (BYTES)
0	0	4
0	1	2
1	0	1*
1	1	0

\* A transfer size of 1 byte is not valid and  $\overline{\text{TEA}}$  is asserted lo for one BCLK cycle.

If any transfer error condition occurs,  $\overline{\text{TEA}}$  is asserted low for one BCLK cycle. An error condition can occur if the MCMODE/SIZ1 and M8BIT/SIZ0 lines specify a transfer size of 1 byte or if their state changes during the access cycle. Note that all 16 bits of the MD lines are always used in the ColdFire mode.

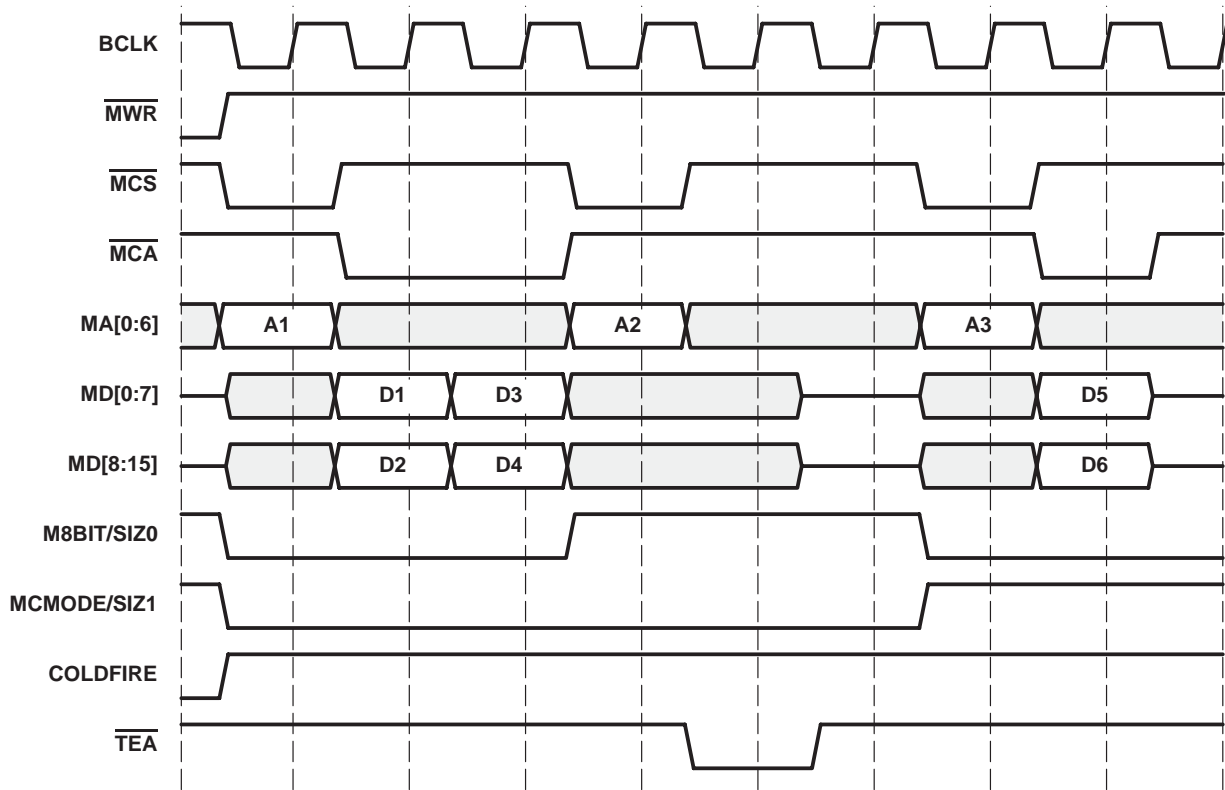

Figure 3–13. ColdFire Read

The ColdFire write transaction is shown in Figure 3–14. Unlike the handshake and fixed-timing write modes, the ColdFire write operation requires the data on the MD lines be available one BCLK cycle after the address on the MA lines is sampled. Violating this timing requirement can result in a transfer error, causing  $\overline{TEA}$  to be asserted low for one BCLK cycle.

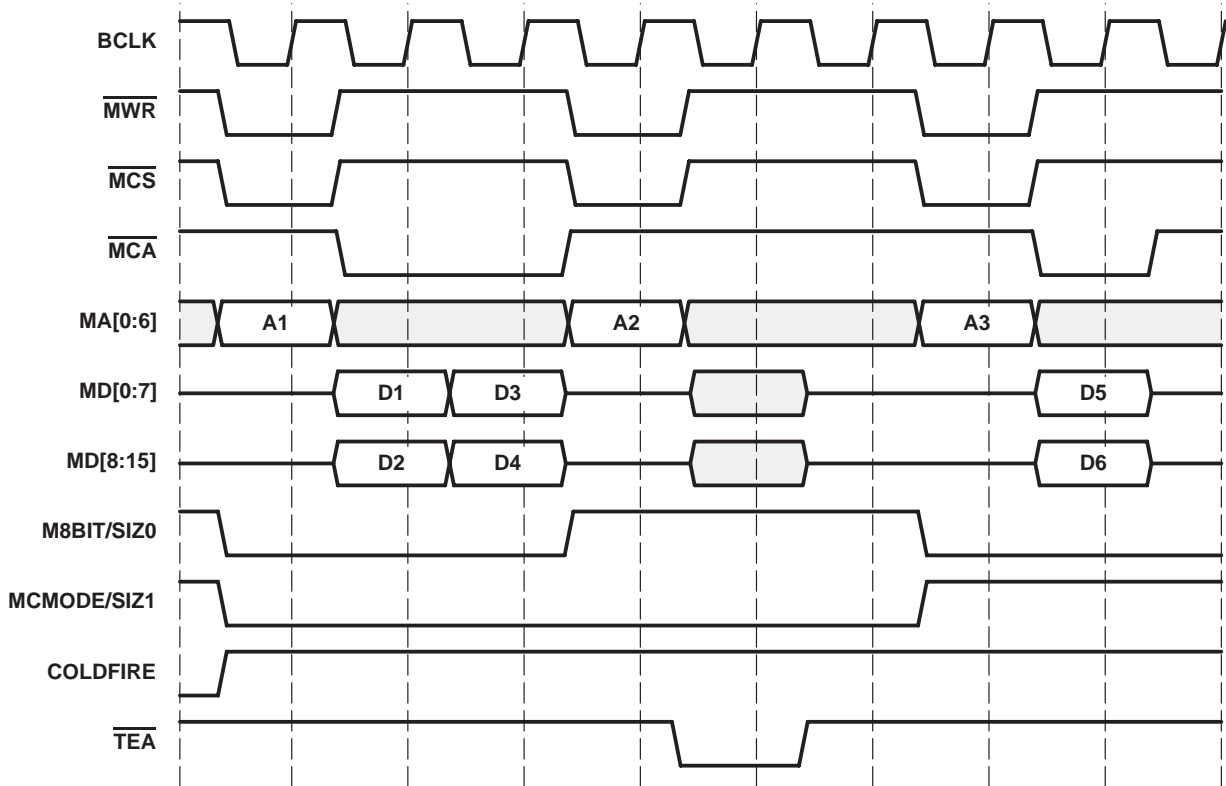

Figure 3–14. ColdFire Write

### 3.3.4 Microcontroller Critical Timing

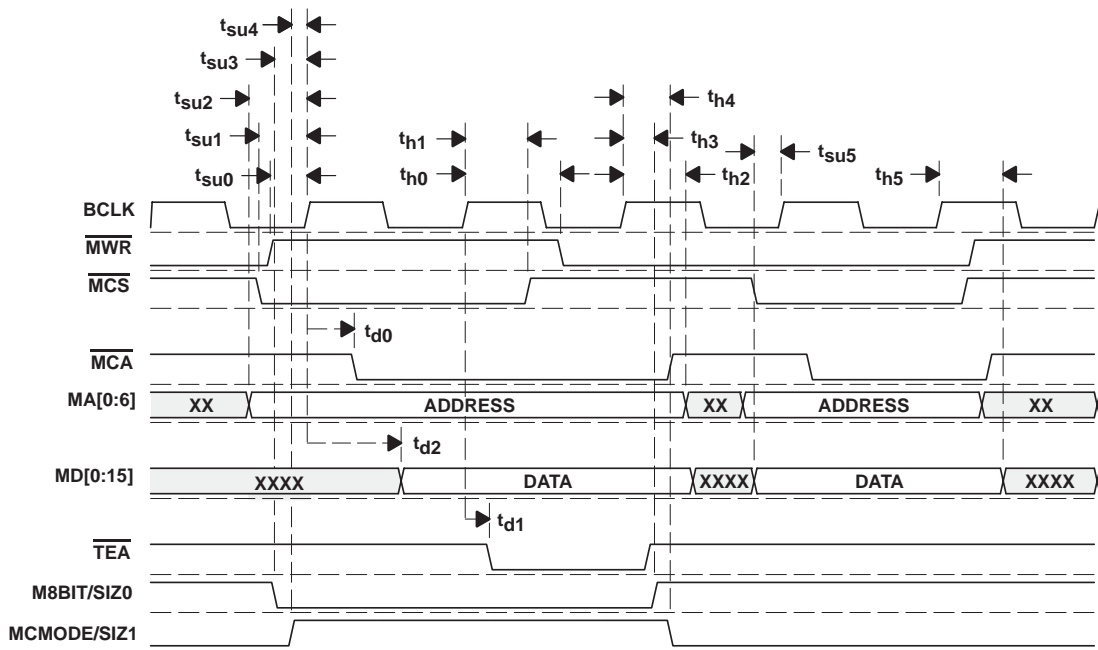

Figure 3–15. Microcontroller Timing

**Table 3–3. Microcontroller Timing**

PARAMETER†		TERMINAL NAME	ACCESS TYPE	MIN	MAX	UNIT
t <sub>d0</sub>	Delay time (BCLK to Q)	MCA	Read/Write	3.75	9.5	ns
t <sub>d1</sub>		TEA	Read/Write	3.75	9.5	
t <sub>d2</sub>		MD[0:15]	Read	2.5	10.5	
t <sub>su0</sub>	Setup time to BCLK	MWR	Read/Write	4.5		ns
t <sub>su1</sub>		MCS	Read/Write	6.5		
t <sub>su2</sub>		MA[0:6]	Read/Write	6.5		
t <sub>su3</sub>		M8BIT/SIZ0	Read/Write	5		
t <sub>su4</sub>		MCMODE/SIZ1	Read/Write	3.5		
t <sub>su5</sub>		MD[0:15]	Write	3		
t <sub>h0</sub>	Hold time from BCLK	MWR	Read/Write	1.75		ns
t <sub>h1</sub>		MCS	Read/Write	1.5		
t <sub>h2</sub>		MA[0:6]	Read/Write	2		
t <sub>h3</sub>		M8BIT/SIZ0	Read/Write	1.5		
t <sub>h4</sub>		MCMODE/SIZ1	Read/Write	1.75		
t <sub>h5</sub>		MD[0:15]	Write	1.5		

† All timing parameters are referenced to the rising edge of BCLK.

### 3.3.5 Endian Swapping

The term *endianness* refers to the way data is referenced and stored in a processor's memory. For example, consider a 32-bit processor; any 32-bit word consists of four bytes which can be stored in memory in one of two ways. Of the four bytes, either byte 3 is considered the most significant byte and byte 0 the least significant byte, or vice versa (see Figure 3–16 and Figure 3–17). A little endian type memory considers byte 0 the least significant byte, whereas a big endian type memory considers byte 3 to be the least significant byte.

Byte #0 (Most Significant Byte)	Byte #1	Byte #2	Byte #3 (Least Significant Byte)
------------------------------------	---------	---------	-------------------------------------

**Figure 3–16. Big Endian Format**

Byte #3 (Most Significant Byte)	Byte #2	Byte #1	Byte #0 (Least Significant Byte)
------------------------------------	---------	---------	-------------------------------------

**Figure 3–17. Little Endian Format**

The TSB12LV32 configuration register space (CFR) and FIFO memory, both of which are 32 bits wide, use a big endian architecture. The TSB12LV32 uses the same endianness as the internal 1394a-2000 link core. This means that the most significant byte is the left-most byte (byte 0) and the least significant byte is the right-most byte (byte 3).

#### 3.3.5.1 Data and Address Invariance for Little Endian Processors

For little-endian processors, there are two modes of byte swapping, address invariant and data invariant. Address invariance preserves byte ordering between the internal system (GP2Lynx registers and FIFO) and external system (microcontroller/processor). Data invariance preserves the bit significance of the data, but changes the byte significance between the internal and external systems. The MDINV pin controls how the write/read data is swapped at the data bus (i.e., determines how the received bytes from the microcontroller are mapped into the TSB12LV32 internal registers and memory space). Note that when the COLDFIRE pin is high, the MDINV pin has no affect and data is always interpreted as big endian. See *Endianness and the TSB12LV41 (MPEG2Lynx) Microprocessor Interface*, Texas Instruments literature number SLLA021, for a detailed description of endianness.

The pin settings for all the swapping operations are shown in Table 3–3. Note that in performing the byte swapping operation in the little-endian mode, only the two least significant bits of the 32-bit address inside are involved. This is because there is a total of four bytes associated with the swapping operation.

Table 3–4. Endian Swapping Operations

LENDIAN	M8BIT/SIZO	MDINV	DESCRIPTION
0	X	X	Big-endian mode, no manipulation on byte address and data bytes
1	1 (8-bits wide)	1	Little-endian data invariance mode, swap the low order 2 bit address: <b>External low-order 2-bit address</b> <b>Internal low order 2-bit address</b> Byte Address 00      ↔      Byte Address 11 Byte Address 01      ↔      Byte Address 10 Byte Address 00      ↔      Byte Address 11 Byte Address 11      ↔      Byte Address 00
1	01 (16-bits wide)	1	Little-endian data invariance mode, swap the low order 2 bit address: <b>External low-order 2-bit address</b> <b>Internal low order 2-bit address</b> Word Address 00      ↔      Word Address 10 Word Address 10      ↔      Word Address 00
1	1	0	16-bit little-endian address invariance mode, swap data between MD[0:7] and MD[8:15].
1	1	0	8-bit little-endian address invariance mode, no manipulation on byte address and data bytes.

Because the TSB12LV32 microprocessor interface is either 8 bits or 16 bits wide, but the internal configuration registers are 32 bits wide, a byte stacking (for writes) and a byte unstacking (for reads) operation must be performed on the data bus. For little endian processors, the TSB12LV32 can perform the swapping of bytes on the data bus required to allow both the processor and the TSB12LV32 to interpret the data the same. There are two methods of swapping the data bytes, address invariant and data invariant. Both of these methods are described in the following sections.

**NOTE:** For the host processor to work correctly with the TSB12LV32, users *must* correctly connect the address and data busses of their microprocessor to the TSB12LV32 microprocessor port. Users must connect the MSB (most significant bit) of their address/data bus to the address/data MSB of the TSB12LV32. This must be done regardless of bit number labeling or which type of endianness the microprocessor uses.

### 3.3.5.2 Data-Invariant System Design

Figure 3–18 shows a little-endian data-invariant system design example. In this system, the actual value of the data as it was stored in the processor memory is preserved. Data-invariant designs do not preserve the addresses when mapping between endian domains. If the data represents an integer, it is interpreted the same by both systems. If the data represents a string, an array, or some other type of byte indexed structure, it is interpreted differently by both systems.

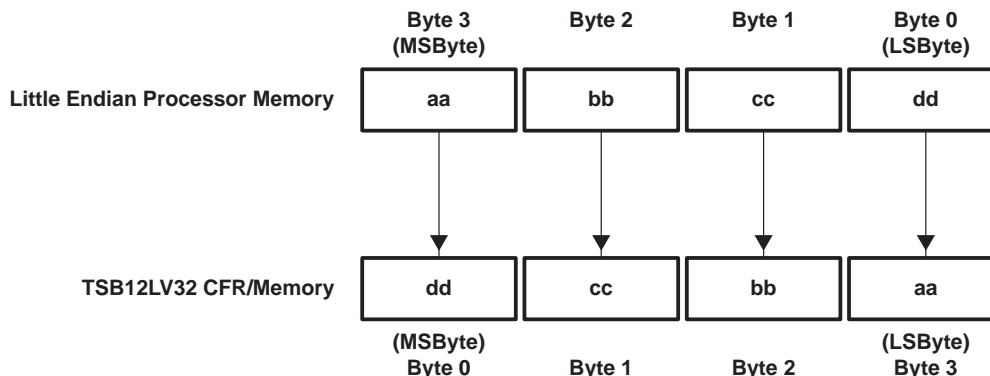

Figure 3–18. Little-Endian Data-Invariance Illustration Chart

### 3.3.5.3 Address Invariant System Design

Figure 3–19 shows a little-endian address-invariant system design example. In this case, the byte ordering between both systems is preserved (i.e., byte address is preserved). For example, byte 3 in the little-endian processor memory is also byte 3 in the TSB12LV32 CFR space. As Figure 3–19 shows, the byte ordering is automatically maintained by the TSB12LV32 when in the address-invariance mode by swapping the order in which the incoming bytes on the microprocessor are written to the CFRs.

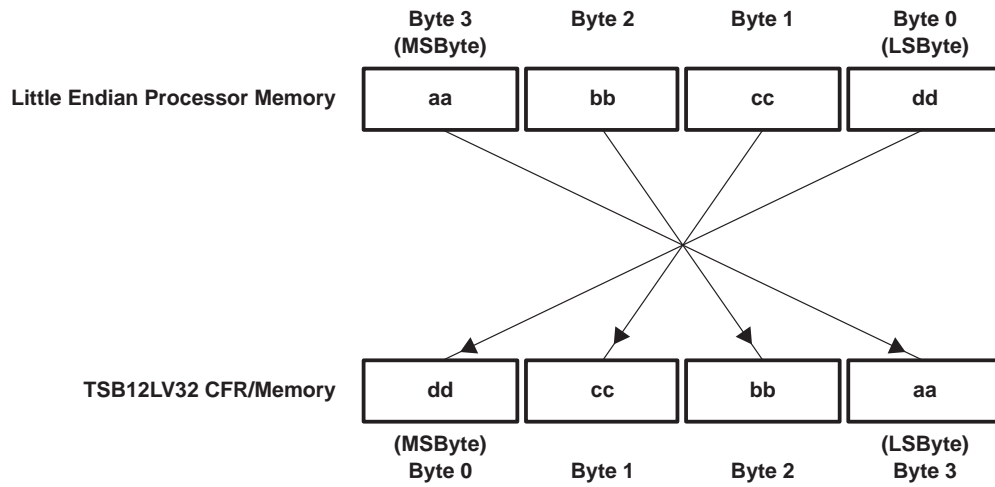

Figure 3–19. Little-Endian Address-Invariance Illustration Chart

## 4 Link Core

This section describes the link core components and operations. Figure 4–1 shows the link core components.

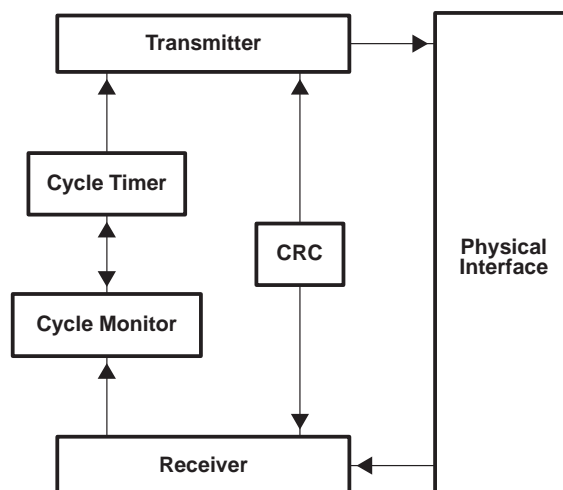

Figure 4–1. Link Core Components

### 4.1 Physical Interface

The physical (Phy) interface provides Phy-level services to the transmitter and receiver. This includes gaining access to the serial bus, sending packets, receiving packets, and sending and receiving acknowledge packets. The Phy interface module also interfaces to the Phy chip and implements Texas Instruments patent-pending bus-holder galvanic isolation.

### 4.2 Transmitter

The transmitter retrieves data from either the asynchronous transmit FIFO (ATF) or the data-mover (DM) port and creates correctly formatted 1394 packets to be transmitted through the Phy interface. When data is present at the ATF interface to the transmitter, the TSB12LV32 Phy interface arbitrates for the 1394 bus and sends an asynchronous packet. When data is present at the DM port, the TSB12LV32 requests bandwidth during the next isochronous cycle from the 1394 bus isochronous resource master if the packet is isochronous or arbitrates for the 1394 bus if the packet is asynchronous. The transmitter autonomously sends the cycle-start packets when the device is a cycle master.

### 4.3 Receiver

The receiver takes incoming data from the Phy interface and determines if the incoming data is addressed to the node. When the incoming packet is addressed to the node, the CRC of the packet is checked. If the header CRC is good, the header is confirmed in the general receive FIFO (GRF). For asynchronous stream packets and isochronous packets, the remainder of the packet is confirmed one quadlet at a time. The receiver places a status quadlet in the GRF after the last quadlet of the packet is confirmed into the GRF. The status quadlet contains the error code for the packet.

In the case of asynchronous packets, the error code is the acknowledge code that is sent (returned) for that packet. For isochronous and broadcast packets that do not need acknowledge packets, the error code is the acknowledge code that would have been sent. This acknowledge code tells the transaction layer whether or not the data CRC is good or bad. If the header CRC is bad, the header is flushed and the rest of the packet is ignored. When a cycle-start packet is received, it is detected and the cycle-start packet data is sent to the cycle timer. Cycle-start packets are not placed in the GRF like other quadlet packets.



## 4.4 Cycle Timer

The cycle timer is only used by nodes that support isochronous data transfer. The cycle timer is a 32-bit cycle-timer register. Each node with isochronous data-transfer capability has a cycle-timer register as defined by the IEEE 1394-1995 specification. In the TSB12LV32, the cycle-timer register is implemented in the cycle timer located in the IEEE 1212 initial register space at location 200h and can also be accessed through the local bus at TSB12LV32 CFR address 14h. The low-order 12 bits of the timer are a modulo 3072 counter, which increments once every 24.576-MHz clock period (or 40.69 ns). The next 13 higher-order bits are a count of 8,000 Hz (or 125  $\mu$ s) cycles, and the highest 7 bits count seconds. The cycle timer contains the cycle-timer register. The cycle-timer register consists of three fields: cycle offset, cycle count, and seconds count. The cycle timer has two possible sources. First, when the cycle source (CYSRC) bit in the configuration register (bit 21 of the control CFR at 08h) is set, then the CYCLEIN input terminal causes the cycle count field to increment for each positive transition of the CYCLEIN input (8 kHz) and the cycle offset resets to all zeros. CYCLEIN should only be the source when the node is the cycle master. The timer can also be disabled using the cycle-timer-enable bit (CYTEN) in the control register. The second cycle-source option is when the CYSRC bit is cleared. In this state, the cycle-offset field of the cycle-timer register is incremented by the internal 24.576-MHz clock. The cycle timer is updated by the reception of the cycle-start packet for the noncycle master nodes. The cycle-offset field in the cycle-start packet is used by the cycle-master node to keep all nodes in phase and running with a nominal isochronous cycle of 125  $\mu$ s. The cycle-start bit is set when the cycle-start packet is sent from the cycle master node or received by a noncycle master node.

## 4.5 Cycle Monitor

The cycle monitor is only used by nodes that support isochronous data transfer. The cycle monitor observes device activity and handles scheduling of isochronous activity. When a cycle-start message is received or sent, the cycle monitor sets the cycle-started interrupt bit. It also detects missing cycle-start packets and sets the cycle-lost interrupt bit when this occurs. When the isochronous cycle is complete, the cycle monitor sets the cycle-done-interrupt bit. The cycle monitor instructs the transmitter to send a cycle-start message when the cyclemaster bit (CYMAS) is set in the control register.

## 4.6 Cyclic Redundancy Check (CRC)

The CRC module generates a 32-bit CRC for error detection. This is done for both the header and the data. The CRC module generates the header and data CRC for transmitting packets and checks the header and data CRC for received packets (see the IEEE 1394-1995 standard for details on the generation of the CRC).

## 4.7 Received Packet Routing Control Logic

Asynchronous and isochronous receive packets can be routed to the DM port or the GRF depending on the setting of the receiver routing control logic. Bit IRCVALL in the isochronous port CFR at 18h must be set for all isochronous data to be routed according to Table 4–1. Note that self-ID packets and Phy packets are always received by the GRF regardless of the routing control settings.

Table 4–1. Receiver Routing

AR0	AR1	DMASYNC	DMRX	DATA MOVER (DM)	GENERAL-RECEIVE FIFO (GRF)
0	0	X	0	Receives no data; Power-on default	Receives all data (asynchronous and isochronous); power-on default
		X	1	Receives read response packets with a tlabel of 11XXXX	Receives all other asynchronous packets and isochronous packets
0	1	1	1	Receives asynchronous data	Receives isochronous/asynchronous stream packet
		X	0	Receives no data	Receives all data
		0	1	Receives isochronous/asynchronous stream packet	Receives asynchronous data
1	0	X	0	Receives no data	Receives all data
		0	1	Receives no data	Receives all data
		1	1	Receives addressed write-request asynchronous packets in the address range of 0000 0000 0000h to 0000 FFFF FFFFh	Receives addressed asynchronous packets in the address range of 0001 0000 0000h to FFFF FFFF FFFFh. Also receives any asynchronous packets not going to the DM port regardless of the address. Receives isochronous packets too.
1	1	X	0	Receives no data	Receives all data
		X	1	Receives all data (asynchronous and isochronous)	Receives no data



## 5 Data-Mover Port Interface

The data-mover (DM) port in the TSB12LV32 is the physical medium by which autonomous data streams of different types are piped to/from an application that uses the TSB12LV32. The DM port is meant to support an external memory interface that supplies or accepts large data packets.

The DM port can support three types of packets:

- Asynchronous
- Isochronous
- Asynchronous stream packets (1394a-2000 supported format)

The DM port can be configured to either transmit data (asynchronous packets or isochronous packets) or receive data (asynchronous and/or isochronous) at one time (half duplex). A typical system diagram is shown in Figure 5–1.

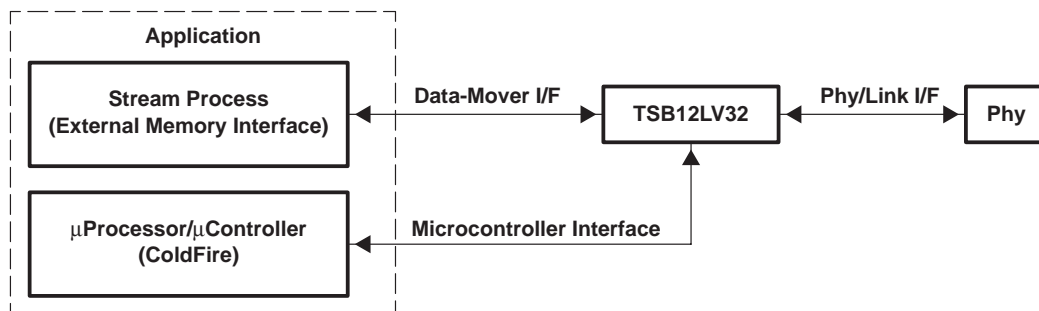

Figure 5–1. A Typical System Diagram

The DM port performs all operations synchronously, using a 24.576-MHz output clock called DMCLK. DMCLK is essentially SCLK/2. There is no asynchronous logic within the DM block. All data transfers are synchronized to the DMCLK output. The DM operates by setting the DM control CFR at 04h and the control CFR at 08h. The DM logic module interfaces internally with the configuration register (CFR) block and the link core (Link) block and interfaces externally with the data-mover external interface.

The advantages of the DM port can be summarized as follows:

- Transmits or receives large blocks of data at speeds up to 400 Mbps.
- Allows for a large external FIFO specific to an individual application.
- Handles asynchronous, isochronous, or asynchronous stream packets.
- The DM interface goes to the high-impedance-state when not in use.

The DM isochronous transmit reads data from the DM interface (DMD[0:15] lines) and passes it to the 1394 isochronous transmit interface in accordance with Figure 5–2. The data path is shown in Figure 5–3.

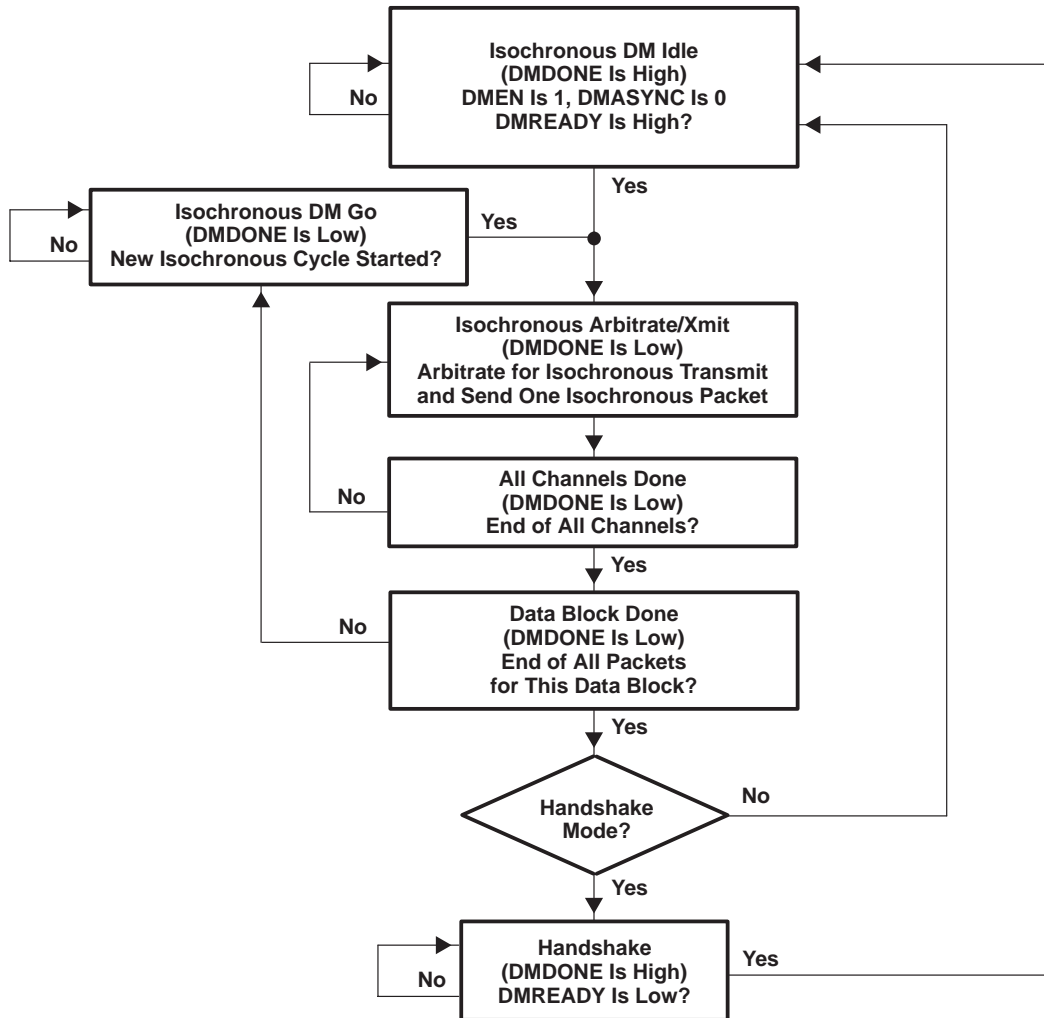

Figure 5–2. Isochronous Transmit DM Flow Control (TSB12LV32 Transmit to 1394 Bus)

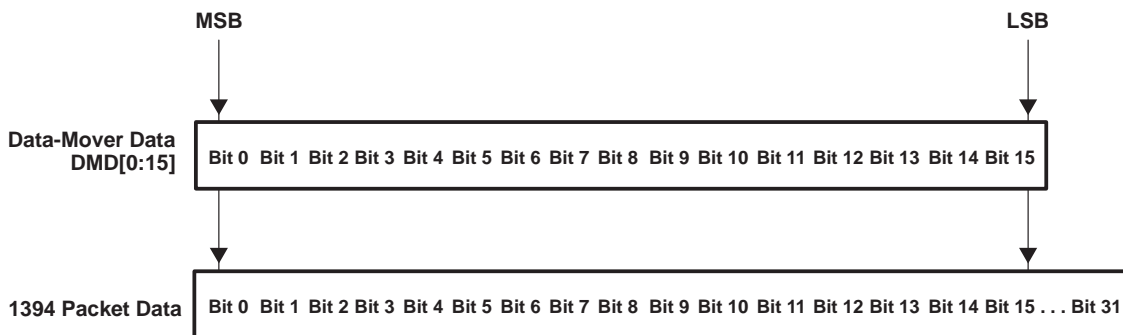

Figure 5–3. Transmit Data Path

The DM asynchronous transmit reads data from the DM interface (DMD[0:15] lines) and passes it to the 1394 asynchronous interface in accordance with Figure 5–4.

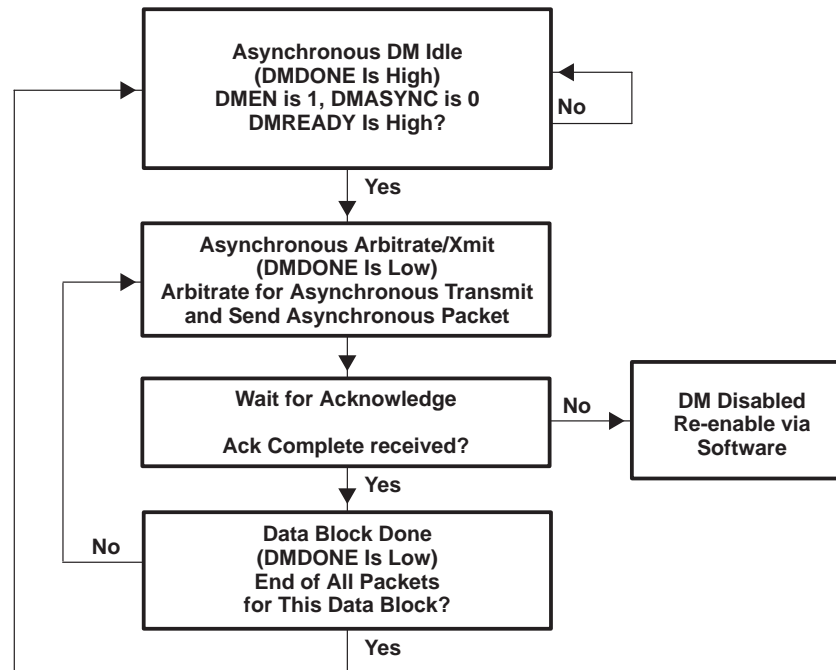

Figure 5–4. Asynchronous Transmit DM Flow Control (TSB12LV32 Transmit to 1394 Bus) (DMASYNC = 1)

## 5.1 Data-Mover Data Flow Diagram

The data mover has eight modes of operation. There are four modes for transmit and four modes for receive.

- Isochronous receive with automatic header / trailer removal
- Isochronous receive without automatic header / trailer removal
- Isochronous transmit with automatic header insertion
- Isochronous transmit without automatic header insertion
- Asynchronous receive with automatic header / trailer removal
- Asynchronous receive without automatic header / trailer removal
- Asynchronous transmit with automatic header insertion
- Asynchronous transmit without automatic header insertion

### Definitions

- Data-mover port configured to operate in transmit mode means that the packet data is received through the data-mover port and forwarded (unbuffered) to the link core transmit logic to be sent to the physical layer device (Phy), which, in turn, *transmits* the data onto the 1394 bus.
- Data-mover port configured to operate in receive mode means that the packet data is *received* by the link core receive logic from the 1394 bus through the Phy. The data is then routed by the link core to the data-mover port without any internal buffering.

### 5.1.1 Isochronous Receive

In both the isochronous receive modes, the packet header information is always loaded into the header registers in the CFR. The isochronous packet header quadlet is loaded into the header0 register at 38h and the isochronous packet trailer quadlet is loaded into the trailer register at 48h.

### 5.1.1.1 Isochronous Packet Receive With Automatic Header and Trailer Removal

- Step 1:** Isochronous packet is received through the receiver logic of the link core.
- Step 2:** The packet header is stripped off from the packet and loaded into the header0 register at 38h.
- Step 3:** Packet data (payload only) is routed directly to the DM port without any buffering.
- Step 4:** Trailer quadlet is loaded into the trailer register at 48h.

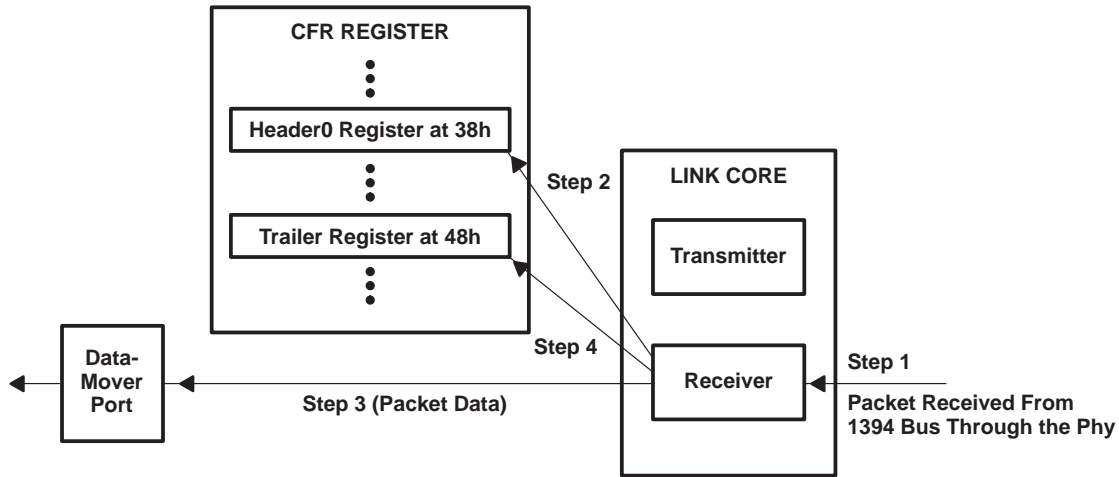

Figure 5–5. Isochronous Receive With Auto Header and Trailer Removal

### 5.1.1.2 Isochronous Packet Receive With Header and Trailer

- Step 1:** Isochronous packet is received through the receiver block of the link core.
- Step 2:** The header quadlet is both loaded into the header0 register at 38h and routed to the DM port without any buffering.
- Step 3:** Packet data (payload only) is sent directly through the DM port only.
- Step 4:** Trailer quadlet is loaded into the trailer register at 48h. It is also forwarded to the DM port.

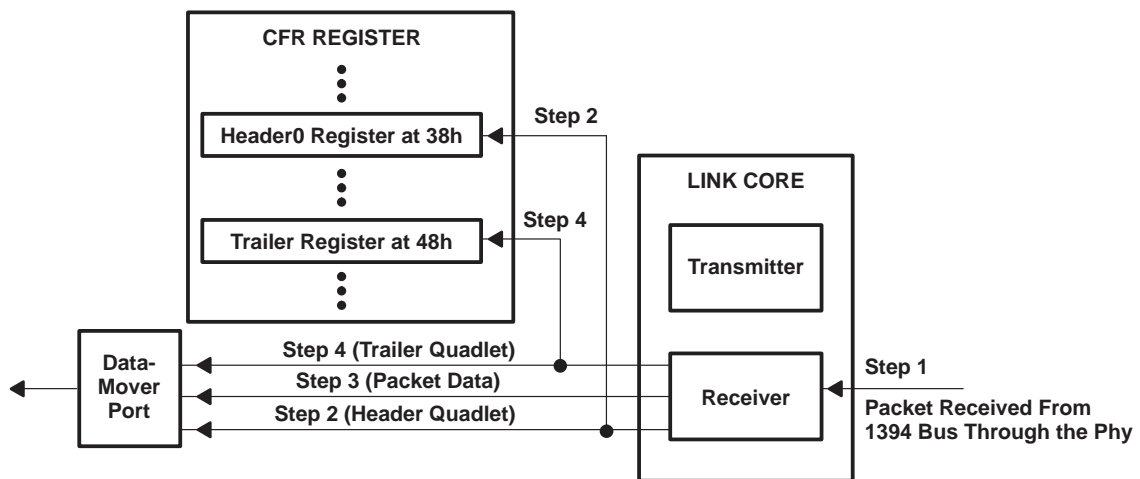

Figure 5–6. Isochronous Receive With Header and Trailer

## 5.1.2 Isochronous Transmit

There are two ways (modes of operation) to transmit isochronous data through the data mover:

- Isochronous packet transmit with automatic header insertion.
- Isochronous packet transmit without automatic header insertion.

The difference between the two modes lies in the mechanism with which the header information is inserted into the data stream. However, in both cases the header information is always loaded into the link core transmitter from the header register starting with the CFR at 38h. There are no trailers for transmitted packets.

**NOTE:** With a camera application, if the sync bit field in the isochronous header quadlet needs to be changed more than once during the transmission of a data block (i.e., one frame), the header information must be applied manually through the data-mover port.

### 5.1.2.1 Isochronous Packet Transmit With Automatic Header Insertion

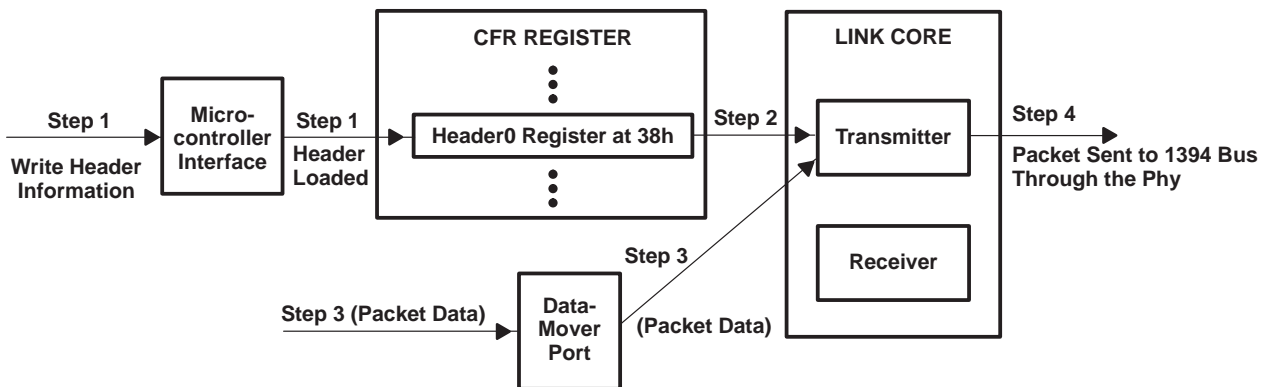

Figure 5–7. Isochronous Transmit With Auto Header Insertion

In this mode, the isochronous header information is first loaded into the Header0 Register at 38h through the microcontroller interface. Subsequently, the header is inserted automatically into the data once the data mover starts streaming data through to the link core transmitter logic. The following steps further illustrate the process.

- Step 1:** Isochronous header quadlet is loaded into the header0 register at 38h through a write operation from the microcontroller interface.
- Step 2:** Header quadlet is forwarded to the transmitter of the link core.
- Step 3:** Packet data (payload only) is transmitted through the data mover directly to the transmitter of the link core.
- Step 4:** Isochronous packet is sent to the 1394 bus through the Phy.

**NOTE:** The data coming through the data-mover port is typically supplied by an external fast memory block (i.e., FIFO, DRAM). This external memory logic can begin transmitting data through to the data-mover port exactly one DMCLK cycle after the DMPRE output pin on the GP2Lynx is asserted high.



### 5.1.2.2 Isochronous Packet Transmit Without Automatic Header Insertion

In this mode, both the packet header and data payload is loaded through the data-mover port. This mode is sometimes called isochronous packet transmit with manual header insertion. This is because the header quadlet is not preloaded into the header0 register via the microcontroller interface. Instead, it is inserted *manually* into the data stream at the same time as the rest of the packet. The following steps further illustrate the process.

- Step 1:** Isochronous header information (only one header quadlet in this case) is fetched into the header0 register at 38h through the data-mover port.
- Step 2:** Header quadlet is forwarded to the transmitter of the link core.
- Step 3:** Packet data (payload only) is transmitted through the data mover directly to the transmitter of the link core.
- Step 4:** Isochronous packet is sent to the 1394 bus through the Phy.

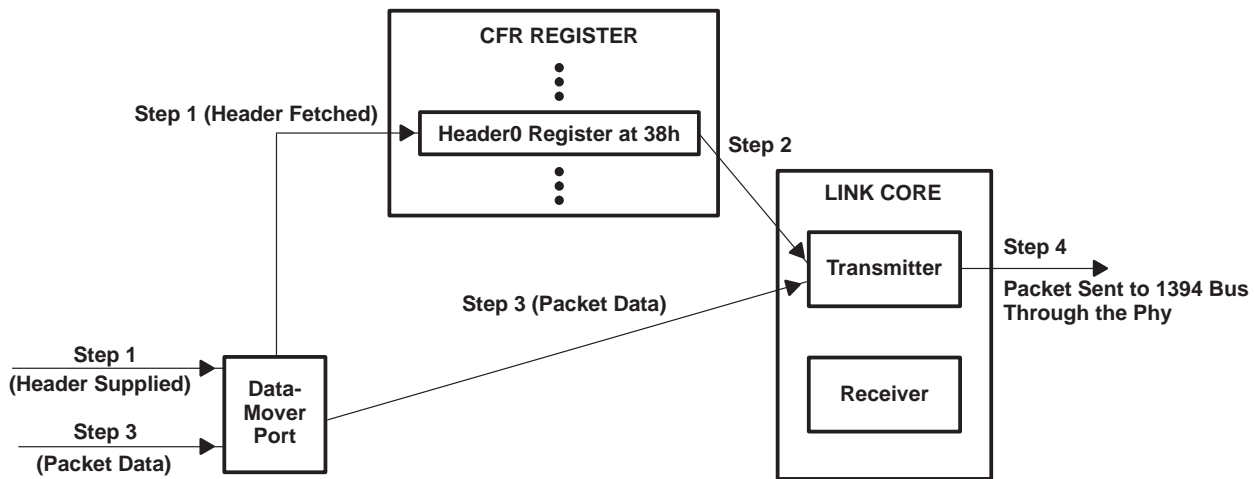

Figure 5–8. Isochronous Transmit Without Auto Header Insertion

### 5.1.3 Asynchronous Receive

In both the asynchronous receive modes, the packet header information is always loaded into the header registers in the CFR. In quadlet receive mode, the first three header quadlets are loaded into the header0 register at 38h, header1 register at 3Ch, and header2 register at 40h, respectively. In block receive mode, an additional step is performed, loading the fourth header quadlet received into the header3 register at 44h. The trailer quadlet always is loaded into the trailer register at 48h.

#### 5.1.3.1 Asynchronous Packet Receive With Automatic Header and Trailer Removal

- Step 1:** Asynchronous packet is received through the receiver logic of the link core
- Step 2:** The packet headers are stripped from the packet and loaded into the header registers:
- If in quadlet receive mode, the three header quadlets are loaded into the header0–header2 registers.
  - If in block receive mode, the four header quadlets are loaded into the header0–header3 registers.
- Step 3:** Packet data (payload only) is routed directly to the DM port without any buffering.
- Step 4:** Trailer quadlet is loaded into the trailer register at 48h.

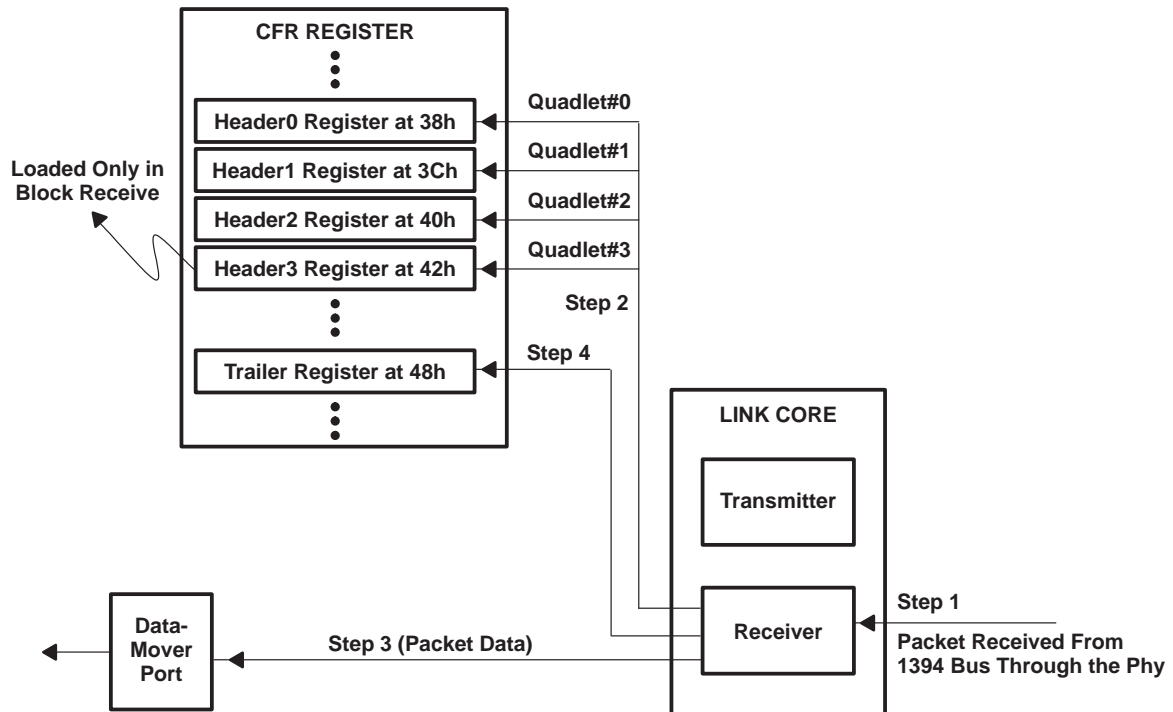

Figure 5–9. Asynchronous Receive Without Header and Trailer Removal

### 5.1.3.2 Asynchronous Packet Receive With Headers and Trailer

- Step 1:** Asynchronous packet is received through the receiver logic of the link core.
- Step 2:** The header quadlets are loaded into their respective header registers and routed to the DM port without any buffering.
- Step 3:** Packet data is routed directly to the DM port (no buffering performed).
- Step 4:** Trailer quadlet is loaded into the trailer register at 48h and routed to the DM port.

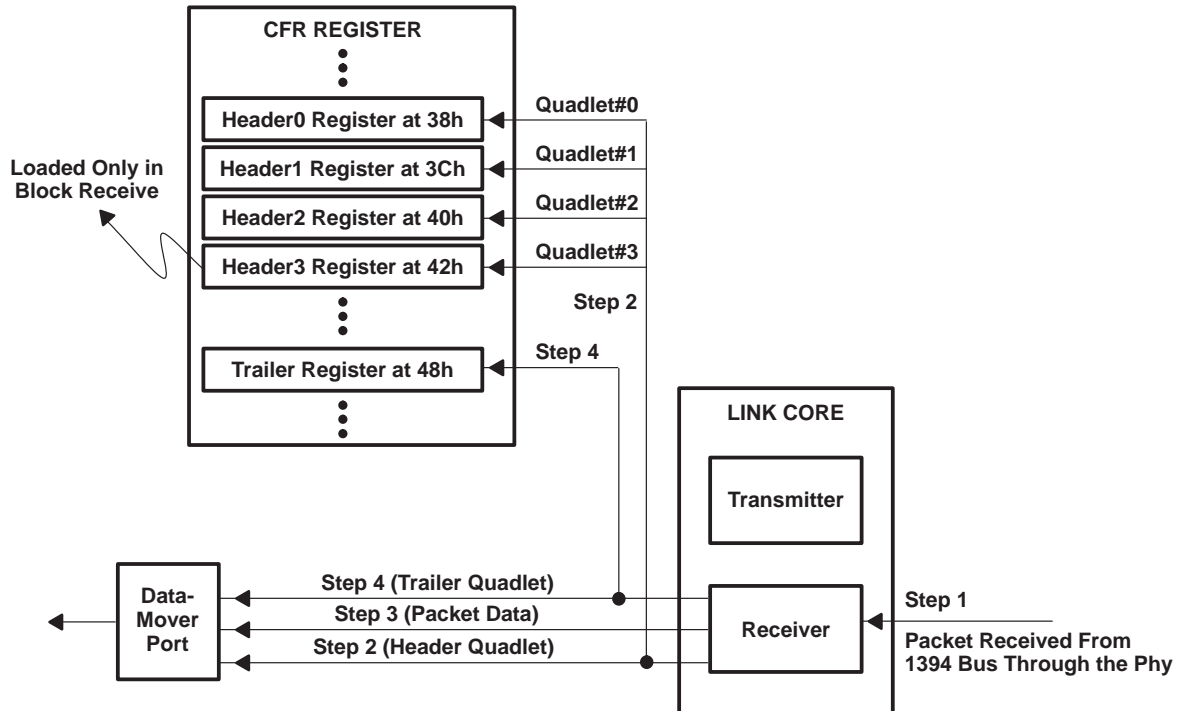

Figure 5–10. Asynchronous Receive With Headers and Trailer

### 5.1.4 Asynchronous Transmit

There are two ways (modes of operation) to transmit asynchronous data through the data mover:

- Asynchronous packet transmit with automatic header insertion
- Asynchronous packet transmit without automatic header insertion

The difference between the two modes is in the mechanism with which the header information is inserted into the data stream. However, in both cases, the header information is always loaded into the link core transmitter from the header registers starting with the CFR at 38h. There are no trailers for transmitted packets.

### 5.1.4.1 Asynchronous Packet Transmit With Automatic Header Insertion

In this mode, the header information is first loaded into the header0–header3 registers through the microcontroller interface. The headers subsequently are inserted automatically into the data once the data mover starts streaming data through to the link core transmitter logic. The following steps further illustrate the process.

- Step 1:** Asynchronous header quadlets (three quadlets in quadlet mode and four quadlets in block mode) are loaded into the header0–header3 registers through a write operation from the microcontroller interface. Loading each header quadlet requires a single write operation.
- Step 2:** Header quadlets are forwarded to the transmitter of the link core.
- Step 3:** Packet data (payload only) is transmitted through the data mover directly to the transmitter of the link core.
- Step 4:** Asynchronous packet is sent to the 1394 bus through the Phy.

**NOTE:** The data coming through the data-mover port is typically supplied by an external fast memory block (i.e., FIFO, DRAM). This external memory logic can begin transmitting data through to the data-mover port exactly one DMCLK cycle after the DMPRE output pin on the GP2Lynx is asserted high.

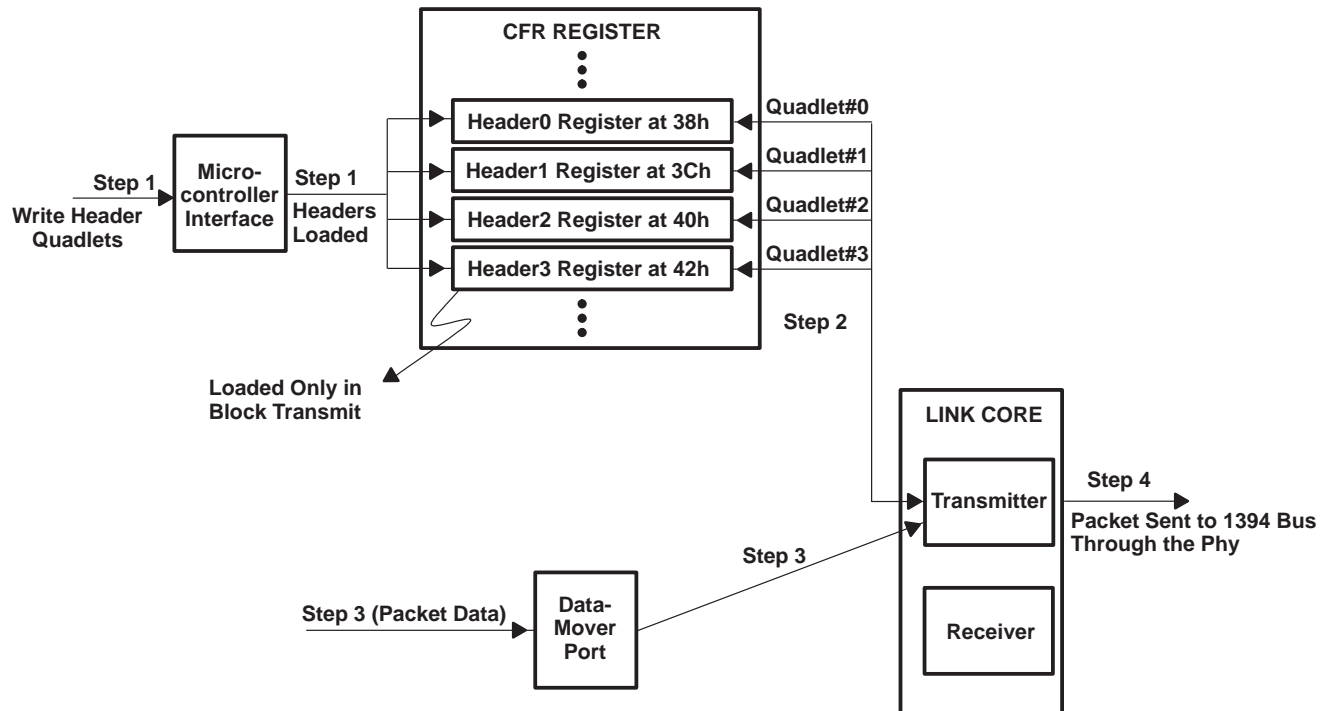

Figure 5–11. Asynchronous Transmit With Auto Header Insertion

### 5.1.4.2 Asynchronous Packet Transmit Without Automatic Header Insertion

In this mode, the packet headers and data information are loaded through the data-mover port. This mode is sometimes called asynchronous packet transmit with manual header insertion. This is because the header quadlets are not preloaded into the header registers via the microcontroller interface. Instead, they are inserted *manually* into the data stream at the same time as the rest of the packet. The following steps further illustrate the process.

- Step 1:** Asynchronous header quadlets (three quadlets in quadlet mode and four quadlets in block mode) are fetched into the header registers through the data-mover port.
- Step 2:** The header quadlets are then forwarded to the transmitter of the link core.
- Step 3:** Packet data (payload only) is transmitted through the data mover directly to the transmitter of the link core.
- Step 4:** Asynchronous packet is sent to the 1394 bus through the Phy.

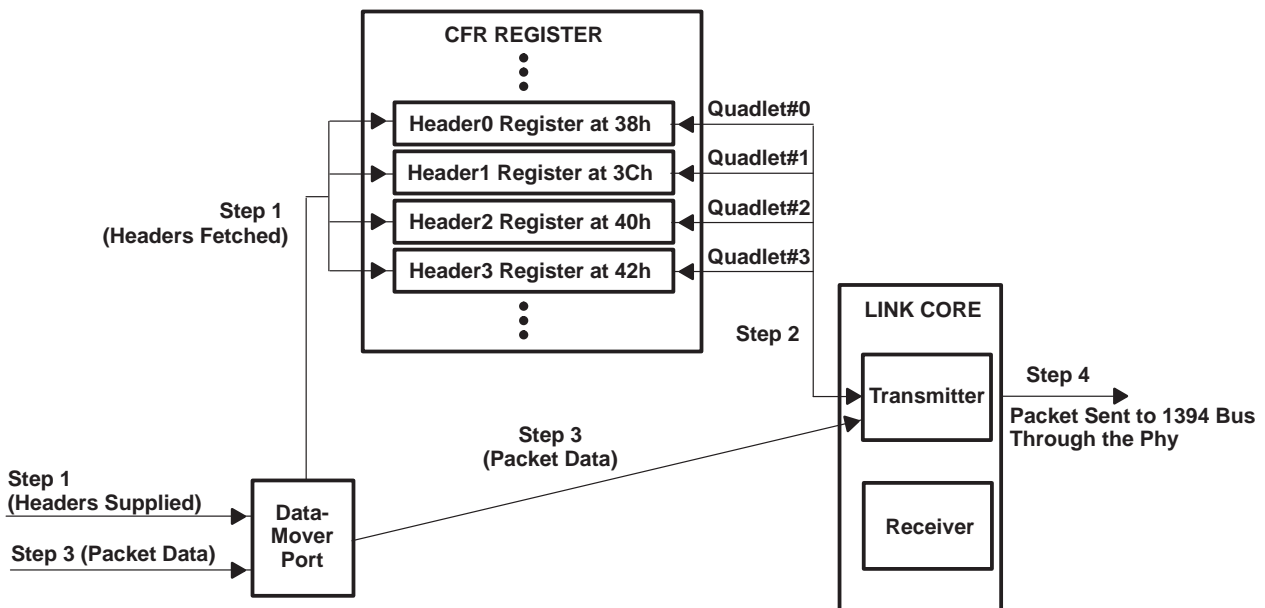

Figure 5–12. Asynchronous Transmit Without Auto Header Insertion

## 5.2 Data-Mover Modes of Operation

The data-mover (DM) port in the GP2Lynx is meant to handle an external memory interface that supplies or accepts large data packets. The port can be configured to either transmit or receive data packets. The data can be either asynchronous or isochronous packets. All traffic through the data mover is synchronous to the rising edge of DMCLK. DMCLK is an output signal at 24.576 MHz.

The data mover operates by setting bits within the DM control register at 04h. The data mover has eight modes of operation which are specified by the DMASYNC, DMHDR, and DMRX bits in the DM control register at 04h. Table 5–1 shows all the DM modes of operation.

Table 5–1. Modes of Operation

DMASYNC	DMHDR	DMRX	MODE OF OPERATION
0	0	0	Isochronous packet transmit with auto header insertion
0	0	1	Isochronous packet receive with auto header and trailer removal
0	1	0	Isochronous packet transmit without auto header insertion
0	1	1	Isochronous packet receive with header and trailer
1	0	0	Asynchronous packet transmit with auto header insertion
1	0	1	Asynchronous packet receive with auto header and trailer removal
1	1	0	Asynchronous packet transmit without auto header insertion
1	1	1	Asynchronous packet receive with headers and trailer

### 5.2.1 Isochronous Transmit With Automatic Header Insertion

Upon receiving a high on DMREADY, the following sequence of operations is performed.

- Step 1:** DMDONE is asserted low (deactivated) at the next DMCLK cycle.
- Step 2:** The data mover takes the header that has been loaded into the header0 register at 38h and requests the link core to transmit the data onto the 1394 bus.
- Step 3:** The link core fetches the header from the header0 register.
- Step 4:** DMPRE pulses for one DMCLK cycle before the first data quadlet is accepted by GP2Lynx from the external device.
- Step 5:** The data mover then begins to fetch the data payload by asserting DMRW high.
- Step 6:** When the link core has fetched the last data quadlet, the data mover checks the number of channels specified in the CHNLCNT field in the DM control register at 04h to verify whether a data packet has been sent on each isochronous channel. If all channels have been sent, the data mover waits for a subaction gap to occur before asserting DMDONE high to indicate the end of the cycle. Otherwise the data mover provides the header in the next header register and then begins fetching the data payload until all channels are complete. A data packet must be sent on each active isochronous channel.

The timing diagrams in Figure 5–13 through Figure 5–15 illustrate this mode of operation at different transmit speeds. For simplification, these diagrams show three quadlets of data payload.

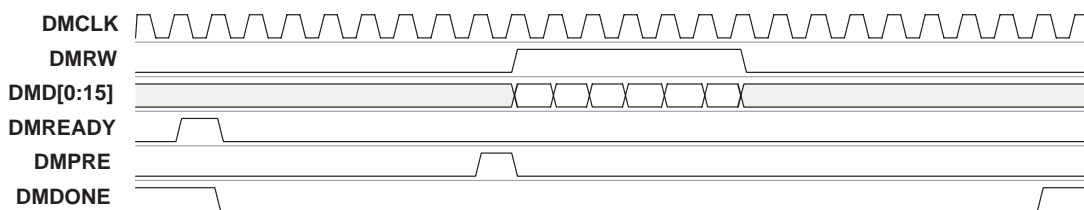

Figure 5–13. Isochronous Transmit With Auto Header Insertion at 400 Mbps

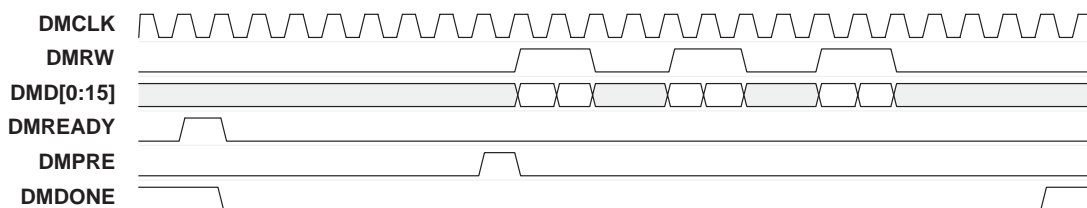

Figure 5–14. Isochronous Transmit With Auto Header Insertion at 200 Mbps

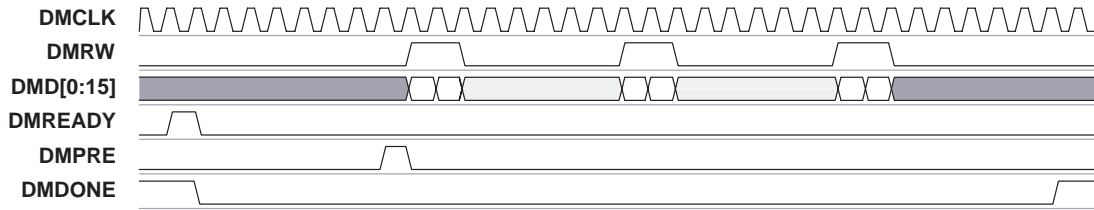

Figure 5–15. Isochronous Transmit With Auto Header Insertion at 100 Mbps

### 5.2.2 Isochronous Transmit Without Automatic Header Insertion

Upon receiving a high on DMREADY, the following sequence of operations is performed.

- Step 1:** DMDONE is driven low (deactivated) at the next DMCLK cycle.
- Step 2:** DMPRE pulses for one DMCLK cycle before the first header quadlet is accepted from the external device.
- Step 3:** The data mover fetches the header by asserting DMRW high.
- Step 4:** The data mover then loads the header into the header0 register and requests the data to be transmitted out on the 1394 bus by the link core.
- Step 5:** The link fetches the header from the header0 register.
- Step 6:** DMPRE pulses for one DMCLK cycle before the first data quadlet is accepted from the external device.
- Step 7:** The data mover then begins to fetch the data payload by asserting DMRW high.
- Step 8:** When the link core has fetched the last data quadlet, the data mover checks the number of channels specified in the CHNLCNT field in the DM control register to verify whether a data packet has been sent on each isochronous channel. If all channels have been sent, the data mover waits for a subaction gap to occur before asserting DMDONE high to indicate the end of the cycle. Otherwise the data mover provides the header in the next header register and then begins fetching the data payload until all channels are complete. A data packet must be sent on each active isochronous channel.

Figure 5–16 shows the timing diagram for this mode at a data transmit rate of 400 Mbps. The dashed sections indicate repetitive behavior (when the payload is more than two quadlets long).

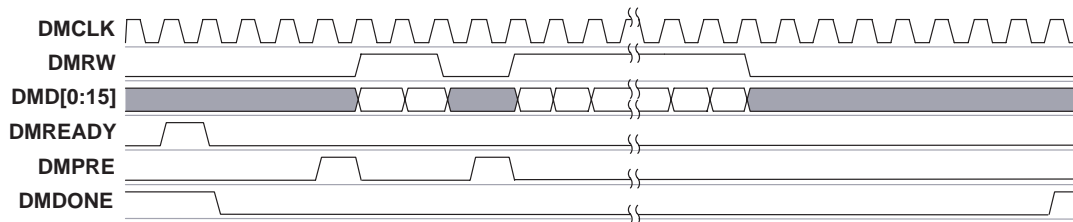

Figure 5–16. Isochronous Transmit Without Automatic Header Insertion

### 5.2.3 Isochronous Packet Receive With Automatic Header and Trailer Removal

In this mode, when the link receives an isochronous packet that is addressed to it, the following sequence of operations is performed.

- Step 1:** The packet router control logic routes the packet to the data mover. If the sync bit field in the header quadlet matches a bit pattern in the ISYNCRCVN field of the isochronous port register at 18h, DMPRE is asserted high for one DMCLK cycle.
- Step 2:** After the header is sent through, DMDONE is asserted high for one DMCLK cycle. DMRW is then asserted high as the data payload comes through.
- Step 3:** After all data has been transmitted on the DMD[0:15] lines, DMRW is asserted low and the trailer quadlet then comes out on the DMD[0:15] lines.

PKTFLAG is never asserted high in this mode. Figure 5–17 shows the timing diagram for this mode at 400 Mbps. Figure 5–17 shows the case where DMPRE is asserted high for one DMCLK cycle to indicate that the sync bits of the received isochronous header match the contents of the ISYNCRCVN field.

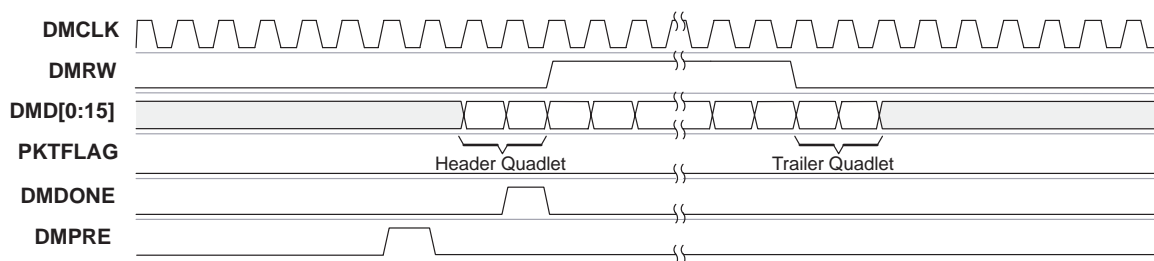

Figure 5–17. Isochronous Receive With Automatic Header and Trailer Removal



### 5.2.4 Isochronous Packet Receive With Header and Trailer

In this mode, when the link receives an isochronous packet that is addressed to it, the following sequence of operations is performed.

- Step 1:** The packet router control logic routes the packet to the data mover. If the sync bit field in the header quadlet matches a bit pattern in the ISYNCRCVN field of the isochronous port register at 18h, DMPRE is asserted high for one DMCLK cycle. At the same time, DMDONE is asserted high for one DMCLK cycle.
- Step 2:** This is followed by DMRW asserted high as the packet comes through. PKTFLAG is only asserted high when the header quadlet is being received.
- Step 3:** After all the data payload has been transmitted on the DMD[0:15] lines, PKTFLAG is asserted high again as the trailer quadlet is being transmitted. Once the entire packet is transmitted, the DMRW line is asserted low.

Figure 5–18 shows the timing diagram for this mode at 400 Mbps. Also, Figure 5–18 shows the case where DMPRE is asserted high for one DMCLK cycle to indicate that the sync bits of the received isochronous header matches the contents of the ISYNCRCVN field.

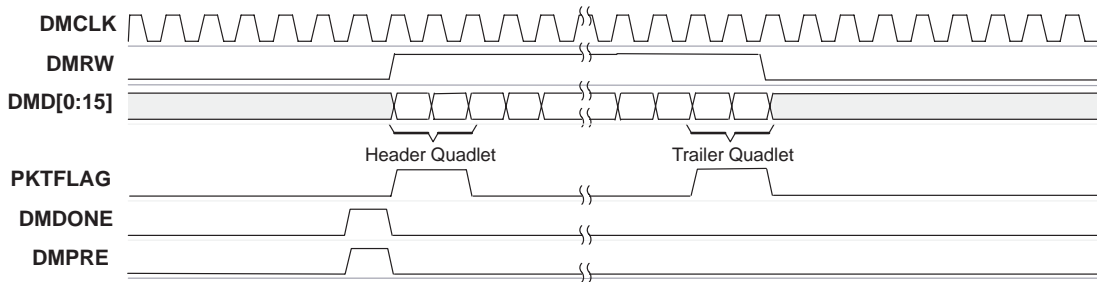

Figure 5–18. Isochronous Receive With Header and Trailer

Figure 5–19 shows the timing diagram at 200 Mbps when the received packet contains only one quadlet of payload.

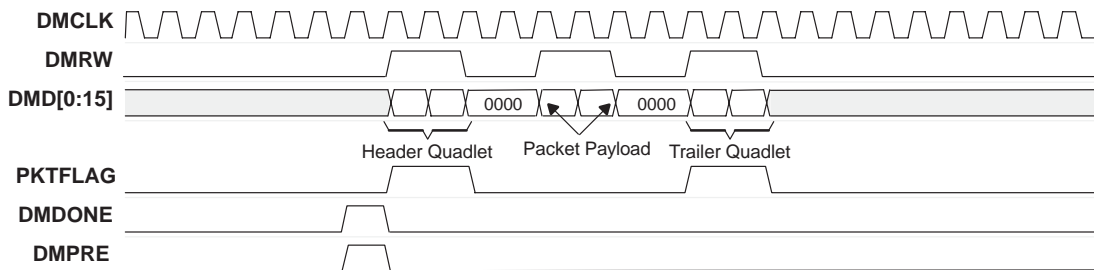

Figure 5–19. Isochronous Receive With Header and Trailer at 200 Mbps

### 5.2.5 Asynchronous Packet Transmit With Automatic Header Insertion

Upon receiving a high signal on DMREADY from the external logic, the following sequence of operations is performed.

- Step 1:** DMDONE is asserted low (deactivated) at the next DMCLK cycle.
- Step 2:** The data mover takes the headers that have been loaded into the header0–header3 registers and requests the link core to transmit the data onto the 1394 bus.
- Step 3:** The link core fetches the headers from the header0–header3 registers.
- Step 4:** DMPRE pulses for one DMCLK cycle before the first data quadlet is accepted from the external device on the DM port.
- Step 5:** The data mover then begins to fetch the data payload by asserting DMRW high.
- Step 6:** When the link core has fetched the last data quadlet, the data mover waits until the destination node returns an *ack\_complete* immediate response. If an *ack\_complete* is not received, the data mover asserts DMERROR high and becomes disabled.

Figure 5–20, Figure 5–21, and Figure 5–22 show the timing diagram for this mode for the quadlet transmit and the block transmit cases, respectively. For simplicity, a data block size of three quadlets was selected in Figure 5–20. Figure 5–22 shows the block transmit case at 400 Mbps.

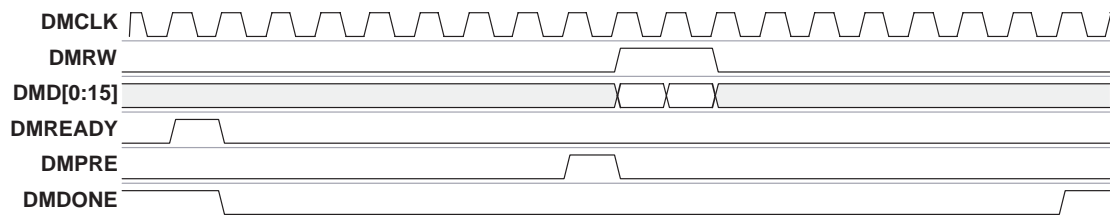

Figure 5–20. Asynchronous Quadlet Transmit With Automatic Header Insertion

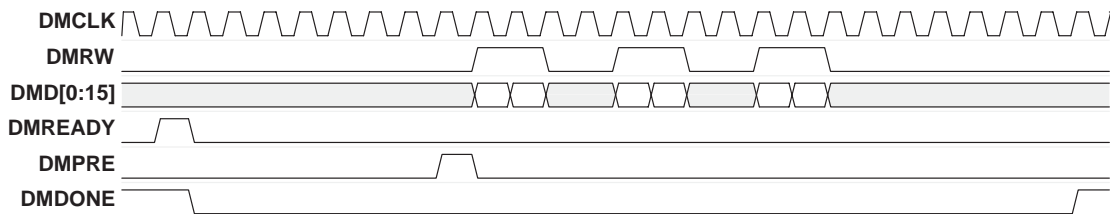

Figure 5–21. Asynchronous Block Transmit With Automatic Header Insertion at 200 Mbps

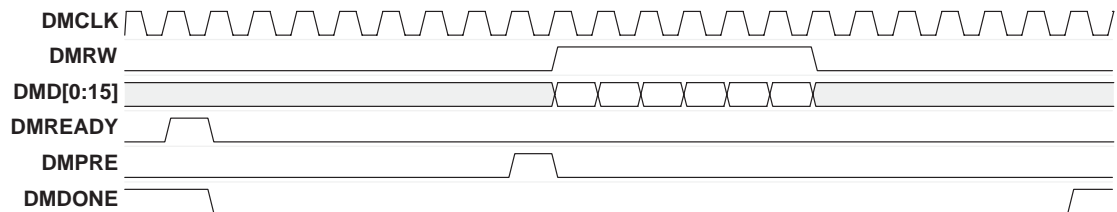

Figure 5–22. Asynchronous Block Transmit With Automatic Header Insertion at 400 Mbps

### 5.2.6 Asynchronous Packet Transmit Without Automatic Header Insertion

Upon receiving a high signal on DMREADY from the external logic, the following sequence of operations is performed.

- Step 1:** DMDONE is asserted low (deactivated) at the next DMCLK cycle.
- Step 2:** DMPRE pulses for one DMCLK cycle before the header quadlets are accepted from the external device on the DM port.
- Step 3:** The data mover fetches the headers by asserting DMRW high.
- Step 4:** The data mover then loads the headers into the header0–header3 registers and requests the data to be transmitted out on the 1394 bus by the link core.
- Step 5:** The link fetches the headers.
- Step 6:** DMPRE pulses for one DMCLK cycle before the first data quadlet is accepted from the external device on the DM port.
- Step 7:** The data mover then begins to fetch the data payload by asserting DMRW high.
- Step 8:** When the link core has fetched the last data quadlet, the data mover waits until the destination node returns an *ack\_complete* immediate response. If an *ack\_complete* is not received, the data mover asserts DMERROR high and becomes disabled.

Figure 5–23 and Figure 5–24 show the timing diagram for this mode for the quadlet transmit and the block transmit cases, respectively. For simplicity, a data block size of three quadlets was selected in Figure 5–24.

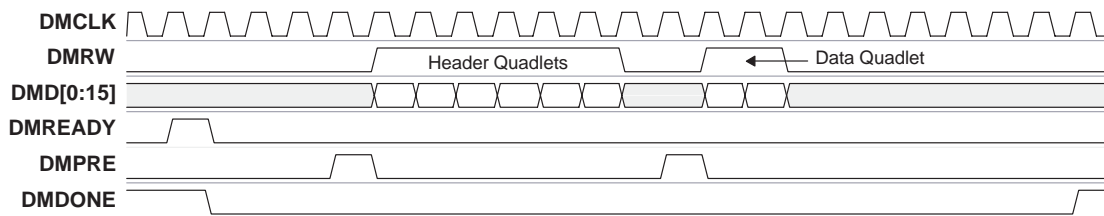

Figure 5–23. Asynchronous Quadlet Transmit Without Automatic Header Insertion at 400 Mbps

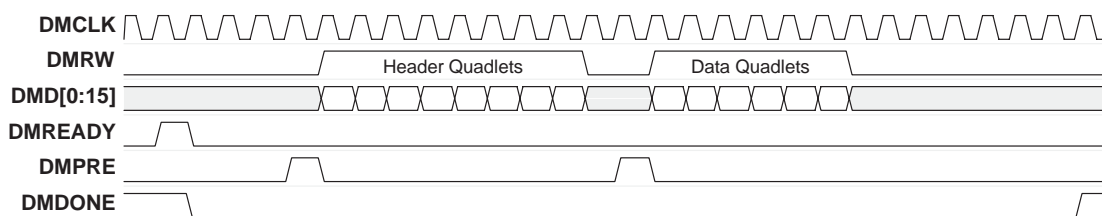

Figure 5–24. Asynchronous Block Transmit Without Automatic Header Insertion at 400 Mbps

### 5.2.7 Asynchronous Packet Receive With Headers and Trailer

In this mode, when the link receives an asynchronous packet that is addressed to it, the following sequence of operations is performed.

- Step 1:** The packet router control logic routes the packet to the data mover. At the same time, DMDONE is asserted high for one DMCLK cycle.
- Step 2:** This is followed by DMRW asserted high as the packet comes through. PKTFLAG is only asserted high when the header quadlets are being received.
- Step 3:** After all the data payload has been received on the DMD[0:15] lines, PKTFLAG is asserted high again as the trailer quadlet is being received. Once the entire packet is received, the DMRW line is asserted low.

Figure 5–25 and Figure 5–26 show the timing diagram for this mode for the quadlet receive and the block receive cases, respectively. For simplicity, a data block size of three quadlets was selected in Figure 5–26.

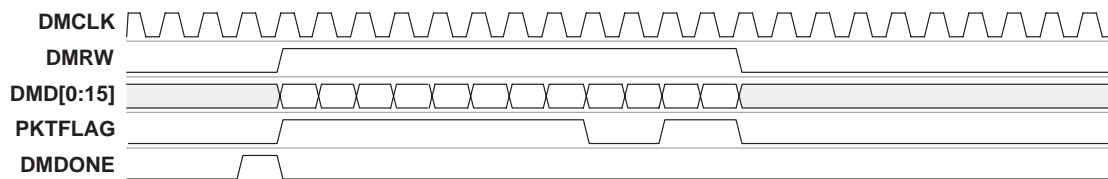

Figure 5–25. Asynchronous Quadlet Receive With Headers and Trailer at 400 Mbps

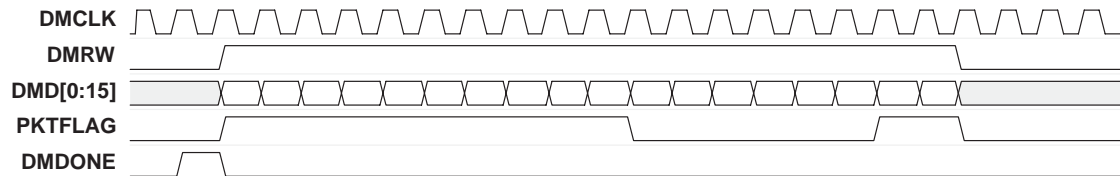

Figure 5–26. Asynchronous Block Receive With Headers and Trailer at 400 Mbps

### 5.2.8 Asynchronous Packet Receive With Automatic Header and Trailer Removal

In this mode, when the link receives an asynchronous packet that is addressed to it, the following sequence of operations is performed.

- Step 1:** The packet router control logic routes the packet to the data mover. After the headers are sent through, DMDONE is asserted high for one DMCLK cycle.
- Step 2:** DMRW is then asserted high as the data payload comes through.
- Step 3:** After all data has been received on the DMD[0:15] lines, DMRW is asserted low and the trailer quadlet then comes out on the DMD[0:15] lines.

Figure 5–27 and Figure 5–28 show the timing diagram for this mode for the quadlet receive and the block receive cases, respectively. For simplicity, a data block size of three quadlets was selected in Figure 5–28.

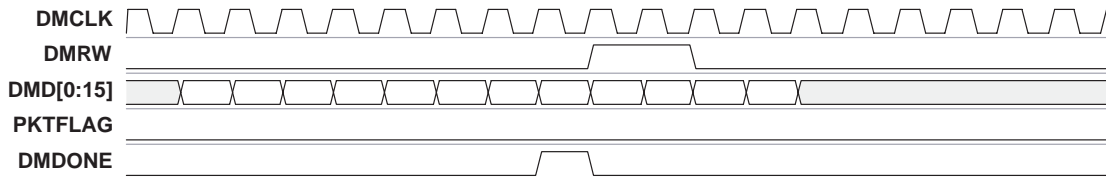

Figure 5–27. Asynchronous Quadlet Receive With Automatic Header and Trailer Removal at 400 Mbps

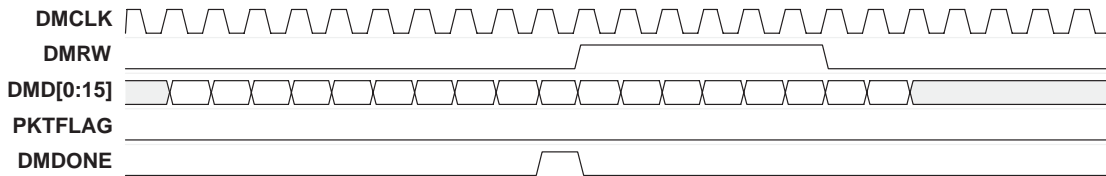

Figure 5–28. Asynchronous Block Receive With Automatic Header and Trailer Removal at 400 Mbps

### 5.3 Data-Mover Byte Mode

In this mode the DMD lines are only 1 byte wide when the maximum speed is 200 Mbps. Only the DMD[0:7] bits are used for the data bus. DMERROR is asserted if transmission of a 400-Mbps packet is attempted.

### 5.4 Data-Mover Endian Swapping

In this mode the DMD[0:15] bytes are swapped. If the data mover is in byte mode, the least significant byte is fetched first (see Figure 5–29). If the data mover is not in byte mode, the least significant word is fetched first and the byte order is then swapped (see Figure 5–30).

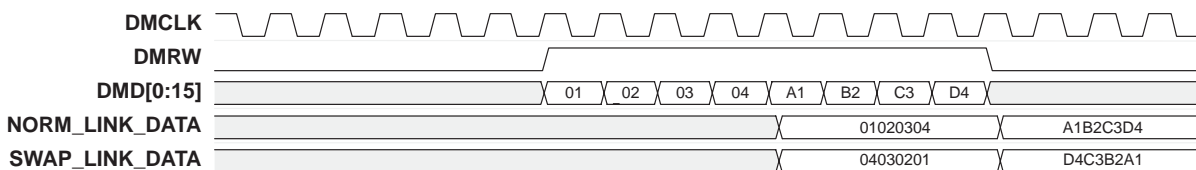

Figure 5–29. Endian Swapping in Byte Mode

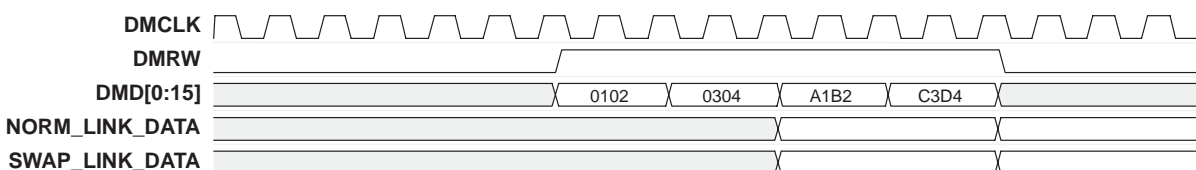

Figure 5–30. Endian Swapping in Word Mode

## 5.5 Data-Mover Handshake Mode

In this mode, when DMDONE is asserted high the data-mover port interface checks for DMREADY low as an acknowledge. This is equivalent to the mode used in the TSB12LV31 (GPLynx), as shown in Figure 5–31.

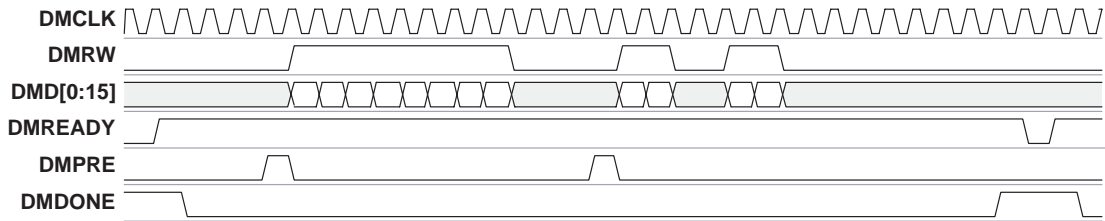

Figure 5–31. Data-Mover Handshake Mode (GPLynx Mode)

## 5.6 Data-Mover Critical Timing

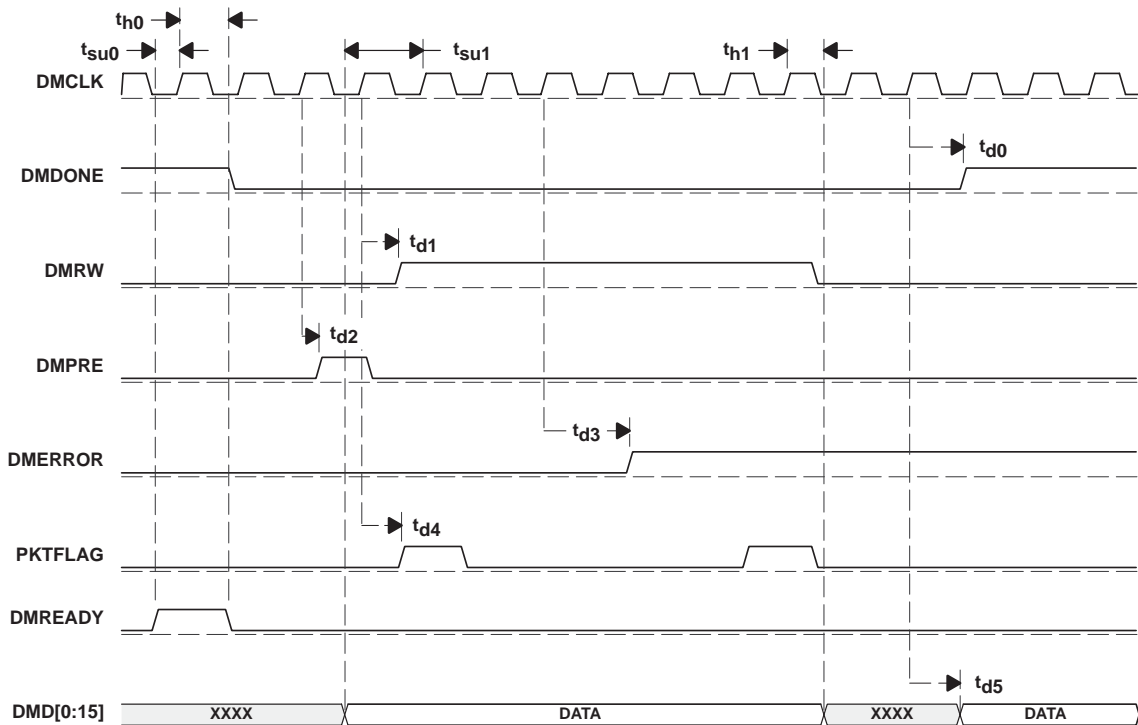

Figure 5–32. Clock-to-Output Timing With Respect to DMCLK

Table 5–2. CLK-to-Output Timing With Respect to DMCLK

PARAMETER†		TERMINAL NAME	MIN	MAX	UNIT
$t_{d0}$	Delay time (DMCLK to Q)	DMDONE	1.75	8.5	ns
$t_{d1}$		DMRW	1.75	7.5	
$t_{d2}$		DMPRE	1.75	14.5	
$t_{d3}$		DMERROR	1.5	11.5	
$t_{d4}$		PKTFLAG	1.75	8.5	
$t_{d5}$		DMD[0:15]	0.5	9	
$t_{su0}$		Setup time to DMCLK	DMREADY	14	
$t_{su1}$	DMD[0:15]		14		
$t_{h0}$	Hold time from DMCLK	DMREADY	1	ns	
$t_{h1}$		DMD[0:15]	0.75		

† All timing parameters are referenced to the rising edge of DMCLK.



## 6 FIFO Memory Access

The TSB12LV32 FIFO interfaces with the microcontroller, the CFR and the 1394 link layer controller (LLC). The FIFO is separated into an asynchronous transmit FIFO (ATF) and a general receive FIFO (GRF), each of 520 quadlets (2K bytes). The FIFO provides storage for transmit packets (ATF) and receive packets (GRF). When an asynchronous packet is confirmed into the ATF, the transmitter of the LLC requests the 1394 bus to send the asynchronous packet. When a received packet is confirmed into the GRF by the receiver of the LLC without any errors, interrupt RXGRFPKT in the interrupt register at 0Ch is triggered so the microcontroller interface can read the received data from the GRF. Access to all FIFO memories is fundamentally the same, only the address written to changes. Figure 6–1 shows the FIFO-address access map.

	0	1	2	3	4	5	6	7	8	9	10	11	12	13	14	15	16	17	18	19	20	21	22	23	24	25	26	27	28	29	30	31
50h	ATF_First																															
54h	ATF_Continue																															
58h	ATF_Continue&Update																															
5Ch	ATF_Burst_Write																															
60h	GRF Data																															
64h	Reserved																															
68h	ATF_First_Update																															

Figure 6–1. TSB12LV32 Controller-FIFO-Access Address Map

### 6.1 General

The suffix *\_First* in Figure 6–1 denotes an address that accesses the FIFO location where the first quadlet of a packet should be written to transmit the packet. The first quadlet is held in the FIFO until a quadlet is written to an *Update* address and the packet is transmitted. The suffix *\_Continue* in Figure 6–1 denotes an address that accesses the FIFO location where the second through  $n-1$  quadlets of a packet should be written, where  $n$  is the total number of quadlets in the packet. The second through  $n-1$  quadlets are held in the FIFO until a quadlet is written to an *Update* address and the packet is transmitted. The suffix *\_Continue & Update* in Figure 6–1 denotes an address that accesses the FIFO location where the last quadlet of a multiple ( $n$ ) quadlet packet should be written so that the packet is confirmed for transmission.

### 6.2 ATF Access

The ATF consists of a 520 quadlet RAM, a write buffer, and control logic. The ATF write buffer is a four-quadlet buffer used to temporarily store asynchronous packet data from the microcontroller interface to facilitate burst writes. Asynchronous packets can also be transmitted through the data-mover port, however the ATF always has transmission priority and its data will be sent first.

The procedure for accessing the ATF for a quadlet write operation is accomplished in three successive steps. To ensure that an ATF underflow condition does not occur, loading of the ATF in the following manner is highly recommended.

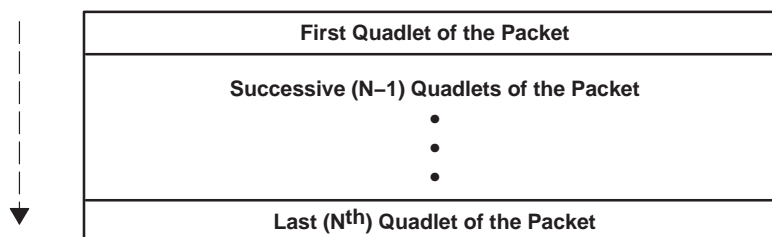

Figure 6–2. Asynchronous Packet With N Quadlets (ATF Loading Operation)



Each quadlet can be written into the ATF register on a byte (8-bit) boundary or word (16-bit) boundary. To write to the ATF in a byte fashion, the following steps should be followed.

**Step 1:** Writing the first quadlet of the packet:

- a) Write the first 8 bits of the quadlet to ATF location 50h.
- b) Write the second 8 bits of the quadlet to ATF location 51h.
- c) Write the third 8 bits of the quadlet to ATF location 52h.
- d) Write the fourth 8 bits of the quadlet to ATF location 53h.

The data is not yet confirmed for transmission.

**Step 2:** Writing the next (n–1) quadlets of the packet:

- a) Write the first 8 bits of each quadlet to ATF location 54h.
- b) Write the second 8 bits of each quadlet to ATF location 55h.
- c) Write the third 8 bits of each quadlet to ATF location 56h.
- d) Write the fourth 8 bits of each quadlet to ATF location 57h.

The data is not yet confirmed for transmission.

**Step 3:** Last (N<sup>th</sup>) quadlet of the packet:

- a) Write the first 8 bits of the quadlet to ATF location 58h.
- b) Write the second 8 bits of the quadlet to ATF location 59h.
- c) Write the third 8 bits of the quadlet to ATF location 5Ah.
- d) Write the fourth 8 bits of the quadlet to ATF location 5Bh.

The data is now confirmed for transmission.

To write to the ATF in a word fashion, the following steps should be followed.

**Step 4:** Writing the first quadlet of the packet:

- a) Write the first 16 bits of the quadlet to ATF location 50h.
- b) Write the second 16 bits of the quadlet to ATF location 52h.

The data is not yet confirmed for transmission.

**Step 5:** Writing the next (n–1) quadlets of the packet:

- a) Write the first 16 bits of each quadlet to ATF location 54h.
- b) Write the second 16 bits of each quadlet to ATF location 56h.

The data is not yet confirmed for transmission.

**Step 6:** Last (N<sup>th</sup>) quadlet of the packet:

- a) Write the first 16 bits of the quadlet to ATF location 58h.
- b) Write the second 16 bits of the quadlet to ATF location 5Ah.

The data is now confirmed for transmission.

All writes to the ATF must be quadlet aligned (i.e., only an even number of write accesses is allowed). If the first quadlet of a packet is not written to the ATF\_First location, the transmitter enters a state denoted by an ATSTK interrupt in the interrupt register at 0Ch. An underflow of the ATF also causes an ATSTK interrupt. When this ATF\_Stuck state is entered, no asynchronous packets can be sent until the ATF is cleared by way of the ATFCLR control bit (bit 0 in FIFO status CFR at 30h). Isochronous packets still can be sent while the ATF is in the ATF\_Stuck state.

### 6.3 ATF Burst Access

It is possible to perform a burst write into the address location ATF\_Continue at 54h, which allows multiple quadlets to load into ATF, but the data packet is not confirmed for transmission until an update address is written. It is not possible to perform a burst write into the address location ATF\_Continue&Update at 58h, which loads the last quadlet of a packet into ATF and confirms the data for transmission.

Burst write accesses to the address location 5Ch or ATF\_Burst\_Write can write the entire packet into the ATF from one address. The last quadlet written into ATF confirms the packet for transmission.

To perform a burst write operation, the microcontroller must continually drive  $\overline{MCS}$  low. The TSB12LV32 loads MD0–MD15 to the ATF during each rising edge of BCLK while  $\overline{MCS}$  is low. At the same time it asserts  $\overline{MCA}$  ( $\overline{MCA}$  is always one cycle behind  $\overline{MCS}$ ) low.

The ATF\_First\_Update address location is optimized for transmitting zero-length isochronous packets or asynchronous stream packets. A zero-length packet contains no data payload and only the packet header and header CRC are transmitted.

## 6.4 General-Receive FIFO (GRF)

The GRF contains a 520 quadlet RAM, a prefetch buffer and control logic. When the received packet has been verified and the GRF RAM has enough space to hold the whole packet (CRCs not included), the hardware triggers a receive packet interrupt, RXGRFPKT, in the interrupt register at 0Ch and the GRF prefetch buffer automatically reads the data from the RAM. The GRF prefetch buffer is used to support the microinterface burst read operation. Microcontroller read access to the GRF is performed by a read from the address location 60h, GRF Data.

The GRF accumulates self-ID packets upon 1394 bus reset. All quadlets of a self-ID packet are saved in the GRF after power up. TSB12LV32 hardware checks to ensure that the second quadlet is indeed the complement (logical inverse) of the first quadlet of the self-ID. If there are any errors associated with the self-ID process, a self-ID interrupt, SELFIDER, is generated in the interrupt register at 0Ch and the self-ID error code field, SIDERCODE, at 08h is updated to reflect the error(s). The option to check for the logical inverse of the self-ID in the second quadlet can be turned off by setting to 0 the FULLSID bit in the control register at 08h.

## 6.5 GRF Stored Data Format

Each quadlet in the GRF is internally 33 bits wide. The most significant bit (extra bit) is used to indicate whether it is a packet token or a regular received quadlet (received header CRC and data CRC are checked and not stored in GRF). This bit is called the CD bit, which value is reflected in bit 6 of the FIFO status register. If the CD bit is 1, the next quadlet read from the GRF is a packet token. If the CD bit is 0, the next quadlet read from the GRF is a regular received quadlet. A packet token is stored as the first quadlet for each received confirmed packet. The definition for a packet token is shown in Table 6–1. Bit 0 is most significant bit and bit 32 is the least significant bit.

**Table 6–1. Packet Token Definition**

BITS	NAME	DESCRIPTION
0	CD	CD bit is 1 for packet token. This bit should only be read from the FIFO status register at 30h.
1–2	RESERVED	Reserved
3–16	QUADLET_COUNT	Expected quadlet count after packet token for this received packet
17–19	RESERVED	Reserved
20–24	ackCode	If bit 20 is 0, bits[21:24] are used as the Ack code that is sent back to the transmitting node. If bit 20 is 1, it is an error condition and an error Ack code is sent to the transmitting node.
25–26	RESERVED	Reserved
27–28	SPEED	The speed code for the received packet. 00 – 100 Mbps 01 – 200 Mbps 10 – 400 Mbps
29–32	RESERVED	Reserved



## 7 TSB12LV32 Data Formats

The data formats for transmission and reception of data are shown in the following sections. The transmit format describes the expected organization of data presented to the TSB12LV32 at the data-mover port or the microcontroller interface. The receive formats describe the data format that the TSB12LV32 presents to the data-mover port or the microcontroller interface.

### 7.1 Asynchronous Transmit/Receive (Microcontroller Interface/Data-Mover Port to/From TSB12LV32)

Asynchronous transmit refers to the use of the asynchronous-transmit FIFO (ATF) interface or data-mover port to transmit asynchronous data packets. The general-receive FIFO (GRF) and the data-mover port can receive asynchronous data packets and/or isochronous data packets. Data is received and transmitted in two basic formats. The first format is for quadlet packets, and the second format is for block packets. For transmission, the FIFO address accessed indicates the beginning, middle, and end of a packet. For receipt, the data length, which is found in the header of the packet, determines the number of bytes in a block packet.

#### 7.1.1 Quadlet Transmit

The quadlet transmit formats are shown in Figure 7–1 and are described in Table 7–1. The first quadlet contains packet control information. The second and third quadlets contain the 64-bit, quadlet-aligned address for read and write requests and retry codes for read and write responses. The fourth quadlet is data used only for write requests and read responses. For read requests and write responses, the quadlet data field is omitted.

0	1	2	3	4	5	6	7	8	9	10	11	12	13	14	15	16	17	18	19	20	21	22	23	24	25	26	27	28	29	30	31
														spd		tLabel			rt		tCode			priority							
destinationID														desination OffsetHigh																	
desination OffsetLow																															
quadlet data																															

Quadlet-Transmit Format (Write Request)

0	1	2	3	4	5	6	7	8	9	10	11	12	13	14	15	16	17	18	19	20	21	22	23	24	25	26	27	28	29	30	31
														spd		tLabel			rt		tCode			priority							
destinationID														rCode																	

Quadlet-Transmit Format (Write Response)

0	1	2	3	4	5	6	7	8	9	10	11	12	13	14	15	16	17	18	19	20	21	22	23	24	25	26	27	28	29	30	31
														spd		tLabel			rt		tCode			priority							
destinationID														desination OffsetHigh																	
desination OffsetLow																															

Quadlet-Transmit Format (Read Request)

0	1	2	3	4	5	6	7	8	9	10	11	12	13	14	15	16	17	18	19	20	21	22	23	24	25	26	27	28	29	30	31
														spd		tLabel			rt		tCode			priority							
destinationID														rCode																	
quadlet data																															

Quadlet-Transmit Format (Read Response)

Figure 7–1. Quadlet Transmit Formats

**Table 7–1. Quadlet Transmit Format Functions**

FIELD NAME	DESCRIPTION																							
spd	The Spd field indicates the speed at which the current packet is to be sent. 00 = 100 Mbps, 01 = 200 Mbps, 10 = 400 Mbps, and 11 is undefined for this implementation.																							
tLabel	The tLabel field is the transaction label, which is a unique tag for each outstanding transaction between two nodes. This field is used to pair up a response packet with its corresponding request packet.																							
rt	The rt field is the retry code for the current packet: 00 = new, 01 = retry_X, 10 = retryA, and 11 = retryB.																							
tCode	The tCode field is the transaction code for the current packet (see Table 6–10 of the IEEE 1394-1995 standard).																							
priority	The priority field contains the priority level for the current packet. For cable implementation, the value of the bits must be zero (for backplane implementation, see clauses 5.4.1.3 and 5.4.2.1 of the IEEE 1394-1995 standard).																							
destinationID	The destinationID field is the concatenation of the 10-bit bus number and the 6-bit node number that forms the destination node address of the current packet.																							
destination OffsetHigh, destination OffsetLow	The concatenation of these two fields addresses a quadlet in the destination node address space. This address must be quadlet aligned (modulo 4).																							
quadlet data	For write requests and read responses, the quadlet data field holds the data to be transferred. For write responses and read requests, this field is not used and should not be written into the FIFO.																							
rCode	Specifies the result of the read request transaction. The response codes that can be returned to the requesting agent are defined as follows:																							
	<table border="1"> <thead> <tr> <th>Response Code</th> <th>Name</th> <th>Description</th> </tr> </thead> <tbody> <tr> <td>0</td> <td>resp_complete</td> <td>Node successfully completed requested operation</td> </tr> <tr> <td>1–3</td> <td>reserved</td> <td></td> </tr> <tr> <td>4</td> <td>resp_conflict_error</td> <td>Resource conflict detected by responding agent Request may be retried.</td> </tr> <tr> <td>5</td> <td>resp_data_error</td> <td>Hardware error. Data not available</td> </tr> <tr> <td>6</td> <td>resp_type_error</td> <td>Field within request packet header contains unsupported or invalid value.</td> </tr> <tr> <td>7</td> <td>resp_address_error</td> <td>Address location within specified node not accessible</td> </tr> <tr> <td>8-Fh</td> <td>reserved</td> <td></td> </tr> </tbody> </table>	Response Code	Name	Description	0	resp_complete	Node successfully completed requested operation	1–3	reserved		4	resp_conflict_error	Resource conflict detected by responding agent Request may be retried.	5	resp_data_error	Hardware error. Data not available	6	resp_type_error	Field within request packet header contains unsupported or invalid value.	7	resp_address_error	Address location within specified node not accessible	8-Fh	reserved
Response Code	Name	Description																						
0	resp_complete	Node successfully completed requested operation																						
1–3	reserved																							
4	resp_conflict_error	Resource conflict detected by responding agent Request may be retried.																						
5	resp_data_error	Hardware error. Data not available																						
6	resp_type_error	Field within request packet header contains unsupported or invalid value.																						
7	resp_address_error	Address location within specified node not accessible																						
8-Fh	reserved																							

**7.1.2 Block Transmit**

The block-transmit format is shown in Figure 7–2 and is described in Table 7–2. The first quadlet contains packet-control information. The second and third quadlets contain the 64-bit address for write requests and read requests and a 4-bit rCode for read responses. The first 16 bits of the fourth quadlet contain the dataLength field. This is the number of bytes of data in the packet. The remaining 16 bits represent the extended\_tCode field (see Table 6–11 of the IEEE 1394-1995 standard for more information on extended\_tCodes). The block data for a block write request follows the extended\_tCode; no block data is included in a block read request.

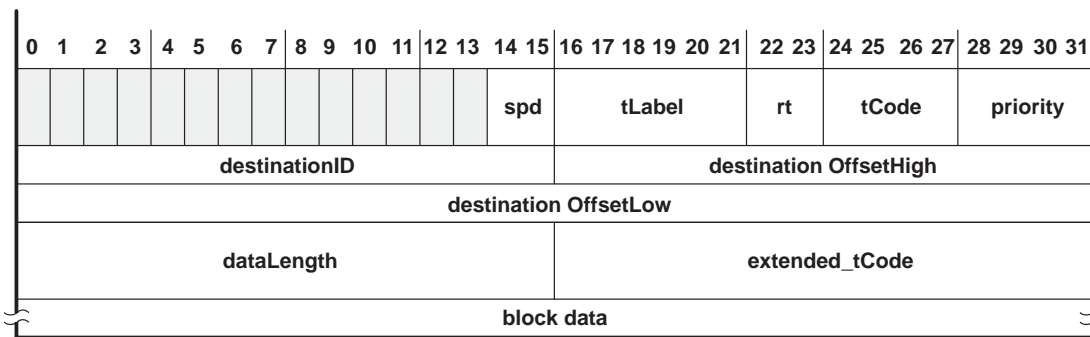

**Figure 7–2. Block Transmit Format**

**Table 7–2. Block Transmit Format Functions**

FIELD NAME	DESCRIPTION
spd	The Spd field indicates the speed at which the current packet is to be sent. 00 = 100 Mbps, 01 = 200 Mbps, and 10 = 400 Mbps, and 11 is undefined for this implementation.
tLabel	The tLabel field is the transaction label, which is a unique tag for each outstanding transaction between two nodes. This field is used to pair up a response packet with its corresponding request packet.
rt	The rt field is the retry code for the current packet: 00 = new, 01 = retry_X, 10 = retryA, and 11 = retryB.
tCode	tCode is the transaction code for the current packet (see Table 6–10 of the IEEE 1394-1995 standard).
priority	The priority level for the current packet. For cable implementation, the value of the bits must be zero. For backplane implementation, see clauses 5.4.1.3 and 5.4.2.1 of the IEEE 1394-1995 standard.
destinationID	The destinationID field is the concatenation of the 10-bit bus number and the 6-bit node number that forms the node address to which the current packet is being sent.
destination OffsetHigh, destination OffsetLow	The concatenation of the destination OffsetHigh and the destination OffsetLow fields addresses a quadlet in the destination node address space. This address must be quadlet aligned (modulo 4). The upper 4 bits of the destination OffsetHigh field are used as the response code for lock-response packets and the remaining bits are reserved.
dataLength	The dataLength field contains the number of bytes of data to be transmitted in the packet.
extended_tCode	The block extended_tCode to be performed on the data in the current packet (see Table 6–11 of the IEEE 1394-1995 standard).
block data	The block data field contains the data to be sent. If dataLength is 0, no data should be written into the FIFO for this field. Regardless of the destination or source alignment of the data, the first byte of the block must appear in byte 0 of the first quadlet.

**7.1.3 Quadlet Receive**

The quadlet-receive format through the FIFO (GRF) is shown in Figure 7–3 and is described in Table 7–3. The first quadlet (trailer) contains the packet-reception status that is added by the TSB12LV32. The first 16 bits of the second quadlet contain the destination node and bus ID, and the remaining 16 bits contain packet-control information. The first 16 bits of the third quadlet contain the node and bus ID of the source, and the remaining 16 bits of the third quadlet and the fourth quadlet contain the 48-bit, quadlet-aligned destination offset address. The last quadlet contains data that is used by write requests and read responses. For read requests and write responses, the quadlet data field is omitted.

The quadlet-receive format through the DM is shown in Figure 7–4 and is described in Table 7–3. This format is similar to the quadlet receive format for the TSB12LV31(GPLynx). The first 16 bits of the first quadlet contain the destination node and bus ID and the remaining 16 bits contain packet-control information. The first 16 bits of the second quadlet contain the node and bus ID of the source, and the remaining 16 bits of the second and third quadlets contain the 48 bit, quadlet-aligned destination offset address for read requests and write requests, but contain the 4-bit rCode for read responses and write responses. The fourth quadlet contains data that is used by write requests and read responses. For read requests and write responses, the quadlet data field is omitted. The last quadlet (trailer) contains the packet-reception status that is added by the TSB12LV32.

0	1	2	3	4	5	6	7	8	9	10	11	12	13	14	15	16	17	18	19	20	21	22	23	24	25	26	27	28	29	30	31
0	0	numofQuadlets										0	0	0	ackCode			0	0	spd		0	0	0	0						
destinationID												tLabel			rt		tCode			priority											
sourceID												destination OffsetHigh																			
destination OffsetLow																															
quadlet data (write requests and read responses only, omitted for write responses and read requests)																															

**Figure 7–3. GRF Quadlet-Receive Format**

0	1	2	3	4	5	6	7	8	9	10	11	12	13	14	15	16	17	18	19	20	21	22	23	24	25	26	27	28	29	30	31
destinationID												tLabel				rt		tCode			priority										
sourceID												destination OffsetHigh																			
destination OffsetLow																															
quadlet data (write requests and read responses only, omitted for write responses and read requests)																															
0	0	numofQuadlets												0	0	0	ackCode			0	0	spd		0	0	0	0				

Figure 7-4. Data-Mover Quadlet-Receive Format

Table 7-3. Quadlet Receive Format Functions

FIELD NAME	DESCRIPTION
numofQuadlets	Total number of quadlets in the current packet (payload and header quadlets only).
ackCode	This 5-bit field holds the acknowledge code sent by the receiver for the current packet (see Table 6-13 in the draft standard).
spd	The Spd field indicates the speed at which the current packet was sent. 00 = 100 Mbps, 01 = 200 Mbps, 10 = 400 Mbps, and 11 is undefined for this implementation.
destinationID	The destinationID field contains the concatenation of the 10-bit bus number and the 6-bit node number that forms the node address to which the current packet is being sent.
tLabel	The tLabel field is the transaction label, which is a unique tag for each outstanding transaction between two nodes. This field is used to pair up a response packet with its corresponding request packet.
rt	The rt field is the retry code for the current packet: 00 = new, 01 = retry_X, 10 = retryA, and 11 = retryB.
tCode	The tCode field is the transaction code for the current packet (see Table 6-10 of the IEEE 1394-1995 standard).
priority	The priority field contains the priority level for the current packet. For cable implementation, the value of the bits must be zero (for backplane implementation, see clauses 5.4.1.3 and 5.4.2.1 of the IEEE 1394-1995 standard).
sourceID	The sourceID field contains the node ID of the sender of the current packet.
destination OffsetHigh, destination OffsetLow	The concatenation of the destination OffsetHigh and the destination OffsetLow fields addresses a quadlet in the destination node address space. This address must be quadlet aligned (modulo 4). (The upper four bits of the destination OffsetHigh field are used as the response code for lock-response packets, and the remaining bits are reserved.)
quadlet data	For write requests and read responses, the quadlet data field holds the transferred data. For write responses and read requests, this field is not present.

### 7.1.4 Block Receive

The block receive format through the GRF is shown in Figure 7–5 and is described in Table 7–4. The first packet contains packet reception status that is added by the TSB12LV32. The first 16 bits of the second quadlet contain the node and bus ID of the destination node, and the last 16 bits contain packet control information. The first 16 bits of the third quadlet contain the node and bus ID of the source node, and the last 16 bits of the third quadlet and all of the fourth quadlet contain the 48-bit, quadlet aligned destination offset address for write requests and read requests, and a 4-bit rCode for read responses. All remaining quadlets contain data that is used only for write requests and read responses. For block read requests, the data field is omitted.

0	1	2	3	4	5	6	7	8	9	10	11	12	13	14	15	16	17	18	19	20	21	22	23	24	25	26	27	28	29	30	31
0	0	numofQuadlets														0	0	0	ackCode			0	0	spd		0	0	0	0		
destinationID																tLabel			rt	tCode		priority									
sourceID																destination OffsetHigh															
destination OffsetLow																															
dataLength																extended_tCode															
block data																															

Figure 7–5. GRF Block-Receive Format

The block receive format through the data mover is shown in Figure 7–6 and is described in Table 7–4. The first 16 bits of the first quadlet contain the node ID and bus ID of the destination node, and the last 16 bits contain packet control information. The first 16 bits of the second quadlet contain the node ID and bus ID of the source node, and the last 16 bits of the second quadlet and all of the third quadlet contain the 48 bit, quadlet aligned destination offset addressfor write requests and read requests, and a 4-bit rCode for read responses. All remaining quadlets, except for the last one, contain data that is used only for write requests and read responses. For block read requests, the data field is omitted. The last quadlet contains packet-reception status.

The block receive format through the data mover is shown in Figure 7–6.

0	1	2	3	4	5	6	7	8	9	10	11	12	13	14	15	16	17	18	19	20	21	22	23	24	25	26	27	28	29	30	31
destinationID																tLabel			rt	tCode		priority									
sourceID																destination OffsetHigh															
destination OffsetLow																															
dataLength																extended_tCode															
block data (if any)																															
0	0	numofQuadlets														0	0	0	ackCode			0	0	spd		0	0	0	0		

Figure 7–6. Data-Mover Block-Receive Format

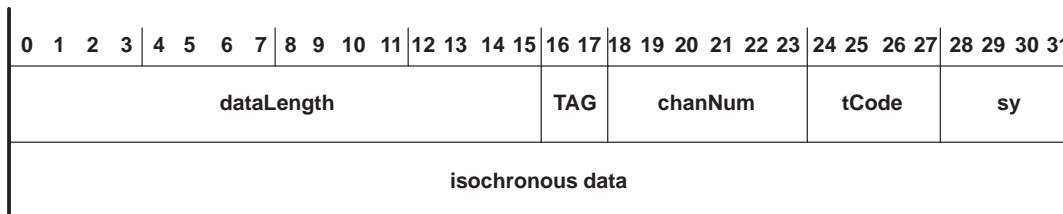

**Table 7–4. Block Receive Format Functions**

FIELD NAME	DESCRIPTION
numofQuadlets	Total number of quadlets in the current packet (payload and header quadlets only)
ackCode	This 5-bit field holds the acknowledge code sent by the receiver for the current packet.
destinationID	The destinationID field is the concatenation of the 10-bit bus number and the 6-bit node number that forms the node address to which the current packet is being sent.
tLabel	The tLabel field is the transaction label, which is a unique tag for each outstanding transaction between two nodes. This field is used to pair up a response packet with its corresponding request packet.
rt	The rt field contains the retry code for the current packet is 00 = new, 01 = retry_X, 10 = retryA, and 11 = retryB.
tCode	The tCode field is the transaction code for the current packet (see Table 6-10 of the IEEE-1394-1995 standard).
priority	The priority field contains the priority level for the current packet. For cable implementation, the value of the bits must be zero (for backplane implementation, see clauses 5.4.1.3 and 5.4.2.1 of the IEEE-1394-1995 standard).
sourceID	The sourceID field contains the node ID of the sender of the current packet.
destination OffsetHigh, destination OffsetLow	The concatenation of the destination OffsetHigh and the destination OffsetLow fields addresses a quadlet in the destination node address space. This address must be quadlet aligned (modulo 4). The upper 4 bits of the destination OffsetHigh field are used as the response code for lock-response packets and the remaining bits are reserved.
dataLength	For write request, read responses, and locks, the dataLength field indicates the number of bytes being transferred. For read requests, the dataLength field indicates the number of bytes of data to be read. A write-response packet does not use this field. Note that the number of bytes does not include the header, only the bytes of data.
extended_tCode	The extended_tCode field contains the block extended_tCode to be performed on the data in the current packet (see Table 6-11 of the IEEE 1394-1995 standard).
block data	The block data field contains any data being transferred for the current packet. Regardless of the destination address or memory alignment, the first byte of the data appears in byte 0 of the first quadlet of this field. The last quadlet of the field is padded with zeros out to four bytes, if necessary.
spd	The spd field indicates the speed at which the current packet was sent. 00 = 100 Mbps, 01 = 200 Mbps, 10 = 400 Mbs, and 11 is undefined for this implementation.

## 7.2 Isochronous Transmit (Data-Mover Port to TSB12LV32)

The format of the isochronous transmit packet is shown in Figure 7–7 and is described in Table 7–5. The data for each channel must be presented to the data-mover port in this format in the order that packets are to be sent. The transmitter sends any packets available at the isochronous transmit interface immediately following reception or transmission of the cycle-start message. The speed at which the current packet is sent is determined by the *speed* field in the DM control register (bits 22–23). There is no FIFO in the TSB12LV32 that supports isochronous transmit.



**Figure 7–7. Isochronous Transmit Format**

**Table 7–5. Isochronous Transmit Functions**

FIELD NAME	DESCRIPTION
dataLength	The dataLength field indicates the number of bytes in the current packet.
TAG	The TAG field indicates the format of data carried by the isochronous packet (00 = formatted, 01–11 are reserved).
chanNum	The chanNum field carries the channel number with which the current data is associated.
tCode	The transaction code for the current packet (tCode = Ah).
sy	The sy field carries the transaction layer-specific synchronization bits.
isochronous data	The isochronous data field contains the data to be sent with the current packet. The first byte of data must appear in byte 0 of the first quadlet of this field. If the last quadlet does not contain four bytes of data, the unused bytes should be padded with zeros.

**7.2.1 Isochronous Receive (TSB12LV32 to Microcontroller Interface/Data-Mover Port)**

The format of the isochronous receive data through the DM is shown in Figure 7–8 and is described in Table 7–6. The data length, which is found in the header of the packet, determines the number of bytes in an isochronous packet. The final packet after the isochronous data contains packet reception information. For isochronous receive through the general receive FIFO, the quadlet containing packet reception information (trailer) is inserted as the first quadlet in the receive data, as shown in Figure 7–8.

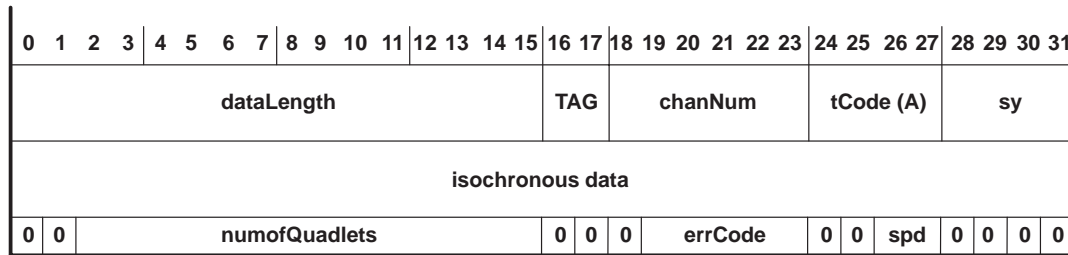

**Figure 7–8. Data-Mover Isochronous Receive Format**

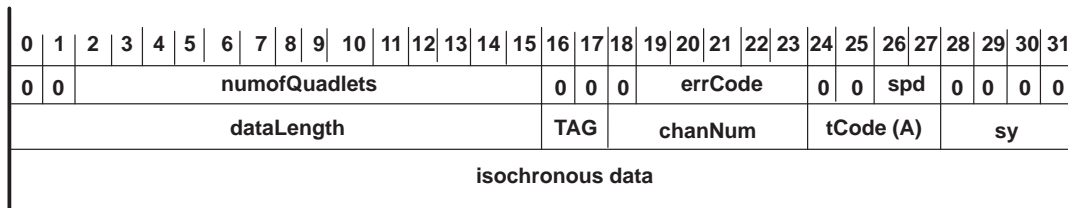

**Figure 7–9. GRF Isochronous Receive Format**

**Table 7–6. Isochronous Receive Functions**

FIELD NAME	DESCRIPTION
dataLength	The dataLength field indicates the number of bytes in the current packet.
TAG	The TAG field indicates the format of data carried by isochronous packet (00 = formatted, 01–11 are reserved).
chanNum	The chanNum field contains the channel number with which this data is associated.
tCode	The tCode field carries the transaction code for the current packet (tCode = Ah).
sy	The sy field carries the transaction layer-specific synchronization bits.
isochronous data	The isochronous data field has the data to be sent with the current packet. The first byte of data must appear in byte 0 of the first quadlet of this field. The last quadlet should be padded with zeros.
spd	The spd field indicates the speed at which the current packet was sent.
numofQuadlets	Total number of quadlets in the current packet (payload and header quadlets only).
errCode	The errCode field indicates whether the current packet has been received correctly. The possibilities are Complete, DataErr, or CRCErr, and have the same encoding as the corresponding acknowledge codes.

### 7.3 Phy Configuration

The format of the Phy configuration packet is shown in Figure 7–10 and is described in Table 7–7. The Phy configuration packet transmit contains two quadlets, which are loaded into the ATF. The first quadlet is written to address 50h. The second quadlet is written to address 58h. The 00E0h in the first quadlet (bits 16–31) tells the TSB12LV32 that this quadlet is the Phy configuration packet. The 00E0h is then replaced with 0000h before the packet is transmitted to the Phy interface.

0	1	2	3	4	5	6	7	8	9	10	11	12	13	14	15	16	17	18	19	20	21	22	23	24	25	26	27	28	29	30	31															
0	0	root_ID						R	T	gap_cnt								tcode = 00E0																												
Logical inverse of first 16 bits of first quadlet																1	1	1	1	1	1	1	1	1	1	1	1	1	1	1	1	1	1	1	1	1	1	1	1	1	1	1	1	1	1	1

Figure 7–10. Phy Configuration Packet Format

The Phy configuration packet can perform the following functions:

- Set the gap count field of all nodes on the bus to a new value. The gap count, if set intelligently, can optimize bus performance.
- Force a particular node to be the bus root after the next bus reset.

It is not valid to transmit a Phy configuration packet with both the R bit and T bit set to zero. This would cause the packet to be interpreted as an extended Phy packet.

Table 7–7. Phy Configuration Packet Functions

FIELD NAME	DESCRIPTION
00	The 00 field is the Phy configuration packet identifier.
root_ID	The root_ID field is the physical_ID of the node to have its force_root bit set (only meaningful when R is set).
R	When R is set, the force-root bit of the node identified in root_ID is set and the force_root bit of all other nodes are cleared. When R is cleared, root_ID is ignored.
T	When T is set, the PHY_CONFIGURATION.gap_count field of all the nodes is set to the value in the gap_cnt field.
gap_cnt	The gap_cnt field contains the new value for PHY_CONFIGURATION.gap_count for all nodes. This value goes into effect immediately upon receipt and remains valid after the next bus reset. After the second reset, gap_cnt is set to 63h unless a new Phy configuration packet is received.

The format of a received Phy-configuration packet is shown in Figure 7–11 and is described in Table 7–8. When PHY\_PKT\_ENA (bit 3 of the control register at 08h) is set, all Phy packets are received in the GRF. One HDRERR interrupt is generated for every Phy packet received.

0	1	2	3	4	5	6	7	8	9	10	11	12	13	14	15	16	17	18	19	20	21	22	23	24	25	26	27	28	29	30	31
0	0	numofQuadlets														0	0	0	ackCode					0	0	spd	0	0	0	0	
Phy configuration quadlet																															
Logical inverse of the Phy configuration quadlet																															

Figure 7–11. Receive Phy Configuration Packet Format

Table 7–8. Receive Phy Configuration Packet

FIELD NAME	DESCRIPTION
numofQuadlets	Total number of quadlets in the packet. This field is equal to 2 in this case.
ackCode	This 5-bit field holds the acknowledge code sent by the receiver for the current packet. In this case, the ackCode is equal to 1 (ack_complete).
spd	The spd field indicates the speed at which the current packet was sent. In this case, the spd field is equal to 00 (S100).

### 7.3.1 Extended Phy Packets

#### 7.3.1.1 Ping Packets

The reception of a Phy ping packet causes the node identified by Phy\_ID to transmit Self-ID packet(s) that reflect the current configuration and status of the Phy. The ping packet provides a method of measuring the round-trip delay of packets between two nodes on the bus that are farthest from one another in terms of cable hops. The format of this packet is shown in Figure 7–12 and described in Table 7–9.

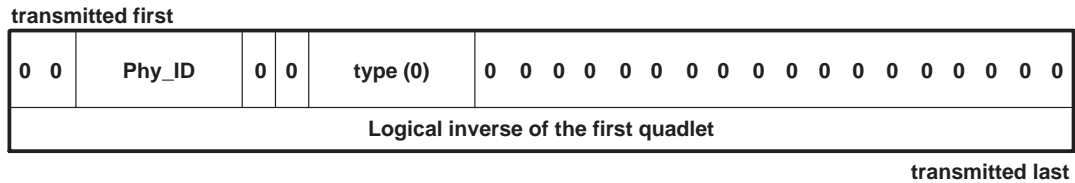

Figure 7–12. Ping Packet Format

Table 7–9. Ping Packet Fields

FIELD NAME	DESCRIPTION
Phy_ID	Physical node identifier of the destination of this packet
type	Extended Phy packet type (zero identifies ping packet)

#### 7.3.1.2 Remote Access Packets

The remote access packet provides a method for a node to access the Phy registers of another node on the bus. The reception of a remote access packet causes the node identified by the Phy\_ID field to read the selected Phy register and subsequently return a remote reply packet that contains the current value of the Phy register. The format of this packet is shown in Figure 7–13 and described in Table 7–10.

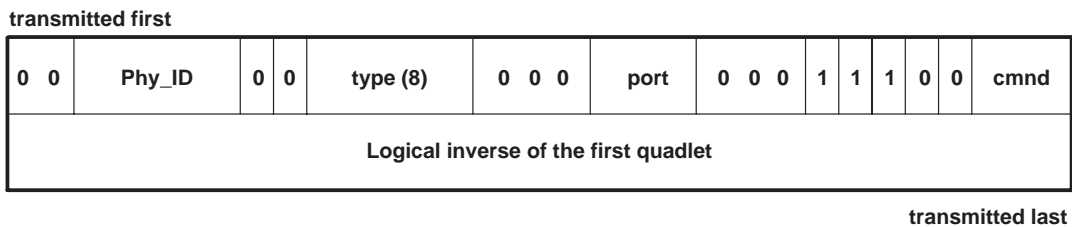

Figure 7–13. Remote Access Packet Format

Table 7–10. Remote Access Packet Fields

FIELD NAME	DESCRIPTION
Phy_ID	Physical node identifier of the destination of this packet
type	Extended Phy packet type (8 identifies command packet)
port	This field selects one of the Phy ports
cmnd	Command: 0 = NOP (No operation) 1 = Transmit TX_DISABLE_NOTIFY, then disable port 2 = Initiate suspend (i.e., become a suspend initiator) 4 = Clear the port's Fault bit to zero 5 = Enable port 6 = Resume port

### 7.3.1.3 Remote Command Packets

The remote command packet provides a method for one node to issue a number of Phy-specific commands to the selected port within the target Phy. The reception of a remote command packet requests the node identified by the `Phy_ID` field to perform the operation specified in the `cmd` field and subsequently return a remote confirmation packet. The format of this packet is shown in Figure 7–14 and described in Table 7–11.

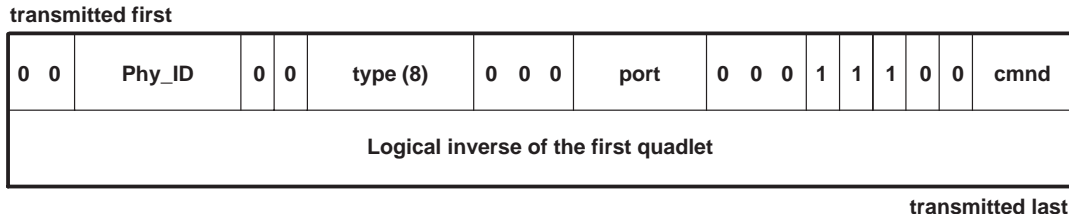

Figure 7–14. Remote Command Packet Format

Table 7–11. Remote Command Packet Fields

FIELD NAME	DESCRIPTION
Phy_ID	Physical node identifier of the destination of this packet
type	Extended Phy packet type (8 identifies command packet)
port	This field selects one of the Phy ports
cmd	Command: 0 = NOP (No operation) 1 = Transmit TX_DISABLE_NOTIFY, then disable port 2 = Initiate suspend (i.e., become a suspend initiator) 4 = Clear the port's Fault bit to zero 5 = Enable port 6 = Resume port

### 7.3.1.4 Resume Packets

The resume packet is a broadcast packet to all the Phys on the bus. It commands all suspended ports on the bus to resume normal operation. The reception of the resume packet causes any node to commence resume operations for all Phy ports that are both connected and suspended. A resume packet requires no reply. The format of this packet is shown in Figure 7–15 and described in Table 7–12.

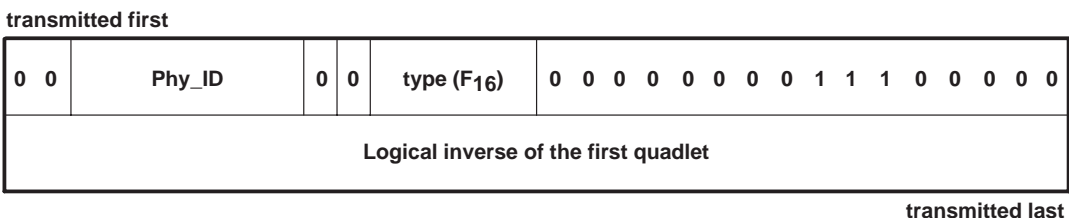

Figure 7–15. Resume Packet Format

Table 7–12. Resume Packet Fields

FIELD NAME	DESCRIPTION
Phy_ID	Physical node identifier of the source of this packet
type	Extended Phy packet type (F identifies resume packet)

### 7.4 Receive Self-ID Packet

Based on the settings of the RXSID and FULLSID bits in the control register at 08h, the self-ID packets can be either ignored or received into the GRF. See Table 7–13.

**Table 7–13. GRF Receive Self-ID Setup Using Control Register Bits (RXSID and FULLSID)**

RXSID (bit 1)	FULLSID (bit 2)	OPERATION
0	X	Self-ID packets are not received by the link.
1	0	Only the data quadlet (first quadlet) of the self-ID packets is received into the GRF.
1	1	Both the data quadlet (first quadlet) and the logical inverse quadlet (second quadlet) of all self-ID packets are received into the GRF.

Figure 7–16 and Figure 7–17 show the format of a received self-ID packet. For completeness, the figures assume the cable Phy on the bus implements the maximum number of ports allowed by the 1394a-2000 specification (16). Both figures show one received self-ID packet. The contents are described in Table 7–14.

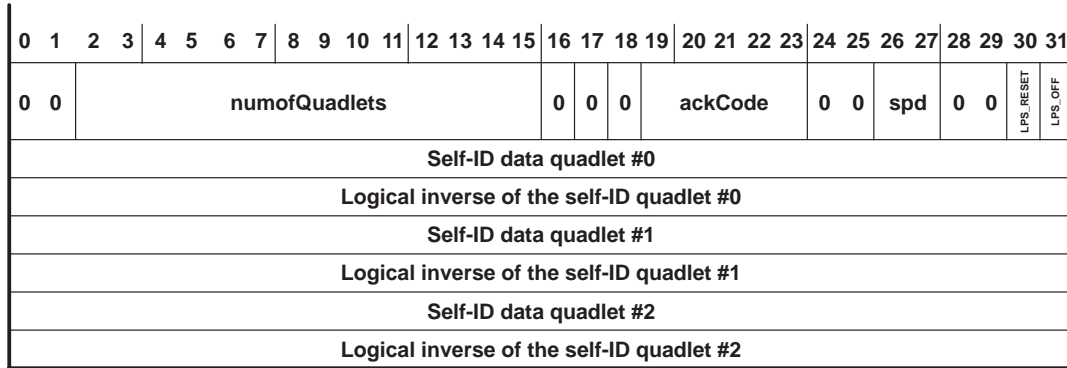

**Figure 7–16. Receive Self-ID Packet Format (RXSID = 1, FULLSID = 1)**

Figure 7–17 shows the format of the received self-ID packet when the FULLSID is cleared. In this case, only the first quadlet of each self-ID packet is received in the GRF.

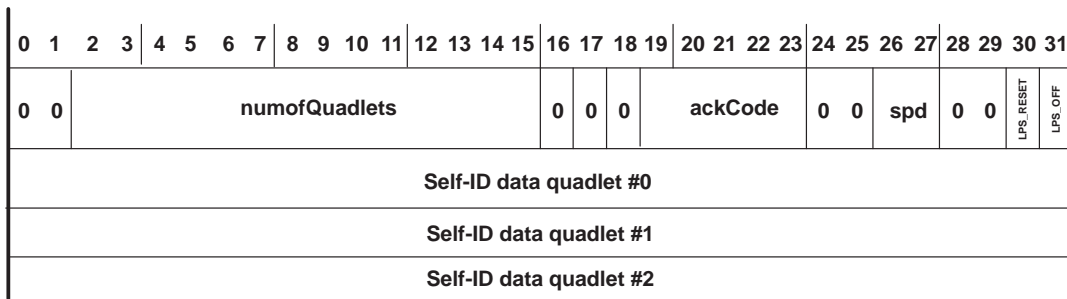

**Figure 7–17. Receive Self-ID Packet Format (RXSID = 1, FULLSID = 0)**

**Table 7–14. Receive Self-ID Function**

FIELD NAME	DESCRIPTION
Self-ID data quadlet	First 32-bits of the first self-ID packet
Logical inverse of the self-ID quadlet	Second 32-bits of the first self-ID packet
ACK	When the ACK field is set (0001), the data in the self-ID packet is correct. When ACK is not equal to 0001, the data in the self-ID packet is incorrect.

The cable Phy sends one to three self-ID packets at the base rate (100 Mbps) during the self-ID phase of arbitration or in response to a ping packet. The number of self-ID packets sent depends on the number of ports. Figure 7–18, Figure 7–19, and Figure 7–20 show the format of the cable Phy self-ID packets. Inside the GRF, the first received quadlet of a self-ID packet is always the header quadlet shown first in Figure 7–17 or Figure 7–18.

0	1	2	3	4	5	6	7	8	9	10	11	12	13	14	15	16	17	18	19	20	21	22	23	24	25	26	27	28	29	30	31
1	0	Phy_ID						0	L	gap_cnt				sp	rsv	c	pwr	p0	p1	p2	i	m									
Logical inverse of first quadlet																															

Figure 7–18. Phy Self-ID Packet #0 Format

0	1	2	3	4	5	6	7	8	9	10	11	12	13	14	15	16	17	18	19	20	21	22	23	24	25	26	27	28	29	30	31
1	0	Phy_ID						1	n(0)	rsv	p3	p4	p5	p6	p7	p8	p9	p10	r	m											
Logical inverse of first quadlet																															

Figure 7–19. Phy Self-ID Packet #1 Format

0	1	2	3	4	5	6	7	8	9	10	11	12	13	14	15	16	17	18	19	20	21	22	23	24	25	26	27	28	29	30	31
1	0	Phy_ID						1	n(1)	rsv	p11	p12	p13	p14	p15	reserved															
Logical inverse of first quadlet																															

Figure 7–20. Phy Self-ID Packet #2 Format

When there is only one node (i.e., one Phy/link pair) on the bus, following a bus reset, the GRF contains only the header quadlet.

**Example:** If there are three 1394a-2000 compliant nodes on the bus, each with a Phy containing three or fewer ports, the GRF of any one of the links is shown below. The FULLSID bit is assumed to be set in this example.

GRF CONTENTS	DESCRIPTION
Header	Header quadlet for self-ID Phy packet
Self-ID1	Self_ID quadlet for Phy #1
Self-ID1 (inverse)	Logical inverse quadlet for self_ID of Phy #1
Self-ID2	Self_ID quadlet for Phy #2
Self-ID2 (inverse)	Logical inverse quadlet for self_ID of Phy #2
Self-ID3	Self_ID quadlet for Phy #3
Self-ID3 (inverse)	Logical inverse quadlet for self_ID of Phy #3
0000_0000_ACK	Trailing acknowledgement quadlet

GRF contents (following a bus reset) with three nodes on the bus

Table 7–15. Phy Self-ID Packet Fields

FIELD NAME	DESCRIPTION
10	The 10 field is the self-ID packet identifier.
L	If set, this node has an active link and transaction layers.
gap_cnt	The gap_cnt field contains the current value for the current node PHY_CONFIGURATION.gap_count field.
sp	The sp field contains the Phy speed capability. The code is: 00 98.304 Mbps 01 98.304 Mbps and 196.608 Mbps 10 98.304 Mbps, 196.608 Mbps, and 393.216 Mbps 11 Extended speed capabilities reported in Phy register 3
c	If set and the link_active flag is set, this node is contender for the bus or isochronous resource manager as described in clause 8.4.2 of IEEE Std 1394-1995.
pwr	Power consumption and source characteristics: 000 Node does not need power and does not repeat power. 001 Node is self-powered and provides a minimum of 15 W to the bus. 010 Node is self-powered and provides a minimum of 30 W to the bus. 011 Node is self-powered and provides a minimum of 45 W to the bus. 100 Node may be powered from the bus and is using up to 3 W. No additional power is needed to enable the link <sup>†</sup> . 101 Reserved for future standardization. 110 Node is powered from the bus and is using up to 3 W. An additional 3 W is needed to enable the link <sup>†</sup> . 111 Node is powered from the bus and is using up to 3 W. An additional 7 W is needed to enable the link <sup>†</sup> .
p0–p15	The p0–p15 field indicates the port connection status. The code is: 00 Not present on the current Phy 01 Not connected to any other Phy 10 Connected to the parent node 11 Connected to the child node
i	If set, this node initiated the current bus reset (i.e., it started sending a bus_reset signal before it received one) <sup>‡</sup> .
m	If set, another self-ID packet for this node immediately follows (i.e., if this bit is set and the next Self-ID packet received has a different Phy_ID, the self-ID packet was lost).
n	Extended self-ID packet sequence number
rsv	Reserved and set to all zeros

<sup>†</sup> The link is enabled by the link-on Phy packet described in clause 7.5.2 of the IEEE 1394.a-2000 specification; this packet can also enable application layers.

<sup>‡</sup> There is no way to ensure that exactly one node has this bit set. More than one node can be requesting a bus reset at the same time.





## 8 TSB12LV32/Phy Interface

This section provides an overview of the digital interface between a TSB12LV32 and a physical layer device (Phy). The information that follows can be used as a guide through the process of connecting the TSB12LV32 to a 1394 Phy. The part numbers referenced, the TSB41LV03A and the TSB12LV32, represent the Texas Instruments implementation of the Phy (TSB41LV03A) and link (TSB12LV32) layers of the IEEE 1394-1995 and 1394a-2000 standards.

The specific details of how the TSB41LV03A device operates are not discussed in this document. Only those parts that relate to the TSB12LV32 Phy interface are mentioned.

### 8.1 Principles of Operation

The TSB12LV32 is designed to operate with a Texas Instruments physical-layer device. The following paragraphs describe the operation of the Phy-LLC interface assuming a TSB41LV03A Phy. The TSB41LV03A is an IEEE 1394a-2000 three-port cable transceiver/arbitrator Phy capable of 400-Mbps speeds.

The interface to the Phy consists of the SCLK, CTL0–CTL1, D0–D7, LREQ, LPS, LINKON, and  $\overline{\text{DIRECT}}$  terminals on the TSB12LV32, as shown in Figure 8–1. See *TSB12LV32 (GP2Lynx)/TSB41LV03 Reference Schematic* application report, Texas Instruments literature number SLLA044, for a detailed description of the electrical interface between the TSB12LV32 and TSB41LV03.

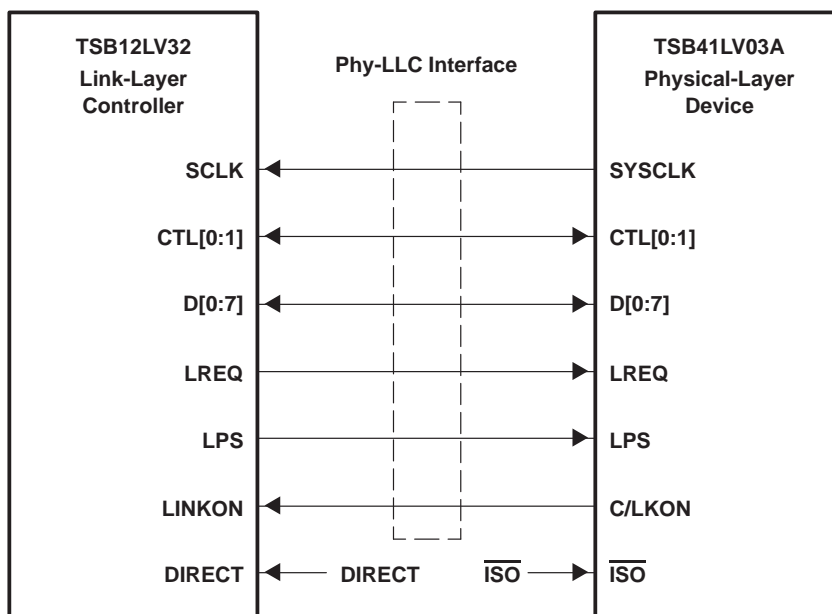

Figure 8–1. Phy-LLC Interface

The SYSCLK from the Phy terminal provides a 49.152-MHz interface clock. All control and data signals are synchronized to, and sampled on, the rising edge of SYSCLK.

The CTL0 and CTL1 terminals form a bidirectional control bus, which controls the flow of information and data between the TSB41LV03A and TSB12LV32.

The D0–D7 terminals form a bidirectional data bus, which is used to transfer status information, control information, or packet data between the devices. The TSB41LV03A supports S100, S200, and S400 data transfers over the D0–D7 data bus. In S100 operation only the D0 and D1 terminals are used; in S200 operation only the D0–D3 terminals are used; and in S400 operation all D0–D7 terminals are used for data transfer. When the TSB41LV03A is in control of the D0–D7 bus, unused Dn terminals are driven low during S100 and S200 operations. When the TSB12LV32 is in control of the D0–D7 bus, unused Dn terminals are ignored by the TSB41LV03A.

The LREQ terminal is controlled by the TSB12LV32 to send serial service requests to the Phy in order to request access to the serial bus for packet transmission, read or write Phy registers, or control arbitration acceleration.

The LPS and LINKON terminals are used for power management of the Phy and TSB12LV32. The LPS terminal indicates the power status of the TSB12LV32, and can be used to reset the Phy-LLC interface or to disable SYSCLK. The C/LKON terminal is used to send a wake-up notification to the TSB12LV32 and to indicate an interrupt to the TSB12LV32 when either LPS is inactive or the Phy register LCtrl bit is zero.

The TSB41LV03A normally controls the CTL0–CTL1 and D0–D7 bidirectional buses. The TSB12LV32 is allowed to drive these buses only after the TSB12LV32 has been granted permission to do so by the Phy. There are four operations that can occur on the Phy-LLC interface: link service request, status transfer, data transmit, and data receive. The TSB12LV32 issues a service request to read or write a Phy register, to request the Phy to gain control of the serial bus in order to transmit a packet, or to control arbitration acceleration.

The Phy can initiate a status transfer either autonomously or in response to a register read request from the TSB12LV32. The Phy initiates a receive operation whenever a packet is received from the serial bus. The Phy initiates a transmit operation after winning control of the serial bus following a bus request by the TSB12LV32. The transmit operation is initiated when the Phy grants control of the interface to the TSB12LV32.

The encoding of the CTL0–CTL1 bus is shown in Table 8–1 and Table 8–2.

**Table 8–1. CTL Encoding When the Phy Has Control of the Bus**

CTL0	CTL1	NAME	DESCRIPTION
0	0	Idle	No activity (this is the default mode)
0	1	Status	Status information is being sent from the Phy to the TSB12LV32.
1	0	Receive	An incoming packet is being sent from the Phy to the TSB12LV32.
1	1	Grant	The TSB12LV32 has been given control of the bus to send an outgoing packet.

**Table 8–2. CTL Encoding When the TSB12LV32 Has Control of the Bus**

CTL0	CTL1	NAME	DESCRIPTION
0	0	Idle	The TSB12LV32 releases the bus (transmission has been completed).
0	1	Hold	The TSB12LV32 is holding the bus while data is being prepared for transmission, or indicating that another packet is to be transmitted (concatenated) without arbitrating.
1	0	Transmit	An outgoing packet is being sent from the TSB12LV32 to the Phy.
1	1	Reserved	Reserved

## 8.2 TSB12LV32 Service Request

To request access to the bus, to read or write a Phy register, or to control arbitration acceleration, the TSB12LV32 sends a serial bit stream on the LREQ terminal as shown in Figure 8–2.



NOTE: Each cell represents one clock sample time, and n is the number of bits in the request stream.

**Figure 8–2. LREQ Request Stream**

The length of the stream varies depending on the type of request as shown in Table 8–3.

**Table 8–3. Request Stream Bit Length**

REQUEST TYPE	NUMBER OF BITS
Bus request	7 or 8
Read register request	9
Write register request	17
Acceleration control request	6

Regardless of the type of request, a start bit of 1 is required at the beginning of the stream, and a stop bit of 0 is required at the end of the stream. The second through fourth bits of the request stream indicate the type of the request. In the descriptions below, bit 0 is the most significant and is transmitted first in the request bit stream. The LREQ terminal is normally low.

Encoding for the request type is shown in Table 8–4.

**Table 8–4. Request Type Encoding**

LR1–LR3	NAME	DESCRIPTION
000	ImmReq	Immediate bus request. Upon detection of idle, the Phy takes control of the bus immediately without arbitration.
001	IsoReq	Isochronous bus request. Upon detection of idle, the Phy arbitrates for the bus without waiting for a subaction gap.
010	PriReq	Priority bus request. The Phy arbitrates for the bus after a subaction gap, ignores the fair protocol.
011	FairReq	Fair bus request. The Phy arbitrates for the bus after a subaction gap, follows the fair protocol.
100	RdReg	The Phy returns the specified register contents through a status transfer.
101	WrReg	Write to the specified register
110	AccelCtl	Enable or disable asynchronous arbitration acceleration
111	Reserved	Reserved

For a bus request the length of the LREQ bit stream is 7 or 8 bits as shown in Table 8–5.

**Table 8–5. Bus Request**

BIT(S)	NAME	DESCRIPTION
0	Start bit	Indicates the beginning of the transfer (always 1)
1–3	Request type	Indicates the type of bus request (see Table 8–4)
4–6	Request speed	Indicates the speed at which the Phy sends the data for this request (see Table 8–6) for the encoding of this field.
7	Stop bit	Indicates the end of the transfer (always 0). If bit 6 is 0, this bit can be omitted.

The 3-bit request speed field used in bus requests is shown in Table 8–6.

**Table 8–6. Bus Request Speed Encoding**

LR4–LR6	DATA RATE
000	S100
010	S200
100	S400
All others	Invalid

**NOTE:** The TSB41LV03A accepts a bus request with an invalid speed code and process the bus request normally. However, during packet transmission for such a request, the TSB41LV03A ignores any data presented by the TSB12LV32 and transmits a null packet.

For a read register request the length of the LREQ bit stream is 9 bits as shown in Table 8–7.

**Table 8–7. Read Register Request**

BIT(S)	NAME	DESCRIPTION
0	Start bit	Indicates the beginning of the transfer (always 1)
1–3	Request type	A 100 indicating this is a read register request.
4–7	Address	Identifies the address of the Phy register to be read
8	Stop bit	Indicates the end of the transfer (always 0)

For a write register request the length of the LREQ bit stream is 17 bits as shown in Table 8–8.

**Table 8–8. Write Register Request**

BIT(S)	NAME	DESCRIPTION
0	Start bit	Indicates the beginning of the transfer (always 1)
1–3	Request type	A 101 indicating this is a write register request
4–7	Address	Identifies the address of the Phy register to be written to
8–15	Data	Gives the data that is to be written to the specified register address
16	Stop bit	Indicates the end of the transfer (always 0)

For an acceleration control request the length of the LREQ bit stream is 6 bits as shown in Table 8–9.

**Table 8–9. Acceleration Control Request**

BIT(S)	NAME	DESCRIPTION
0	Start bit	Indicates the beginning of the transfer (always 1)
1–3	Request type	A 110 indicating this is a acceleration control request
4	Control	Asynchronous period arbitration acceleration is enabled if 1, and disabled if 0.
5	StopBit	Indicates the end of the transfer (always 0)

For fair or priority access, the TSB12LV32 sends the bus request (FairReq or PriReq) at least one clock after the Phy-LLC interface becomes idle. If the CTL terminals are asserted to the receive state (10b) by the Phy, then any pending fair or priority request is lost (cleared). Additionally, the Phy ignores any fair or priority requests if the receive state is asserted while the TSB12LV32 is sending the request. The TSB12LV32 can then reissue the request one clock after the next interface idle.

The cycle master node uses a priority bus request (PriReq) to send a cycle start message. After receiving or transmitting a cycle start message, the TSB12LV32 can issue an isochronous bus request (IsoReq). The Phy clears an isochronous request only when the serial bus has been won.

To send an acknowledge packet, the TSB12LV32 must issue an immediate bus request (ImmReq) during the reception of the packet addressed to it. This is required in order to minimize the idle gap between the end of the received packet and the start of the transmitted acknowledge packet. As soon as the receive packet ends, the Phy immediately grants control of the bus to the TSB12LV32. The TSB12LV32 sends an acknowledgment to the sender unless the header CRC of the received packet is corrupted. In this case, the TSB12LV32 does not transmit an acknowledge, but instead cancels the transmit operation and releases the interface immediately; the TSB12LV32 must not use this grant to send another type of packet. After the interface is released the TSB12LV32 can proceed with another request.

The TSB12LV32 can make only one bus request at a time. Once the TSB12LV32 issues any request for bus access (ImmReq, IsoReq, FairReq, or PriReq), it cannot issue another bus request until the Phy indicates that the bus request was lost (bus arbitration lost and another packet received), or won (bus arbitration won and the TSB12LV32 granted control). The Phy ignores new bus requests while a previous bus request is pending. All bus requests are cleared upon a bus reset.

For write register requests, the Phy loads the specified data into the addressed register as soon as the request transfer is complete. For read register requests, the Phy returns the contents of the addressed register to the TSB12LV32 at the next opportunity through a status transfer. If a received packet interrupts the status transfer, then the Phy continues to attempt the transfer of the requested register until it is successful. A write or read register request can be made at any time, including while a bus request is pending. Once a read register request is made, the Phy ignores further read register requests until the register contents are successfully transferred to the TSB12LV32. A bus reset does not clear a pending read register request.

The TSB41LV03A includes several arbitration acceleration enhancements, which allow the Phy to improve bus performance and throughput by reducing the number and length of interpacket gaps. These enhancements include autonomous (fly-by) isochronous packet concatenation, autonomous fair and priority packet concatenation onto acknowledge packets, and accelerated fair and priority request arbitration following acknowledge packets. The enhancements are enabled when the EAA bit in Phy register 5 is set.

The arbitration acceleration enhancements can interfere with the ability of the cycle master node to transmit the cycle start message under certain circumstances. The acceleration control request is therefore provided to allow the TSB12LV32 to temporarily enable or disable the arbitration acceleration enhancements of the TSB41LV03A during the asynchronous period. The TSB12LV32 typically disables the enhancements when its internal cycle counter rolls over indicating that a cycle start message is imminent, and then re-enables the enhancements when it receives a cycle start message. The acceleration control request can be made at any time, however, and is immediately serviced by the Phy. Additionally, a bus reset or isochronous bus request causes the enhancements to be re-enabled, if the EAA bit is set.

### 8.3 Status Transfer

A status transfer is initiated by the Phy when there is status information to be transferred to the TSB12LV32. The Phy waits until the interface is idle before starting the transfer. The transfer is initiated by the Phy asserting status (01b) on the CTL terminals, along with the first two bits of status information on the D[0:1] terminals. The Phy maintains CTL = status for the duration of the status transfer. The Phy can prematurely end a status transfer by asserting something other than status on the CTL terminals. This occurs if a packet is received before the status transfer completes. The Phy continues to attempt to complete the transfer until all status information has been successfully transmitted. There is at least one idle cycle between consecutive status transfers.

The Phy normally sends just the first four bits of status to the TSB12LV32. These bits are status flags that are needed by the TSB12LV32 state machines. The Phy sends an entire 16-bit status packet to the TSB12LV32 after a read register request, or when the Phy has pertinent information to send to the TSB12LV32 or transaction layers. The only defined condition where the Phy automatically sends a register to the TSB12LV32 is after self-ID, when the Phy sends the physical-ID register that contains the new node address. All status transfers are either 4 or 16 bits unless interrupted by a received packet. The status flags are considered to have been successfully transmitted to the TSB12LV32 immediately upon being sent, even if a received packet subsequently interrupts the status transfer. Register contents are considered to have been successfully transmitted only when all 8 bits of the register have been sent. A status transfer is retried after being interrupted only if any status flags remain to be sent, or if a register transfer has not yet completed.

The definition of the bits in the status transfer are shown in Table 8–10 and the timing is shown in Figure 8–3.

**Table 8–10. Status Bits**

BIT(S)	NAME	DESCRIPTION
0	Arbitration reset gap	Indicates that the Phy has detected that the bus has been idle for an arbitration reset gap time (as defined in IEEE Std 1394–1995). This bit is used by the TSB12LV32 in the busy/retry state machine.
1	Subaction gap	Indicates that the Phy has detected that the bus has been idle for a subaction gap time (as defined in IEEE Std 1394–1995). This bit is used by the TSB12LV32 to detect the completion of an isochronous cycle.
2	Bus reset	Indicates that the Phy has entered the start of the bus reset state.
3	Interrupt	Indicates that a Phy interrupt event has occurred. An interrupt event can be a configuration time-out, cable-power voltage falling too low, a state time-out, or a port status change.
4–7	Address	This field holds the address of the Phy register whose contents are being transferred to the TSB12LV32.
8–15	Data	This field holds the register contents.

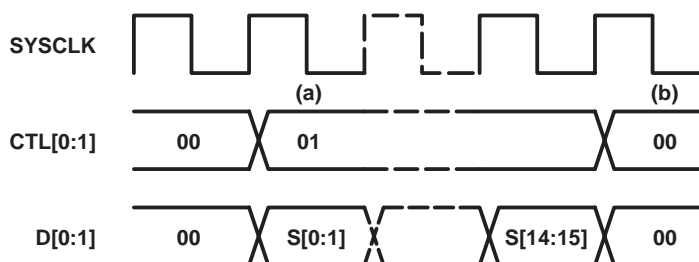

**Figure 8–3. Status Transfer Timing**

The sequence of events for a status transfer is as follows:

- Status transfer initiated. The Phy indicates a status transfer by asserting status on the CTL lines along with the status data on the D0 and D1 lines (only 2 bits of status are transferred per cycle). Normally (unless interrupted by a receive operation), a status transfer is either 2 or 8 cycles long. A 2-cycle (4-bit) transfer occurs when only status information is to be sent. An 8-cycle (16-bit) transfer occurs when register data is to be sent in addition to any status information.
- Status transfer terminated. The Phy normally terminates a status transfer by asserting idle on the CTL lines. The Phy can also interrupt a status transfer at any cycle by asserting receive on the CTL lines to begin a receive operation. The Phy shall assert at least one cycle of idle between consecutive status transfers.

### 8.4 Receive Operation

Whenever the Phy detects the data-prefix state on the serial bus, it initiates a receive operation by asserting receive on the CTL terminals and a logic 1 on each of the D terminals (data-on indication). The Phy indicates the start of a packet by placing the speed code (encoded as shown in Table 8–11 on the D terminals, followed by packet data. The Phy holds the CTL terminals in the receive state until the last symbol of the packet has been transferred. The Phy indicates the end of packet data by asserting idle on the CTL terminals. All received packets are transferred to the TSB12LV32. Note that the speed code is part of the Phy-LLC protocol and is not included in the calculation of CRC or any other data protection mechanisms.

It is possible for the Phy to receive a null packet, which consists of the data-prefix state on the serial bus followed by the data-end state, without any packet data. A null packet is transmitted whenever the packet speed exceeds the capability of the receiving Phy, or whenever the TSB12LV32 immediately releases the bus without transmitting any data. In this case, the Phy asserts receive on the CTL terminals with the data-on indication (all 1s) on the D terminals, followed by idle on the CTL terminals, without any speed code or data being transferred. In all cases, the TSB41LV03A sends at least one data-on indication before sending the speed code or terminating the receive operation.

The TSB41LV03A also transfers its own self-ID packet, transmitted during the self-ID phase of bus initialization, to the TSB12LV32. This packet is transferred to the TSB12LV32 just as any other received self-ID packet.

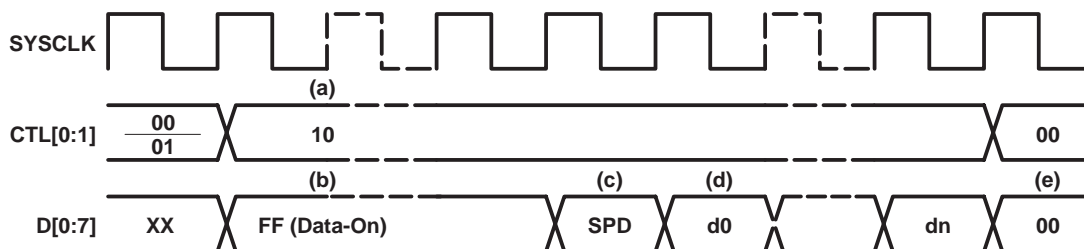

Figure 8–4. Normal Packet Reception Timing

The sequence of events for a normal packet reception is as follows:

- Receive operation initiated. The Phy indicates a receive operation by asserting receive on the CTL lines. Normally, the interface is idle when receive is asserted. However, the receive operation can interrupt a status transfer operation that is in progress so that the CTL lines can change from status to receive without an intervening idle.
- Data-on indication. The Phy asserts the data-on indication code on the D lines for one or more cycles preceding the speed-code.
- Speed-code. The Phy indicates the speed of the received packet by asserting a speed-code on the D lines for one cycle immediately preceding packet data. The link decodes the speed-code on the first receive cycle for which the D lines are not the data-on code. If the speed-code is invalid, or indicates a speed higher than that which the link is capable of handling, the link ignores the subsequent data.

- Receive data. Following the data-on indication (if any) and the speed-code, the Phy asserts packet data on the D lines with receive on the CTL lines for the remainder of the receive operation.
- Receive operation terminated. The Phy terminates the receive operation by asserting idle on the CTL lines. The Phy asserts at least one cycle of idle following a receive operation.

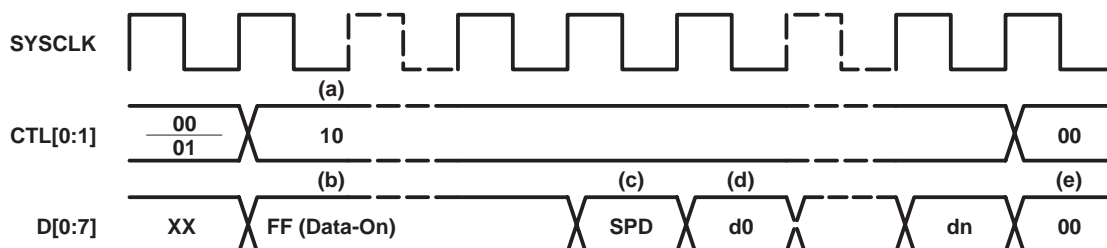

Figure 8–5. Null Packet Reception Timing

The sequence of events for a null packet reception is as follows:

- Receive operation initiated. The Phy indicates a receive operation by asserting receive on the CTL lines. Normally, the interface is idle when receive is asserted. However, the receive operation can interrupt a status transfer operation that is in progress so that the CTL lines can change from status to receive without an intervening idle.
- Data-on indication. The Phy asserts the data-on indication code on the D lines for one or more cycles.
- Receive operation terminated. The Phy terminates the receive operation by asserting idle on the CTL lines. The Phy asserts at least one cycle of idle following a receive operation.

Table 8–11. Receive Speed Codes

D0–D7	DATA RATE
00XX XXXX	S100
0100 XXXX	S200
0101 0000	S400
1YYY YYYY	Data-on indication

NOTE: X = Output as 0 by Phy, ignored by TSB12LV32  
 Y = Output as 1 by Phy, ignored by TSB12LV3

## 8.5 Transmit Operation

When the TSB12LV32 issues a bus request through the LREQ terminal, the Phy arbitrates to gain control of the bus. If the Phy wins arbitration for the serial bus, the Phy-LLC interface bus is granted to the TSB12LV32 by asserting the grant state (11b) on the CTL terminals for one SYSCLK cycle, followed by idle for one clock cycle. The TSB12LV32 then takes control of the bus by asserting either idle (00b), hold (01b), or transmit (10b) on the CTL terminals. Unless the TSB12LV32 immediately releases the interface, the TSB12LV32 can assert the idle state for at most one clock before it must assert either hold or transmit on the CTL terminals. The hold state is used by the TSB12LV32 to retain control of the bus while it prepares data for transmission. The TSB12LV32 can assert hold for zero or more clock cycles (i.e., the TSB12LV32 need not assert hold before transmit). The Phy asserts data-prefix on the serial bus during this time.

When the TSB12LV32 is ready to send data, the TSB12LV32 asserts transmit on the CTL terminals as well as sending the first bits of packet data on the D lines. The transmit state is held on the CTL terminals until the last bits of data have been sent. The TSB12LV32 then asserts either hold or idle on the CTL terminals for one clock cycle, and then asserts idle for one additional cycle before releasing the interface bus and placing its CTL and D terminals in high impedance. The Phy then regains control of the interface bus.



The hold state asserted at the end of packet transmission indicates to the Phy that the TSB12LV32 requests to send another packet (concatenated packet) without releasing the serial bus. The Phy responds to this concatenation request by waiting the required minimum packet separation time and then asserting grant as before. This function can be used to send a unified response after sending an acknowledge, or to send consecutive isochronous packets during a single isochronous period. Unless multispeed concatenation is enabled, all packets transmitted during a single bus ownership must be of the same speed (because the speed of the packets is set before the first packet). If multispeed concatenation is enabled (when the EMSC bit of Phy register 5 is set), the TSB12LV32 must specify the speed code of the next concatenated packet on the D terminals when it asserts hold on the CTL terminals at the end of a packet. The encoding for this speed code is the same as the speed code that precedes received packet data as given in Table 8–11.

After sending the last packet for the current bus ownership, the TSB12LV32 releases the bus by asserting idle on the CTL terminals for two clock cycles. The Phy begins asserting idle on the CTL terminals one clock after sampling idle from the link. Note that whenever the D and CTL terminals change direction between the Phy and the TSB12LV32, there is an extra clock period allowed so that both sides of the interface can operate on registered versions of the interface signals.

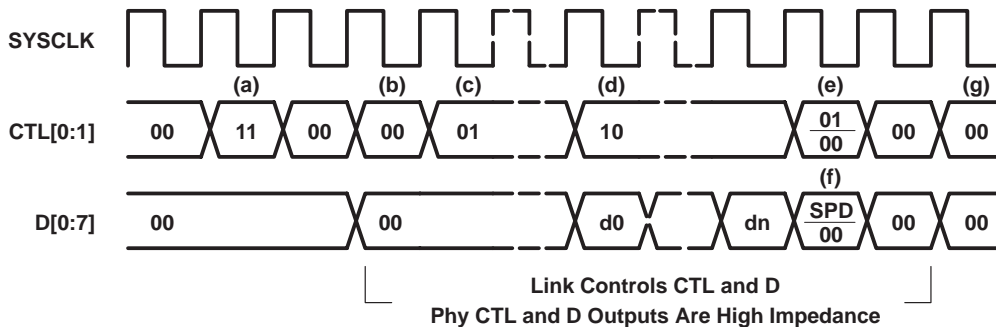

NOTE: SPD = Speed code, see Table 8–11, d0–dn = Packet data

**Figure 8–6. Normal Packet Transmission Timing**

The sequence of events for a normal packet transmission is as follows:

- Transmit operation initiated. The Phy asserts grant on the CTL lines followed by idle to hand over control of the interface to the link so that the link can transmit a packet. The Phy releases control of the interface (i.e., it places its CTL and D outputs in a high-impedance state) following the idle cycle.
- Optional idle cycle. The link can assert at most one idle cycle preceding assertion of either hold or transmit. This idle cycle is optional; the link is not required to assert idle preceding either hold or transmit.
- Optional hold cycles. The link can assert hold for up to 47 cycles preceding assertion of transmit. These hold cycle(s) are optional; the link is not required to assert hold preceding transmit.

### 8.6 TSB12LV32/Phy Interface Critical Timing

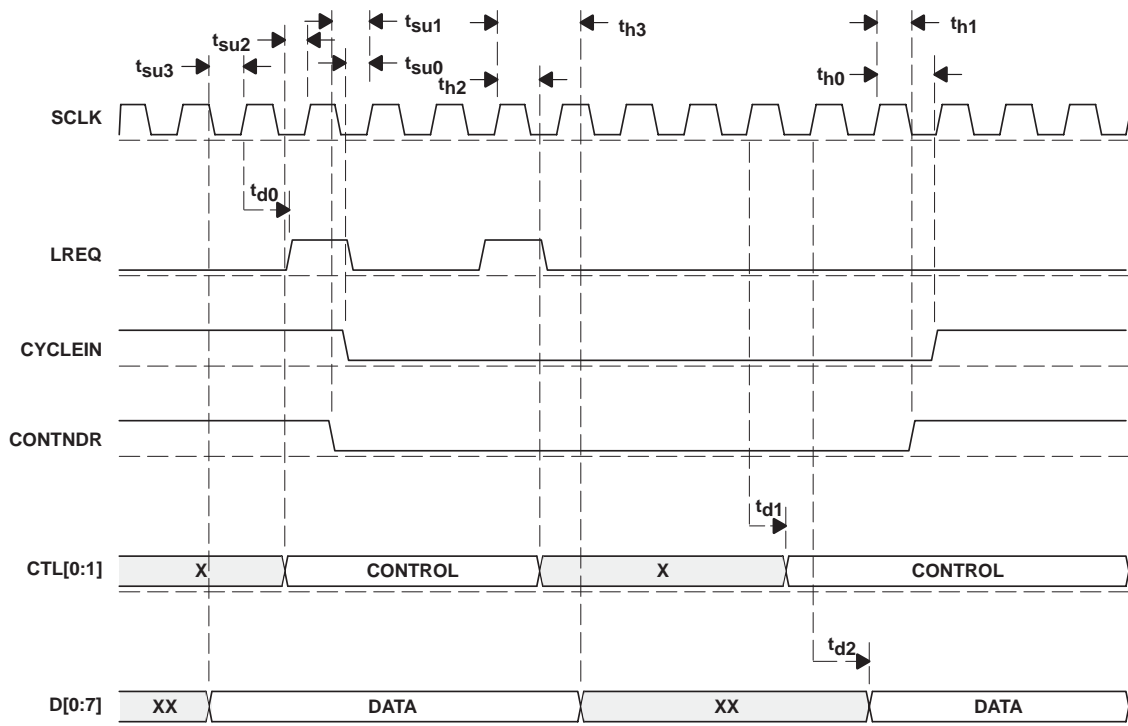

Figure 8–7. Critical Timing for the TSB12LV32/Phy Interface

Table 8–12. TSB12LV32/Phy Interface Timing

PARAMETER†		TERMINAL NAME	MIN	MAX	UNIT
$t_{d0}$	Delay time (SCLK to Q)	LREQ	3	9.5	ns
$t_{d1}$		CTL[0:1]	3	9.5	ns
$t_{d2}$		D[0:7]	3.5	9	ns
$t_{su0}$	Setup time to SCLK	CYCLEIN	2		ns
$t_{su1}$		CONTNDR	3		ns
$t_{su2}$		CTL[0:1]	3		ns
$t_{su3}$		D[0:7]	3		ns
$t_{h0}$	Hold time from SCLK	CYCLEIN	2		ns
$t_{h1}$		CONTNDR	2		ns
$t_{h2}$		CTL[0:1]	0		ns
$t_{h3}$		D[0:7]	0		ns

† All timing parameters are referenced to the rising edge of SCLK on the TSB12LV32 side.



## 9 Electrical Characteristics

### 9.1 Absolute Maximum Ratings Over Operating Free-Air Temperature Range (Unless Otherwise Noted)<sup>†</sup>

Supply voltage range, $V_{CC}$ .....	-0.5 V to 3.6 V
Supply voltage range, $V_{CC5V}$ .....	-0.5 V to 5.5 V
Input voltage range, $V_I$ .....	-0.5 V to $V_{CC5V} + 0.5$ V
Output voltage range, $V_O$ .....	-0.5 V to $V_{CC5V} + 0.5$ V
Input clamp current, $I_{IK}$ ( $V_I < 0$ or $V_I > V_{CC}$ ) <sup>(1)</sup> .....	±20 mA
Output clamp current, $I_{OK}$ ( $V_O < 0$ or $V_O > V_{CC}$ ) <sup>(2)</sup> .....	±20 mA
Operating free-air temperature range .....	-40°C to 110°C
Storage temperature range .....	-65°C to 150°C

<sup>†</sup> Stresses beyond those listed under “absolute maximum ratings” may cause permanent damage to the device. These are stress ratings only, and functional operation of the device at these or any other conditions beyond those indicated under “recommended operating conditions” is not implied. Exposure to absolute-maximum-rated conditions for extended periods may affect device reliability.

NOTES: 1. This applies to external input and bidirectional buffers. For 5-V tolerant terminals, use  $V_I > V_{CC5V}$ .

2. This applies to external output and bidirectional buffers. For 5-V tolerant terminals, use  $V_I > V_{CC5V}$ .

DISSIPATION RATING TABLE

PACKAGE	$T_A \leq 25^\circ\text{C}$ POWER RATING	DERATING FACTOR ABOVE $T_A = 25^\circ\text{C}$	$T_A = 70^\circ\text{C}$ POWER RATING	$T_A = 85^\circ\text{C}$ POWER RATING	$T_A = 110^\circ\text{C}$ POWER RATING
PZ	1500 mW	16.9 mW/°C	739.5 mW	486 mW	63.5 mW

### 9.2 Recommended Operating Conditions

	MIN	NOM	MAX	UNIT
Supply voltage, $V_{CC}$	3	3.3	3.6	V
Supply voltage, $V_{CC5V}$	3	4.5	5.5	V
Input voltage, $V_I$	0		$V_{CC5V}$	V
Output voltage, $V_O$ <sup>†</sup>	0		$V_{CC}$	V
High-level input voltage, $V_{IH}$	2.2		$V_{CC5V}$	V
Low-level input voltage, $V_{IL}$	0		0.7	V
Input transition time, $t_f$ and $t_r$ (10% to 90%)	0		25	ns
Operating free-air temperature, $T_A$	-40	25	110	°C

<sup>†</sup> This applies to external output buffers.

### 9.3 Electrical Characteristics Over Recommended Ranges of Supply Voltage and Operating Free-Air Temperature (Unless Otherwise Noted)

PARAMETER		TEST CONDITIONS	MIN	TYP†	MAX	UNIT
V <sub>OH</sub>	High-level output voltage	I <sub>OH</sub> = -8 mA	V <sub>CC</sub> -0.6			V
V <sub>OL</sub>	Low-level output voltage	I <sub>OL</sub> = 8 mA			0.5	V
I <sub>IL</sub>	Low-level input current	V <sub>I</sub> = V <sub>IL</sub>			-20	μA
I <sub>IH</sub>	High-level input current	V <sub>I</sub> = V <sub>IH</sub>			20	μA
I <sub>OZ</sub>	High-impedance output current	V <sub>O</sub> = V <sub>CC</sub> or GND			±20	μA
I <sub>CC(Q)</sub>	Static supply current	I <sub>O</sub> = 0		10		μA

† All typical characteristics are measured at V<sub>CC</sub> = 3.3 V and T<sub>A</sub> = 25°C.

## 10 Mechanical Information

The TSB12LV32 is packaged in a high-performance 100-pin PZ package. The following shows the mechanical dimensions of the PZ package.

**PACKAGING INFORMATION**

Orderable Device	Status <sup>(1)</sup>	Package Type	Package Drawing	Pins	Package Qty	Eco Plan <sup>(2)</sup>	Lead/ Ball Finish	MSL Peak Temp <sup>(3)</sup>	Samples (Requires Login)
TSB12LV32TPZEP	NRND	LQFP	PZ	100	90	Green (RoHS & no Sb/Br)	CU NIPDAU	Level-3-260C-168 HR	
V62/03622-01XE	NRND	LQFP	PZ	100	90	Green (RoHS & no Sb/Br)	CU NIPDAU	Level-3-260C-168 HR	

<sup>(1)</sup> The marketing status values are defined as follows:

**ACTIVE:** Product device recommended for new designs.

**LIFEBUY:** TI has announced that the device will be discontinued, and a lifetime-buy period is in effect.

**NRND:** Not recommended for new designs. Device is in production to support existing customers, but TI does not recommend using this part in a new design.

**PREVIEW:** Device has been announced but is not in production. Samples may or may not be available.

**OBsolete:** TI has discontinued the production of the device.

<sup>(2)</sup> Eco Plan - The planned eco-friendly classification: Pb-Free (RoHS), Pb-Free (RoHS Exempt), or Green (RoHS & no Sb/Br) - please check <http://www.ti.com/productcontent> for the latest availability information and additional product content details.

**TBD:** The Pb-Free/Green conversion plan has not been defined.

**Pb-Free (RoHS):** TI's terms "Lead-Free" or "Pb-Free" mean semiconductor products that are compatible with the current RoHS requirements for all 6 substances, including the requirement that lead not exceed 0.1% by weight in homogeneous materials. Where designed to be soldered at high temperatures, TI Pb-Free products are suitable for use in specified lead-free processes.

**Pb-Free (RoHS Exempt):** This component has a RoHS exemption for either 1) lead-based flip-chip solder bumps used between the die and package, or 2) lead-based die adhesive used between the die and leadframe. The component is otherwise considered Pb-Free (RoHS compatible) as defined above.

**Green (RoHS & no Sb/Br):** TI defines "Green" to mean Pb-Free (RoHS compatible), and free of Bromine (Br) and Antimony (Sb) based flame retardants (Br or Sb do not exceed 0.1% by weight in homogeneous material)

<sup>(3)</sup> MSL, Peak Temp. -- The Moisture Sensitivity Level rating according to the JEDEC industry standard classifications, and peak solder temperature.

**Important Information and Disclaimer:** The information provided on this page represents TI's knowledge and belief as of the date that it is provided. TI bases its knowledge and belief on information provided by third parties, and makes no representation or warranty as to the accuracy of such information. Efforts are underway to better integrate information from third parties. TI has taken and continues to take reasonable steps to provide representative and accurate information but may not have conducted destructive testing or chemical analysis on incoming materials and chemicals. TI and TI suppliers consider certain information to be proprietary, and thus CAS numbers and other limited information may not be available for release.

In no event shall TI's liability arising out of such information exceed the total purchase price of the TI part(s) at issue in this document sold by TI to Customer on an annual basis.

**OTHER QUALIFIED VERSIONS OF TSB12LV32-EP :**

- Catalog: [TSB12LV32](#)

NOTE: Qualified Version Definitions:

- Catalog - TI's standard catalog product



## IMPORTANT NOTICE

Texas Instruments Incorporated and its subsidiaries (TI) reserve the right to make corrections, modifications, enhancements, improvements, and other changes to its products and services at any time and to discontinue any product or service without notice. Customers should obtain the latest relevant information before placing orders and should verify that such information is current and complete. All products are sold subject to TI's terms and conditions of sale supplied at the time of order acknowledgment.

TI warrants performance of its hardware products to the specifications applicable at the time of sale in accordance with TI's standard warranty. Testing and other quality control techniques are used to the extent TI deems necessary to support this warranty. Except where mandated by government requirements, testing of all parameters of each product is not necessarily performed.

TI assumes no liability for applications assistance or customer product design. Customers are responsible for their products and applications using TI components. To minimize the risks associated with customer products and applications, customers should provide adequate design and operating safeguards.

TI does not warrant or represent that any license, either express or implied, is granted under any TI patent right, copyright, mask work right, or other TI intellectual property right relating to any combination, machine, or process in which TI products or services are used. Information published by TI regarding third-party products or services does not constitute a license from TI to use such products or services or a warranty or endorsement thereof. Use of such information may require a license from a third party under the patents or other intellectual property of the third party, or a license from TI under the patents or other intellectual property of TI.

Reproduction of TI information in TI data books or data sheets is permissible only if reproduction is without alteration and is accompanied by all associated warranties, conditions, limitations, and notices. Reproduction of this information with alteration is an unfair and deceptive business practice. TI is not responsible or liable for such altered documentation. Information of third parties may be subject to additional restrictions.

Resale of TI products or services with statements different from or beyond the parameters stated by TI for that product or service voids all express and any implied warranties for the associated TI product or service and is an unfair and deceptive business practice. TI is not responsible or liable for any such statements.

TI products are not authorized for use in safety-critical applications (such as life support) where a failure of the TI product would reasonably be expected to cause severe personal injury or death, unless officers of the parties have executed an agreement specifically governing such use. Buyers represent that they have all necessary expertise in the safety and regulatory ramifications of their applications, and acknowledge and agree that they are solely responsible for all legal, regulatory and safety-related requirements concerning their products and any use of TI products in such safety-critical applications, notwithstanding any applications-related information or support that may be provided by TI. Further, Buyers must fully indemnify TI and its representatives against any damages arising out of the use of TI products in such safety-critical applications.

TI products are neither designed nor intended for use in military/aerospace applications or environments unless the TI products are specifically designated by TI as military-grade or "enhanced plastic." Only products designated by TI as military-grade meet military specifications. Buyers acknowledge and agree that any such use of TI products which TI has not designated as military-grade is solely at the Buyer's risk, and that they are solely responsible for compliance with all legal and regulatory requirements in connection with such use.

TI products are neither designed nor intended for use in automotive applications or environments unless the specific TI products are designated by TI as compliant with ISO/TS 16949 requirements. Buyers acknowledge and agree that, if they use any non-designated products in automotive applications, TI will not be responsible for any failure to meet such requirements.

Following are URLs where you can obtain information on other Texas Instruments products and application solutions:

### Products

Audio	<a href="http://www.ti.com/audio">www.ti.com/audio</a>
Amplifiers	<a href="http://amplifier.ti.com">amplifier.ti.com</a>
Data Converters	<a href="http://dataconverter.ti.com">dataconverter.ti.com</a>
DLP® Products	<a href="http://www.dlp.com">www.dlp.com</a>
DSP	<a href="http://dsp.ti.com">dsp.ti.com</a>
Clocks and Timers	<a href="http://www.ti.com/clocks">www.ti.com/clocks</a>
Interface	<a href="http://interface.ti.com">interface.ti.com</a>
Logic	<a href="http://logic.ti.com">logic.ti.com</a>
Power Mgmt	<a href="http://power.ti.com">power.ti.com</a>
Microcontrollers	<a href="http://microcontroller.ti.com">microcontroller.ti.com</a>
RFID	<a href="http://www.ti-rfid.com">www.ti-rfid.com</a>
RF/IF and ZigBee® Solutions	<a href="http://www.ti.com/lprf">www.ti.com/lprf</a>

### Applications

Communications and Telecom	<a href="http://www.ti.com/communications">www.ti.com/communications</a>
Computers and Peripherals	<a href="http://www.ti.com/computers">www.ti.com/computers</a>
Consumer Electronics	<a href="http://www.ti.com/consumer-apps">www.ti.com/consumer-apps</a>
Energy and Lighting	<a href="http://www.ti.com/energy">www.ti.com/energy</a>
Industrial	<a href="http://www.ti.com/industrial">www.ti.com/industrial</a>
Medical	<a href="http://www.ti.com/medical">www.ti.com/medical</a>
Security	<a href="http://www.ti.com/security">www.ti.com/security</a>
Space, Avionics and Defense	<a href="http://www.ti.com/space-avionics-defense">www.ti.com/space-avionics-defense</a>
Transportation and Automotive	<a href="http://www.ti.com/automotive">www.ti.com/automotive</a>
Video and Imaging	<a href="http://www.ti.com/video">www.ti.com/video</a>
Wireless	<a href="http://www.ti.com/wireless-apps">www.ti.com/wireless-apps</a>

TI E2E Community Home Page

[e2e.ti.com](http://e2e.ti.com)

Mailing Address: Texas Instruments, Post Office Box 655303, Dallas, Texas 75265  
Copyright © 2011, Texas Instruments Incorporated



**Стандарт  
Электрон  
Связь**

Мы молодая и активно развивающаяся компания в области поставок электронных компонентов. Мы поставляем электронные компоненты отечественного и импортного производства напрямую от производителей и с крупнейших складов мира.

Благодаря сотрудничеству с мировыми поставщиками мы осуществляем комплексные и плановые поставки широчайшего спектра электронных компонентов.

Собственная эффективная логистика и склад в обеспечивает надежную поставку продукции в точно указанные сроки по всей России.

Мы осуществляем техническую поддержку нашим клиентам и предпродажную проверку качества продукции. На все поставляемые продукты мы предоставляем гарантию .

Осуществляем поставки продукции под контролем ВП МО РФ на предприятия военно-промышленного комплекса России , а также работаем в рамках 275 ФЗ с открытием отдельных счетов в уполномоченном банке. Система менеджмента качества компании соответствует требованиям ГОСТ ISO 9001.

Минимальные сроки поставки, гибкие цены, неограниченный ассортимент и индивидуальный подход к клиентам являются основой для выстраивания долгосрочного и эффективного сотрудничества с предприятиями радиоэлектронной промышленности, предприятиями ВПК и научно-исследовательскими институтами России.

С нами вы становитесь еще успешнее!

**Наши контакты:**

**Телефон:** +7 812 627 14 35

**Электронная почта:** [sales@st-electron.ru](mailto:sales@st-electron.ru)

**Адрес:** 198099, Санкт-Петербург,  
Промышленная ул, дом № 19, литера Н,  
помещение 100-Н Офис 331