

NATURAL HEADERS					
PART NUMBER	ENG NUMBER	CKT. SIZE	PLATING	DIM "A"	DIM "B"
30070-1232		12	GOLD	1.039	.827
30070-1235		12	TIN	(26.40)	(21.00)
30070-1032		10	GOLD	.874	.661
30070-1035		10	TIN	(22.20)	(16.80)
30070-0832		8	GOLD	.709	.496
30070-0835		8	TIN	(18.00)	(12.60)
30070-0632		6	GOLD	.543	.331
30070-0635		6	TIN	(13.80)	(8.40)
30070-0432		4	GOLD	.378	.165
30070-0435		4	TIN	(9.60)	(4.20)
30070-0232		2	GOLD	.213	
30070-0235		2	TIN	(5.40)	

BLACK HEADERS					
PART NUMBER	ENG NUMBER	CKT. SIZE	PLATING	DIM "A"	DIM "B"
30070-1212		12	GOLD	1.039	.827
30070-1215		12	TIN	(26.40)	(21.00)
30070-1012		10	GOLD	.874	.661
30070-1015		10	TIN	(22.20)	(16.80)
30070-0812		8	GOLD	.709	.496
30070-0815		8	TIN	(18.00)	(12.60)
30070-0612		6	GOLD	.543	.331
30070-0615		6	TIN	(13.80)	(8.40)
15-97-8048	30070-04B1	4	GOLD	.378	.165
15-97-8043	30070-04B3	4	TIN	(9.60)	(4.20)
15-97-8028	30070-02B1	2	GOLD	.213	
15-97-8023	30070-02B3	2	TIN	(5.40)	

NOTES:

- MATERIAL: HOUSING: POLYESTER, UNFILLED, UL94 V-0, COLOR: SEE CHART
TERMINALS: BRASS
- TERMINAL PLATING:
3 OR 5-.000100/(0.00254) MIN, MATTE TIN OVER .000050/(0.00127) MIN, NICKEL
1 OR 2-.000030/(0.00076) MIN, SELECT GOLD AND .000100/(0.00254) MIN, SELECT MATTE TIN OVER .000050/(0.00127) MIN, NICKEL OVERALL
- PRODUCT SPECIFICATION: PS-5556-003
- PACKAGING: BULK PER PK-30070-001
- PART MATES WITH MINI-FIT JR, TPA RECEPTACLE 30067.
- PARTS ARE NOT TO BE MATED OR UNMATED WHILE CIRCUITS ARE LIVE.
- DISCOLORATION ON THE BANDOLIER CARRIER AREA OF THE PIN IS INHERENT TO THE PLATING PROCESS AND IS DUE TO THE MASKING EFFECT OF THE CARRIER. THIS DISCOLORATION IS IN A NON-FUNCTIONAL AREA OF THE PIN AND WILL NOT AFFECT THE PREFORMMANCE OF THE HEADER ASSEMBLY.
- PARTS CONFORM TO CLASS "B" REQUIREMENTS OF COSMETIC SPECIFICATION PS-45499-002.
FORMING MARKS ARE ACCEPTABLE.
- PARTS ARE NOT DESIGNED FOR CURRENT SHARING.

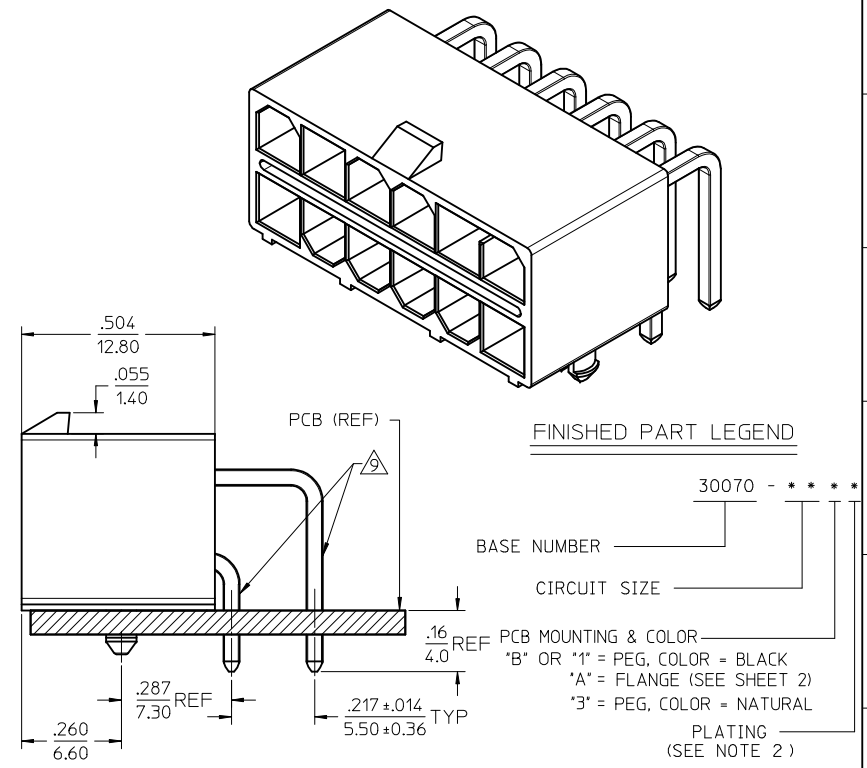
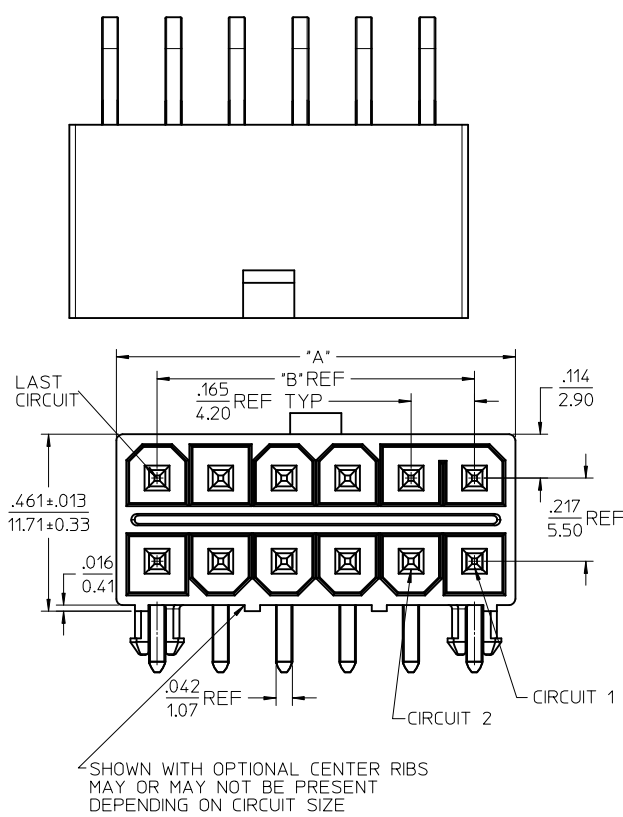

FINISHED PART LEGEND

30070 - * * * *

BASE NUMBER

CIRCUIT SIZE

PCB MOUNTING & COLOR
"B" OR "1" = PEG, COLOR = BLACK
"A" = FLANGE (SEE SHEET 2)
"3" = PEG, COLOR = NATURAL

PLATING (SEE NOTE 2)

SHOWN WITH OPTIONAL CENTER RIBS
MAY OR MAY NOT BE PRESENT
DEPENDING ON CIRCUIT SIZE

**OPTION 1 AND 3
PEG MOUNT**
SEE SHEET 2 FOR FLANGE MOUNT

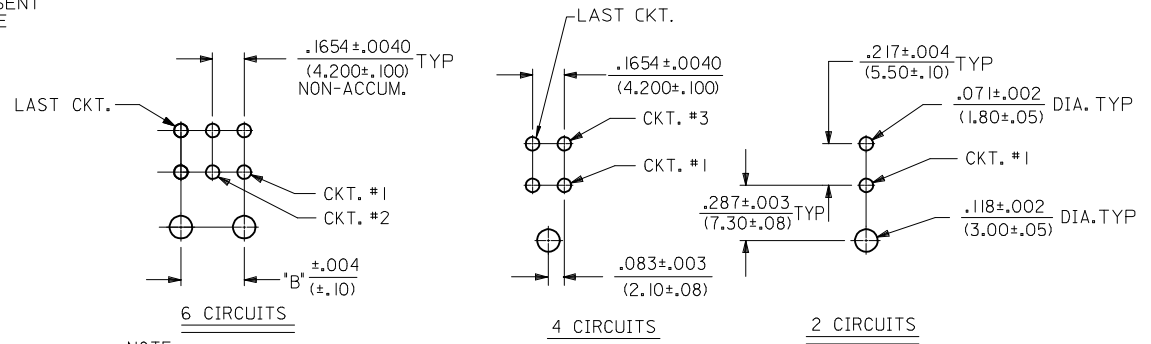

NOTE:
DIMENSIONS SHOWN IN THIS VIEW ARE TYPICAL FOR ALL P.C.B. CONFIGURATIONS FROM 6-16 CIRCUITS.

RECOMMENDED HOLE LAYOUT FOR .070/(1.78) MAX. P.C.BOARD
VIEWED FROM COMPONENT SIDE OF BOARD

OBS P/N'S EC NO: UCP2013-1811 DRWIN:BBEE CHKD:JBELL APPR:FSMITH REV: D1	QUALITY SYMBOLS ▽=0 ▽=0 ▽=0	GENERAL TOLERANCES (UNLESS SPECIFIED)	DIMENSION STYLE IN/MM	SCALE 4:1	DESIGN UNITS METRIC	THIRD ANGLE PROJECTION
		4 PLACES ± --- ± ---	DRAWN BY TGREGORI	DATE 2006/03/28	MINI-FIT TPA RIGHT ANGLE HEADER ASSY	
		3 PLACES ± --- ± .010	CHECKED BY JCOMERCI	DATE 2006/03/28	MOLEX INCORPORATED	
		2 PLACES ± 0.25 ± .014	APPROVED BY FSMITH	DATE 2010/04/09	SD-30070-001	
1 PLACE ± 0.36 ± ---	ANGULAR ± 1/2°	DRAFT WHERE APPLICABLE MUST REMAIN WITHIN DIMENSIONS	SEE TABLE	MATERIAL NO. DOCUMENT NO.	SHEET NO. 1 OF 2	
THIS DRAWING CONTAINS INFORMATION THAT IS PROPRIETARY TO MOLEX INCORPORATED AND SHOULD NOT BE USED WITHOUT WRITTEN PERMISSION						

BLACK FLANGE MOUNT HEADERS

CKT. SIZE	PART NUMBER	ENG NUMBER	PLATING	DIM "A"	DIM "B"	DIM "C"	DIM "D"
2	15-97-8022	30070-02A3	TIN	.213	—	.354	.606
	15-97-8027	30070-02A1	GOLD	(5.40)	—	(9.00)	(15.40)
4	15-97-8042	30070-04A3	TIN	.378	.165	.520	.772
	15-97-8047	30070-04A1	GOLD	(9.60)	(4.20)	(13.20)	(19.60)
6	15-97-8062	30070-06A3	TIN	.543	.331	.685	.937
	15-97-8067	30070-06A1	GOLD	(13.80)	(8.40)	(17.40)	(23.80)
8	15-97-8082	30070-08A3	TIN	.709	.496	.850	1.102
	15-97-8087	30070-08A1	GOLD	(18.00)	(12.60)	(21.60)	(28.00)
10	15-97-8102	30070-10A3	TIN	.874	.661	1.016	1.268
	15-97-8107	30070-10A1	GOLD	(22.20)	(16.80)	(25.80)	(32.20)
12	15-97-8122	30070-12A3	TIN	1.039	.827	1.181	1.433
	15-97-8127	30070-12A1	GOLD	(26.40)	(21.00)	(30.00)	(36.40)
16	15-97-8162	30070-16A3	TIN	1.370	1.157	1.512	1.764
	15-97-8167	30070-16A1	GOLD	(34.80)	(29.40)	(38.40)	(44.80)

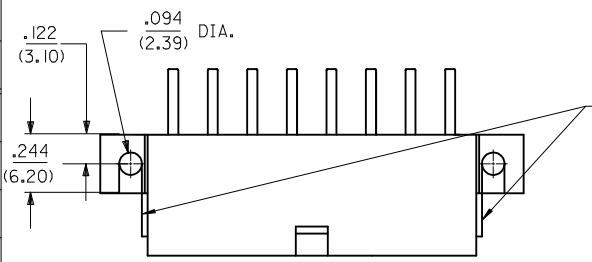

THIS FEATURE IS NOT PRESENT ON 12 AND 16 CIRCUIT PARTS.

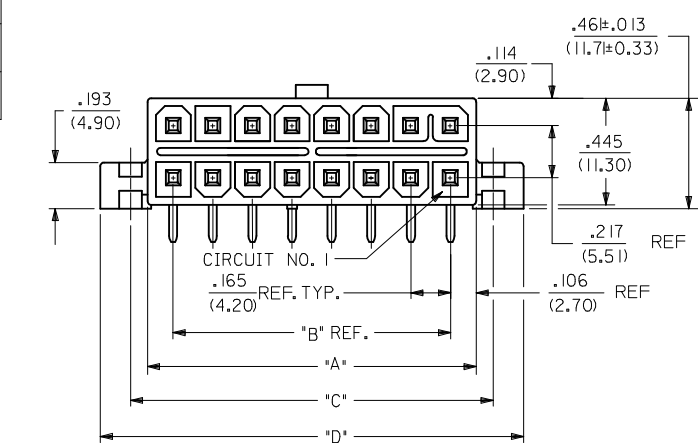

OPTION 2 FLANGE MOUNT

SEE SHEET 1 FOR PEG MOUNT

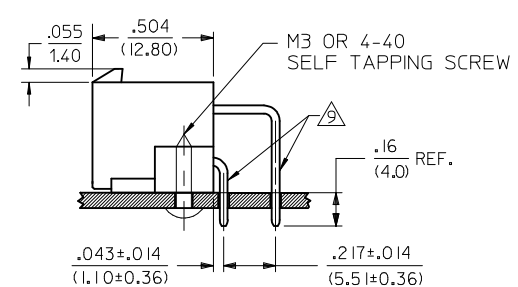

FINISHED PART LEGEND

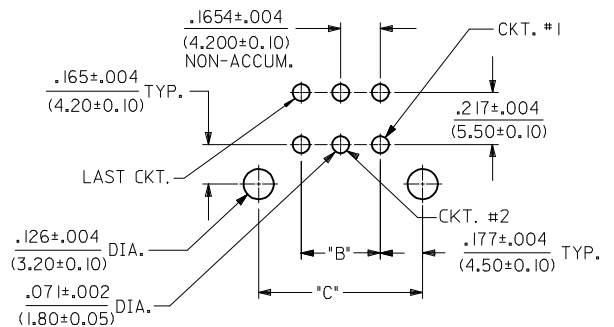
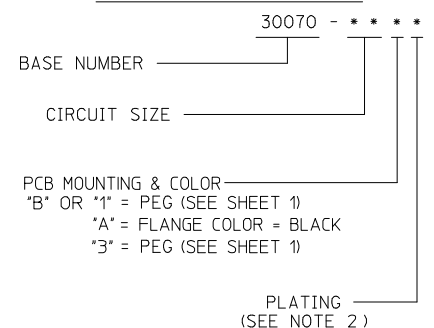

RECOMMENDED HOLE LAYOUT FOR .070/(1.78) MAX. P.C. BOARD
VIEWED FROM COMPONENT SIDE OF BOARD

SEE SHEET 1 EC NO: UCP2013-1811 DRWN:BBEE CHKD:JBELL APPR:FSMITH	REV D1	DESCRIPTION 2012/11/06 2012/11/06 2013/01/11	QUALITY SYMBOLS ▽=0 ▽=0 ▽=0	GENERAL TOLERANCES (UNLESS SPECIFIED)	DIMENSION STYLE IN/MM	SCALE 4:1	DESIGN UNITS METRIC	THIRD ANGLE PROJECTION	
				4 PLACES ± --- ± ---	DRAWN BY TGREGORI	DATE 2006/03/28	MINI-FIT TPA RIGHT ANGLE HEADER ASSY		
				3 PLACES ± --- ± .010	CHECKED BY JCOMERCI	DATE 2006/03/28			
				2 PLACES ± 0.25 ± .014	APPROVED BY FSMITH	DATE 2010/04/09	MOLEX INCORPORATED		
1 PLACE ± 0.36 ± ---	ANGULAR ±1/2°		DRAFT WHERE APPLICABLE MUST REMAIN WITHIN DIMENSIONS		SEE TABLE	MATERIAL NO. DOCUMENT NO. SD-30070-001	SHEET NO. 2 OF 2		
THIS DRAWING CONTAINS INFORMATION THAT IS PROPRIETARY TO MOLEX INCORPORATED AND SHOULD NOT BE USED WITHOUT WRITTEN PERMISSION									



Стандарт Электрон Связь

Мы молодая и активно развивающаяся компания в области поставок электронных компонентов. Мы поставляем электронные компоненты отечественного и импортного производства напрямую от производителей и с крупнейших складов мира.

Благодаря сотрудничеству с мировыми поставщиками мы осуществляем комплексные и плановые поставки широчайшего спектра электронных компонентов.

Собственная эффективная логистика и склад в обеспечивает надежную поставку продукции в точно указанные сроки по всей России.

Мы осуществляем техническую поддержку нашим клиентам и предпродажную проверку качества продукции. На все поставляемые продукты мы предоставляем гарантию .

Осуществляем поставки продукции под контролем ВП МО РФ на предприятия военно-промышленного комплекса России , а также работаем в рамках 275 ФЗ с открытием отдельных счетов в уполномоченном банке. Система менеджмента качества компании соответствует требованиям ГОСТ ISO 9001.

Минимальные сроки поставки, гибкие цены, неограниченный ассортимент и индивидуальный подход к клиентам являются основой для выстраивания долгосрочного и эффективного сотрудничества с предприятиями радиоэлектронной промышленности, предприятиями ВПК и научно-исследовательскими институтами России.

С нами вы становитесь еще успешнее!

Наши контакты:

Телефон: +7 812 627 14 35

Электронная почта: sales@st-electron.ru

Адрес: 198099, Санкт-Петербург,
Промышленная ул, дом № 19, литера Н,
помещение 100-Н Офис 331