

## LM3492HC/LM3492HCQ Two-Channel Individual Dimmable LED Driver with Boost Converter and Fast Current Regulator

Check for Samples: [LM3492HC](#), [LM3492HCQ](#)

### FEATURES

#### Boost Converter:

- **LM3492HCQ is an Automotive Grade Product that is AEC Q100 Grade 1 Qualified**
- **Very Wide Input Voltage Ranged from 4.5V-65V**
- **Programmable Soft-Start**
- **No Loop Compensation Required**
- **Stable with Ceramic and Other Low ESR Capacitors with No Audible Noise**
- **Nearly Constant Switching Frequency Programmable from 200 kHz to 1 MHz**

#### Current Regulators:

- **Programmable LED Current from 50 mA to 250 mA**
- **10000:1 Contrast Ratio, 300 ns Minimum Pulse Width**
- **Two Individual Dimmable LED Strings up to 65V, Total 15W (Typically 28 LEDs @ 150 mA)**
- **Dynamic Headroom Control Maximizes Efficiency**
- **Over-Power Protection**
- **±3% Current Accuracy**

#### Supervisory Functions:

- **Precision Enable**
- **COMM I/O Pin for Diagnostic and Commands**
- **Thermal Shutdown Protection**
- **Thermally Enhanced HTSSOP-20 Package**

### APPLICATIONS

- **Ultra-High Contrast Ratio 6.5"-10" LCD Display Backlight up to 28 LEDs**
- **Automotive or Marine GPS Display**

### DESCRIPTION

The LM3492HC integrates a boost converter and a two-channel current regulator to implement a high efficient and cost effective LED driver for driving two individually dimmable LED strings with a maximum power of 15W and an output voltage of up to 65V. The boost converter employs a proprietary Projected-On-Time control method to give a fast transient response with no compensation required, and a nearly constant switching frequency programmable from 200 kHz to 1 MHz. The application circuit is stable with ceramic capacitors and produces no audible noise on dimming. The programmable peak current limit and soft-start features reduce current surges at startup, and an integrated 190 mΩ, 3.9A N-Channel MOSFET switch minimizes the solution size. The fast slew rate current regulator allows high frequency and narrow pulse width dimming signals to achieve a very high contrast ratio of 10000:1. The LED current is programmable from 50 mA to 250 mA by a single resistor.

To maximize the efficiency, Dynamic Headroom Control (DHC) automatically adjusts the output voltage to a minimum. DHC also facilitates a single BOM for different number of LED in a string, which is required for backlight panels of different size, thereby reducing overall development time and cost. The LM3492HC comes with a versatile COMM pin which serves as a bi-directional I/O pin interfacing with an external MCU for the following functions: power-good, over-temperature, IOUT over- and under-voltage indications, switching frequency tuning, and channel 1 disabling. Other supervisory functions of the LM3492HC include precise enable, VCC under-voltage lock-out, current regulator over-power protection, and thermal shutdown protection. The LM3492HC is available in the thermally enhanced HTSSOP-20 package.



Please be aware that an important notice concerning availability, standard warranty, and use in critical applications of Texas Instruments semiconductor products and disclaimers thereto appears at the end of this data sheet.

All trademarks are the property of their respective owners.

Typical Application

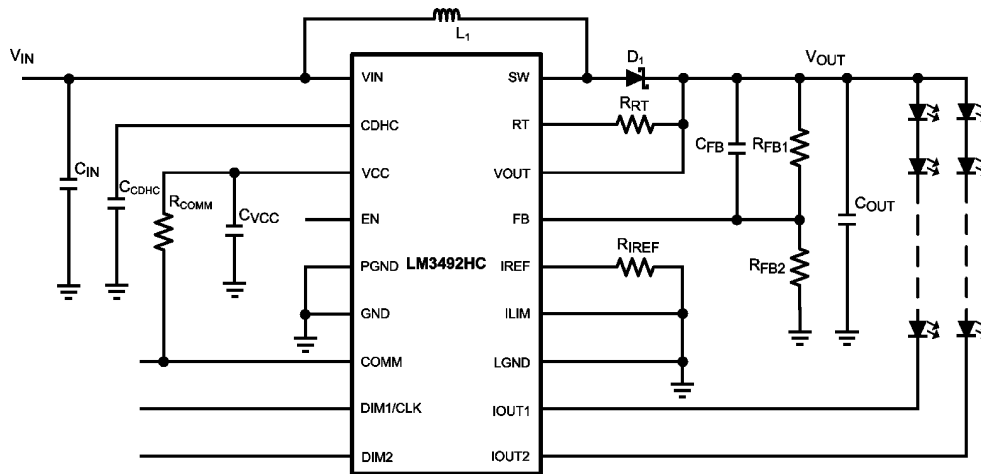

Connection Diagram

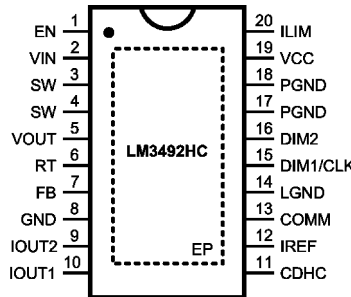

Figure 1. 20-Lead Plastic HTSSOP (PWP0020A) Top View

Pin Descriptions

Pin	Name	Description	Application Information
1	EN	Enable	Internally pull-up. Connect to a voltage higher than 1.63V to provide precision enable for the device.
2	VIN	Input Supply Voltage	Supply pin to the device. Input range is 4.5V to 65V.
3, 4	SW	Switch Node	Internally connected to the drain of the integrated MOSFET.
5	VOUT	Output Voltage Sense	Sense the output voltage for nearly constant switching frequency control.
6	RT	Frequency Control	An external resistor from the VOUT pin to this pin sets the switching frequency.
7	FB	Output Voltage Feedback	The output voltage is connected to this pin through a feedback resistor divider for output voltage regulation. The dynamic range of this pin is from 1.05V to 2.0V.
8	GND	Analog Ground	Signal Ground
9	IOUT2	Current Regulator Input of Channel 2	Input of the current regulator of channel 2. The regulated current is programmable (refer to the IREF pin).
10	IOUT1	Current Regulator Input of Channel 1	Input of the current regulator of channel 1. The regulated current is programmable (refer to the IREF pin).
11	CDHC	Dynamic Headroom Control	An external capacitor connected to this pin sets the DHC sensitivity. At startup, a 120 $\mu$ A internal current source charges an external capacitor to provide a soft-start function.
12	IREF	Current Setting of the Current Regulator	An external resistor connected from this pin to ground programs the regulated current of the current regulator of channels 1 and 2.

### Pin Descriptions (continued)

Pin	Name	Description	Application Information
13	COMM	Bi-directional Logic Communication	This pin is open drain for various indications (power-good, over-temperature, IOUT over- and under-voltage) and command sending (switching frequency tuning and channel 1 disabling).
14	LGND	Ground of the Current Regulator	Current regulator ground. Must be connected to the GND pin for normal operation. The LGND and GND pins are not internally connected.
15	DIM1/CLK	Dimming Control of Channel 1	Control the on/off of the current regulator of channel 1. This pin is internally pulled low by a 5 $\mu$ A current. This pin also serves as a clock signal for latching input/output data of the COMM pin.
16	DIM2	Dimming Control of Channel 2	Control the on/off of the current regulator of channel 2. This pin is internally pulled low by a 5 $\mu$ A current.
17, 18	PGND	Power Ground	Integrated MOSFET ground. Must be connected to the GND pin for normal operation. The PGND and GND pins are not internally connected.
19	VCC	LDO Regulator Output	Nominally regulated to 5.5V. Connect a capacitor of larger than 0.47 $\mu$ F between the VCC and GND pins.
20	ILIM	Peak Current Limit Adjust	Connect an external resistor from the ILIM pin to the VCC pin reduces peak current limit. Connect the ILIM pin to the ground to obtain the maximum current limit.
DAP	DAP	Exposed Pad	Thermal connection pad. Connect to a ground plane.



These devices have limited built-in ESD protection. The leads should be shorted together or the device placed in conductive foam during storage or handling to prevent electrostatic damage to the MOS gates.

### Absolute Maximum Ratings <sup>(1)(2)</sup>

VIN, RT, VOUT to GND		-0.3V to 67V
SW to GND		-0.3V to 67V
SW to GND (Transient)		-2V (<100 ns)
ILIM to GND		-0.3V to 1V
FB to GND		-0.3V to 5V
COMM, DIM1, DIM2, to GND		-0.3V to 6V
ESD Rating <sup>(3)</sup>	Human Body Model	$\pm$ 2kV
Storage Temperature Range		-65°C to +150°C
Junction Temperature (T <sub>J</sub> )		150°C

- (1) Absolute Maximum Ratings are limits which damage to the device may occur. Operating ratings are conditions under which operation of the device is intended to be functional. For ensured specifications and test conditions, see the electrical characteristics. Thermal shutdown might occur within ambient operating temperature range as junction temperature rises above TSD level, customer should refer to efficiency data and thermal resistance data to estimate the junction temperature to ambient temperature delta.
- (2) If Military/Aerospace specified devices are required, please contact the TI Sales Office/ Distributors for availability and specifications.
- (3) The human body model is a 100 pF capacitor discharged through a 1.5 k $\Omega$  resistor into each pin.

### Operating Ratings <sup>(1)</sup>

Supply Voltage (VIN)	4.5V to 65V
Operation Temperature Range (T <sub>A</sub> )	-40°C to +125°C
Thermal Resistance ( $\theta_{JA}$ ) <sup>(2)</sup>	32.7°C/W

- (1) Absolute Maximum Ratings are limits which damage to the device may occur. Operating ratings are conditions under which operation of the device is intended to be functional. For ensured specifications and test conditions, see the electrical characteristics. Thermal shutdown might occur within ambient operating temperature range as junction temperature rises above TSD level, customer should refer to efficiency data and thermal resistance data to estimate the junction temperature to ambient temperature delta.
- (2) The  $\theta_{JA}$  is measured on a 4-layer standard JEDEC thermal test board with 12 vias, no air flow and 1W power dissipation. Thermal shutdown will occur if the junction temperature exceeds 165°C. The maximum power dissipation is a function of T<sub>J(MAX)</sub>,  $\theta_{JA}$  and T<sub>A</sub>. The maximum allowable power dissipation at any ambient temperature is  $PD = (T_{J(MAX)} - T_A) / \theta_{JA}$ .

## Electrical Characteristics

Specification with standard type are for  $T_A = T_J = +25^\circ\text{C}$  only; limits in boldface type apply over the full Operating Junction Temperature ( $T_J$ ) range. Minimum and Maximum are specified through test, design or statistical correlation. Typical values represent the most likely parametric norm at  $T_J = +25^\circ\text{C}$ , and are provided for reference purposes only. Unless otherwise stated the following conditions apply:  $V_{IN} = 12\text{V}$ .

Symbol	Parameter	Conditions	Min	Typ	Max	Units
<b>Start-Up Regulator, VCC</b>						
$V_{CC}$	VCC pin output voltage	$C_{VCC} = 0.47\ \mu\text{F}$ , no load	<b>4.7</b>	5.5	<b>6.3</b>	V
		$I_{CC} = 2\ \text{mA}$	<b>4.7</b>	5.5	<b>6.3</b>	V
$V_{CC-UVLO}$	VCC pin under-voltage lockout threshold (UVLO)	$V_{CC}$ increasing	3.56	3.78	4.00	V
$V_{CC-UVLO-HYS}$	VCC pin UVLO hysteresis	$V_{CC}$ decreasing		310		mV
$I_{IN}$	$I_{IN}$ operating current	No switching, $V_{FB} = 0\text{V}$		3.6	<b>5.2</b>	mA
$I_{IN-SD}$	$I_{IN}$ operating current, Device shutdown	$V_{EN} = 0\text{V}$		30	<b>95</b>	$\mu\text{A}$
$I_{VCC}$	VCC pin current limit <sup>(1)</sup>	$V_{CC} = 0\text{V}$	<b>18</b>	30		mA
$V_{CC-VOUT}$	VCC pin output voltage when supplied by VOUT	$V_{IN} = \text{Open}$ , $I_{CC} = 1\ \text{mA}$ , $V_{OUT} = 18\text{V}$	3.5	4.1	4.7	V
<b>Enable Input</b>						
$V_{EN}$	EN pin input threshold	$V_{EN}$ rising	<b>1.55</b>	1.63	<b>1.71</b>	V
$V_{EN-HYS}$	EN pin threshold hysteresis	$V_{EN}$ falling		194		mV
$I_{EN-SHUT}$	Enable Pull-up Current at shutdown	$V_{EN} = 0\text{V}$		2		$\mu\text{A}$
$I_{EN-OPER}$	Enable Pull-up Current during operation	$V_{EN} = 2\text{V}$		40		$\mu\text{A}$
<b>Current Regulator</b>						
$V_{IREF}$	IREF pin voltage	$V_{IN} = 4.5\text{V}$ to $65\text{V}$	<b>1.231</b>	1.256	<b>1.281</b>	V
$V_{DHC50}$	$V_{IOUT}$ under DHC at $I_{OUT} = 50\ \text{mA}$	$R_{IREF} = 25\ \text{k}\Omega$	<b>0.160</b>	0.225	<b>0.290</b>	V
$V_{DHC100}$	$V_{IOUT}$ under DHC at $I_{OUT} = 100\ \text{mA}$	$R_{IREF} = 12.5\ \text{k}\Omega$	<b>0.38</b>	0.48	<b>0.58</b>	V
$V_{DHC200}$	$V_{IOUT}$ under DHC at $I_{OUT} = 200\ \text{mA}$	$R_{IREF} = 6.25\ \text{k}\Omega$	<b>0.81</b>	0.99	<b>1.17</b>	V
$V_{DHC250}$	$V_{IOUT}$ under DHC at $I_{OUT} = 250\ \text{mA}$	$R_{IREF} = 5\ \text{k}\Omega$	<b>0.81</b>	1.21	<b>1.44</b>	V
$I_{OUT50}$	Current Output under DHC at $V_{IOUT} = V_{DHC50}$	$R_{IREF} = 25\ \text{k}\Omega$ , $V_{IOUT} = V_{DHC50}$	47.5	50	52.5	mA
		$R_{IREF} = 25\ \text{k}\Omega$ , $V_{IOUT} = V_{DHC50}$	<b>46.5</b>	50	<b>53.5</b>	mA
$I_{OUT100}$	Current Output under DHC at $V_{IOUT} = V_{DHC100}$	$R_{IREF} = 12.5\ \text{k}\Omega$ , $V_{IOUT} = V_{DHC100}$	97	100	103	mA
		$R_{IREF} = 12.5\ \text{k}\Omega$ , $V_{IOUT} = V_{DHC100}$	<b>96</b>	100	<b>104</b>	mA
$I_{OUT200}$	Current Output under DHC at $V_{IOUT} = V_{DHC200}$	$R_{IREF} = 6.25\ \text{k}\Omega$ , $V_{IOUT} = V_{DHC200}$	194	200	206	mA
		$R_{IREF} = 6.25\ \text{k}\Omega$ , $V_{IOUT} = V_{DHC200}$	<b>192</b>	200	<b>208</b>	mA
$I_{OUT250}$	Current Output under DHC at $V_{IOUT} = V_{DHC250}$	$R_{IREF} = 5\ \text{k}\Omega$ , $V_{IOUT} = V_{DHC250}$	241.3	250	258.8	mA
		$R_{IREF} = 5\ \text{k}\Omega$ , $V_{IOUT} = V_{DHC250}$	<b>238</b>	250	<b>262</b>	mA
$I_{OUTOFF}$	Leakage at Maximum Work Voltage	$V_{DIM} = 0$ , $V_{IOUT} = 65\text{V}$			5	$\mu\text{A}$
$V_{IOUT50-MIN}$	Minimum Work Voltage, 50 mA	$R_{IREF} = 25\ \text{k}\Omega$ , $I_{OUT} = 0.98 \times I_{OUT50}$		0.1	0.15	V
$V_{IOUT100-MIN}$	Minimum Work Voltage, 100 mA	$R_{IREF} = 12.5\ \text{k}\Omega$ , $I_{OUT} = 0.98 \times I_{OUT100}$		0.2	0.35	V
$V_{IOUT200-MIN}$	Minimum Work Voltage, 200 mA	$R_{IREF} = 6.25\ \text{k}\Omega$ , $I_{OUT} = 0.98 \times I_{OUT200}$		0.4	0.65	V
$V_{IOUT250-MIN}$	Minimum Work Voltage, 250 mA	$R_{IREF} = 5\ \text{k}\Omega$ , $I_{OUT} = 0.98 \times I_{OUT250}$		0.5	0.82	V
$V_{DIM-HIGH}$	DIM Voltage HIGH		<b>1.17</b>			V
$V_{DIM-LOW}$	DIM Voltage LOW				<b>0.7</b>	V
<b>Boost Converter</b>						
$I_{CDHC-SRC}$	CDHC pin source current	$V_{CDHC} = 1.6\text{V}$ , $V_{FB} = 3\text{V}$ , $V_{IOUT} = 0\text{V}$ , DIM = High		60		$\mu\text{A}$
$I_{CDHC-SINK}$	CDHC pin sink current	$V_{CDHC} = 1.6\text{V}$ , $V_{FB} = 3\text{V}$ , $V_{IOUT} = 3\text{V}$ , DIM = High		56		$\mu\text{A}$
$I_{CDHC-PULLUP}$	CDHC pin pull-up current	DIM = Low, $V_{CDHC} = 2.3\text{V}$ , $V_{FB} = 3\text{V}$	<b>10</b>	200	<b>500</b>	nA

(1)  $V_{CC}$  provides self bias for the internal gate drive and control circuits. Device thermal limitations limit external loading.

**Electrical Characteristics (continued)**

Specification with standard type are for  $T_A = T_J = +25^\circ\text{C}$  only; limits in boldface type apply over the full Operating Junction Temperature ( $T_J$ ) range. Minimum and Maximum are specified through test, design or statistical correlation. Typical values represent the most likely parametric norm at  $T_J = +25^\circ\text{C}$ , and are provided for reference purposes only. Unless otherwise stated the following conditions apply:  $V_{IN} = 12\text{V}$ .

Symbol	Parameter	Conditions	Min	Typ	Max	Units
$I_{CL-MAX}$	Integrated MOSFET peak current limit threshold		<b>3.3</b>	3.9	<b>4.5</b>	A
$I_{CL-HALF}$	Half integrated MOSFET peak current limit threshold	$R_{ILIM} = 11\text{ k}\Omega$		2.0		A
$R_{DS(on)}$	Integrated MOSFET $R_{DS(on)}$	$I_{SW} = 500\text{ mA}$		0.19	<b>0.43</b>	$\Omega$
$V_{FBTH-PWRGD}$	Power-Good FB pin threshold			2.25		V
$V_{FB-OVP}$	FB pin over-voltage protection threshold	$V_{FB}$ rising, $V_{CDHC} = 4\text{V}$	<b>2.64</b>	2.76	<b>2.88</b>	V
	FB pin OVP hysteresis	$V_{FB}$ falling	<b>0.1</b>	0.215	<b>0.323</b>	V
$I_{FB}$	Feedback pin input current	$V_{FB} = 3\text{V}$			1	$\mu\text{A}$
$t_{on}$	ON timer pulse width	$V_{IN} = 12\text{V}$ , $V_{OUT} = 65\text{V}$ , $R_{RT} = 300\text{ k}\Omega$		1460		ns
		$V_{IN} = 24\text{V}$ , $V_{OUT} = 32.5\text{V}$ , $R_{RT} = 300\text{ k}\Omega$		800		ns
		$V_{IN} = 12\text{V}$ , $V_{OUT} = 65\text{V}$ , $R_{RT} = 100\text{ k}\Omega$		550		ns
		$V_{IN} = 24\text{V}$ , $V_{OUT} = 32.5\text{V}$ , $R_{RT} = 100\text{ k}\Omega$		350		ns
$t_{on-min-ILIM}$	ON timer minimum pulse width at current limit			145		ns
$t_{off}$	OFF timer pulse width			145	<b>350</b>	ns
<b>COMM PIN</b>						
$V_{IOUT-OV}$	IOUT pin over-voltage threshold	COMM goes LOW during $V_{IOUT}$ rising, other $V_{IOUT} = 1.2\text{V}$	<b>5.6</b>	6.7	<b>7.8</b>	V
$V_{COMM-LOW}$	COMM pin at LOW	5 mA into COMM			0.7	V
$I_{LEAK-FAULT}$	COMM pin Open Leakage	$V_{COMM} = 5\text{V}$			<b>5</b>	$\mu\text{A}$
<b>Thermal Protection</b>						
$T_{OTM}$	Over-temperature indication	$T_J$ rising		135		$^\circ\text{C}$
$T_{OTM-HYS}$	Over-temperature indication hysteresis	$T_J$ falling		15		$^\circ\text{C}$
$T_{SD}$	Thermal shutdown temperature	$T_J$ rising		165		$^\circ\text{C}$
$T_{SD-HYS}$	Thermal shutdown temperature hysteresis	$T_J$ falling		20		$^\circ\text{C}$

### Typical Performance Characteristics

Unless otherwise specified the following conditions apply:  $T_J = 25^\circ\text{C}$ ,  $V_{IN} = 12\text{V}$  with configuration in typical application circuit for  $I_{LED} = 250\text{ mA}$  shown in this datasheet.

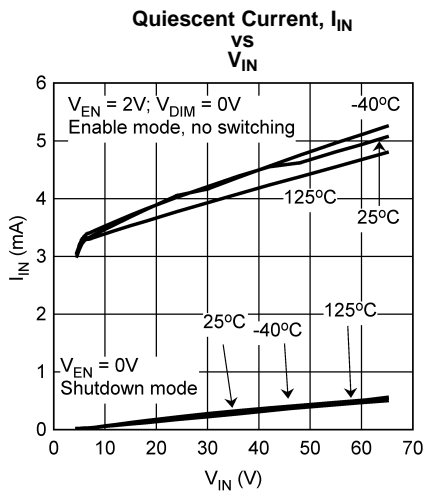

Figure 2.

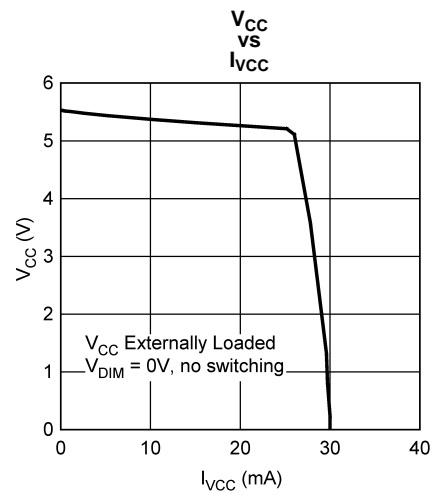

Figure 3.

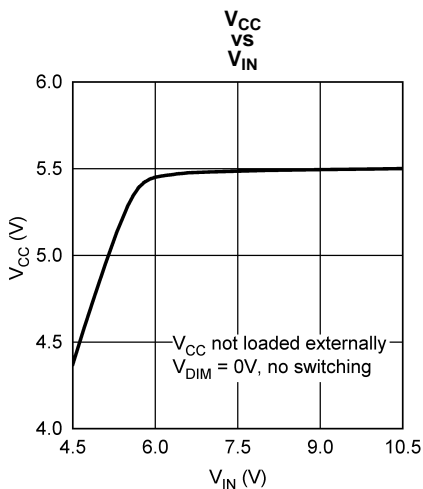

Figure 4.

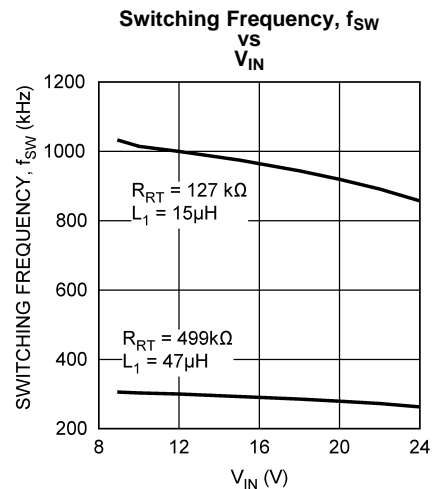

Figure 5.

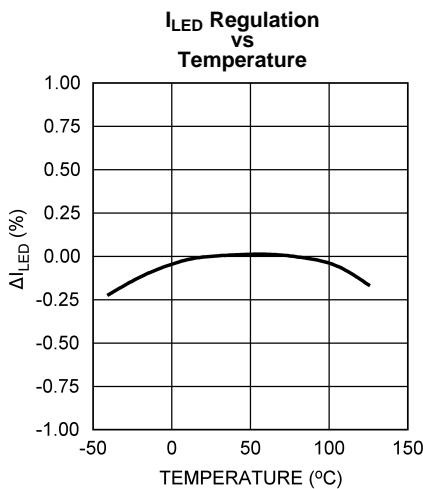

Figure 6.

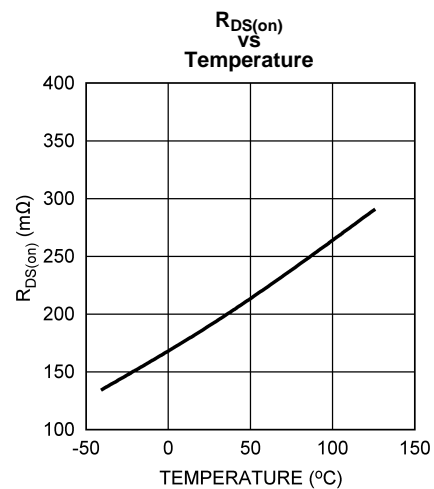

Figure 7.

Typical Performance Characteristics (continued)

Unless otherwise specified the following conditions apply:  $T_J = 25^\circ\text{C}$ ,  $V_{IN} = 12\text{V}$  with configuration in typical application circuit for  $I_{LED} = 250\text{ mA}$  shown in this datasheet.

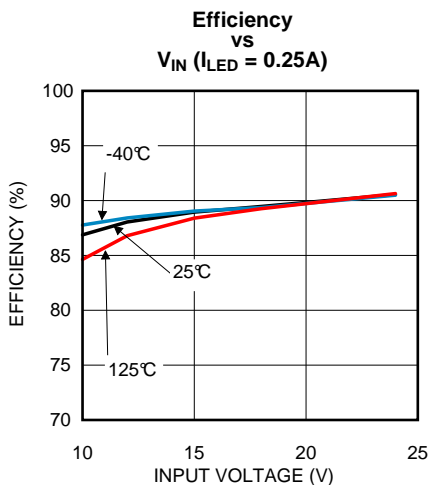

Figure 8.

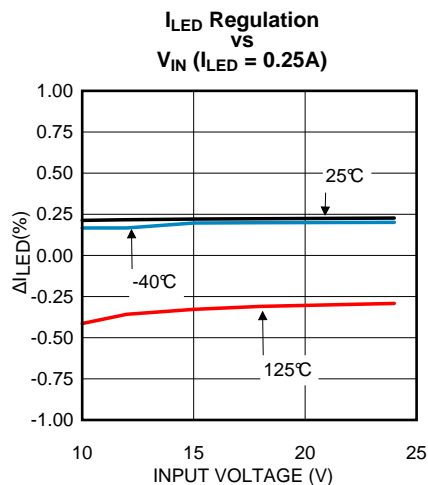

Figure 9.

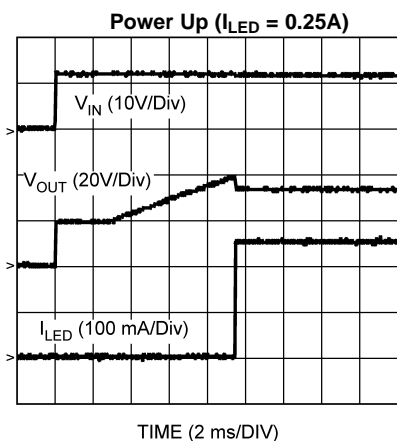

Figure 10.

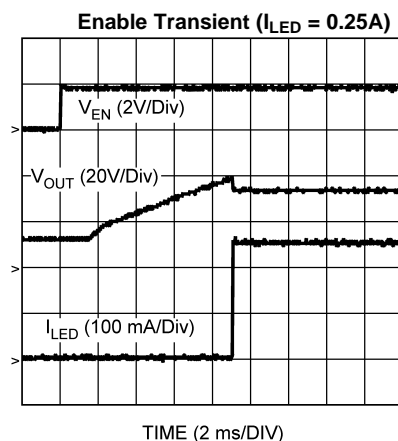

Figure 11.

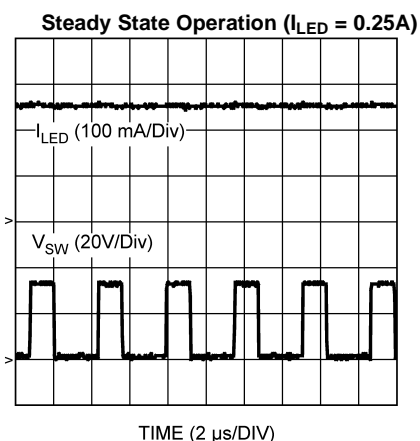

Figure 12.

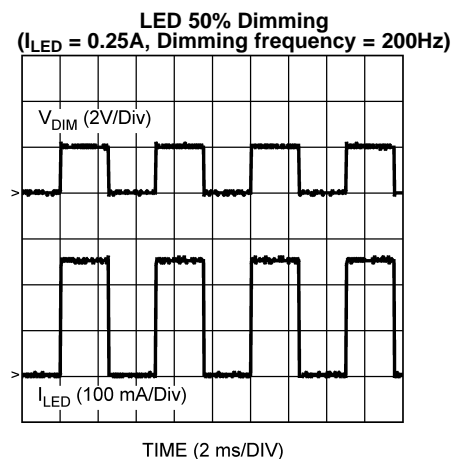
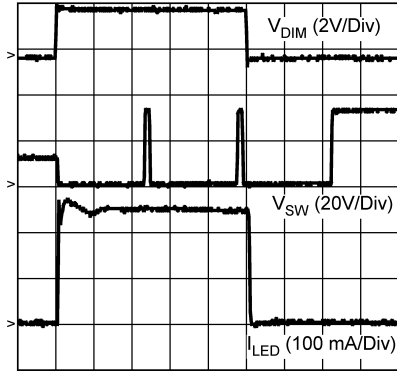

Figure 13.

**Typical Performance Characteristics (continued)**

Unless otherwise specified the following conditions apply:  $T_J = 25^\circ\text{C}$ ,  $V_{IN} = 12\text{V}$  with configuration in typical application circuit for  $I_{LED} = 250\text{ mA}$  shown in this datasheet.

**1000:1 LED Dimming**  
( $I_{LED} = 0.25\text{A}$ , Dimming frequency = 200Hz)



TIME (1  $\mu\text{s}/\text{DIV}$ )  
**Figure 14.**

**10000:1 LED Dimming**  
( $I_{LED} = 0.25\text{A}$ , Dimming frequency = 200Hz)

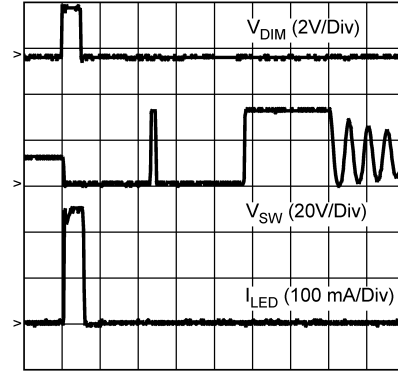

TIME (1  $\mu\text{s}/\text{DIV}$ )  
**Figure 15.**



Simplified Functional Block Diagram

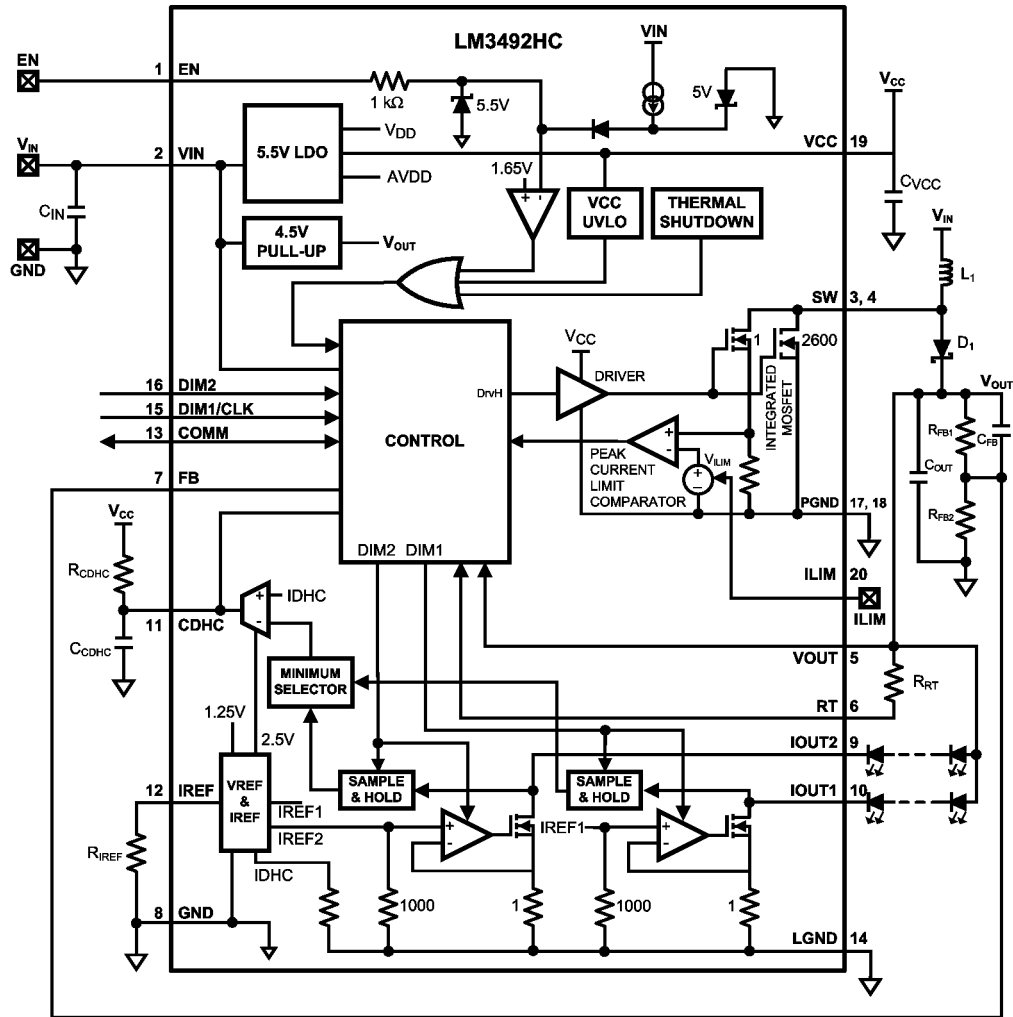

## OVERVIEW

The LM3492HC integrates a boost converter and a two-channel current regulator to implement a high efficient and cost effective LED driver for driving two individually dimmable LED strings with a maximum power of 15W and an output voltage of up to 65V. The boost converter provides power for the LED strings, and the current regulator controls the dimming of the LED strings individually. The LM3492HC integrates an N-channel MOSFET switch and a two-channel current regulator in order to minimize the component count and solution size.

The boost converter of the LM3492HC employs a Projected On-Time (POT) control method to determine the on-time of the MOSFET with respect to the input and output voltages and an external resistor  $R_{RT}$ . During the on-period, the boost inductor is charged up, and the output capacitor is discharged to provide power to the output. A cycle-by-cycle current limit (which is 3.9A typically and programmable by an external resistor) is imposed on the MOSFET for protection. After the on-period, the MOSFET is turned off such that the boost inductor is discharged. The next on-period is started when the voltage of the FB pin is dropped below a threshold which is determined by Dynamic Headroom Control (DHC) and is ranged from 1.05V to 2.0V (DHC affects the threshold only when the DIM1 and/or DIM2 pins are high). The boost converter under POT control can maintain the switching frequency nearly constant so that the switching frequency depends on only  $R_{RT}$  [Figure 16](#). Also, POT control requires no compensation circuit and gives a fast transient response of the output voltage.

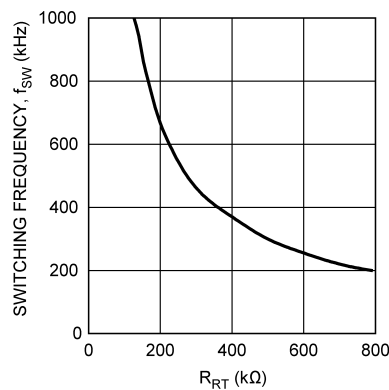

**Figure 16. Switching Frequency**

The two-channel current regulator of the LM3492HC is fast response so that it can allow very high contrast ratio of 10000:1. The two channels are dimmable individually. Channel 1 of the current regulator can be disabled by a digital command send through the COMM pin. In this case, the DIM1 pin can serve only as a clock signal for the data flow of the COMM pin. The power dissipated by the current regulator is adaptively minimized by Dynamic Headroom Control in order to maximize efficiency.

The LM3492HC can be applied in numerous applications like automotive LCD backlight panels. It can operate efficiently for inputs as high as 65V. Diagnostic functions including power good indication, over-temperature indication, IOUT over- and under-voltage indications facilitate the interface of the LM3492HC application circuit with external micro-processors (MCUs). The LM3492HC will not latch off and continue to operate in the presence of the indications. Other useful features include thermal shutdown, VCC under-voltage lock-out, and precision enable. The LM3492HC is available in the thermally enhanced HTSSOP-20 package.

### LDO Regulator

A 5.5V LDO regulator is integrated in the LM3492HC. For stability, an external capacitor  $C_{VCC}$  of more than 0.47  $\mu$ F should be connected between the VCC and GND pins. The current limit of the LDO is typically 30 mA. It can be used to pull-up the open-drain COMM pin with an external resistor, and inject current to the ILIM pin to adjust the current limit of the integrated MOSFET. When the voltage on the VCC pin ( $V_{CC}$ ) is higher than the under-voltage lock-out (UVLO) threshold of 3.78V, the LM3492HC is enabled and the CDHC pin sources a current to charge up an external capacitor  $C_{CDHC}$  to provide a soft-start function.

## Enable and Disable

To enable the LM3492HC, the voltage on the EN pin ( $V_{EN}$ ) must be higher than an enable threshold of typically 1.63V. If  $V_{EN}$  is lower than 1.43V, the LM3492HC is shutdown. In this case, the LDO regulator is turned off and the CDHC pin is internally grounded. The EN pin is internally pulled up. After enable, the EN pin is pulled up by a 40  $\mu$ A current source. If the EN pin is connected to low such that the LM3492HC is shutdown, the pull-up current is reduced to 2  $\mu$ A. These take the advantages that the LM3492HC can effectively avoid false disabling by noise during operation, and minimize power consumption during shutdown. The enable threshold is precise such that it can be used to implement an UVLO function for the input voltage as shown in Figure 17. The input voltage can be connected to the EN pin through a resistor divider consists of  $R_{EN1}$  and  $R_{EN2}$ . This can ensure that the LM3492HC is operated after the input voltage reaches a minimum require value  $V_{IN(EN)}$ , which can be calculated by the following equation:

$$V_{IN(EN)} = 1.63V(1 + R_{EN1}/R_{EN2})$$

A zener diode  $D_{EN}$  should be placed between the EN and GND pins to keep  $V_{EN}$  below its absolute maximum caused by the increase of the input voltage.

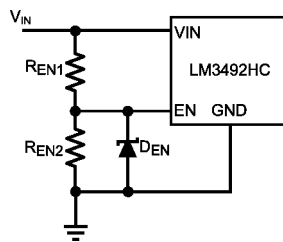

Figure 17. Input Voltage UVLO Implemented by Precision Enable

Once the EN pin is pulled low, the LM3492HC will perform the following functions: reset IOU<sub>T</sub> over- and under-voltage indications and the corresponding COMM bit pattern, resume the switching frequency tuning to the normal frequency, and resume channel 1 of the current regulator if it is disabled. Pulling the EN pin low for a short period of about 200 ns can achieve the above functions with nearly no effect on the operation of the boost converter and the current regulator.

## Current Limit

The current limit  $I_{CL}$  of the integrated MOSFET of the LM3492HC provides a cycle-by-cycle current limit for protection. It can be decreased by injecting a small signal current  $I_{ILIM}$  into the ILIM pin, and the relationship between  $I_{CL}$  and  $I_{ILIM}$  is

$$I_{CL} = I_{CL(MAX)} - 4290 I_{ILIM}$$

where  $I_{CL(MAX)}$  is the maximum current limit. Its typical value is 3.9A. As shown in Figure 18,  $I_{ILIM}$  can be provided by connecting a resistor  $R_{ILIM}$  from the VCC pin to the ILIM pin. The typical voltage on the ILIM pin is 0.7V. To obtain the maximum current limit, connect the ILIM pin to the ground.

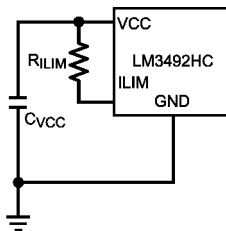

Figure 18. Programmable Current Limit

## Thermal Protection

Thermal protection is implemented by an internal thermal shutdown circuit, which activates at 165°C (typically) to disable the LM3492HC. In this case, the LDO regulator is turned off and the CDHC pin is internally grounded. Thermal protection helps prevent catastrophic failures from accidental device overheating. When the junction temperature of the LM3492HC falls back below 145°C (typical hysteresis = 20°C), the LM3492HC resumes normal operation.

## Dynamic Headroom Control, Over-riding, and Soft-start

Dynamic headroom control (DHC) is implemented in the LM3492HC to adjust the output voltage  $V_{OUT}$  of the boost converter in order to reduce the power loss of the current regulator to maximize efficiency. Let  $V_{LED,n}$  and  $V_{IOUT,n}$  be the forward voltage of an LED string connecting to the IOUTn pin and the voltage of the IOUTn pin, where n is 1, 2 for channels 1, 2 of the current regulator. Since  $V_{LED,n}$  is normally decreasing gradually (in terms of minutes) owing to the rise of LED die temperature during operation, DHC adjust  $V_{OUT}$  by adjusting a threshold which is reflected on the voltage of the FB pin with reference to  $V_{IOUT,n}$ , which is the difference between  $V_{OUT}$  and  $V_{LED,n}$ . The sensitivity of DHC, which is the response time on adjusting  $V_{OUT}$ , is set by  $C_{CDHC}$ . If  $C_{CDHC}$  is small,  $V_{OUT}$  is more sensitive to the variation of  $V_{LED,n}$ .

DHC over-riding can be implemented by internal pull-up or external pull-up (by connecting the CDHC and VCC pins with a resistor, e.g. 10 M $\Omega$ ). In this case, the voltage of the CDHC pin will rise over 2.5V, and the voltage of the FB pin will rise until over-voltage protection is hit. Since the pull-up is weak, DHC over-riding will occur only at low contrast ratio (e.g. <1%).

During startup, the voltage of the CDHC pin is risen from 0V to 2.25V at a speed depends on  $C_{CDHC}$ . This makes the voltage of the FB pin as well as the output voltage ramps up in a controlled manner, and effectively a soft-start function is implemented. The soft-start can be programmable by the  $C_{CDHC}$ .

An internal switch grounds the CDHC pin if any of the following cases happens: (i)  $V_{CC}$  is below the VCC UVLO threshold; (ii) a thermal shutdown occurs; or (iii) the EN pin is pulled low. The CDHC pin cannot be connected to the ground externally.

## Current Regulator

The LM3492HC integrates a two-channel current regulator for controlling the current of two LED strings. The two LED strings are dimmable individually by dimming signals applied to the DIM1 and DIM2 pins for LED strings 1 and 2, which are connected from the VOUT pin to the IOUT1 and IOUT2 pins. The DIM1 and DIM2 pins are internally pulled low. The lowest contrast ratio is 10000:1. The finest pulse width of the dimming signal for the DIM1 and DIM2 pins is 300 ns.

The current of an LED string ( $I_{LED}$ ) is programmable from 50 mA to 250 mA by an external resistor  $R_{IREF}$  connecting from the IREF pin to the ground. The relationship between  $I_{LED}$  and  $R_{IREF}$  is shown in [Figure 19](#). The two channels of the current regulator can work in parallel for only one LED string by connecting the IOUT1 and IOUT2 pins together to provide an LED current of up to 500 mA. In this case, the DIM1 and DIM2 pins should also be connected together.

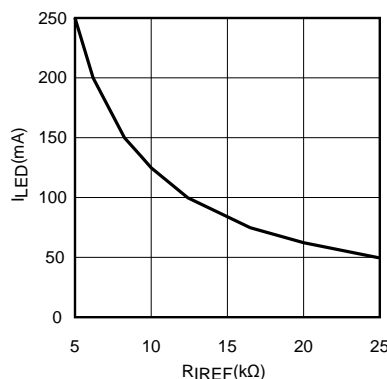

**Figure 19.**  $I_{LED}$  vs  $R_{IREF}$

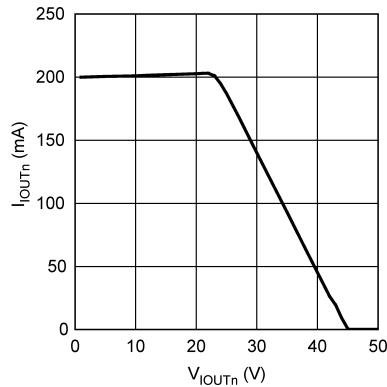

Figure 20. Over-power Protection

If the voltage on the IOUTn (n = 1, 2) pin is over 24V when channel n is on, the regulated current of channel n will be reduced linearly if the voltage further increases (as shown in Figure 20). The regulated current of another channel is not affected. This over-power protection feature avoids damaging the current regulator owing to the shorting of many LEDs in one string.

### Output Voltage Feedback

The output voltage is fed back to the FB pin through a feedback circuit consists of R<sub>FB1</sub>, R<sub>FB2</sub>, and C<sub>FB</sub> as shown in Figure 21. The value of C<sub>FB</sub> is recommended to be 10 pF. in order to help feed the AC component of the output voltage back. The DC component of the output voltage is fed back by R<sub>FB1</sub> and R<sub>FB2</sub>. The voltage of the FB pin V<sub>FB</sub> can be adjusted by DHC. When V<sub>FB</sub> reaches V<sub>FB-OVP</sub>, the maximum output voltage of the boost converter V<sub>OUT(MAX)</sub> reaches its maximum, and it is calculated as follows:

$$V_{OUT(MAX)} = 2.88V (1 + R_{FB1}/ R_{FB2})$$

Under DHC, the output voltage should be maintained at a nominal voltage but not the maximum. The nominal output voltage (V<sub>OUT(NOM)</sub>) is

$$V_{OUT(NOM)} = \max (V_{LED,n} + V_{IOUT,n}), n = 1, 2$$

where V<sub>LED,n</sub> is the forward voltage of LED string n and V<sub>IOUT,n</sub> is the voltage of the IOUTn pin, where n is 1, 2 for channels 1, 2 of the current regulator). The minimum value of V<sub>IOUT,n</sub> is about 5Ω x I<sub>LED</sub>. It is recommended that the nominal voltage of the FB pin (V<sub>FB(NOM)</sub>) is between 1.05V to 2V. Hence, the equation relating V<sub>OUT(MAX)</sub>, V<sub>OUT(NOM)</sub>, and V<sub>FB(NOM)</sub> is as follows:

$$V_{OUT(MAX)} = V_{OUT(NOM)} \times 2.88V / V_{FB(NOM)}$$

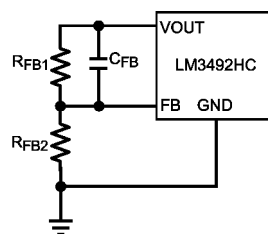

Figure 21. Output Voltage Feedback Circuit

### Over-Voltage Protection

When V<sub>FB</sub> is higher than the FB pin over-voltage protection (OVP) threshold V<sub>FB-OVP</sub> (typically 2.76V and maximum 2.88V), the on-period of the integrated MOSFET stop immediately, and the MOSFET keeps off until V<sub>FB</sub> falls back below below 2.545V (typical hysteresis 0.215V).

An alternative method to implement OVP is to directly monitor  $V_{OUT}$  instead of  $V_{FB}$ . An external circuit as shown in Figure 22 is required. Current is injected to the ILIM pin to drive the LM3492HC to the current limit mode once  $V_{OUT}$  is higher than the avalanche voltage of the zener diode  $D_{OVP}$  plus 0.7V, the typical voltage on the ILIM pin. In this case, a maximum limit of  $V_{OUT}$  is imposed. However, at the maximum limit of  $V_{OUT}$ ,  $V_{FB}$  should be higher than 2.25V to avoid affecting the startup of the LM3492HC.

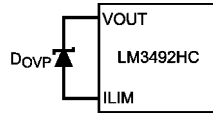

Figure 22. External OVP circuit

## Bi-Directional Communication Pin

The COMM pin of the LM3492HC is an open-drain bi-directional I/O pin for interfacing with an external MCU for the following functions: power-good indication, over-temperature indication, IOUT over- and under-voltage indications, switching frequency tuning, and channel 1 disabling. Except the power good indication and the over-temperature alert, all data flow through the COMM pin is serial and is latched by the falling edge of the signal applying to the DIM1 pin, even when channel 1 of the current regulator is disabled. If the DIM1 pin stays only low or only high, either by an external circuit or letting it open and pull low internally, data flow will not occur. Figure 23 and Figure 24 show a timing diagram of reading and writing a bit from and to the LM3492HC through the COMM pin.

The COMM pin should be pull-up by an MCU I/O pin which has pull-up capability, or an external resistor  $R_{COMM}$  to the VCC pin. Otherwise, the voltage of the COMM pin will remain at zero. The rise time of the output signal of the COMM pin depends on the pull-up power. If the rise time is long ( $R_{COMM}$  is too large or pull-up power from the connecting MCU I/O pin is too weak), data may be ready after a longer duration after the falling edge. In this case, a longer delay between the falling edge latching and the (input or output) bit is required.

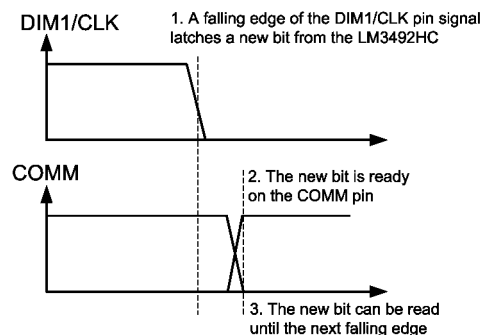

Figure 23. Read from the COMM Pin

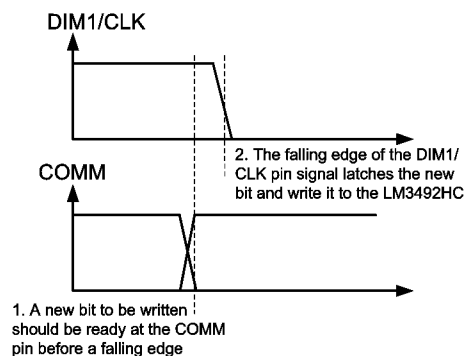

Figure 24. Write to the COMM Pin

## POWER-GOOD INDICATION

Upon startup, the COMM pin reads low. The output voltage of the boost converter of the LM3492HC will rise until the voltage on the FB pin ( $V_{FB}$ ) reaches 2.25V, when the COMM pin reads high to indicate power-good. The power-good indication is independent of the signal applied on the DIM1 pin.

## OVER-TEMPERATURE INDICATION

If the junction temperature of the LM3492HC reaches 135°C, the COMM pin reads low, showing an over-temperature indication. External MCU should consider to turn off or reduce the brightness of the LED strings in order to prevent over-temperature. The over-temperature indication is independent of the signal applied on the DIM1 pin. The COMM pin reads high if the junction temperature falls below 120°C. The LM3492HC will not latch off and continue to operate in the presence of the over-temperature indication.

## IOUT UNDER-VOLTAGE INDICATION

The LM3492HC gives an IOUTn ( $n = 1, 2$ ) under-voltage indication if the voltage of the IOUTn pin when DIMn is high is lower than its minimum required voltage which can regulate  $I_{LED}$ , and the voltage of the CDHC pin reaches its maximum, and these conditions last for 508 consecutively dimming signals applied on the DIMn pin. This means that the current of the LED string n does not reach its regulated value. In most case, the IOUT under-voltage indication can be regarded as an open fault of the LED string n. A bit pattern (refer to [Table 1](#)) can be read from the COMM pin. The LM3492HC will not latch off and continue to operate in the presence of the IOUT under-voltage indication.

## IOUT OVER-VOLTAGE INDICATION

The LM3492HC gives an IOUTn ( $n = 1, 2$ ) over-voltage indication if the voltage of the IOUTn pin when DIMn is high is higher than a threshold of typically 6.5V, and the condition lasts for 508 consecutively dimming signals applied on the DIMn pin. The IOUT over-voltage indication can be regarded as a short fault of the LED string n except the following 2 cases: i) powering up the LM3492HC at a very low dimming ratio such that  $V_{OUT}$  maintains at a maximum and DHC is not fast enough to reduce  $V_{OUT}$ ; ii) under DHC over-riding. A bit pattern (refer to [Table 1](#)) can be read from the COMM pin. The LM3492HC will not latch off and continue to operate in the presence of the IOUT over-voltage indication.

**Table 1. COMM Bit Patterns**

Indication	COMM Bit Pattern
IOUT1 over-voltage indication	0001
IOUT2 over-voltage indication	0011
IOUT1 under-voltage indication	0101
IOUT2 under-voltage indication	0111

## COMM BIT PATTERN

Table 1 summarized all COMM bit patterns of IOUT over- and under-voltage indications. A bit pattern can be read from the COMM pin continuously even the condition causing IOUT over- and under-voltage disappeared. An existing COMM bit pattern will be clear if one of the following condition occurs:

- i) the LM3492HC is shutdown;
- ii) the LM3492HC is disabled by pulling the EN pin low;
- iii) the over-temperature indication is appearing.

To clear the COMM bit pattern without affecting the operation of the boost converter and the current regulator, a reset signal which pulls the EN pin low for about 200 ns can be applied. In this case, the COMM pin will not give bit pattern any more unless a condition causing IOUT over- or under-voltage appears and lasts for 508 consecutively dimming signals.

If an external MCU is used to read the COMM bit pattern, it is recommended that a reset signal should be send to clear the COMM bit pattern after the bit pattern is read. This can avoid that the existing COMM bit pattern is overwritten by another pattern appeared in a later time.

In case of over-temperature, the COMM pin will be pulled low to give an over-temperature indication disregard of any existing COMM bit pattern. After that the over-temperature indication disappears, the COMM bit pattern appeared before the over-temperature indication will appear again.

### SWITCHING FREQUENCY TUNING

After power good, the switching frequency ( $f_{SW}$ ) of the LM3492HC can be tuned down 20% or 40%, or resume normal by writing commands (refer to [Table 2](#)) to the COMM pin. This helps avoid interfering some sensitive devices, for example radios, working nearby the LM3492HC. Upon reset,  $f_{SW}$  of the LM3492HC will resume normal by default. If the over-temperature indication or any COMM bit pattern has already presented, no command can be written to the LM3492HC.

### CHANNEL 1 DISABLE

After power good, channel 1 of the current regulator can be disabled by writing a command (refer to [Table 2](#)) to the COMM pin. If LED string 1 is malfunctioning, channel 1 can be disabled and the signal applied on the DIM1 pin can serve as only a clock signal for the data flow of the COMM pin. Channel 1 is by default enabled after reset. If the over-temperature indication or any COMM bit pattern has already presented, no command can be written to the LM3492HC.

**Table 2. Commands**

Command	Command Bit Pattern
$f_{SW}$ resume normal	1111011101110111
$f_{SW}$ tune down by 20%	1111000100010001
$f_{SW}$ tune down by 40%	1111001100110011
Channel 1 disable	1111010101010101

## Application Information

### EXTERNAL COMPONENTS

The following procedures are to design an LED driver using the LM3492HC with an input voltage ranged from 10V to 24V and two LED strings consists of 10 LEDs each with a forward voltage of 3V for each LED when running at 250 mA. The output power is 15W. The switching frequency  $f_{SW}$  is designed to be 300 kHz.

**$R_{FB1}$ ,  $R_{FB2}$ , and  $C_{FB}$ :** The nominal voltage of the LED string with 10 LEDs is 30V, and the minimum voltage of the IOUTn pin ( $n = 1, 2$ ) is 1.25V when  $I_{LED}$  is 250 mA. As a result,  $V_{OUT(NOM)}$  is 31.25V. Design  $V_{OUT(MAX)}$  to be 50V. From (5),  $V_{FB(NOM)}$  is about 1.8V, which falls in the recommended operation range from 1.05V to 2V. Also, design  $R_{FB2}$  to be 16.2 k $\Omega$ . From (3),  $R_{FB1}$  is calculated to be 265.1 k $\Omega$ , and a standard resistor value of 261 k $\Omega$  is selected.  $C_{FB}$  is selected to be 10 pF as recommended.

**$L_1$ :** The main parameter affected by the inductor is the peak to peak inductor current ripple ( $I_{LR}$ ). To maintain a continuous conduction mode (CCM) operation, the average inductor current  $I_{L1}$  should be larger than half of  $I_{LR}$ . For a boost converter,  $I_{L1}$  equals to the input current  $I_{IN}$ . Hence,

$$I_{IN} = (V_{OUT(NOM)} \times 2I_{LED}) / V_{IN}$$

Also,

$$t_{on} = (1 - V_{IN}/V_{OUT}) / f_{SW}$$

$$L_1 = (V_{IN} \times t_{on}) / 2I_{IN}$$

If  $V_{IN}$  is maximum, which is 24V in this example, and only one LED string is turned on (since the two channels of the LM3492HC are individually dimmable),  $I_{IN}$  is minimum. From (6)-(8), it can be calculated that  $I_{IN(MIN)}$ ,  $t_{on}$ , and  $L_1$  are 0.326A, 0.77  $\mu$ s, and 28.5 $\mu$ H. On the other hand, from (6),  $I_{IN}$  is maximum when  $V_{IN}$  is minimum, which is 10V in this example, and the two LED strings are turned on together. Hence  $I_{IN(MAX)}$  is 1.56A. Then,  $I_{LR}$  is

$$I_{LR} = (V_{IN} \times t_{on}) / L_1$$

From (7),  $t_{on}$  is 2.27  $\mu$ s. From (9),  $I_{LR}$  is 0.80A. The steady state peak inductor current  $I_{L1(PEAK)}$  is

$$I_{L1(PEAK)} = I_{L1} + I_{LR} / 2$$

As a result,  $I_{L1(PEAK)}$  is 1.96A. A standard value of 27  $\mu$ H is selected for  $L_1$ , and its saturation current is larger than 1.96A.



**D<sub>1</sub>:** The selection of the boost diode D<sub>1</sub> depends on two factors. The first factor is the reverse voltage, which equals to V<sub>OUT</sub> for a boost converter. The second factor is the peak diode current at the steady state, which equals to the peak inductor current as shown in (10). In this example, a 100V 3A schottky diode is selected.

**C<sub>IN</sub> and C<sub>OUT</sub>:** The function of the input capacitor C<sub>IN</sub> and the output capacitor C<sub>OUT</sub> is to reduce the input and output voltage ripples. Experimentation is usually necessary to determine their value. The rated DC voltage of capacitors used should be higher than the maximum DC voltage applied. Owing to the concern of product lifetime, ceramic capacitors are recommended. But ceramic capacitors with high rated DC voltage and high capacitance are rare in general. Multiple capacitors connecting in parallel can be used for C<sub>IN</sub> and C<sub>OUT</sub>. In this example, two 10 μF ceramic capacitor are used for C<sub>IN</sub>, and two 2.2 μF ceramic capacitor are used for C<sub>OUT</sub>.

**C<sub>VCC</sub>:** The capacitor on the VCC pin provides noise filtering and stabilizes the LDO regulator. It also prevents false triggering of the VCC UVLO. C<sub>VCC</sub> is recommended to be a 1 μF good quality and low ESR ceramic capacitor.

**C<sub>CDHC</sub>:** The capacitor at the CDHC pin not only affects the sensitivity of the DHC but also determines the soft-start time t<sub>SS</sub>, i.e. the time for the output voltage to rise until power good. t<sub>SS</sub> is determined from the following equation:

$$t_{SS} = \frac{C_{CDHC} \times 2.25V}{120 \mu A}$$

In this example, C<sub>CDHC</sub> is recommended to be a 0.47 μF good quality and low ESR ceramic capacitor.

**R<sub>RT</sub> and R<sub>IREF</sub>:** The resistors R<sub>RT</sub> and R<sub>IREF</sub> set the switching frequency f<sub>SW</sub> of the boost converter and the LED current I<sub>LED</sub> respectively. From Figure 16, if f<sub>SW</sub> is 300 kHz, R<sub>RT</sub> is selected to be 499 kΩ. From Figure 19, if I<sub>LED</sub> is 250 mA, R<sub>IREF</sub> is selected to be 4.99 kΩ.

**R<sub>COMM</sub>:** Since the COMM pin is open drain, a resistor R<sub>COMM</sub> of 52.3 kΩ is used to connect the VCC and COMM pins to act as a pull-up function.

## PC Board Layout

The layout of the printed circuit board is critical in order to optimize the performance of the LM3492HC application circuit. In general, external components should be placed as close to the LM3492HC and each other as possible in order to make copper traces short and direct. In particular, components of the boost converter C<sub>IN</sub>, L<sub>1</sub>, D<sub>1</sub>, C<sub>OUT</sub>, and the LM3492HC should be closed. Also, the output feedback capacitor C<sub>FB</sub> should be closed to the output capacitor C<sub>OUT</sub>. The ground plane connecting the GND, PGND, and LGND pins and the exposed pad of the LM3492HC and the ground connection of the C<sub>IN</sub> and C<sub>OUT</sub> should be placed on the same copper layer.

Good heat dissipation helps optimize the performance of the LM3492HC. The ground plane should be used to connect the exposed pad of the LM3492HC, which is internally connected to the LM3492HC die substrate. The area of the ground plane should be extended as much as possible on the same copper layer around the LM3492HC. Using numerous vias beneath the exposed pad to dissipate heat of the LM3492HC to another copper layer is also a good practice.

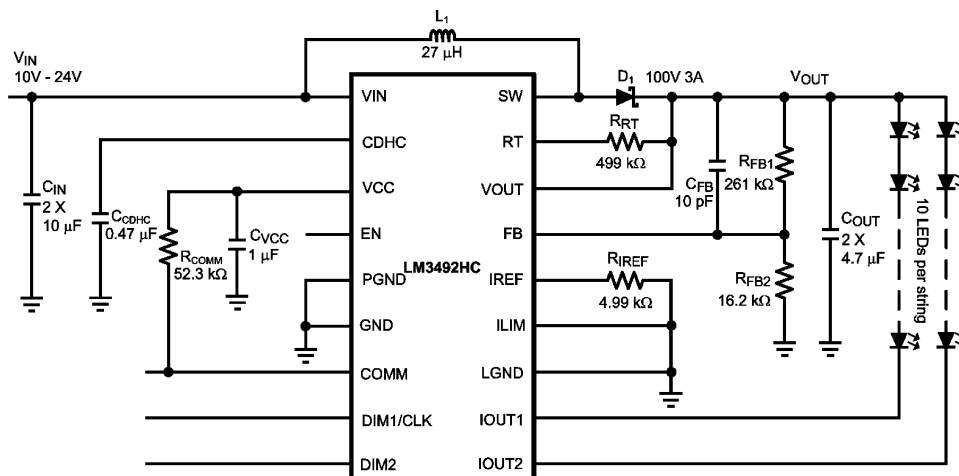

## PACKAGING INFORMATION

Orderable Device	Status (1)	Package Type	Package Drawing	Pins	Package Qty	Eco Plan (2)	Lead/Ball Finish	MSL Peak Temp (3)	Op Temp (°C)	Top-Side Markings (4)	Samples
LM3492HCMH/NOPB	ACTIVE	HTSSOP	PWP	20	73	Green (RoHS & no Sb/Br)	CU SN	Level-1-260C-UNLIM		LM3492 HCMH	<a href="#">Samples</a>
LM3492HCMHX/NOPB	ACTIVE	HTSSOP	PWP	20	2500	Green (RoHS & no Sb/Br)	CU SN	Level-1-260C-UNLIM		LM3492 HCMH	<a href="#">Samples</a>
LM3492HCQMH/NOPB	ACTIVE	HTSSOP	PWP	20	73	Green (RoHS & no Sb/Br)	CU SN	Level-1-260C-UNLIM	-40 to 125	LM3492 HCQMH	<a href="#">Samples</a>
LM3492HCQMHX/NOPB	ACTIVE	HTSSOP	PWP	20	2500	Green (RoHS & no Sb/Br)	CU SN	Level-1-260C-UNLIM	-40 to 125	LM3492 HCQMH	<a href="#">Samples</a>

(1) The marketing status values are defined as follows:

**ACTIVE:** Product device recommended for new designs.

**LIFEBUY:** TI has announced that the device will be discontinued, and a lifetime-buy period is in effect.

**NRND:** Not recommended for new designs. Device is in production to support existing customers, but TI does not recommend using this part in a new design.

**PREVIEW:** Device has been announced but is not in production. Samples may or may not be available.

**OBSOLETE:** TI has discontinued the production of the device.

(2) Eco Plan - The planned eco-friendly classification: Pb-Free (RoHS), Pb-Free (RoHS Exempt), or Green (RoHS & no Sb/Br) - please check <http://www.ti.com/productcontent> for the latest availability information and additional product content details.

**TBD:** The Pb-Free/Green conversion plan has not been defined.

**Pb-Free (RoHS):** TI's terms "Lead-Free" or "Pb-Free" mean semiconductor products that are compatible with the current RoHS requirements for all 6 substances, including the requirement that lead not exceed 0.1% by weight in homogeneous materials. Where designed to be soldered at high temperatures, TI Pb-Free products are suitable for use in specified lead-free processes.

**Pb-Free (RoHS Exempt):** This component has a RoHS exemption for either 1) lead-based flip-chip solder bumps used between the die and package, or 2) lead-based die adhesive used between the die and leadframe. The component is otherwise considered Pb-Free (RoHS compatible) as defined above.

**Green (RoHS & no Sb/Br):** TI defines "Green" to mean Pb-Free (RoHS compatible), and free of Bromine (Br) and Antimony (Sb) based flame retardants (Br or Sb do not exceed 0.1% by weight in homogeneous material)

(3) MSL, Peak Temp. -- The Moisture Sensitivity Level rating according to the JEDEC industry standard classifications, and peak solder temperature.

(4) Only one of markings shown within the brackets will appear on the physical device.

**Important Information and Disclaimer:** The information provided on this page represents TI's knowledge and belief as of the date that it is provided. TI bases its knowledge and belief on information provided by third parties, and makes no representation or warranty as to the accuracy of such information. Efforts are underway to better integrate information from third parties. TI has taken and continues to take reasonable steps to provide representative and accurate information but may not have conducted destructive testing or chemical analysis on incoming materials and chemicals. TI and TI suppliers consider certain information to be proprietary, and thus CAS numbers and other limited information may not be available for release.

In no event shall TI's liability arising out of such information exceed the total purchase price of the TI part(s) at issue in this document sold by TI to Customer on an annual basis.

**OTHER QUALIFIED VERSIONS OF LM3492HC, LM3492HC-Q1 :**

- Catalog: [LM3492HC](#)
- Automotive: [LM3492HC-Q1](#)

NOTE: Qualified Version Definitions:

- Catalog - TI's standard catalog product
- Automotive - Q100 devices qualified for high-reliability automotive applications targeting zero defects

## TAPE AND REEL INFORMATION



### QUADRANT ASSIGNMENTS FOR PIN 1 ORIENTATION IN TAPE



\*All dimensions are nominal

Device	Package Type	Package Drawing	Pins	SPQ	Reel Diameter (mm)	Reel Width W1 (mm)	A0 (mm)	B0 (mm)	K0 (mm)	P1 (mm)	W (mm)	Pin1 Quadrant
LM3492HCMHX/NOPB	HTSSOP	PWP	20	2500	330.0	16.4	6.95	7.1	1.6	8.0	16.0	Q1
LM3492HCQMHX/NOPB	HTSSOP	PWP	20	2500	330.0	16.4	6.95	7.1	1.6	8.0	16.0	Q1

TAPE AND REEL BOX DIMENSIONS



\*All dimensions are nominal

Device	Package Type	Package Drawing	Pins	SPQ	Length (mm)	Width (mm)	Height (mm)
LM3492HCMHX/NOPB	HTSSOP	PWP	20	2500	349.0	337.0	45.0
LM3492HCQMHX/NOPB	HTSSOP	PWP	20	2500	349.0	337.0	45.0

PWP0020A

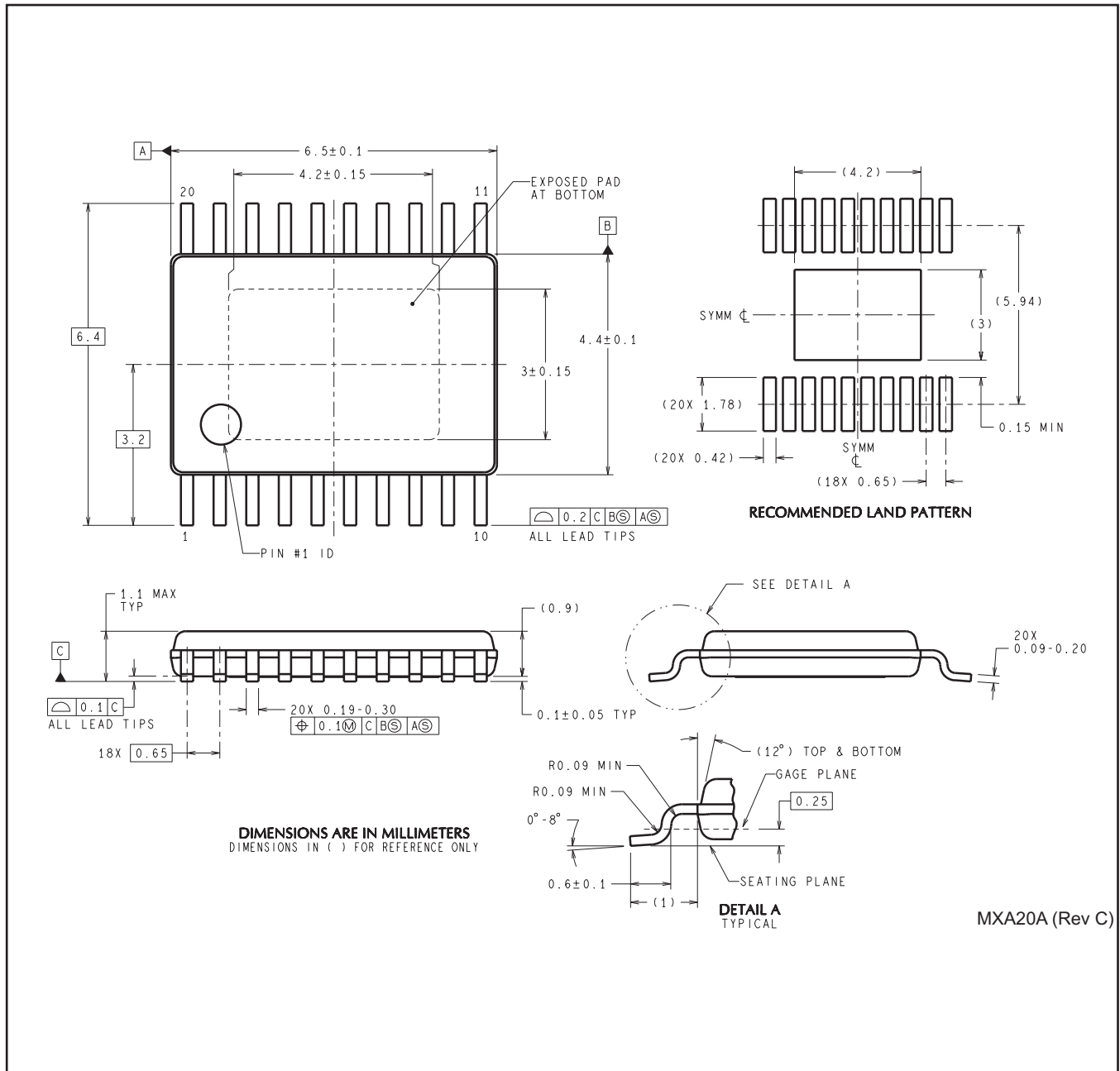

MXA20A (Rev C)

## IMPORTANT NOTICE

Texas Instruments Incorporated and its subsidiaries (TI) reserve the right to make corrections, enhancements, improvements and other changes to its semiconductor products and services per JESD46, latest issue, and to discontinue any product or service per JESD48, latest issue. Buyers should obtain the latest relevant information before placing orders and should verify that such information is current and complete. All semiconductor products (also referred to herein as "components") are sold subject to TI's terms and conditions of sale supplied at the time of order acknowledgment.

TI warrants performance of its components to the specifications applicable at the time of sale, in accordance with the warranty in TI's terms and conditions of sale of semiconductor products. Testing and other quality control techniques are used to the extent TI deems necessary to support this warranty. Except where mandated by applicable law, testing of all parameters of each component is not necessarily performed.

TI assumes no liability for applications assistance or the design of Buyers' products. Buyers are responsible for their products and applications using TI components. To minimize the risks associated with Buyers' products and applications, Buyers should provide adequate design and operating safeguards.

TI does not warrant or represent that any license, either express or implied, is granted under any patent right, copyright, mask work right, or other intellectual property right relating to any combination, machine, or process in which TI components or services are used. Information published by TI regarding third-party products or services does not constitute a license to use such products or services or a warranty or endorsement thereof. Use of such information may require a license from a third party under the patents or other intellectual property of the third party, or a license from TI under the patents or other intellectual property of TI.

Reproduction of significant portions of TI information in TI data books or data sheets is permissible only if reproduction is without alteration and is accompanied by all associated warranties, conditions, limitations, and notices. TI is not responsible or liable for such altered documentation. Information of third parties may be subject to additional restrictions.

Resale of TI components or services with statements different from or beyond the parameters stated by TI for that component or service voids all express and any implied warranties for the associated TI component or service and is an unfair and deceptive business practice. TI is not responsible or liable for any such statements.

Buyer acknowledges and agrees that it is solely responsible for compliance with all legal, regulatory and safety-related requirements concerning its products, and any use of TI components in its applications, notwithstanding any applications-related information or support that may be provided by TI. Buyer represents and agrees that it has all the necessary expertise to create and implement safeguards which anticipate dangerous consequences of failures, monitor failures and their consequences, lessen the likelihood of failures that might cause harm and take appropriate remedial actions. Buyer will fully indemnify TI and its representatives against any damages arising out of the use of any TI components in safety-critical applications.

In some cases, TI components may be promoted specifically to facilitate safety-related applications. With such components, TI's goal is to help enable customers to design and create their own end-product solutions that meet applicable functional safety standards and requirements. Nonetheless, such components are subject to these terms.

No TI components are authorized for use in FDA Class III (or similar life-critical medical equipment) unless authorized officers of the parties have executed a special agreement specifically governing such use.

Only those TI components which TI has specifically designated as military grade or "enhanced plastic" are designed and intended for use in military/aerospace applications or environments. Buyer acknowledges and agrees that any military or aerospace use of TI components which have **not** been so designated is solely at the Buyer's risk, and that Buyer is solely responsible for compliance with all legal and regulatory requirements in connection with such use.

TI has specifically designated certain components as meeting ISO/TS16949 requirements, mainly for automotive use. In any case of use of non-designated products, TI will not be responsible for any failure to meet ISO/TS16949.

### Products

Audio	<a href="http://www.ti.com/audio">www.ti.com/audio</a>
Amplifiers	<a href="http://amplifier.ti.com">amplifier.ti.com</a>
Data Converters	<a href="http://dataconverter.ti.com">dataconverter.ti.com</a>
DLP® Products	<a href="http://www.dlp.com">www.dlp.com</a>
DSP	<a href="http://dsp.ti.com">dsp.ti.com</a>
Clocks and Timers	<a href="http://www.ti.com/clocks">www.ti.com/clocks</a>
Interface	<a href="http://interface.ti.com">interface.ti.com</a>
Logic	<a href="http://logic.ti.com">logic.ti.com</a>
Power Mgmt	<a href="http://power.ti.com">power.ti.com</a>
Microcontrollers	<a href="http://microcontroller.ti.com">microcontroller.ti.com</a>
RFID	<a href="http://www.ti-rfid.com">www.ti-rfid.com</a>
OMAP Applications Processors	<a href="http://www.ti.com/omap">www.ti.com/omap</a>
Wireless Connectivity	<a href="http://www.ti.com/wirelessconnectivity">www.ti.com/wirelessconnectivity</a>

### Applications

Automotive and Transportation	<a href="http://www.ti.com/automotive">www.ti.com/automotive</a>
Communications and Telecom	<a href="http://www.ti.com/communications">www.ti.com/communications</a>
Computers and Peripherals	<a href="http://www.ti.com/computers">www.ti.com/computers</a>
Consumer Electronics	<a href="http://www.ti.com/consumer-apps">www.ti.com/consumer-apps</a>
Energy and Lighting	<a href="http://www.ti.com/energy">www.ti.com/energy</a>
Industrial	<a href="http://www.ti.com/industrial">www.ti.com/industrial</a>
Medical	<a href="http://www.ti.com/medical">www.ti.com/medical</a>
Security	<a href="http://www.ti.com/security">www.ti.com/security</a>
Space, Avionics and Defense	<a href="http://www.ti.com/space-avionics-defense">www.ti.com/space-avionics-defense</a>
Video and Imaging	<a href="http://www.ti.com/video">www.ti.com/video</a>

### TI E2E Community

[e2e.ti.com](http://e2e.ti.com)



## Стандарт Электрон Связь

Мы молодая и активно развивающаяся компания в области поставок электронных компонентов. Мы поставляем электронные компоненты отечественного и импортного производства напрямую от производителей и с крупнейших складов мира.

Благодаря сотрудничеству с мировыми поставщиками мы осуществляем комплексные и плановые поставки широчайшего спектра электронных компонентов.

Собственная эффективная логистика и склад в обеспечивает надежную поставку продукции в точно указанные сроки по всей России.

Мы осуществляем техническую поддержку нашим клиентам и предпродажную проверку качества продукции. На все поставляемые продукты мы предоставляем гарантию .

Осуществляем поставки продукции под контролем ВП МО РФ на предприятия военно-промышленного комплекса России , а также работаем в рамках 275 ФЗ с открытием отдельных счетов в уполномоченном банке. Система менеджмента качества компании соответствует требованиям ГОСТ ISO 9001.

Минимальные сроки поставки, гибкие цены, неограниченный ассортимент и индивидуальный подход к клиентам являются основой для выстраивания долгосрочного и эффективного сотрудничества с предприятиями радиоэлектронной промышленности, предприятиями ВПК и научно-исследовательскими институтами России.

С нами вы становитесь еще успешнее!

### Наши контакты:

**Телефон:** +7 812 627 14 35

**Электронная почта:** [sales@st-electron.ru](mailto:sales@st-electron.ru)

**Адрес:** 198099, Санкт-Петербург,  
Промышленная ул, дом № 19, литера Н,  
помещение 100-Н Офис 331