

## ADDRESS LATCHED 256K (32K x 8) UV EPROM and OTP EPROM

- INTEGRATED ADDRESS LATCH
- FAST ACCESS TIME: 45ns
- LOW POWER "CMOS" CONSUMPTION:
  - Active Current 30mA
  - Standby Current 100µA
- PROGRAMMING VOLTAGE: 12.75V
- ELECTRONIC SIGNATURE for AUTOMATED PROGRAMMING
- PROGRAMMING TIMES of AROUND 3sec. (PRESTO II ALGORITHM)

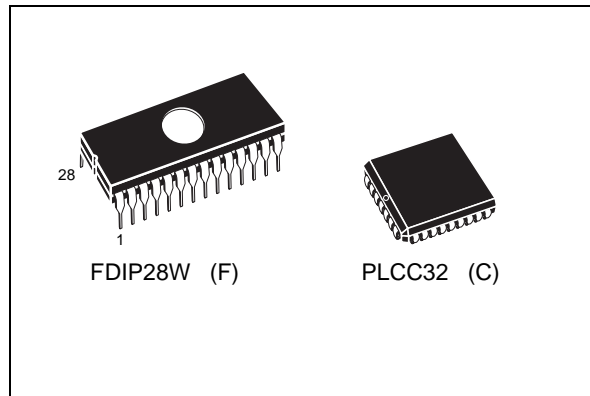

### DESCRIPTION

The M87C257 is a high speed 262,144 bit UV erasable and electrically programmable EPROM. The M87C257 incorporates latches for all address inputs to minimize chip count, reduce cost, and simplify the design of multiplexed bus systems.

The Window Ceramic Frit-Seal Dual-in-Line package has a transparent lid which allows the user to expose the chip to ultraviolet light to erase the bit pattern. A new pattern can then be written to the device by following the programming procedure.

For applications where the content is programmed only one time and erasure is not required, the M87C257 is offered in Plastic Leaded Chip Carrier, package.

**Table 1. Signal Names**

A0 - A14	Address Inputs
Q0 - Q7	Data Outputs
$\bar{E}$	Chip Enable
$\bar{G}$	Output Enable
$\bar{ASV}_{PP}$	Address Strobe / Program Supply
V <sub>CC</sub>	Supply Voltage
V <sub>SS</sub>	Ground

**Figure 1. Logic Diagram**

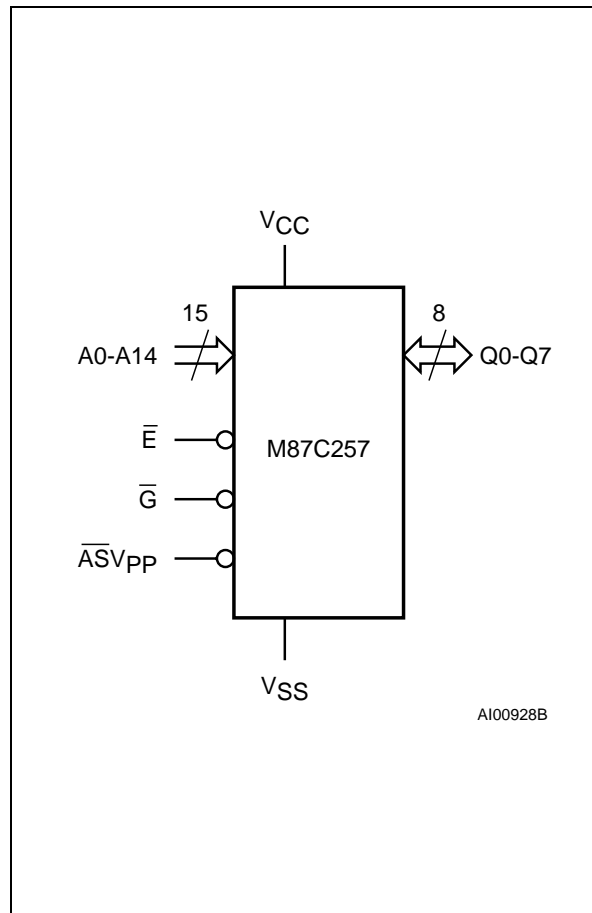

Figure 2A. DIP Pin Connections

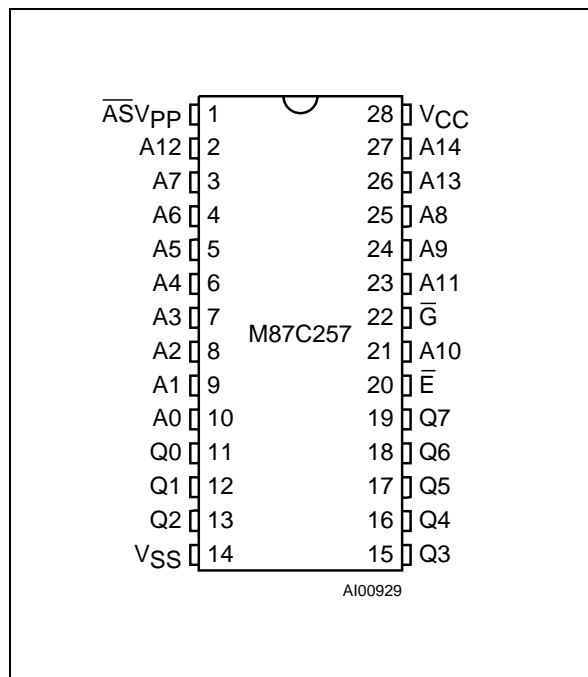
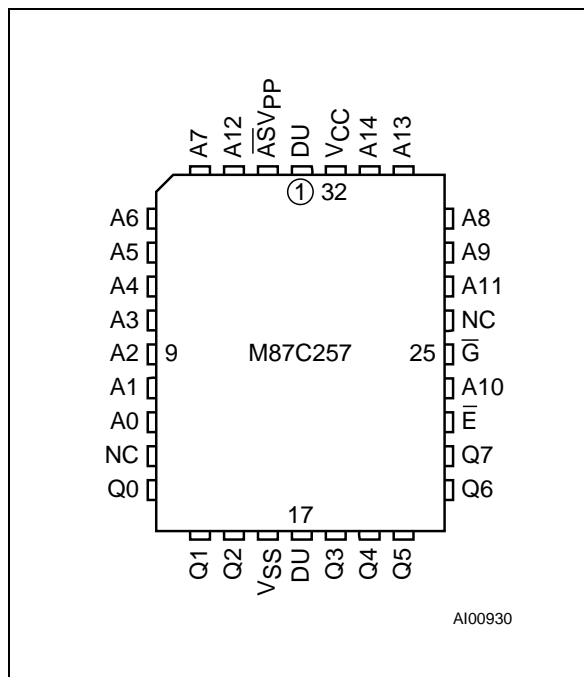

Figure 2B. LCC Pin Connections



Warning: NC = Not Connected, DU = Dont't Use.

Table 2. Absolute Maximum Ratings <sup>(1)</sup>

Symbol	Parameter	Value	Unit
T <sub>A</sub>	Ambient Operating Temperature	-40 to 125	°C
T <sub>BIAS</sub>	Temperature Under Bias	-50 to 125	°C
T <sub>STG</sub>	Storage Temperature	-65 to 150	°C
V <sub>IO</sub> <sup>(2)</sup>	Input or Output Voltages (except A9)	-2 to 7	V
V <sub>CC</sub>	Supply Voltage	-2 to 7	V
V <sub>A9</sub> <sup>(2)</sup>	A9 Voltage	-2 to 13.5	V
V <sub>PP</sub>	Program Supply Voltage	-2 to 14	V

Notes: 1. Except for the rating "Operating Temperature Range", stresses above those listed in the Table "Absolute Maximum Ratings" may cause permanent damage to the device. These are stress ratings only and operation of the device at these or any other conditions above those indicated in the Operating sections of this specification is not implied. Exposure to Absolute Maximum Rating conditions for extended periods may affect device reliability. Refer also to the SGS-THOMSON SURE Program and other relevant quality documents.

2. Minimum DC voltage on Input or Output is -0.5V with possible undershoot to -2.0V for a period less than 20ns. Maximum DC voltage on Output is V<sub>CC</sub> +0.5V with possible overshoot to V<sub>CC</sub> +2V for a period less than 20ns.

**DEVICE OPERATION**

The modes of operation of the M87C257 are listed in the Operating Modes. A single power supply is required in the read mode. All inputs are TTL levels except for V<sub>PP</sub> and 12V on A9 for Electronic Signature.

**Read Mode**

The M87C257 has two control functions, both of which must be logically active in order to obtain data at the outputs. Chip Enable ( $\bar{E}$ ) is the power control and should be used for device selection. Output Enable ( $\bar{G}$ ) is the output control and should

Table 3. Operating Modes

Mode	$\bar{E}$	$\bar{G}$	A9	$\overline{ASV_{PP}}$	Q0 - Q7
Read (Latched Address)	$V_{IL}$	$V_{IL}$	X	$V_{IL}$	Data Out
Read (Applied Address)	$V_{IL}$	$V_{IL}$	X	$V_{IH}$	Data Out
Output Disable	$V_{IL}$	$V_{IH}$	X	X	Hi-Z
Program	$V_{IL}$ Pulse	$V_{IH}$	X	$V_{PP}$	Data In
Verify	$V_{IH}$	$V_{IL}$	X	$V_{PP}$	Data Out
Program Inhibit	$V_{IH}$	$V_{IH}$	X	$V_{PP}$	Hi-Z
Standby	$V_{IH}$	X	X	X	Hi-Z
Electronic Signature	$V_{IL}$	$V_{IL}$	$V_{ID}$	$V_{IL}$	Codes

Note: X =  $V_{IH}$  or  $V_{IL}$ ,  $V_{ID} = 12V \pm 0.5V$

Table 4. Electronic Signature

Identifier	A0	Q7	Q6	Q5	Q4	Q3	Q2	Q1	Q0	Hex Data
Manufacturer's Code	$V_{IL}$	0	0	1	0	0	0	0	0	20h
Device Code	$V_{IH}$	1	0	0	0	0	0	0	0	80h

be used to gate data to the output pins, independent of device selection. Assuming that the addresses are stable ( $\overline{AS} = V_{IH}$ ) or latched ( $\overline{AS} = V_{IL}$ ), the address access time ( $t_{AVQV}$ ) is equal to the delay from  $\bar{E}$  to output ( $t_{ELQV}$ ). Data is available at the output after delay of  $t_{GLQV}$  from the falling edge of  $\bar{G}$ , assuming that  $\bar{E}$  has been low and the addresses have been stable for at least  $t_{AVQV} - t_{GLQV}$ .

The M87C257 reduces the hardware interface in multiplexed address-data bus systems. The processor multiplexed bus (AD0-AD7) may be tied to the M87C257's address and data pins. No separate address latch is needed because the M87C257 latches all address inputs when  $\overline{AS}$  is low.

#### Standby Mode

The M87C257 has a standby mode which reduces the active current from 30mA to 100 $\mu$ A (Address Stable). The M87C257 is placed in the standby mode by applying a CMOS high signal to the  $\bar{E}$  input. When in the standby mode, the outputs are in a high impedance state, independent of the  $\bar{G}$  input.

#### Two Line Output Control

Because EPROMs are usually used in larger memory arrays, this product features a 2 line control function which accommodates the use of multiple memory connection. The two line control function allows:

- the lowest possible memory power dissipation,
- complete assurance that output bus contention will not occur.

For the most efficient use of these two control lines,  $\bar{E}$  should be decoded and used as the primary device selecting function, while  $\bar{G}$  should be made a common connection to all devices in the array and connected to the  $\overline{READ}$  line from the system control bus. This ensures that all deselected memory devices are in their low power standby mode and that the output pins are only active when data is desired from a particular memory device.

**Table 5. AC Measurement Conditions**

	High Speed	Standard
Input Rise and Fall Times	≤ 10ns	≤ 20ns
Input Pulse Voltages	0 to 3V	0.4V to 2.4V
Input and Output Timing Ref. Voltages	1.5V	0.8V and 2V

**Figure 3. AC Testing Input Output Waveform**

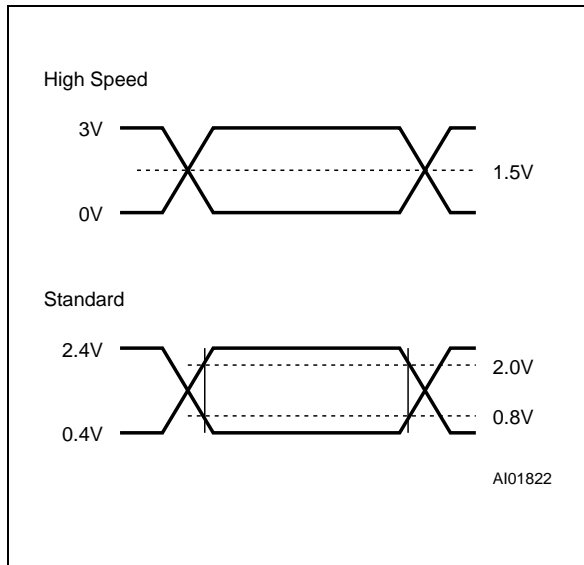

**Figure 4. AC Testing Load Circuit**

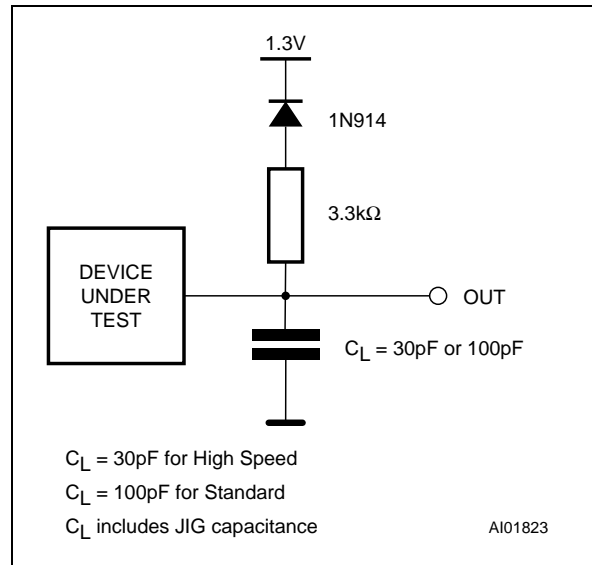

**Table 6. Capacitance <sup>(1)</sup> (T<sub>A</sub> = 25 °C, f = 1 MHz )**

Symbol	Parameter	Test Condition	Min	Max	Unit
C <sub>IN</sub>	Input Capacitance	V <sub>IN</sub> = 0V		6	pF
C <sub>OUT</sub>	Output Capacitance	V <sub>OUT</sub> = 0V		12	pF

**Note:** 1. Sampled only, not 100% tested.

**System Considerations**

The power switching characteristics of Advance CMOS EPROMs require careful decoupling of the devices. The supply current, I<sub>CC</sub>, has three segments that are of interest to the system designer: the standby current level, the active current level, and transient current peaks that are produced by the falling and rising edges of  $\bar{E}$ . The magnitude of this transient current peaks is dependent on the capacitive and inductive loading of the device at the output. The associated transient voltage peaks can be suppressed by complying with the two line

output control and by properly selected decoupling capacitors. It is recommended that a 0.1μF ceramic capacitor be used on every device between V<sub>CC</sub> and V<sub>SS</sub>. This should be a high frequency capacitor of low inherent inductance and should be placed as close to the device as possible. In addition, a 4.7μF bulk electrolytic capacitor should be used between V<sub>CC</sub> and V<sub>SS</sub> for every eight devices. The bulk capacitor should be located near the power supply connection point. The purpose of the bulk capacitor is to overcome the voltage drop caused by the inductive effects of PCB traces.

**Table 7. Read Mode DC Characteristics <sup>(1)</sup>**(T<sub>A</sub> = 0 to 70°C, -40 to 85°C, -40 to 105°C or -40 to 125°C; V<sub>CC</sub> = 5V ± 5% or 5V ± 10%; V<sub>PP</sub> = V<sub>CC</sub>)

Symbol	Parameter	Test Condition	Min	Max	Unit
I <sub>LI</sub>	Input Leakage Current	0V ≤ V <sub>IN</sub> ≤ V <sub>CC</sub>		±10	μA
I <sub>LO</sub>	Output Leakage Current	0V ≤ V <sub>OUT</sub> ≤ V <sub>CC</sub>		±10	μA
I <sub>CC</sub>	Supply Current	$\bar{E} = V_{IL}, \bar{G} = V_{IL},$ I <sub>OUT</sub> = 0mA, f = 5MHz		30	mA
I <sub>CC1</sub>	Supply Current (Standby) TTL	$\bar{E} = V_{IH}, \bar{A} \bar{S} V_{PP} = V_{IH},$ Address Switching		10	mA
		$\bar{E} = V_{IH}, \bar{A} \bar{S} V_{PP} = V_{IL},$ Address Stable		1	mA
I <sub>CC2</sub>	Supply Current (Standby) CMOS	$\bar{E} \geq V_{CC} - 0.2V, \bar{A} \bar{S} V_{PP} \geq V_{CC} - 0.2V,$ Address Switching		6	mA
		$\bar{E} \geq V_{CC} - 0.2V, \bar{A} \bar{S} V_{PP} = V_{SS},$ Address Stable		100	μA
I <sub>PP</sub>	Program Current	V <sub>PP</sub> = V <sub>CC</sub>		100	μA
V <sub>IL</sub>	Input Low Voltage		-0.3	0.8	V
V <sub>IH</sub> <sup>(2)</sup>	Input High Voltage		2	V <sub>CC</sub> + 1	V
V <sub>OL</sub>	Output Low Voltage	I <sub>OL</sub> = 2.1mA		0.4	V
V <sub>OH</sub>	Output High Voltage	I <sub>OH</sub> = -1mA	V <sub>CC</sub> - 0.8V		V

Notes: 1. V<sub>CC</sub> must be applied simultaneously with or before V<sub>PP</sub> and removed simultaneously or after V<sub>PP</sub>.  
2. Maximum DC voltage on Output is V<sub>CC</sub> + 0.5V.

**Table 8A. Read Mode AC Characteristics <sup>(1)</sup>**(T<sub>A</sub> = 0 to 70°C, -40 to 85°C, -40 to 105°C or -40 to 125°C; V<sub>CC</sub> = 5V ± 5% or 5V ± 10%; V<sub>PP</sub> = V<sub>CC</sub>)

Symbol	Alt	Parameter	Test Condition	M87C257								Unit
				-45 <sup>(3)</sup>		-60		-70		-80		
				Min	Max	Min	Max	Min	Max	Min	Max	
t <sub>AVQV</sub>	t <sub>ACC</sub>	Address Valid to Output Valid	$\bar{E} = V_{IL}, G = V_{IL}$		45		60		70		80	ns
t <sub>AVASL</sub>	t <sub>AL</sub>	Address Valid to Address Strobe Low		7		7		7		7		ns
t <sub>ASHASL</sub>	t <sub>LL</sub>	Address Strobe High to Address Strobe Low			35		35	35		35		ns
t <sub>ASLAX</sub>	t <sub>LA</sub>	Address Strobe Low to Address Transition			20		20	20		20		ns
t <sub>ASLGL</sub>	t <sub>LOE</sub>	Address Strobe Low to Output Enable Low			20		20	20		20		ns
t <sub>ELQV</sub>	t <sub>CE</sub>	Chip Enable Low to Output Valid	$\bar{G} = V_{IL}$		45		60		70		80	ns
t <sub>GLQV</sub>	t <sub>OE</sub>	Output Enable Low to Output Valid	$\bar{E} = V_{IL}$		25		30		35		40	ns
t <sub>EHQZ</sub> <sup>(2)</sup>	t <sub>DF</sub>	Chip Enable High to Output Hi-Z	$\bar{G} = V_{IL}$	0	25	0	30	0	30	0	40	ns
t <sub>GHQZ</sub> <sup>(2)</sup>	t <sub>DF</sub>	Output Enable High to Output Hi-Z	$\bar{E} = V_{IL}$	0	25	0	30	0	30	0	40	ns
t <sub>AXQX</sub>	t <sub>OH</sub>	Address Transition to Output Transition	$\bar{E} = V_{IL},$ G = V <sub>IL</sub>	0		0		0		0		ns

Notes: 1. V<sub>CC</sub> must be applied simultaneously with or before V<sub>PP</sub> and removed simultaneously or after V<sub>PP</sub>.  
2. Sampled only, not 100% tested.  
3. In case of 45ns speed see High Speed AC measurement conditions.

**Table 8B. Read Mode AC Characteristics <sup>(1)</sup>**

( $T_A = 0$  to  $70^\circ\text{C}$ ,  $-40$  to  $85^\circ\text{C}$ ,  $-40$  to  $105^\circ\text{C}$  or  $-40$  to  $125^\circ\text{C}$ ;  $V_{CC} = 5\text{V} \pm 5\%$  or  $5\text{V} \pm 10\%$ ;  $V_{PP} = V_{CC}$ )

Symbol	Alt	Parameter	Test Condition	M87C257								Unit
				-90		-10		-12		-15/-20		
				Min	Max	Min	Max	Min	Max	Min	Max	
$t_{AVQV}$	$t_{ACC}$	Address Valid to Output Valid	$\bar{E} = V_{IL}, \bar{G} = V_{IL}$		90		100		120		150	ns
$t_{AVASL}$	$t_{AL}$	Address Valid to Address Strobe Low		7		7		7		7		ns
$t_{ASHASL}$	$t_{LL}$	Address Strobe High to Address Strobe Low		35		35		35		35		ns
$t_{ASLAX}$	$t_{LA}$	Address Strobe Low to Address Transition		20		20		20		20		ns
$t_{ASLGL}$	$t_{LOE}$	Address Strobe Low to Output Enable Low		20		20		20		20		ns
$t_{ELQV}$	$t_{CE}$	Chip Enable Low to Output Valid	$\bar{G} = V_{IL}$		90		100		120		150	ns
$t_{GLQV}$	$t_{OE}$	Output Enable Low to Output Valid	$\bar{E} = V_{IL}$		40		40		50		60	ns
$t_{EHQZ}^{(2)}$	$t_{DF}$	Chip Enable High to Output Hi-Z	$\bar{G} = V_{IL}$	0	40	0	30	0	40	0	40	ns
$t_{GHQZ}^{(2)}$	$t_{DF}$	Output Enable High to Output Hi-Z	$\bar{E} = V_{IL}$	0	40	0	30	0	40	0	40	ns
$t_{AXQX}$	$t_{OH}$	Address Transition to Output Transition	$\bar{E} = V_{IL}, \bar{G} = V_{IL}$	0		0		0		0		ns

Notes: 1.  $V_{CC}$  must be applied simultaneously with or before  $V_{PP}$  and removed simultaneously or after  $V_{PP}$ .  
 2. Sampled only, not 100% tested.

**Figure 5. Read Mode AC Waveforms**

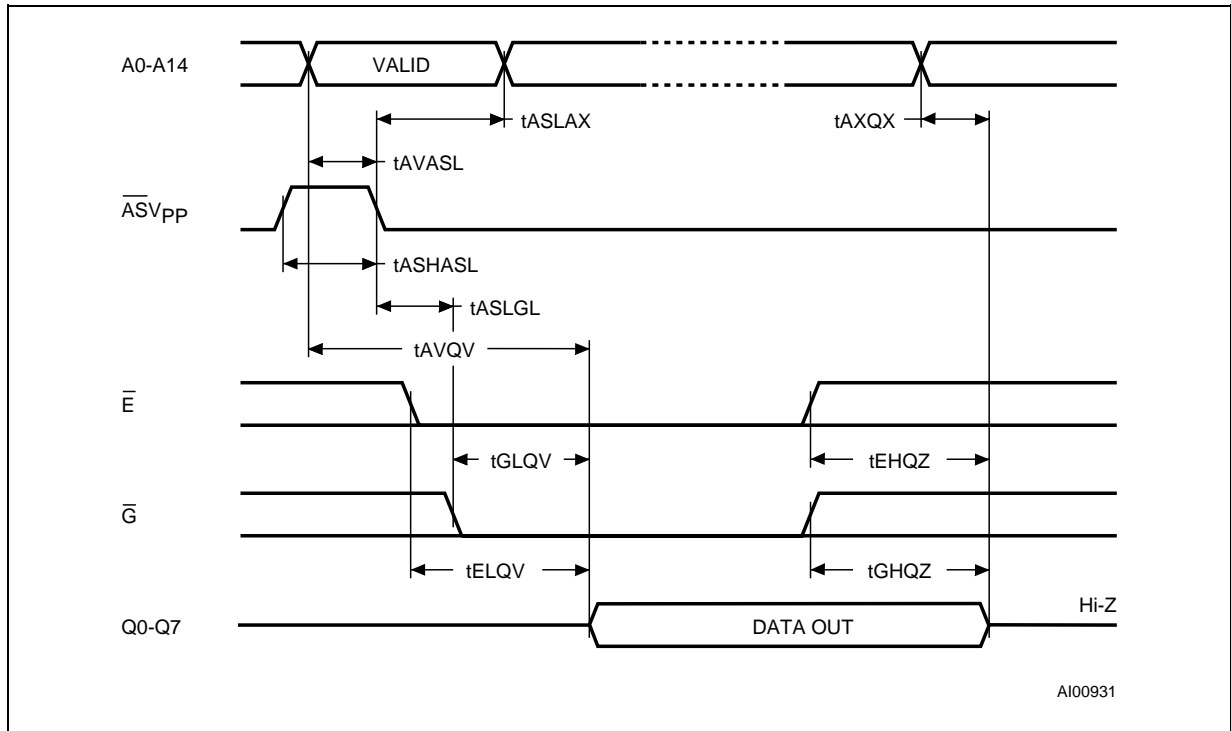

**Table 9. Programming Mode DC Characteristics <sup>(1)</sup>**(T<sub>A</sub> = 25 °C; V<sub>CC</sub> = 6.25V ± 0.25V; V<sub>PP</sub> = 12.75V ± 0.25V)

Symbol	Parameter	Test Condition	Min	Max	Unit
I <sub>LI</sub>	Input Leakage Current	V <sub>IL</sub> ≤ V <sub>IN</sub> ≤ V <sub>IH</sub>		±10	μA
I <sub>CC</sub>	Supply Current			50	mA
I <sub>PP</sub>	Program Current	$\bar{E} = V_{IL}$		50	mA
V <sub>IL</sub>	Input Low Voltage		-0.3	0.8	V
V <sub>IH</sub>	Input High Voltage		2	V <sub>CC</sub> + 0.5	V
V <sub>OL</sub>	Output Low Voltage	I <sub>OL</sub> = 2.1mA		0.4	V
V <sub>OH</sub>	Output High Voltage TTL	I <sub>OH</sub> = -1mA	V <sub>CC</sub> - 0.8V		V
V <sub>ID</sub>	A9 Voltage		11.5	12.5	V

**Note:** 1. V<sub>CC</sub> must be applied simultaneously with or before V<sub>PP</sub> and removed simultaneously or after V<sub>PP</sub>.**Table 10. Programming Mode AC Characteristics <sup>(1)</sup>**(T<sub>A</sub> = 25 °C; V<sub>CC</sub> = 6.25V ± 0.25V; V<sub>PP</sub> = 12.75V ± 0.25V)

Symbol	Alt	Parameter	Test Condition	Min	Max	Unit
t <sub>AVEL</sub>	t <sub>AS</sub>	Address Valid to Chip Enable Low		2		μs
t <sub>QVEL</sub>	t <sub>DS</sub>	Input Valid to Chip Enable Low		2		μs
t <sub>VPHL</sub>	t <sub>VPS</sub>	V <sub>PP</sub> High to Chip Enable Low		2		μs
t <sub>VCHL</sub>	t <sub>VCS</sub>	V <sub>CC</sub> High to Chip Enable Low		2		μs
t <sub>LEH</sub>	t <sub>PW</sub>	Chip Enable Program Pulse Width		95	105	μs
t <sub>EHQX</sub>	t <sub>DH</sub>	Chip Enable High to Input Transition		2		μs
t <sub>QXGL</sub>	t <sub>OES</sub>	Input Transition to Output Enable Low		2		μs
t <sub>GLQV</sub>	t <sub>OE</sub>	Output Enable Low to Output Valid			100	ns
t <sub>GHQZ</sub>	t <sub>DFP</sub>	Output Enable High to Output Hi-Z		0	130	ns
t <sub>GHAX</sub>	t <sub>AH</sub>	Output Enable High to Address Transition		0		ns

**Note:** 1. V<sub>CC</sub> must be applied simultaneously with or before V<sub>PP</sub> and removed simultaneously or after V<sub>PP</sub>.

## Programming

When delivered (and after each erasure for UV EPROM), all bits of the M87C257 are in the "1" state. Data is introduced by selectively programming "0"s into the desired bit locations. Although only "0"s will be programmed, both "1"s and "0"s can be present in the data word. The only way to

change a "0" to a "1" is by die exposition to ultra-violet light (UV EPROM). The M87C257 is in the programming mode when V<sub>PP</sub> input is at 12.75V,  $\bar{G}$  is at V<sub>IH</sub> and  $\bar{E}$  is pulsed to V<sub>IL</sub>. The data to be programmed is applied to 8 bits in parallel to the data output pins. The levels required for the address and data inputs are TTL. V<sub>CC</sub> is specified to be 6.25 V ± 0.25 V.

Figure 6. Programming and Verify Modes AC Waveforms

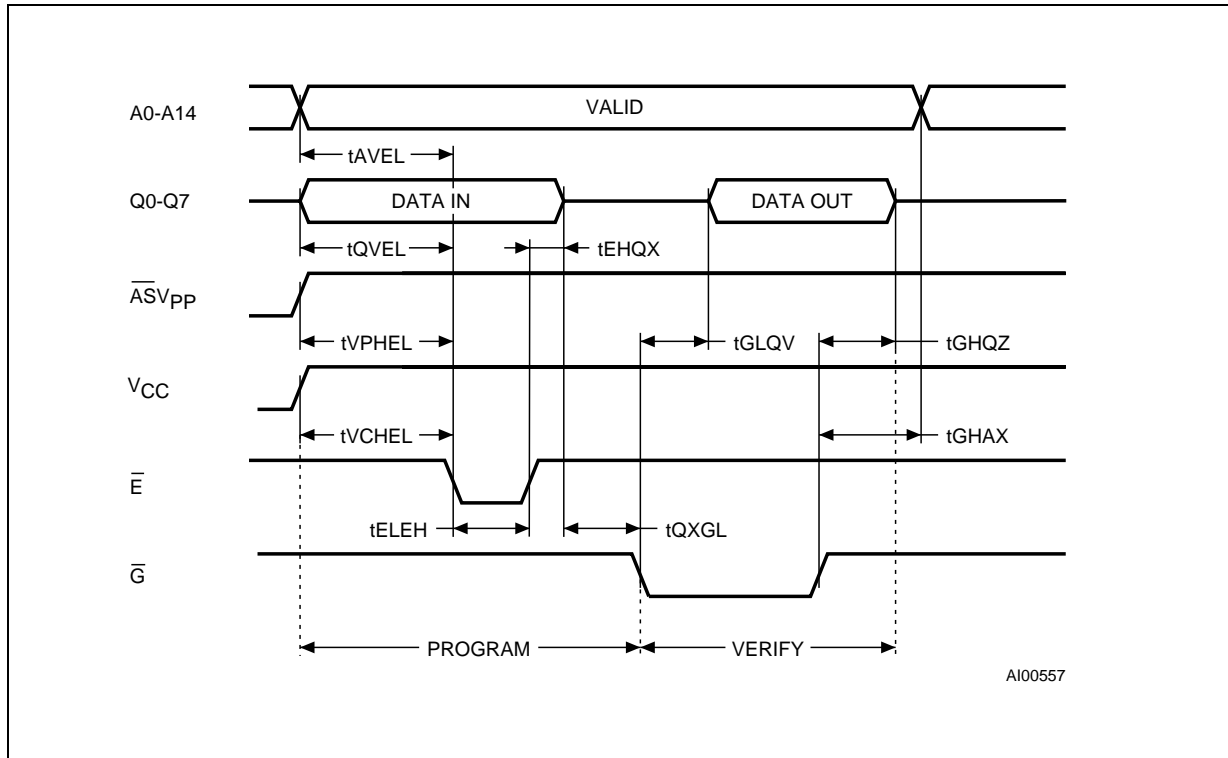
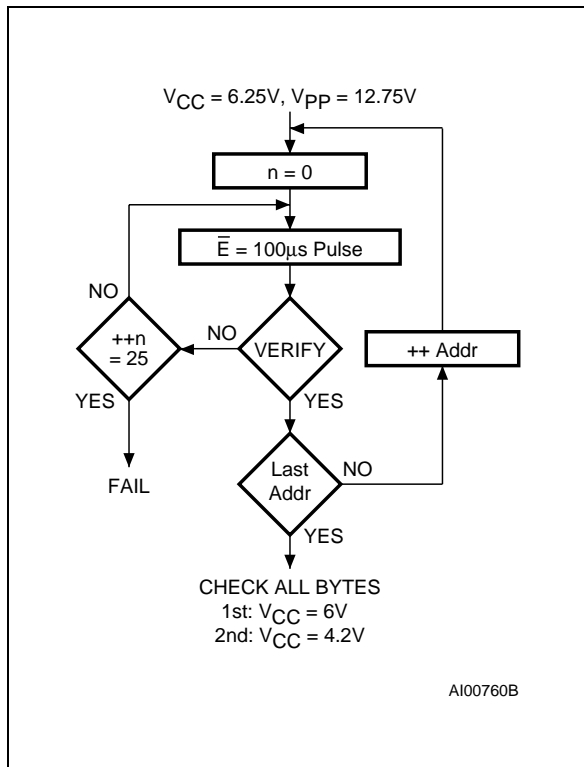

Figure 7. Programming Flowchart



**PRESTO II Programming Algorithm**

PRESTO II Programming Algorithm allows to program the whole array with a guaranteed margin, in a typical time of 3.5 seconds. Programming with PRESTO II involves the application of a sequence of 100µs program pulses to each byte until a correct verify occurs (see Figure 7). During programming and verify operation, a MARGIN MODE circuit is automatically activated in order to guarantee that each cell is programmed with enough margin. No overprogram pulse is applied since the verify in MARGIN MODE provides necessary margin to each programmed cell.

**Program Inhibit**

Programming of multiple M87C257s in parallel with different data is also easily accomplished. Except for  $\bar{E}$ , all like inputs including  $\bar{G}$  of the parallel M87C257 may be common. A TTL low level pulse applied to a M87C257's  $\bar{E}$  input, with V<sub>PP</sub> at 12.75V, will program that M87C257. A high level  $\bar{E}$  input inhibits the other M87C257s from being programmed.

**Program Verify**

A verify (read) should be performed on the programmed bits to determine that they were correctly programmed. The verify is accomplished with  $\bar{G}$  at V<sub>IL</sub>,  $\bar{E}$  at V<sub>IH</sub>, V<sub>PP</sub> at 12.75V and V<sub>CC</sub> at 6.25V.



### Electronic Signature

The Electronic Signature (ES) mode allows the reading out of a binary code from an EPROM that will identify its manufacturer and type. This mode is intended for use by programming equipment to automatically match the device to be programmed with its corresponding programming algorithm. The ES mode is functional in the  $25^{\circ}\text{C} \pm 5^{\circ}\text{C}$  ambient temperature range that is required when programming the M87C257.

To activate the ES mode, the programming equipment must force 11.5V to 12.5V on address line A9 of the M87C257, with  $V_{CC} = V_{PP} = 5\text{V}$ . Two identifier bytes may then be sequenced from the device outputs by toggling address line A0 from  $V_{IL}$  to  $V_{IH}$ . All other address lines must be held at  $V_{IL}$  during Electronic Signature mode. Byte 0 ( $A0=V_{IL}$ ) represents the manufacturer code and byte 1 ( $A0=V_{IH}$ ) the device identifier code. When  $A9 = V_{ID}$ ,  $\overline{A\overline{S}}$  need not be toggled to latch each identifier address. For the SGS-THOMSON M87C257, these two identifier bytes are given in Table 4 and can be read-out on outputs Q0 to Q7.

### ERASURE OPERATION (applies for UV EPROM)

The erasure characteristics of the M87C257 is such that erasure begins when the cells are exposed to light with wavelengths shorter than approximately 4000 Å. It should be noted that sunlight and some type of fluorescent lamps have wavelengths in the 3000-4000 Å range. Research shows that constant exposure to room level fluorescent lighting could erase a typical M87C257 in about 3 years, while it would take approximately 1 week to cause erasure when exposed to direct sunlight. If the M87C257 is to be exposed to these types of lighting conditions for extended periods of time, it is suggested that opaque labels be put over the M87C257 window to prevent unintentional erasure. The recommended erasure procedure for the M87C257 is exposure to short wave ultraviolet light which has wavelength 2537Å. The integrated dose (i.e. UV intensity x exposure time) for erasure should be a minimum of 15 W-sec/cm<sup>2</sup>. The erasure time with this dosage is approximately 15 to 20 minutes using an ultraviolet lamp with 12000 μW/cm<sup>2</sup> power rating. The M87C257 should be placed within 2.5 cm (1 inch) of the lamp tubes during the erasure. Some lamps have a filter on their tubes which should be removed before erasure.

**ORDERING INFORMATION SCHEME**

Example: M87C257 -70 X C 1 X

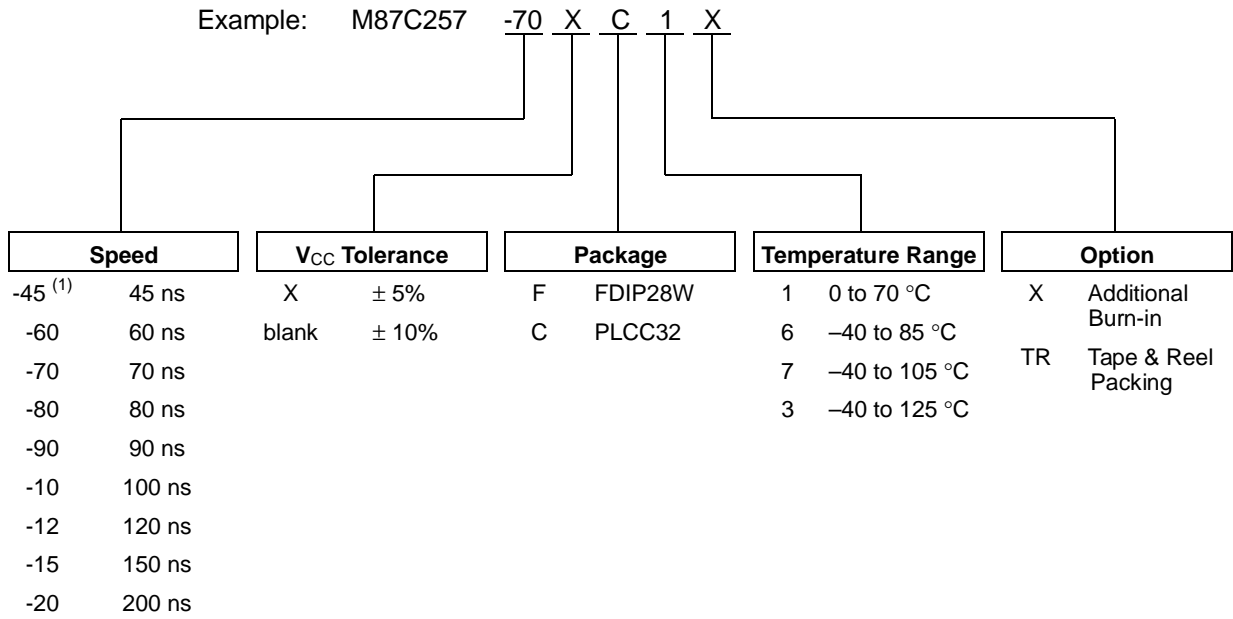

**Note:** 1. High Speed, see AC Characteristics section for further information.

For a list of available options (Speed, V<sub>CC</sub> Tolerance, Package, etc...) refer to the current Memory Shortform catalogue.

For further information on any aspect of this device, please contact the SGS-THOMSON Sales Office nearest to you.

### FDIP28W - 28 pin Ceramic Frit-seal DIP, with window

Symb	mm			inches		
	Typ	Min	Max	Typ	Min	Max
A			5.71			0.225
A1		0.50	1.78		0.020	0.070
A2		3.90	5.08		0.154	0.200
B		0.40	0.55		0.016	0.022
B1		1.17	1.42		0.046	0.056
C		0.22	0.31		0.009	0.012
D			38.10			1.500
E		15.40	15.80		0.606	0.622
E1		13.05	13.36		0.514	0.526
e1	2.54	–	–	0.100	–	–
e3	33.02	–	–	1.300	–	–
eA		16.17	18.32		0.637	0.721
L		3.18	4.10		0.125	0.161
S		1.52	2.49		0.060	0.098
∅	7.11	–	–	0.280	–	–
α		4°	15°		4°	15°
N		28			28	

FDIP28W

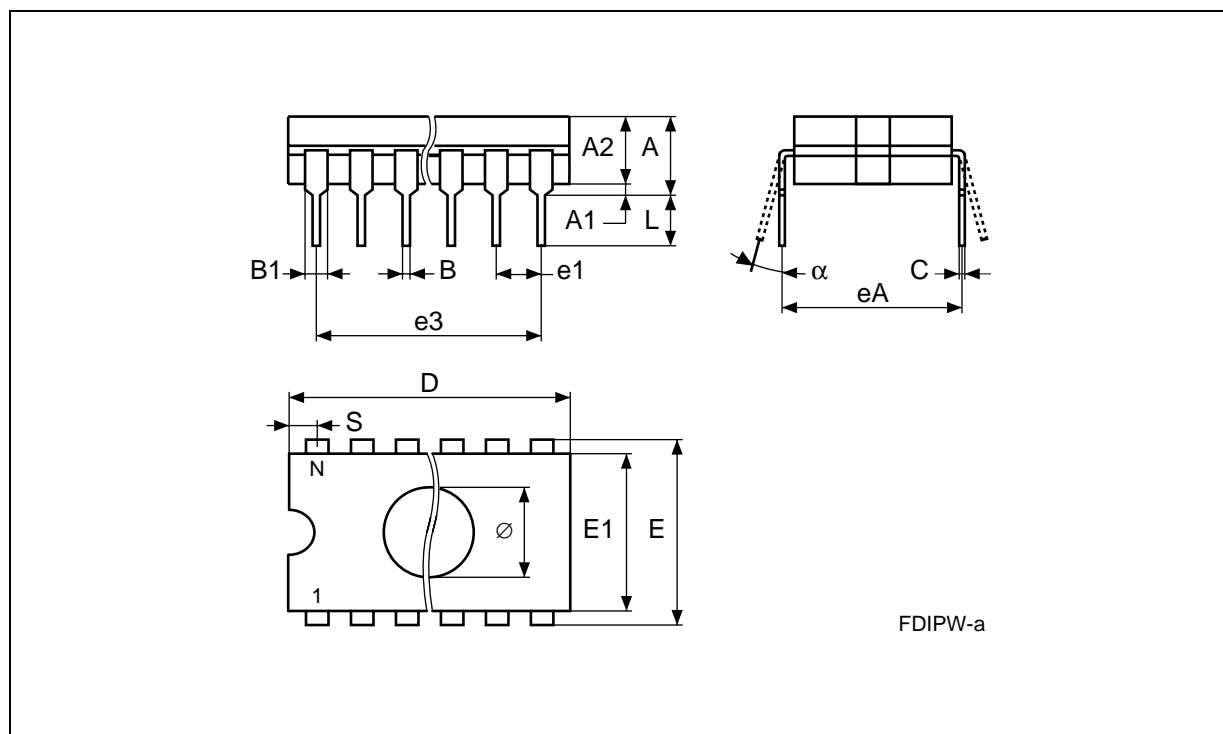

Drawing is not to scale

### PLCC32 - 32 lead Plastic Leaded Chip Carrier, rectangular

Symb	mm			inches		
	Typ	Min	Max	Typ	Min	Max
A		2.54	3.56		0.100	0.140
A1		1.52	2.41		0.060	0.095
B		0.33	0.53		0.013	0.021
B1		0.66	0.81		0.026	0.032
D		12.32	12.57		0.485	0.495
D1		11.35	11.56		0.447	0.455
D2		9.91	10.92		0.390	0.430
E		14.86	15.11		0.585	0.595
E1		13.89	14.10		0.547	0.555
E2		12.45	13.46		0.490	0.530
e	1.27	–	–	0.050	–	–
N		32			32	
Nd		7			7	
Ne		9			9	
CP			0.10			0.004

PLCC32

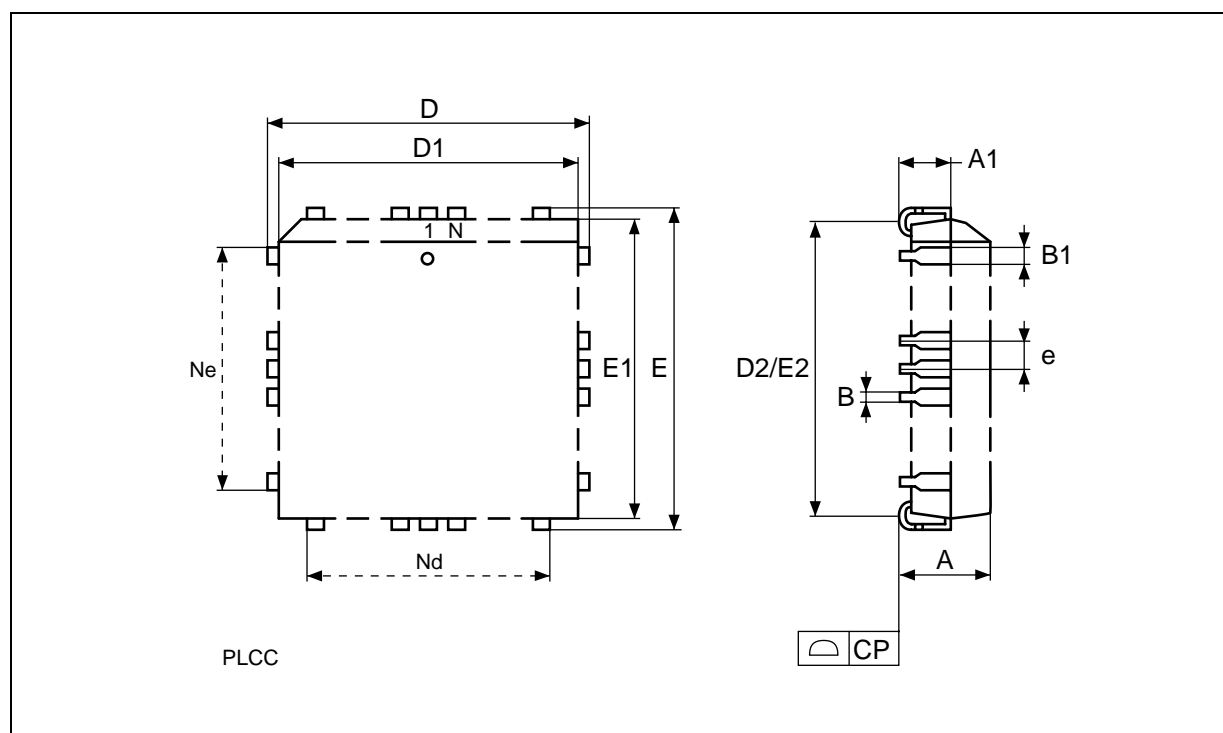

Drawing is not to scale

Information furnished is believed to be accurate and reliable. However, SGS-THOMSON Microelectronics assumes no responsibility for the consequences of use of such information nor for any infringement of patents or other rights of third parties which may result from its use. No license is granted by implication or otherwise under any patent or patent rights of SGS-THOMSON Microelectronics. Specifications mentioned in this publication are subject to change without notice. This publication supersedes and replaces all information previously supplied. SGS-THOMSON Microelectronics products are not authorized for use as critical components in life support devices or systems without express written approval of SGS-THOMSON Microelectronics.

© 1996 SGS-THOMSON Microelectronics - All Rights Reserved

SGS-THOMSON Microelectronics GROUP OF COMPANIES

Australia - Brazil - Canada - China - France - Germany - Hong Kong - Italy - Japan - Korea - Malaysia - Malta - Morocco - The Netherlands - Singapore - Spain - Sweden - Switzerland - Taiwan - Thailand - United Kingdom - U.S.A.



**Стандарт  
Электрон  
Связь**

Мы молодая и активно развивающаяся компания в области поставок электронных компонентов. Мы поставляем электронные компоненты отечественного и импортного производства напрямую от производителей и с крупнейших складов мира.

Благодаря сотрудничеству с мировыми поставщиками мы осуществляем комплексные и плановые поставки широчайшего спектра электронных компонентов.

Собственная эффективная логистика и склад в обеспечивает надежную поставку продукции в точно указанные сроки по всей России.

Мы осуществляем техническую поддержку нашим клиентам и предпродажную проверку качества продукции. На все поставляемые продукты мы предоставляем гарантию .

Осуществляем поставки продукции под контролем ВП МО РФ на предприятия военно-промышленного комплекса России , а также работаем в рамках 275 ФЗ с открытием отдельных счетов в уполномоченном банке. Система менеджмента качества компании соответствует требованиям ГОСТ ISO 9001.

Минимальные сроки поставки, гибкие цены, неограниченный ассортимент и индивидуальный подход к клиентам являются основой для выстраивания долгосрочного и эффективного сотрудничества с предприятиями радиоэлектронной промышленности, предприятиями ВПК и научно-исследовательскими институтами России.

С нами вы становитесь еще успешнее!

**Наши контакты:**

**Телефон:** +7 812 627 14 35

**Электронная почта:** [sales@st-electron.ru](mailto:sales@st-electron.ru)

**Адрес:** 198099, Санкт-Петербург,  
Промышленная ул, дом № 19, литера Н,  
помещение 100-Н Офис 331