

# Using LMZ31520EVM-001, LMZ31530EVM-002 Evaluation Module

## User's Guide



Literature Number: SNVU283

August 2013

1	Description .....	4
2	Getting Started .....	4
3	Test Point Descriptions .....	5
4	Operation Notes .....	5
5	Performance Data .....	6
6	Schematic .....	8
7	Bill of Materials .....	9
8	PCB Layout .....	10

## List of Figures

1	LMZ31520/30EVM User Interface .....	4
2	LMZ31530EVM Efficiency .....	6
3	LMZ31530EVM Power Dissipation .....	6
4	LMZ31530EVM Load Regulation .....	6
5	LMZ31530EVM Output Ripple .....	6
6	LMZ31530EVM Transient Response Waveforms .....	6
7	LMZ31530EVM Transient Response Waveforms .....	6
8	LMZ31530EVM Output Ripple Waveforms .....	7
9	LMZ315xxEVM Schematic.....	8
10	LMZ315x0EVM BOM .....	9
11	EVM Topside Component Layout .....	10
12	EVM Bottom-Side Component Layout.....	10
13	EVM Top Side Copper.....	11
14	EVM Layer 2 Copper.....	11
15	EVM Layer 3 Copper.....	12
16	EVM Layer 4 Copper.....	12
17	EVM Layer 5 Copper.....	13
18	EVM Bottom Side Copper .....	13

## List of Tables

1	Test Point Descriptions.....	5
---	------------------------------	---

# LMZ31520EVM-001 & LMZ31530EVM-002, 20-A & 30-A Simple Switcher® Power Module

The LMZ31520/30 EVM is designed as an easy to use platform that facilitates evaluation of the features and performance of the Simple Switcher® power module. The LMZ31520 and LMZ31530 devices provide output currents of 20A and 30A, respectively. This guide provides information on the correct usage of the EVM and an explanation of the various test points found on the board.

## 1 Description

The EVM features a LMZ31520 (20A) or LMZ31530 (30A), synchronous buck Simple Switcher® power module configured for operation with typical 5-V and 12-V input bus applications. The output voltage can be set to one of six popular values by using a configuration jumper. In similar fashion, the switching frequency can be set to one of four values with a jumper. The full 20-A / 30-A rated output current can be supplied by the EVM. Input and output capacitors are included on the board to accommodate the entire range of input and output voltages. Monitoring test points are provided to allow measurement of efficiency, power dissipation, input ripple, output ripple, line and load regulation, and transient response. Control test points are provided for use of the PWRGD and Inhibit features of the power module along with a selector for Eco-Mode or FCCM. The EVM uses a recommended PCB layout that maximizes thermal performance and minimizes output ripple and noise.

## 2 Getting Started

Figure 1 highlights the user interface items associated with the EVM. The polarized *PVin* Power terminal block (J8) is used for connection to the host input supply and the polarized *Vout* Power terminal block (J11) is used for connection to the load. These terminal blocks can accept up to 16-AWG wire. The polarized VBIAS terminal block (J12) is used along with the VIN SELECT jumper (J4) when optional split power supply operation is desired. Refer to the LMZ31520/30 datasheet for further information on split power supply operation.

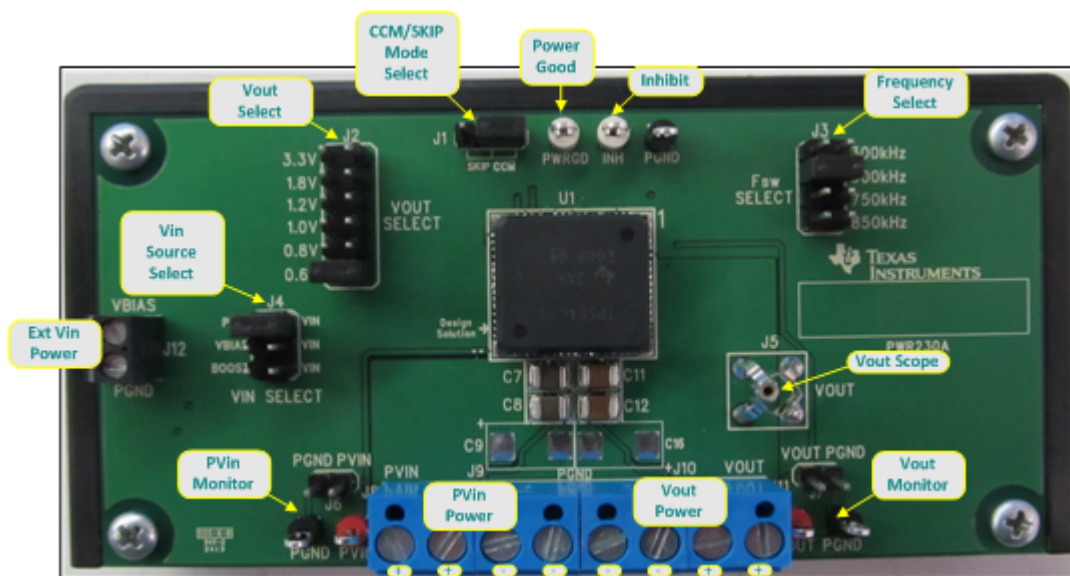

**Figure 1. LMZ31520/30EVM User Interface**

The *PVin Monitor* (TP1) and *Vout Monitor* (TP3) test points located near the power terminal blocks are intended to be used as voltage monitoring points where voltmeters can be connected to measure PVin and Vout. The voltmeter references should be connected to the PGND test points (TP4 & TP2). Do *not* use these PVin and Vout monitoring test points as the input supply or output load connection points. The PCB traces connecting to these test points are not designed to support high currents.

The *PVin Scope* (J6) and *Vout Scope* (J7) test points can be used to monitor PVin and Vout waveforms with an oscilloscope. These test points are intended for use with un-hooded scope probes outfitted with a low-inductance ground lead (ground spring) mounted to the scope barrel. The two sockets of each test point are on 0.1 inch centers. The scope probe tip should be connected to the socket labeled PVin or Vout, and the scope ground lead should be connected to the socket labeled PGND.

The *Vout Scope* (J5) test point can be used to monitor the Vout waveform with an oscilloscope. This test point is intended for use with an un-hooded scope probe with a 3.5 mm ground barrel.

The control test points located directly above the device are made available to test the features of the device. Refer to the [Test Points Descriptions](#) section of this guide for more information on the individual control test points.

The *Vout Select* jumper (J2) and *Fsw Select* jumper (J3) are provided for selecting the desired output voltage and appropriate switching frequency. Before applying power to the EVM, ensure that the jumpers are present and properly positioned for the intended output voltage. Always remove input power before changing the jumper settings.

### 3 Test Point Descriptions

Seven wire-loop test points and three scope probe test points have been provided as convenient connection points for digital voltmeters (DVM) or oscilloscope probes to aid in the evaluation of the device. A description of each test point follows:

**Table 1. Test Point Descriptions<sup>(1)</sup>**

<b>PVIN</b>	Input voltage monitor. Connect DVM to this point for measuring efficiency.
<b>VOUT</b>	Output voltage monitor. Connect DVM to this point for measuring efficiency, line regulation, and load regulation.
<b>PGND</b>	Input and output voltage monitor grounds. Reference the above DVMs to the corresponding ground point.
<b>PVIN Scope (J6)</b>	Input voltage scope monitor. Connect an oscilloscope to this set of points to measure input ripple voltage.
<b>VOUT Scope (J7)</b>	Output voltage scope monitor. Connect an oscilloscope to this set of points to measure output ripple voltage and transient response.
<b>VOUT Scope (J5)</b>	Output voltage scope monitor. Insert an oscilloscope into the test point adapter to measure output ripple voltage and transient response.
<b>PWRGD</b>	Monitors the power good signal of the device. A 100-kΩ pullup resistor is included internal to the device and is tied to 5V. PWRGD is high if the output voltage is within 95% to 110% of its nominal value.
<b>INH</b>	Connect this point to control ground to inhibit the device. Allow this point to float to enable the device.

<sup>(1)</sup> Refer to the product datasheet for absolute maximum ratings associated with above features.

### 4 Operation Notes

In order to operate the EVM using a single power supply, the Vin Select jumper (J4) must be in the default PVIN-VIN position shown in [Figure 1](#). In this position, the PVin and Vin pins of the device are connected together. The UVLO threshold of the EVM is approximately 4.2 V with 0.25 V of hysteresis. The input voltage must be above the UVLO threshold in order to startup the device. After startup, the minimum input voltage to the device must be at least 4.5 V or (Vout + 1.0 V), whichever is greater. The maximum operating input voltage for the device is 15 V. Refer to the product datasheet for further information on the input voltage range, and optional split power supply operation for operating with PVin as low as 3.0 V when using an external Vbias supply.

After application of the proper input voltage, the output voltage of the device will ramp to its final value in approximately 0.7 ms. If desired, this soft-start time can be increased by increasing the value of the R<sub>ss</sub> resistor (R6). Refer to the LMZ31520/30 datasheet for further information on adjusting the soft-start time.

The EVM includes input and output capacitors to accommodate the entire range of input and output voltage conditions. The actual capacitance required will depend on the input and output voltage conditions of the particular application, along with the desired transient response. In most cases, the required output capacitance will be less than that supplied on the EVM. Refer to the LMZ31520/30 datasheet for further information on the minimum required I/O capacitance and transient response.

The LMZ31520/30 can be operated in either Auto-skip Eco-Mode or in Forced Continuous Conduction Mode (FCCM) by selecting the desired mode using J1. Refer to the LMZ31520/30 datasheet for further information on selecting the mode of operation.

## 5 Performance Data

Figure 2 through Figure 8 demonstrate the TPS84A20EVM performance with V<sub>out</sub> = 1.8 V and F<sub>sw</sub> = 500 kHz

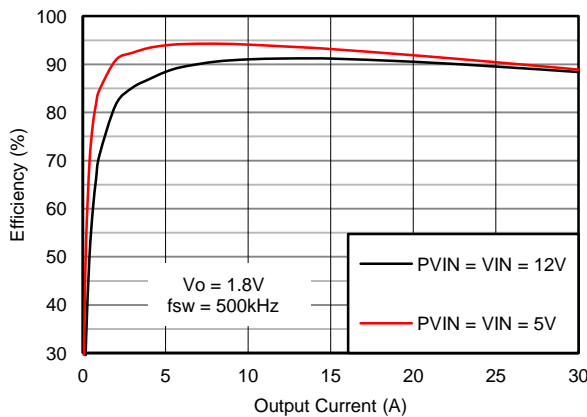

Figure 2. LMZ31530EVM Efficiency

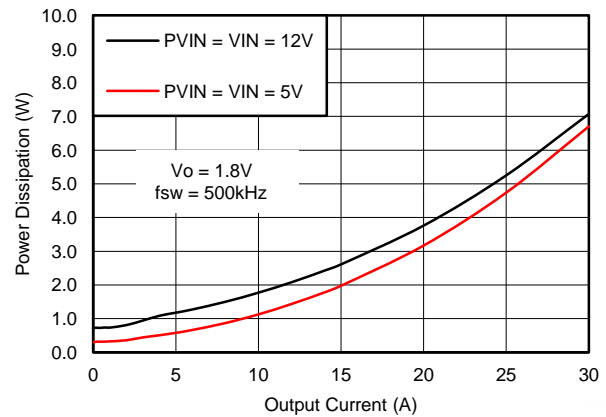

Figure 3. LMZ31530EVM Power Dissipation

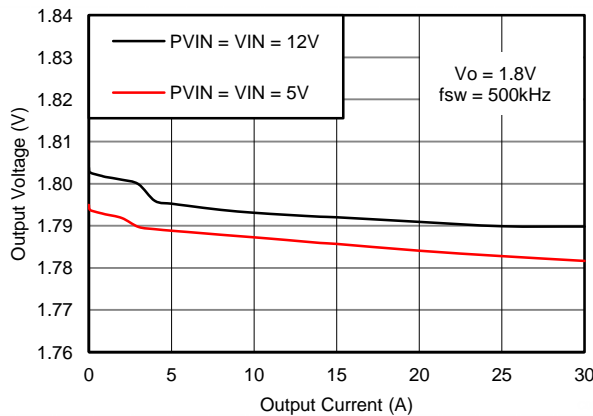

Figure 4. LMZ31530EVM Load Regulation

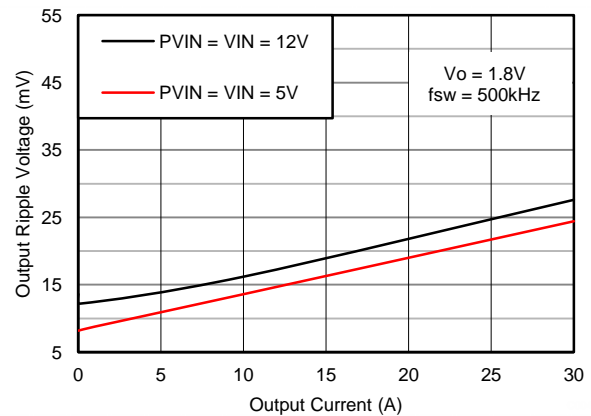

Figure 5. LMZ31530EVM Output Ripple

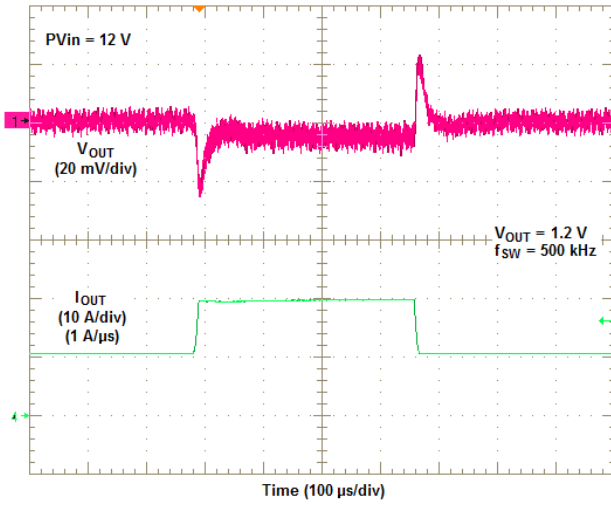

Figure 6. LMZ31530EVM Transient Response Waveforms

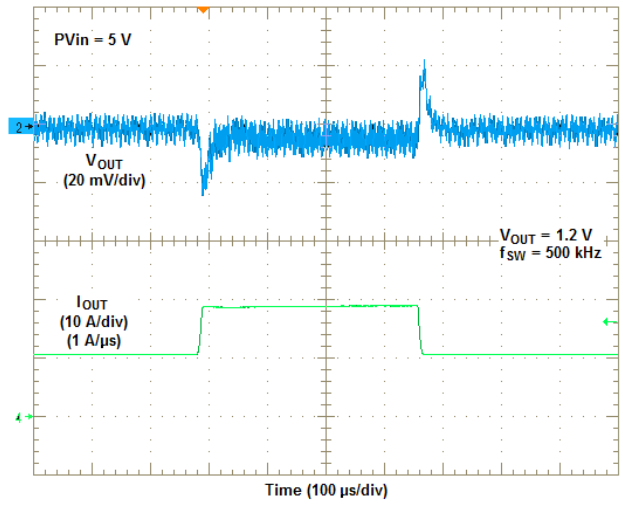

Figure 7. LMZ31530EVM Transient Response Waveforms

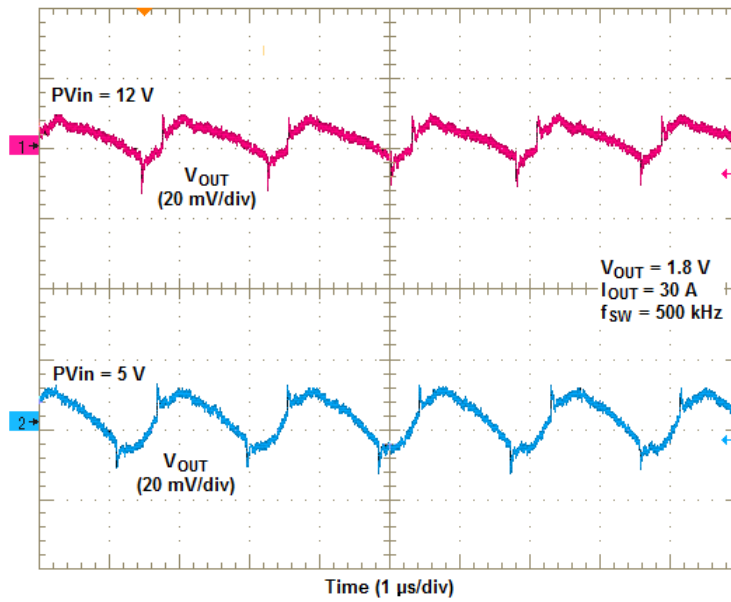

Figure 8. LMZ31530EVM Output Ripple Waveforms

6 Schematic

Figure 9 is the schematic for this EVM.

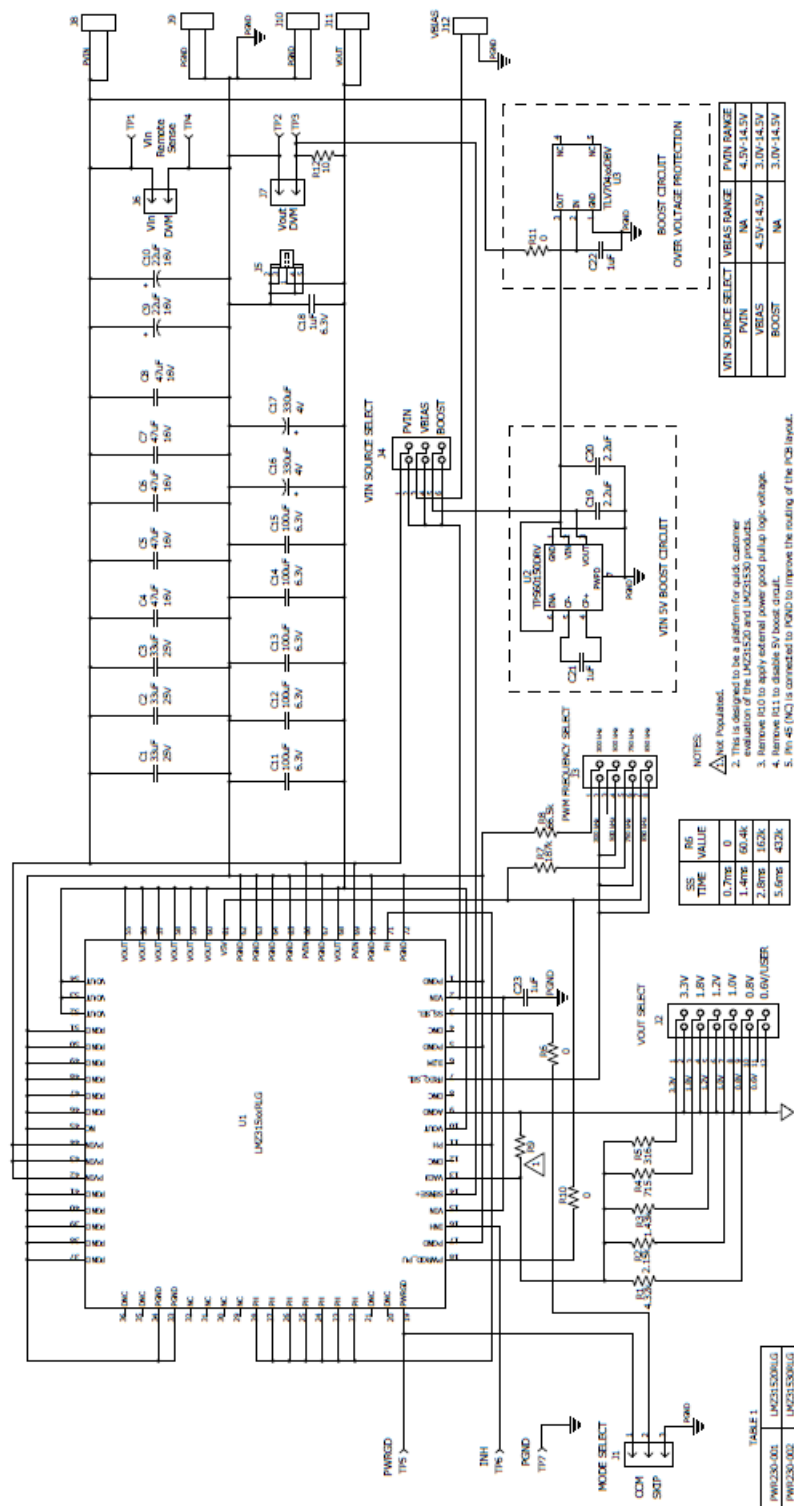

Figure 9. LMZ315xxEVM Schematic



## 7 Bill of Materials

Figure 10 is the BOM for the EVM.

COUNT		RefDes	Value	Description	Size	Part Number	Mfr
-002	-001						
3	3	C1, C2, C3	33uF	Capacitor, Ceramic, 25V, X5R, 20%	1206	C3216X5R1E336M160AC	TDK Corporation
5	5	C4, C5, C6, C7, C8	47uF	Capacitor, Ceramic, 16V, X5R, 10%	1210	EMK325BJ476MM-T	Taiyo Yuden
2	2	C9, C10	22uF	Capacitor, Polymer, 16V, 20%	2917	A700D226M016ATE018	Kemet
5	5	C11, C12, C13, C14, C15	100uF	Capacitor, Ceramic, 6.3V, X5R, 20%	1210	C3225X5R0J107M250AC	TDK Corporation
2	2	C16, C17	330uF	Capacitor, Polymer, 4V, 20%	2917	EEF-UE0G331R	Panasonic
1	1	C18	1uF	Capacitor, Ceramic, 6.3V, X5R, 10%	0603	C1608X5R0J105K	TDK Corporation
2	2	C19, C20	2.2uF	Capacitor, Ceramic, 6.3V, X5R, 10%	0805	C2012X5R0J225M085AA	TDK Corporation
1	1	C21	1uF	Capacitor, Ceramic, 6.3V, X5R, 10%	0805	C0805C105K9PACTU	Kemet
2	2	C22, C23	1uF	Capacitor, Ceramic, 25V, X5R, 10%	0805	C2012X5R1E105K085AC	TDK Corporation
1	1	J1	PEC03SAAN	Header, Male, 1x3 pin, 0.1" centers	0.100 inch x 1 x 3	PEC03SAAN	Sullins
1	1	J2	PEC06DAAN	Header, Male, 2x6 pin, 0.1" centers	0.100 inch x 2 x 6	PEC06DAAN	Sullins
1	1	J3	PEC04DAAN	Header, Male, 2x4 pin, 0.1" centers	0.100 inch x 2 x 4	PEC04DAAN	Sullins
1	1	J4	PEC03DAAN	Header, Male, 2x3 pin, 0.1" centers	0.100 inch x 2 x 3	PEC03DAAN	Sullins
1	1	J5	131-5031-00	CB TEST POINT ADAPTER, 5mm	0.690 x 0.690 inch	131-5031-00	Tektronix
2	2	J6, J7	PEC02SAAN	Header, Male, 1x2 pin, 0.1" centers	0.100 inch x 1 x 2	PEC02SAAN	Sullins
4	4	J8, J9, J10, J11	ED120/2DS	Terminal Block, 2-pin, 15A, 5.1mm	0.40 x 0.35 inch	ED120/2DS	On Shore Technology
1	1	J12	ED555/2DS	Terminal Block, 2-pin, 6-A, 3.5mm	3.5 mm x 1 x 2	ED555/2DS	On Shore Technology
1	1	R1	4.32k	Resistor, Chip, 1/16W, 1%	0603	CRCW06034K32FKEA	Vishay Dale
1	1	R2	2.15k	Resistor, Chip, 1/16W, 1%	0603	CRCW06032K15FKEA	Vishay Dale
1	1	R3	1.43k	Resistor, Chip, 1/16W, 1%	0603	CRCW06031K43FKEA	Vishay Dale
1	1	R4	715	Resistor, Chip, 1/16W, 1%	0603	CRCW0603715RFKEA	Vishay Dale
1	1	R5	316	Resistor, Chip, 1/16W, 1%	0603	CRCW0603316RFKEA	Vishay Dale
3	3	R6, R10, R11	0	Resistor, Chip, 1/16W, 1%	0603	ERJ-3GEY0R00V	Panasonic
1	1	R7	187k	Resistor, Chip, 1/16W, 1%	0603	CRCW0603187KFKEA	Vishay Dale
1	1	R8	66.5k	Resistor, Chip, 1/16W, 1%	0603	CRCW060366K5FKEA	Vishay Dale
0	0	R9	optional (user-defined)	Resistor, Chip, 1/16W, 1%	0402	optional (user-defined)	optional (user-defined)
1	1	R12	10	Resistor, Chip, 1/16W, 1%	0603	CRCW060310R0FKEA	Vishay Dale
2	2	TP1, TP3	5010	Test Point, Red, Wire Loop, Thru Hole	0.125 x 0.125 inch	5010	Keystone
3	3	TP2, TP4, TP7	5011	Test Point, Black, Wire Loop, Thru Hole	0.125 x 0.125 inch	5011	Keystone
2	2	TP5, TP6	5012	Test Point, White, Wire Loop, Thru Hole	0.125 x 0.125 inch	5012	Keystone
0	1	U1	LMZ31520RLG	IPS, Sync Buck, 3 to 14.5V Input, 30A Output	15x16x5.8 mm QFN	LMZ31520RLG	TI
1	0	U1	LMZ31530RLG	IPS, Sync Buck, 3 to 14.5V Input, 20A Output	15x16x5.8 mm QFN	LMZ31530RLG	TI
1	1	U2	TPS60150DRV	150mA 5V charge pump	2x2x0.8 mm QFN	TPS60150DRV	TI
1	1	U3	TLV70450DBV	24-V Input, 150 mA, 5.0V LDO Regulator	3x3x1.45 mm SOT-23	TLV70450DBV	TI
4	4	---	---	Shunt, Black	0.100 inch x 1 x 2	929950-00	3M
4	4	---	---	Bumpon, Hemisphere, Black	0.44 Dia. x 0.20 inch	SJ-5003	3M
1	1	---	---	PCB, 2" x 4" x 0.062"	2 x 4 x 0.062 inch	PWR203	Any
1	1	---	---	Label	1.25 x 0.25 inch	THT-13-457-10	Brady

Figure 10. LMZ315x0EVM BOM

## 8 PCB Layout

Figure 11 through Figure 18 show the PCB layout layers of the EVM.

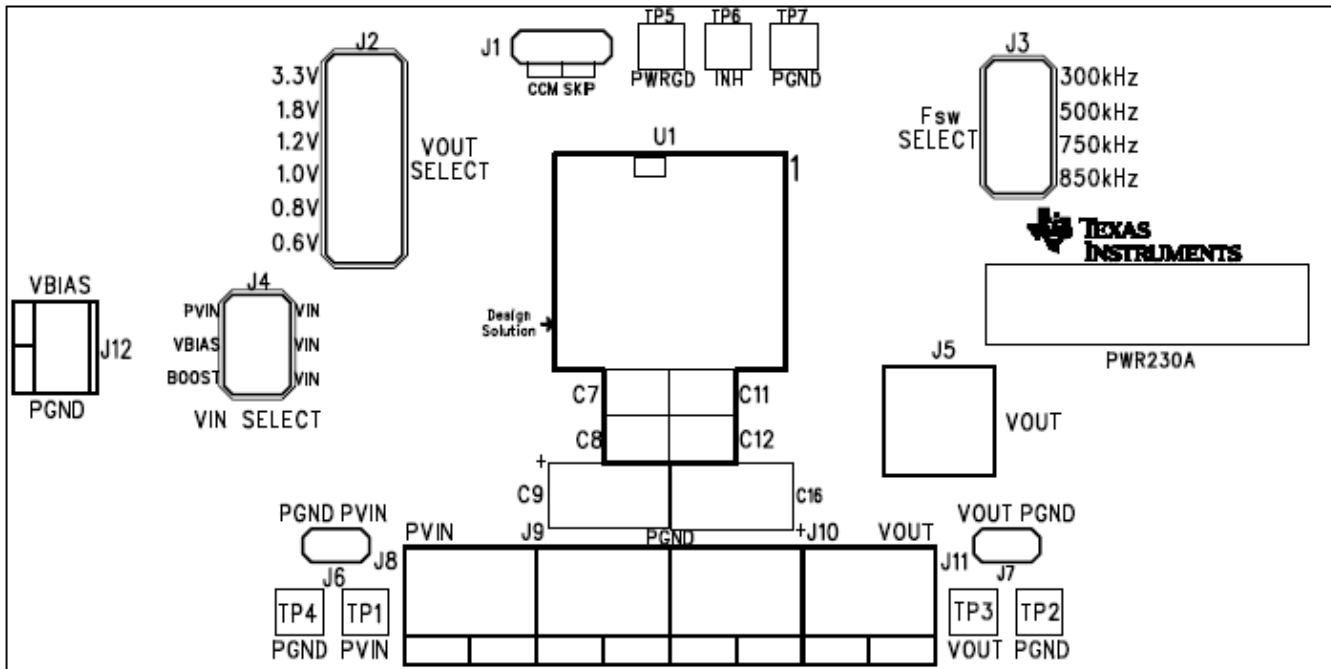

Figure 11. EVM Topside Component Layout

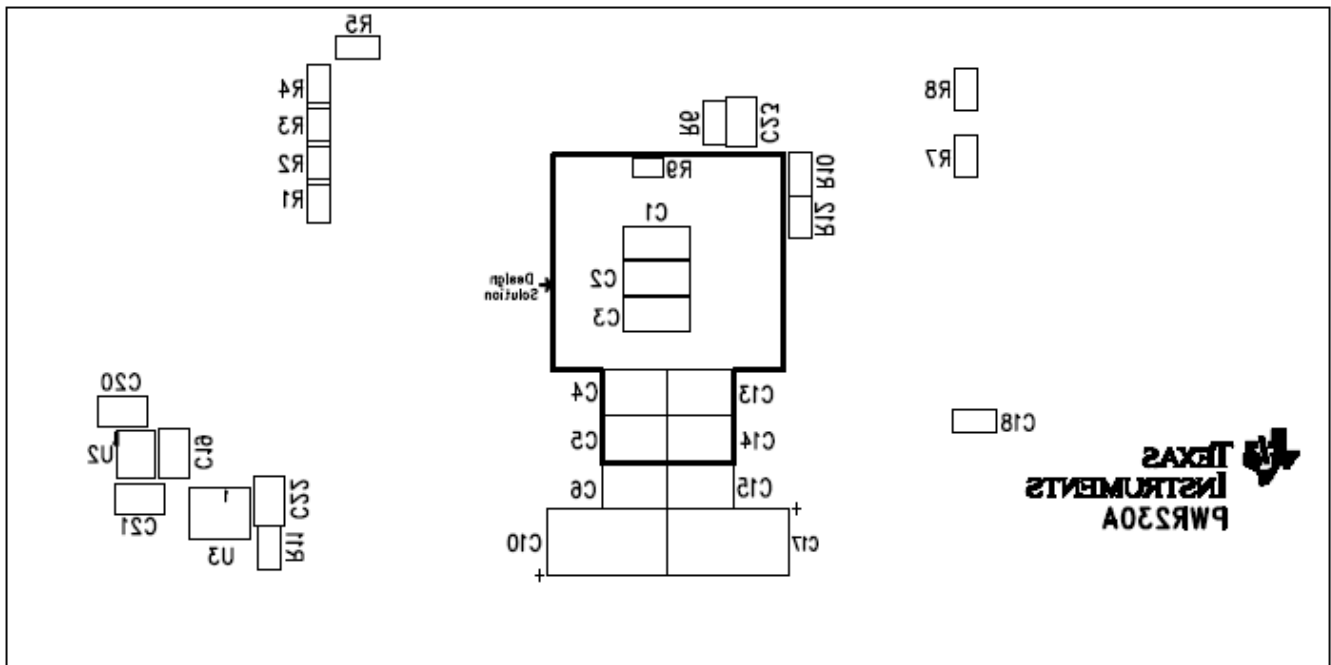

Figure 12. EVM Bottom-Side Component Layout

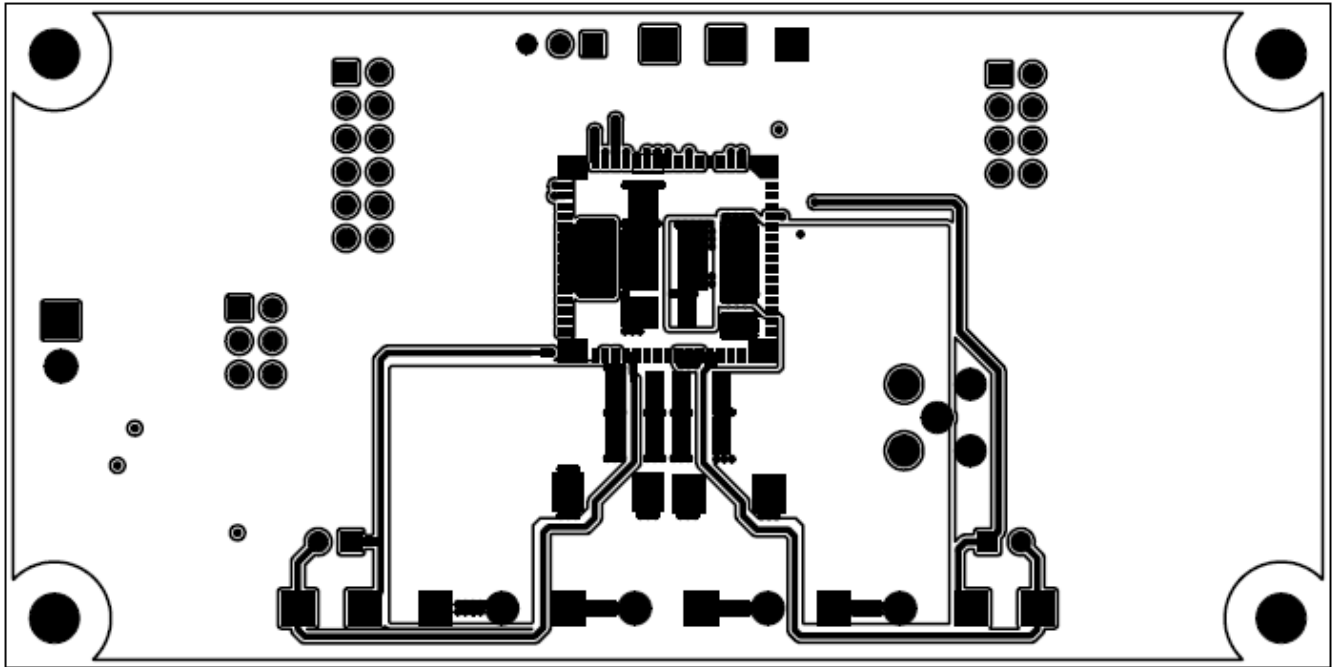

Figure 13. EVM Top Side Copper

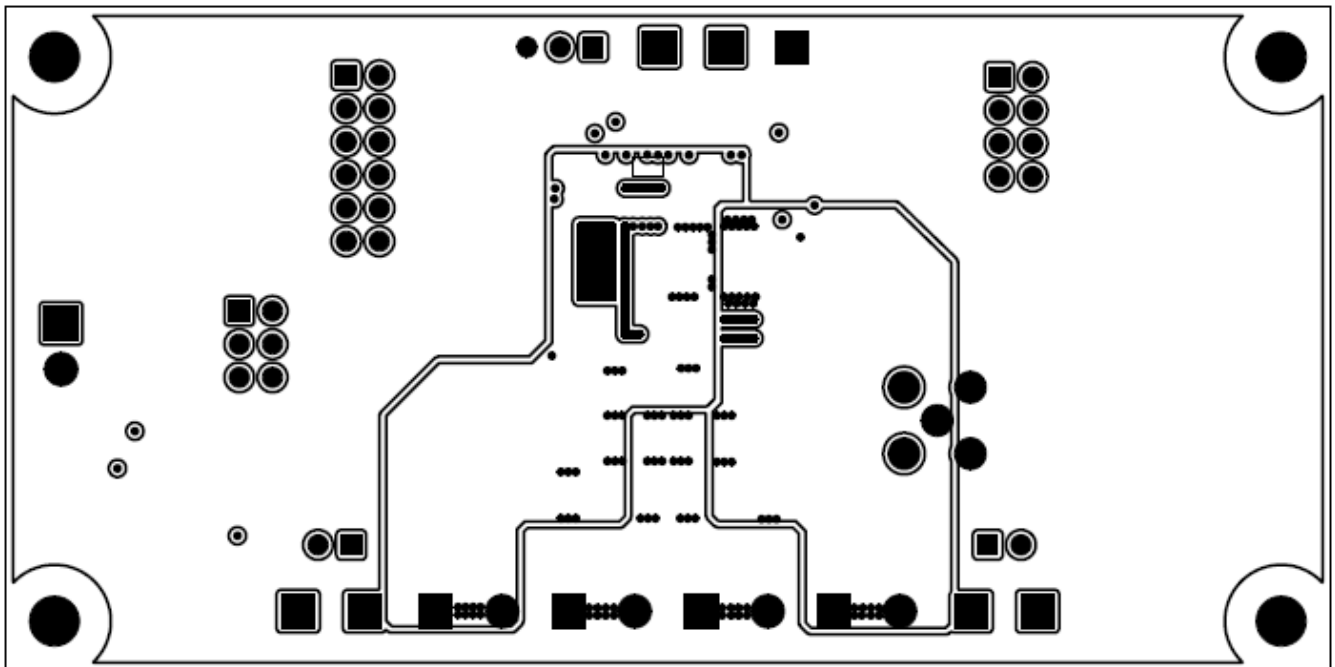

Figure 14. EVM Layer 2 Copper

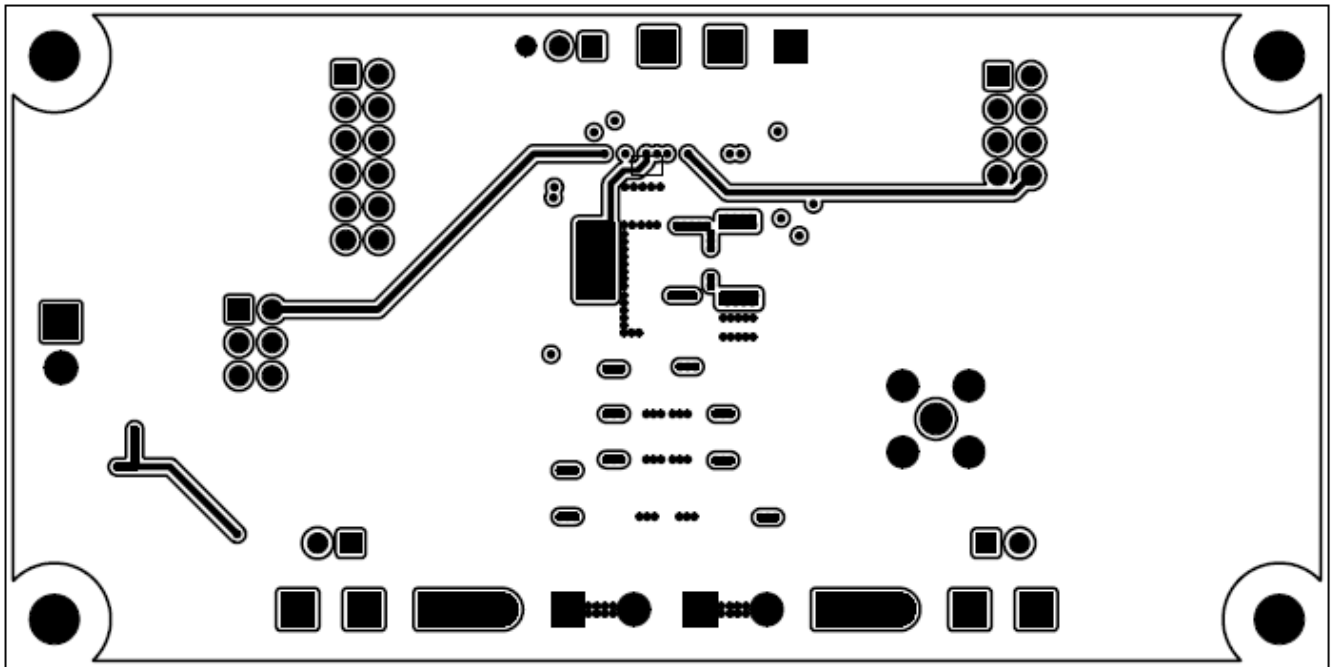

Figure 15. EVM Layer 3 Copper

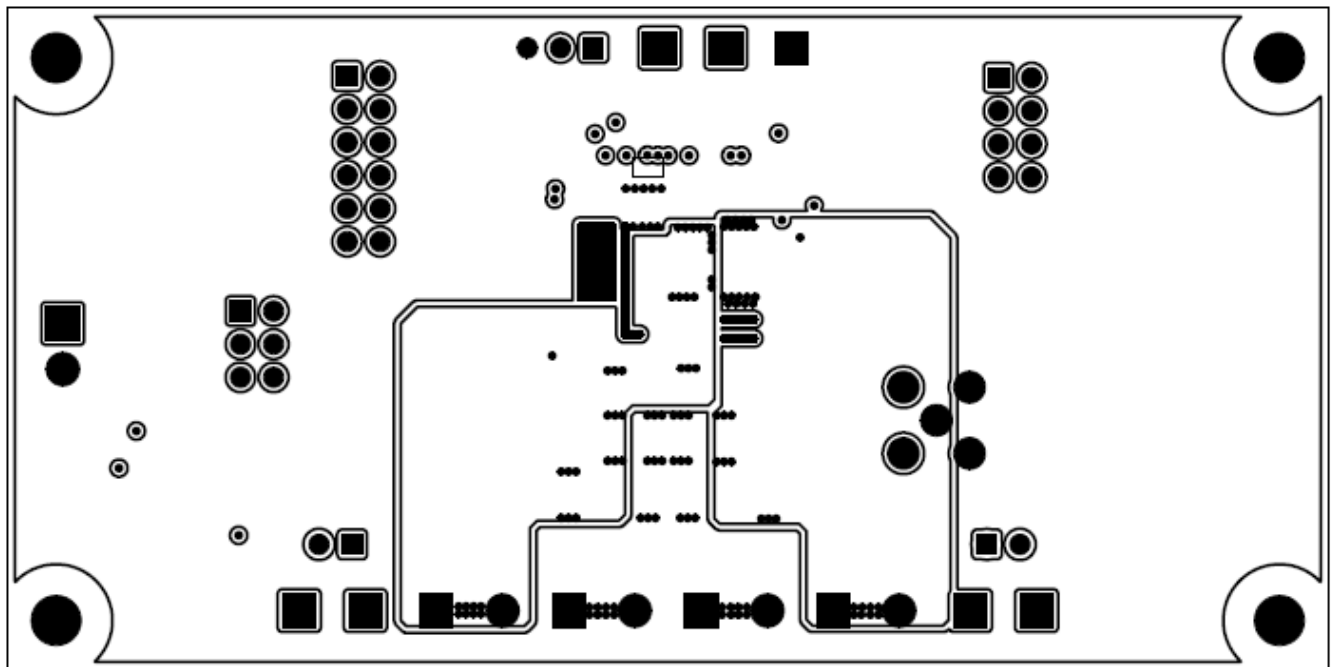

Figure 16. EVM Layer 4 Copper

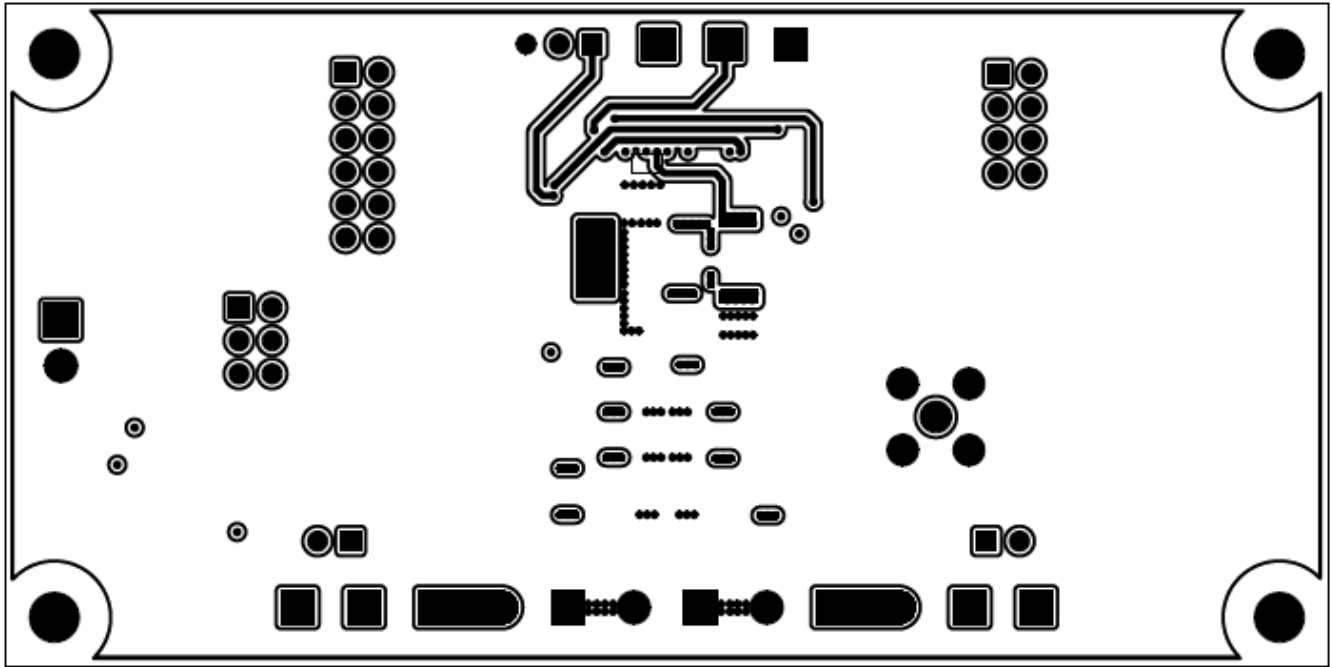

Figure 17. EVM Layer 5 Copper

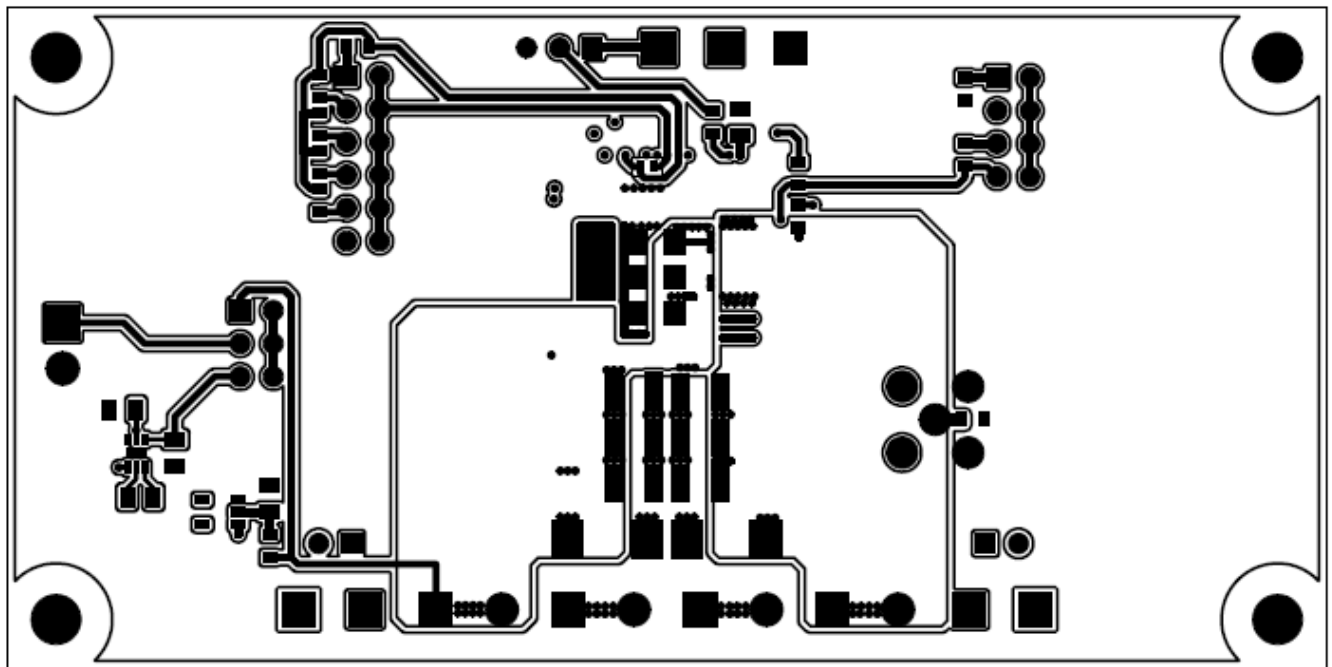

Figure 18. EVM Bottom Side Copper

## EVALUATION BOARD/KIT/MODULE (EVM) ADDITIONAL TERMS

Texas Instruments (TI) provides the enclosed Evaluation Board/Kit/Module (EVM) under the following conditions:

The user assumes all responsibility and liability for proper and safe handling of the goods. Further, the user indemnifies TI from all claims arising from the handling or use of the goods.

Should this evaluation board/kit not meet the specifications indicated in the User's Guide, the board/kit may be returned within 30 days from the date of delivery for a full refund. THE FOREGOING LIMITED WARRANTY IS THE EXCLUSIVE WARRANTY MADE BY SELLER TO BUYER AND IS IN LIEU OF ALL OTHER WARRANTIES, EXPRESSED, IMPLIED, OR STATUTORY, INCLUDING ANY WARRANTY OF MERCHANTABILITY OR FITNESS FOR ANY PARTICULAR PURPOSE. EXCEPT TO THE EXTENT OF THE INDEMNITY SET FORTH ABOVE, NEITHER PARTY SHALL BE LIABLE TO THE OTHER FOR ANY INDIRECT, SPECIAL, INCIDENTAL, OR CONSEQUENTIAL DAMAGES.

Please read the User's Guide and, specifically, the Warnings and Restrictions notice in the User's Guide prior to handling the product. This notice contains important safety information about temperatures and voltages. For additional information on TI's environmental and/or safety programs, please visit [www.ti.com/esh](http://www.ti.com/esh) or contact TI.

No license is granted under any patent right or other intellectual property right of TI covering or relating to any machine, process, or combination in which such TI products or services might be or are used. TI currently deals with a variety of customers for products, and therefore our arrangement with the user is not exclusive. TI assumes no liability for applications assistance, customer product design, software performance, or infringement of patents or services described herein.

## REGULATORY COMPLIANCE INFORMATION

As noted in the EVM User's Guide and/or EVM itself, this EVM and/or accompanying hardware may or may not be subject to the Federal Communications Commission (FCC) and Industry Canada (IC) rules.

For EVMs **not** subject to the above rules, this evaluation board/kit/module is intended for use for ENGINEERING DEVELOPMENT, DEMONSTRATION OR EVALUATION PURPOSES ONLY and is not considered by TI to be a finished end product fit for general consumer use. It generates, uses, and can radiate radio frequency energy and has not been tested for compliance with the limits of computing devices pursuant to part 15 of FCC or ICES-003 rules, which are designed to provide reasonable protection against radio frequency interference. Operation of the equipment may cause interference with radio communications, in which case the user at his own expense will be required to take whatever measures may be required to correct this interference.

### General Statement for EVMs including a radio

*User Power/Frequency Use Obligations:* This radio is intended for development/professional use only in legally allocated frequency and power limits. Any use of radio frequencies and/or power availability of this EVM and its development application(s) must comply with local laws governing radio spectrum allocation and power limits for this evaluation module. It is the user's sole responsibility to only operate this radio in legally acceptable frequency space and within legally mandated power limitations. Any exceptions to this are strictly prohibited and unauthorized by Texas Instruments unless user has obtained appropriate experimental/development licenses from local regulatory authorities, which is responsibility of user including its acceptable authorization.

### For EVMs annotated as FCC – FEDERAL COMMUNICATIONS COMMISSION Part 15 Compliant

#### Caution

This device complies with part 15 of the FCC Rules. Operation is subject to the following two conditions: (1) This device may not cause harmful interference, and (2) this device must accept any interference received, including interference that may cause undesired operation.

Changes or modifications not expressly approved by the party responsible for compliance could void the user's authority to operate the equipment.

### FCC Interference Statement for Class A EVM devices

This equipment has been tested and found to comply with the limits for a Class A digital device, pursuant to part 15 of the FCC Rules. These limits are designed to provide reasonable protection against harmful interference when the equipment is operated in a commercial environment. This equipment generates, uses, and can radiate radio frequency energy and, if not installed and used in accordance with the instruction manual, may cause harmful interference to radio communications. Operation of this equipment in a residential area is likely to cause harmful interference in which case the user will be required to correct the interference at his own expense.

### **FCC Interference Statement for Class B EVM devices**

This equipment has been tested and found to comply with the limits for a Class B digital device, pursuant to part 15 of the FCC Rules. These limits are designed to provide reasonable protection against harmful interference in a residential installation. This equipment generates, uses and can radiate radio frequency energy and, if not installed and used in accordance with the instructions, may cause harmful interference to radio communications. However, there is no guarantee that interference will not occur in a particular installation. If this equipment does cause harmful interference to radio or television reception, which can be determined by turning the equipment off and on, the user is encouraged to try to correct the interference by one or more of the following measures:

- Reorient or relocate the receiving antenna.
- Increase the separation between the equipment and receiver.
- Connect the equipment into an outlet on a circuit different from that to which the receiver is connected.
- Consult the dealer or an experienced radio/TV technician for help.

### **For EVMs annotated as IC – INDUSTRY CANADA Compliant**

This Class A or B digital apparatus complies with Canadian ICES-003.

Changes or modifications not expressly approved by the party responsible for compliance could void the user's authority to operate the equipment.

### **Concerning EVMs including radio transmitters**

This device complies with Industry Canada licence-exempt RSS standard(s). Operation is subject to the following two conditions: (1) this device may not cause interference, and (2) this device must accept any interference, including interference that may cause undesired operation of the device.

### **Concerning EVMs including detachable antennas**

Under Industry Canada regulations, this radio transmitter may only operate using an antenna of a type and maximum (or lesser) gain approved for the transmitter by Industry Canada. To reduce potential radio interference to other users, the antenna type and its gain should be so chosen that the equivalent isotropically radiated power (e.i.r.p.) is not more than that necessary for successful communication.

This radio transmitter has been approved by Industry Canada to operate with the antenna types listed in the user guide with the maximum permissible gain and required antenna impedance for each antenna type indicated. Antenna types not included in this list, having a gain greater than the maximum gain indicated for that type, are strictly prohibited for use with this device.

Cet appareil numérique de la classe A ou B est conforme à la norme NMB-003 du Canada.

Les changements ou les modifications pas expressément approuvés par la partie responsable de la conformité ont pu vider l'autorité de l'utilisateur pour actionner l'équipement.

### **Concernant les EVMs avec appareils radio**

Le présent appareil est conforme aux CNR d'Industrie Canada applicables aux appareils radio exempts de licence. L'exploitation est autorisée aux deux conditions suivantes : (1) l'appareil ne doit pas produire de brouillage, et (2) l'utilisateur de l'appareil doit accepter tout brouillage radioélectrique subi, même si le brouillage est susceptible d'en compromettre le fonctionnement.

### **Concernant les EVMs avec antennes détachables**

Conformément à la réglementation d'Industrie Canada, le présent émetteur radio peut fonctionner avec une antenne d'un type et d'un gain maximal (ou inférieur) approuvé pour l'émetteur par Industrie Canada. Dans le but de réduire les risques de brouillage radioélectrique à l'intention des autres utilisateurs, il faut choisir le type d'antenne et son gain de sorte que la puissance isotrope rayonnée équivalente (p.i.r.e.) ne dépasse pas l'intensité nécessaire à l'établissement d'une communication satisfaisante.

Le présent émetteur radio a été approuvé par Industrie Canada pour fonctionner avec les types d'antenne énumérés dans le manuel d'usage et ayant un gain admissible maximal et l'impédance requise pour chaque type d'antenne. Les types d'antenne non inclus dans cette liste, ou dont le gain est supérieur au gain maximal indiqué, sont strictement interdits pour l'exploitation de l'émetteur.

## **【Important Notice for Users of EVMs for RF Products in Japan】**

**This development kit is NOT certified as Confirming to Technical Regulations of Radio Law of Japan**

If you use this product in Japan, you are required by Radio Law of Japan to follow the instructions below with respect to this product:

1. Use this product in a shielded room or any other test facility as defined in the notification #173 issued by Ministry of Internal Affairs and Communications on March 28, 2006, based on Sub-section 1.1 of Article 6 of the Ministry's Rule for Enforcement of Radio Law of Japan,
2. Use this product only after you obtained the license of Test Radio Station as provided in Radio Law of Japan with respect to this product, or
3. Use of this product only after you obtained the Technical Regulations Conformity Certification as provided in Radio Law of Japan with respect to this product. Also, please do not transfer this product, unless you give the same notice above to the transferee. Please note that if you could not follow the instructions above, you will be subject to penalties of Radio Law of Japan.

**Texas Instruments Japan Limited**  
**(address) 24-1, Nishi-Shinjuku 6 chome, Shinjuku-ku, Tokyo, Japan**

<http://www.tij.co.jp>

### **【無線電波を送信する製品の開発キットをお使いになる際の注意事項】**

本開発キットは技術基準適合証明を受けておりません。

本製品のご使用に際しては、電波法遵守のため、以下のいずれかの措置を取っていただく必要がありますのでご注意ください。

1. 電波法施行規則第6条第1項第1号に基づく平成18年3月28日総務省告示第173号で定められた電波暗室等の試験設備でご使用いただく。
2. 実験局の免許を取得後ご使用いただく。
3. 技術基準適合証明を取得後ご使用いただく。

なお、本製品は、上記の「ご使用にあたっての注意」を譲渡先、移転先に通知しない限り、譲渡、移転できないものとします。

上記を遵守頂けない場合は、電波法の罰則が適用される可能性があることをご留意ください。

日本テキサス・インスツルメンツ株式会社  
東京都新宿区西新宿6丁目24番1号  
西新宿三井ビル

<http://www.tij.co.jp>



## **EVALUATION BOARD/KIT/MODULE (EVM) WARNINGS, RESTRICTIONS AND DISCLAIMERS**

**For Feasibility Evaluation Only, in Laboratory/Development Environments.** Unless otherwise indicated, this EVM is not a finished electrical equipment and not intended for consumer use. It is intended solely for use for preliminary feasibility evaluation in laboratory/development environments by technically qualified electronics experts who are familiar with the dangers and application risks associated with handling electrical mechanical components, systems and subsystems. It should not be used as all or part of a finished end product.

Your Sole Responsibility and Risk. You acknowledge, represent and agree that:

1. You have unique knowledge concerning Federal, State and local regulatory requirements (including but not limited to Food and Drug Administration regulations, if applicable) which relate to your products and which relate to your use (and/or that of your employees, affiliates, contractors or designees) of the EVM for evaluation, testing and other purposes.
2. You have full and exclusive responsibility to assure the safety and compliance of your products with all such laws and other applicable regulatory requirements, and also to assure the safety of any activities to be conducted by you and/or your employees, affiliates, contractors or designees, using the EVM. Further, you are responsible to assure that any interfaces (electronic and/or mechanical) between the EVM and any human body are designed with suitable isolation and means to safely limit accessible leakage currents to minimize the risk of electrical shock hazard.
3. Since the EVM is not a completed product, it may not meet all applicable regulatory and safety compliance standards (such as UL, CSA, VDE, CE, RoHS and WEEE) which may normally be associated with similar items. You assume full responsibility to determine and/or assure compliance with any such standards and related certifications as may be applicable. You will employ reasonable safeguards to ensure that your use of the EVM will not result in any property damage, injury or death, even if the EVM should fail to perform as described or expected.
4. You will take care of proper disposal and recycling of the EVM's electronic components and packing materials.

**Certain Instructions.** It is important to operate this EVM within TI's recommended specifications and environmental considerations per the user guidelines. Exceeding the specified EVM ratings (including but not limited to input and output voltage, current, power, and environmental ranges) may cause property damage, personal injury or death. If there are questions concerning these ratings please contact a TI field representative prior to connecting interface electronics including input power and intended loads. Any loads applied outside of the specified output range may result in unintended and/or inaccurate operation and/or possible permanent damage to the EVM and/or interface electronics. Please consult the EVM User's Guide prior to connecting any load to the EVM output. If there is uncertainty as to the load specification, please contact a TI field representative. During normal operation, some circuit components may have case temperatures greater than 60°C as long as the input and output are maintained at a normal ambient operating temperature. These components include but are not limited to linear regulators, switching transistors, pass transistors, and current sense resistors which can be identified using the EVM schematic located in the EVM User's Guide. When placing measurement probes near these devices during normal operation, please be aware that these devices may be very warm to the touch. As with all electronic evaluation tools, only qualified personnel knowledgeable in electronic measurement and diagnostics normally found in development environments should use these EVMs.

**Agreement to Defend, Indemnify and Hold Harmless.** You agree to defend, indemnify and hold TI, its licensors and their representatives harmless from and against any and all claims, damages, losses, expenses, costs and liabilities (collectively, "Claims") arising out of or in connection with any use of the EVM that is not in accordance with the terms of the agreement. This obligation shall apply whether Claims arise under law of tort or contract or any other legal theory, and even if the EVM fails to perform as described or expected.

**Safety-Critical or Life-Critical Applications.** If you intend to evaluate the components for possible use in safety critical applications (such as life support) where a failure of the TI product would reasonably be expected to cause severe personal injury or death, such as devices which are classified as FDA Class III or similar classification, then you must specifically notify TI of such intent and enter into a separate Assurance and Indemnity Agreement.

Mailing Address: Texas Instruments, Post Office Box 655303, Dallas, Texas 75265  
Copyright © 2013, Texas Instruments Incorporated

## IMPORTANT NOTICE

Texas Instruments Incorporated and its subsidiaries (TI) reserve the right to make corrections, enhancements, improvements and other changes to its semiconductor products and services per JESD46, latest issue, and to discontinue any product or service per JESD48, latest issue. Buyers should obtain the latest relevant information before placing orders and should verify that such information is current and complete. All semiconductor products (also referred to herein as "components") are sold subject to TI's terms and conditions of sale supplied at the time of order acknowledgment.

TI warrants performance of its components to the specifications applicable at the time of sale, in accordance with the warranty in TI's terms and conditions of sale of semiconductor products. Testing and other quality control techniques are used to the extent TI deems necessary to support this warranty. Except where mandated by applicable law, testing of all parameters of each component is not necessarily performed.

TI assumes no liability for applications assistance or the design of Buyers' products. Buyers are responsible for their products and applications using TI components. To minimize the risks associated with Buyers' products and applications, Buyers should provide adequate design and operating safeguards.

TI does not warrant or represent that any license, either express or implied, is granted under any patent right, copyright, mask work right, or other intellectual property right relating to any combination, machine, or process in which TI components or services are used. Information published by TI regarding third-party products or services does not constitute a license to use such products or services or a warranty or endorsement thereof. Use of such information may require a license from a third party under the patents or other intellectual property of the third party, or a license from TI under the patents or other intellectual property of TI.

Reproduction of significant portions of TI information in TI data books or data sheets is permissible only if reproduction is without alteration and is accompanied by all associated warranties, conditions, limitations, and notices. TI is not responsible or liable for such altered documentation. Information of third parties may be subject to additional restrictions.

Resale of TI components or services with statements different from or beyond the parameters stated by TI for that component or service voids all express and any implied warranties for the associated TI component or service and is an unfair and deceptive business practice. TI is not responsible or liable for any such statements.

Buyer acknowledges and agrees that it is solely responsible for compliance with all legal, regulatory and safety-related requirements concerning its products, and any use of TI components in its applications, notwithstanding any applications-related information or support that may be provided by TI. Buyer represents and agrees that it has all the necessary expertise to create and implement safeguards which anticipate dangerous consequences of failures, monitor failures and their consequences, lessen the likelihood of failures that might cause harm and take appropriate remedial actions. Buyer will fully indemnify TI and its representatives against any damages arising out of the use of any TI components in safety-critical applications.

In some cases, TI components may be promoted specifically to facilitate safety-related applications. With such components, TI's goal is to help enable customers to design and create their own end-product solutions that meet applicable functional safety standards and requirements. Nonetheless, such components are subject to these terms.

No TI components are authorized for use in FDA Class III (or similar life-critical medical equipment) unless authorized officers of the parties have executed a special agreement specifically governing such use.

Only those TI components which TI has specifically designated as military grade or "enhanced plastic" are designed and intended for use in military/aerospace applications or environments. Buyer acknowledges and agrees that any military or aerospace use of TI components which have **not** been so designated is solely at the Buyer's risk, and that Buyer is solely responsible for compliance with all legal and regulatory requirements in connection with such use.

TI has specifically designated certain components as meeting ISO/TS16949 requirements, mainly for automotive use. In any case of use of non-designated products, TI will not be responsible for any failure to meet ISO/TS16949.

### Products

Audio	<a href="http://www.ti.com/audio">www.ti.com/audio</a>
Amplifiers	<a href="http://amplifier.ti.com">amplifier.ti.com</a>
Data Converters	<a href="http://dataconverter.ti.com">dataconverter.ti.com</a>
DLP® Products	<a href="http://www.dlp.com">www.dlp.com</a>
DSP	<a href="http://dsp.ti.com">dsp.ti.com</a>
Clocks and Timers	<a href="http://www.ti.com/clocks">www.ti.com/clocks</a>
Interface	<a href="http://interface.ti.com">interface.ti.com</a>
Logic	<a href="http://logic.ti.com">logic.ti.com</a>
Power Mgmt	<a href="http://power.ti.com">power.ti.com</a>
Microcontrollers	<a href="http://microcontroller.ti.com">microcontroller.ti.com</a>
RFID	<a href="http://www.ti-rfid.com">www.ti-rfid.com</a>
OMAP Applications Processors	<a href="http://www.ti.com/omap">www.ti.com/omap</a>
Wireless Connectivity	<a href="http://www.ti.com/wirelessconnectivity">www.ti.com/wirelessconnectivity</a>

### Applications

Automotive and Transportation	<a href="http://www.ti.com/automotive">www.ti.com/automotive</a>
Communications and Telecom	<a href="http://www.ti.com/communications">www.ti.com/communications</a>
Computers and Peripherals	<a href="http://www.ti.com/computers">www.ti.com/computers</a>
Consumer Electronics	<a href="http://www.ti.com/consumer-apps">www.ti.com/consumer-apps</a>
Energy and Lighting	<a href="http://www.ti.com/energy">www.ti.com/energy</a>
Industrial	<a href="http://www.ti.com/industrial">www.ti.com/industrial</a>
Medical	<a href="http://www.ti.com/medical">www.ti.com/medical</a>
Security	<a href="http://www.ti.com/security">www.ti.com/security</a>
Space, Avionics and Defense	<a href="http://www.ti.com/space-avionics-defense">www.ti.com/space-avionics-defense</a>
Video and Imaging	<a href="http://www.ti.com/video">www.ti.com/video</a>

### TI E2E Community

[e2e.ti.com](http://e2e.ti.com)



## Стандарт Электрон Связь

Мы молодая и активно развивающаяся компания в области поставок электронных компонентов. Мы поставляем электронные компоненты отечественного и импортного производства напрямую от производителей и с крупнейших складов мира.

Благодаря сотрудничеству с мировыми поставщиками мы осуществляем комплексные и плановые поставки широчайшего спектра электронных компонентов.

Собственная эффективная логистика и склад в обеспечивает надежную поставку продукции в точно указанные сроки по всей России.

Мы осуществляем техническую поддержку нашим клиентам и предпродажную проверку качества продукции. На все поставляемые продукты мы предоставляем гарантию .

Осуществляем поставки продукции под контролем ВП МО РФ на предприятия военно-промышленного комплекса России , а также работаем в рамках 275 ФЗ с открытием отдельных счетов в уполномоченном банке. Система менеджмента качества компании соответствует требованиям ГОСТ ISO 9001.

Минимальные сроки поставки, гибкие цены, неограниченный ассортимент и индивидуальный подход к клиентам являются основой для выстраивания долгосрочного и эффективного сотрудничества с предприятиями радиоэлектронной промышленности, предприятиями ВПК и научно-исследовательскими институтами России.

С нами вы становитесь еще успешнее!

### Наши контакты:

**Телефон:** +7 812 627 14 35

**Электронная почта:** [sales@st-electron.ru](mailto:sales@st-electron.ru)

**Адрес:** 198099, Санкт-Петербург,  
Промышленная ул, дом № 19, литера Н,  
помещение 100-Н Офис 331