

AMPHENOL PART NUMBER CONFIGURATION
UE86-3G2620-X0X61

LIGHT PIPE OPTION

- 0 - NO LIGHT PIPE
- 1 - 4 LP PER 2X1, NORMAL ORIENTATION
- 2 - 2 INNER LP PER 2X1, NORMAL ORIENTATION
- 3 - 2 OUTER LP PER 2X1, NORMAL ORIENTATION
- 4 - 4 LP PER 2X1, REVERSING ORIENTATION
- 5 - 2 INNER LP PER 2X1, REVERSING ORIENTATION
- 6 - 2 OUTER LP PER 2X1, REVERSING ORIENTATION
- 7 - 3 LP PER 2X1, 2 OUTER LP, NORMAL ORIENTATION
- 8 - 3 LP PER 2X1, 2 OUTER LP, REVERSING ORIENTATION

PACKAGING

- 1 - TRAY PACKAGING (STACKED)

PLATING OPTIONS FOR CONNECTOR

- 2 - 30µ" GOLD PLATING ON MATING AREA
15-100µ" MATTE TIN ON TERMINATION
- 3 - 30µ" GOLD PLATING ON MATING AREA
150-300µ" MATTE TIN ON TERMINATION
- 5 - 15µ" GOLD PLATING ON MATING AREA
15-100µ" MATTE TIN ON TERMINATION
- 6 - 15µ" GOLD PLATING ON MATING AREA
150-300µ" MATTE TIN ON TERMINATION

PART NUMBER
 (LAST DIGIT INDICATING
 PACKAGING TYPE, NOT
 PRINTED ON THE PART)
 DATE CODE

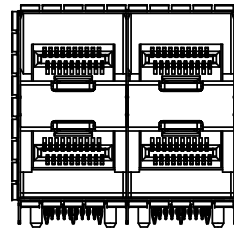
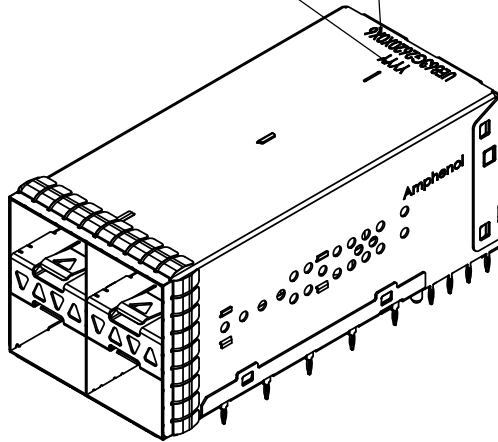

NO LIGHT PIPES
 UE86-3G2620-00X61

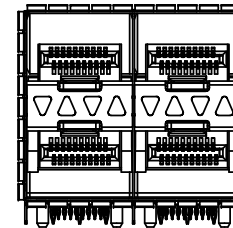

4 LIGHT PIPES
 UE86-3G2620-10X61

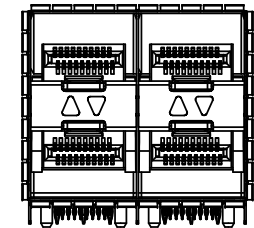

2 INNER LIGHT PIPES
 UE86-3G2620-20X61

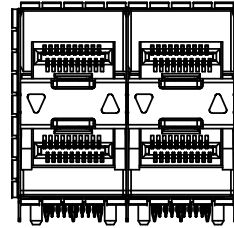

2 OUTER LIGHT PIPES
 UE86-3G2620-30X61

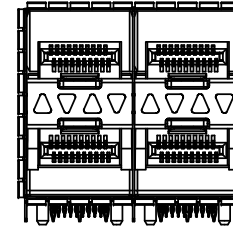

4 LIGHT PIPES UPSIDE DOWN
 UE86-3G2620-40X61

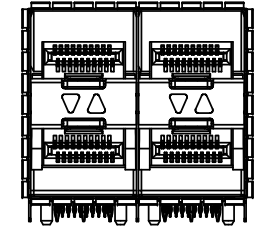

2 INNER LIGHT PIPES UPSIDE DOWN
 UE86-3G2620-50X61

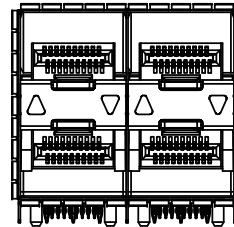

2 OUTER LIGHT PIPES UPSIDE DOWN
 UE86-3G2620-60X61

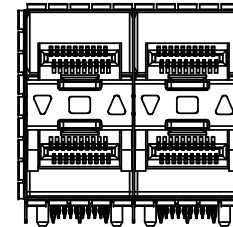

3 LIGHT PIPES
 UE86-3G2620-70X61

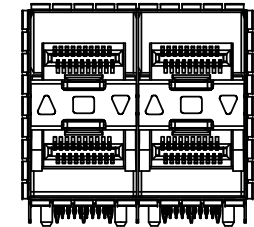

3 LIGHT PIPES UPSIDE DOWN
 UE86-3G2620-80X61

MATERIAL: (RoHS COMPLIANT)

- 1. CAGE - PRESS FIT: COPPER ALLOY (NICKEL SILVER)
- 2. CONNECTOR - PRESS FIT:
 -PLASTIC HOUSING: LCP, FLAMMABILITY RATING UL94-V0.
 -CONTACTS: PHOSPHOR BRONZE
- 3. LIGHT PIPE: CLEAR POLYCARBONATE, FLAMMABILITY RATING UL94-V0.
- 4. PACKAGING: TRAY PACKAGING.
- 5. TEMPERATURE RANGE: -40°C TO +85°C



REVISIONS				
REV.	ECN	DESCRIPTION	DATE	APPROVED
A		INITIAL RELEASE	10/02/2014	J.SI
B		UPDATE PLATING OPTIONS	JUN 25/14	J.SI
C		UPDATE NOTES	AUG 15/14	J.SI

THIS DOCUMENT CONTAINS PROPRIETARY INFORMATION AND SUCH INFORMATION MAY NOT BE DISCLOSED TO OTHERS FOR ANY PURPOSE OR USED FOR MANUFACTURING PURPOSES WITHOUT WRITTEN PERMISSION FROM AMPHENOL CANADA CORP.

UNLESS SPECIFIED OTHERWISE	DRAWN	P. OU	FEB10/14
DIMENSIONS ARE IN MILLIMETERS	CHECKED	J. SI	FEB 12/14
REFERENCE IN PARENTHESES	M.E. APP'D		
GENERAL TOLERANCES	Q.A. APP'D		
1 DECIMAL PLACE ±0.25	DWG APP'D	J. SI	FEB 12/14
2 DECIMAL PLACE ±0.15	MATERIAL AND FINISH	SEE NOTES	
3 DECIMAL PLACE ±0.10	REF.	ECN Exxxxx	
ANGULAR DEGREES ±1°	THIRD ANGLE PROJECTION	DO NOT SCALE DRAWING	
ENG. REL. NO.			

Amphenol High Speed Interconnects
 A Division of Amphenol Corp. www.amphenolcanada.com

2X2 SFP ULTRAPORT WITH LIGHT PIPE OPTIONS
 AND EMI SPRING FINGER

DWG. NO.	P-UE86-3G2620-X0X61	REV	C
CODE ID NO.	03554	DWG SIZE:	C
SCALE:	2:1	SHEET 1 OF 4	

REVISIONS				
REV.	ECN	DESCRIPTION	DATE	APPROVED
A		INITIAL RELEASE	10/02/2014	J. SI
B		UPDATE PLATING OPTIONS	JUN 25/14	J.SI
C		UPDATE NOTES	AUG 15/14	J.SI

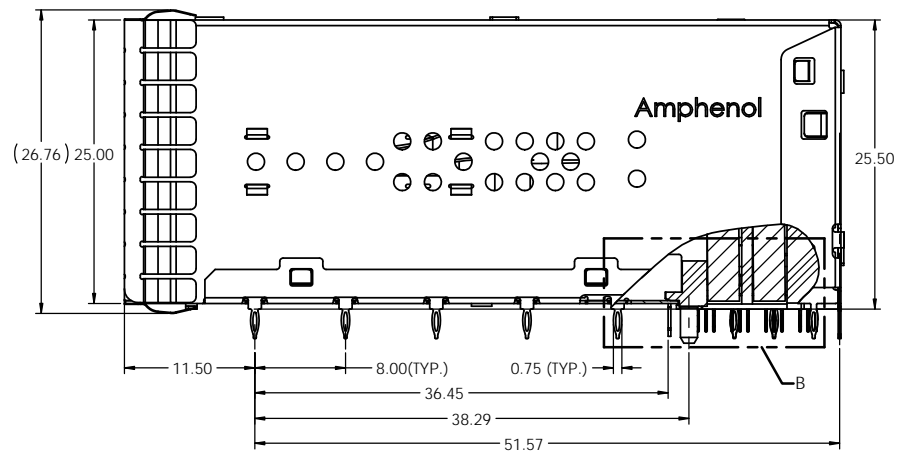
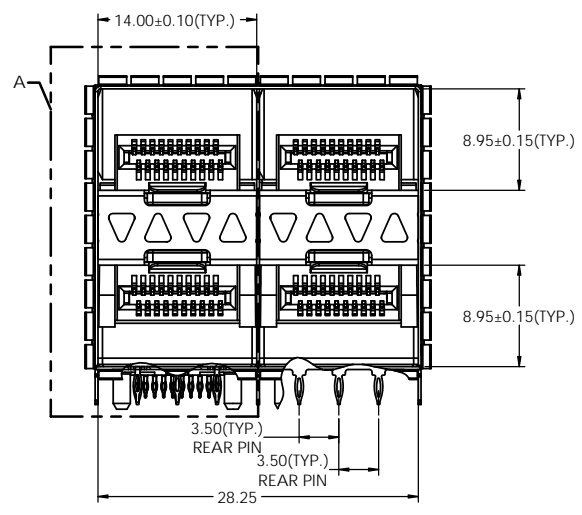
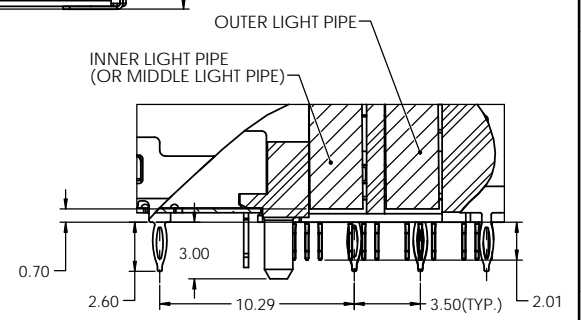
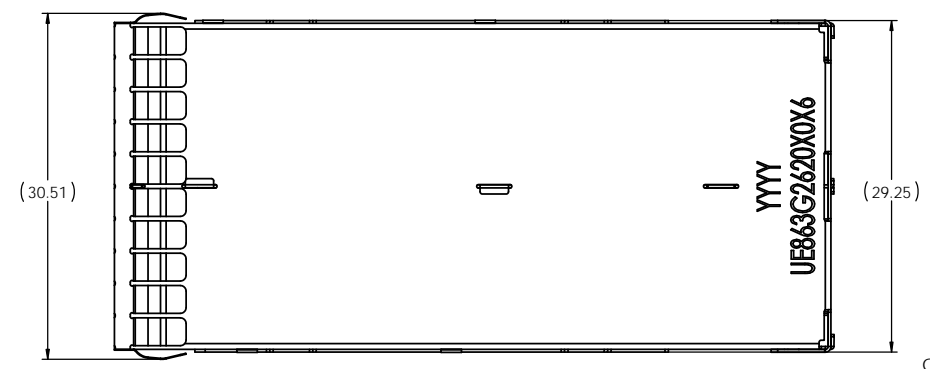
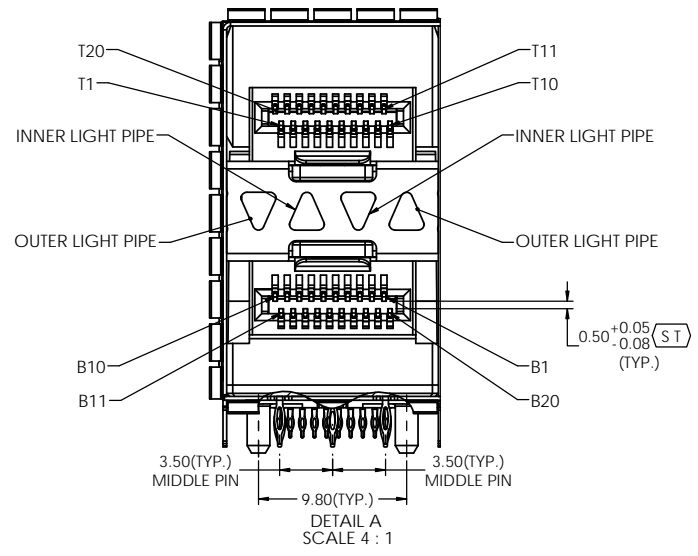

DETAIL B
SCALE 5 : 1

UNLESS SPECIFIED OTHERWISE	DRAWN	P. OU	FEB10/14
DIMENSIONS ARE IN MILLIMETERS	CHECKED	J. SI	FEB 12/14
REFERENCE IN PARENTHESES	M.E. APP'D		
GENERAL TOLERANCES	Q.A. APP'D		
1 DECIMAL PLACE ±0.25	DWG APP'D	J. SI	FEB 12/14
2 DECIMAL PLACE ±0.15	MATERIAL AND FINISH	SEE NOTES	
3 DECIMAL PLACE ±0.10	REF.	ECN Exxxxx	
ANGULAR DEGREES ±1°	THIRD ANGLE PROJECTION	DO NOT SCALE DRAWING	
ENG. REL. NO.			

Amphenol High Speed Interconnects
 A Division of Amphenol Corp. www.amphenolcanada.com

2X2 SFP ULTRAPORT WITH LIGHT PIPE OPTIONS
 AND EMI SPRING FINGER

DWG. NO. P-UE86-3G2620-X0X61 REV C

CODE ID NO. 03554 DWG SIZE: C SCALE: 3:1 SHEET 2 OF 4

THIS DOCUMENT CONTAINS PROPRIETARY INFORMATION AND SUCH INFORMATION MAY NOT BE DISCLOSED TO OTHERS FOR ANY PURPOSE OR USED FOR MANUFACTURING PURPOSES WITHOUT WRITTEN PERMISSION FROM AMPHENOL CANADA CORP.

REVISIONS				
REV.	ECN	DESCRIPTION	DATE	APPROVED
A		INITIAL RELEASE	10/02/2014	J. SI
B		UPDATE PLATING OPTIONS	JUN 25/14	J.SI
C		UPDATE NOTES	AUG 15/14	J.SI

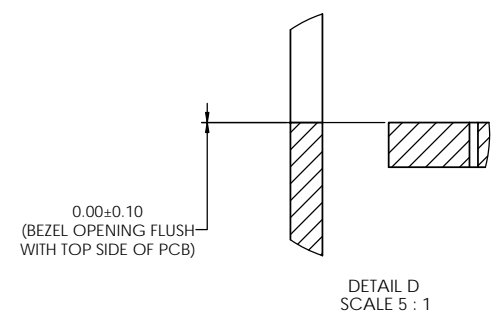
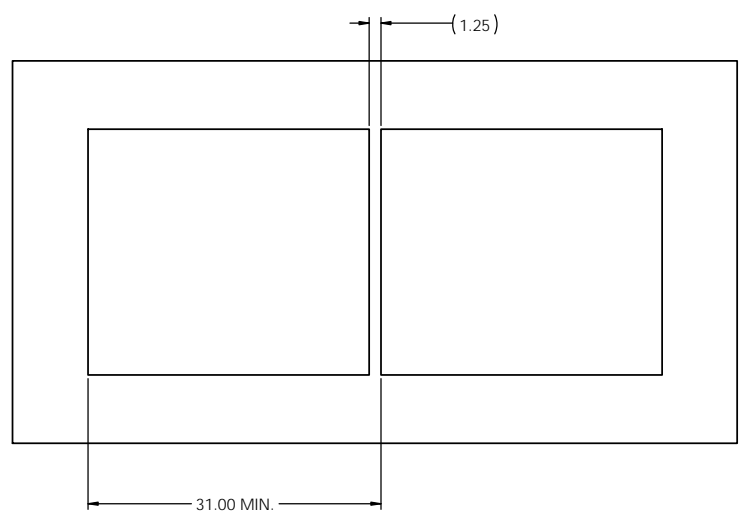
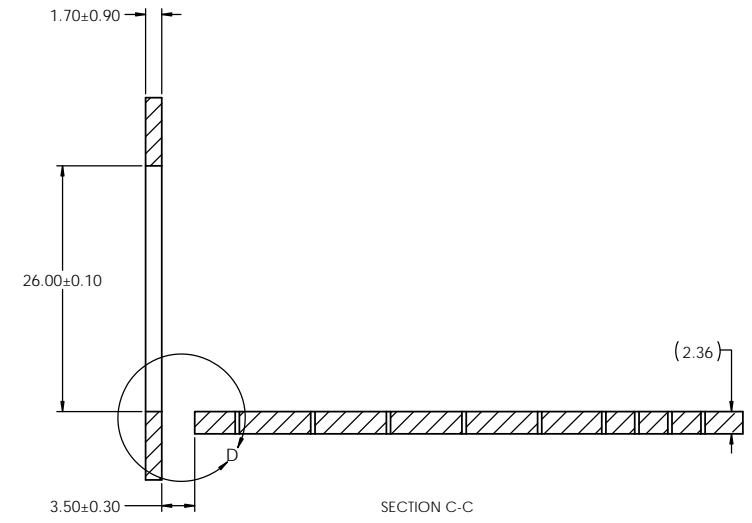
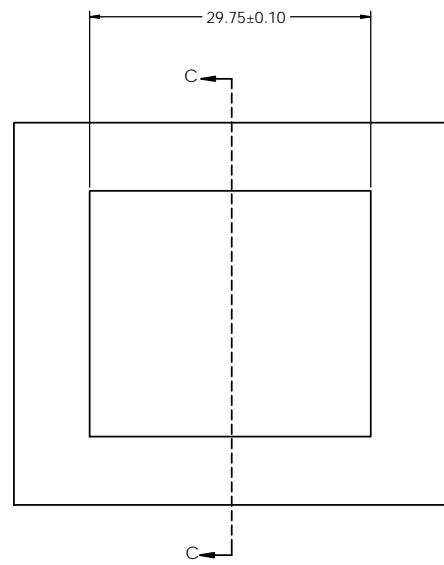

THIS DOCUMENT CONTAINS PROPRIETARY INFORMATION AND SUCH INFORMATION MAY NOT BE DISCLOSED TO OTHERS FOR ANY PURPOSE OR USED FOR MANUFACTURING PURPOSES WITHOUT WRITTEN PERMISSION FROM AMPHENOL CANADA CORP.

UNLESS SPECIFIED OTHERWISE	DRAWN	P. OU	FEB10/14
DIMENSIONS ARE IN MILLIMETERS	CHECKED	J. SI	FEB 12/14
REFERENCE IN PARENTHESES	M.E. APP'D		
GENERAL TOLERANCES	Q.A. APP'D		
1 DECIMAL PLACE ±0.25	DWG APP'D	J. SI	FEB 12/14
2 DECIMAL PLACE ±0.15	MATERIAL AND FINISH	SEE NOTES	
3 DECIMAL PLACE ±0.10	REF.	ECN Exxxxx	
ANGULAR DEGREES ±1°	THIRD ANGLE PROJECTION		
ENG. REL. NO.		DO NOT SCALE DRAWING	

Amphenol High Speed Interconnects
 A Division of Amphenol Corp. www.amphenolcanada.com

2X2 SFP ULTRAPORT WITH LIGHT PIPE OPTIONS AND EMI SPRING FINGER

DWG. NO. P-UE86-3G2620-X0X61

CODE ID NO. 03554 | DWG SIZE: C | SCALE: 2.5:1 | SHEET 3 OF 4



Стандарт Электрон Связь

Мы молодая и активно развивающаяся компания в области поставок электронных компонентов. Мы поставляем электронные компоненты отечественного и импортного производства напрямую от производителей и с крупнейших складов мира.

Благодаря сотрудничеству с мировыми поставщиками мы осуществляем комплексные и плановые поставки широчайшего спектра электронных компонентов.

Собственная эффективная логистика и склад в обеспечивает надежную поставку продукции в точно указанные сроки по всей России.

Мы осуществляем техническую поддержку нашим клиентам и предпродажную проверку качества продукции. На все поставляемые продукты мы предоставляем гарантию .

Осуществляем поставки продукции под контролем ВП МО РФ на предприятия военно-промышленного комплекса России , а также работаем в рамках 275 ФЗ с открытием отдельных счетов в уполномоченном банке. Система менеджмента качества компании соответствует требованиям ГОСТ ISO 9001.

Минимальные сроки поставки, гибкие цены, неограниченный ассортимент и индивидуальный подход к клиентам являются основой для выстраивания долгосрочного и эффективного сотрудничества с предприятиями радиоэлектронной промышленности, предприятиями ВПК и научно-исследовательскими институтами России.

С нами вы становитесь еще успешнее!

Наши контакты:

Телефон: +7 812 627 14 35

Электронная почта: sales@st-electron.ru

Адрес: 198099, Санкт-Петербург,
Промышленная ул, дом № 19, литера Н,
помещение 100-Н Офис 331