

**DESCRIPTION**

The UC184xA family of control ICs provides all the necessary features to implement off-line fixed-frequency, current-mode switching power supplies with a minimum of external components. The current mode architecture demonstrates improved load regulation, pulse-by-pulse current limiting and inherent protection of the power supply output switch. The IC includes: A bandgap reference trimmed to  $\pm 1\%$  accuracy, an error amplifier, a current sense comparator with internal clamp to 1V, a high current totem pole output stage for fast switching of power

MOSFET's, and an externally programmable oscillator to set frequency and maximum duty cycle. The under-voltage lock-out is designed to operate with 250 $\mu$ A typ. start-up current, allowing an efficient bootstrap supply voltage design. Available options for this family of products, such as start-up voltage hysteresis and duty cycle, are summarized below in the Available Options section. The UC184xA family of control ICs is also available in 14-pin SOIC package which makes the Power Output Stage Collector and Ground pins available.

**KEY FEATURES**

- **LOW START-UP CURRENT.** (0.5mA max.)
- **TRIMMED OSCILLATOR DISCHARGE CURRENT.** (See Product Highlight)
- OPTIMIZED FOR OFF-LINE AND DC-TO-DC CONVERTERS.
- AUTOMATIC FEED FORWARD COMPENSATION.
- PULSE-BY-PULSE CURRENT LIMITING.
- ENHANCED LOAD RESPONSE CHARACTERISTICS.
- UNDER-VOLTAGE LOCKOUT WITH HYSTERESIS.
- DOUBLE PULSE SUPPRESSION.
- HIGH-CURRENT TOTEM POLE OUTPUT.
- INTERNALLY TRIMMED BANDGAP REFERENCE.
- 500KHz OPERATION.
- LOW  $R_{\theta}$  ERROR AMPLIFIER.

**PRODUCT HIGHLIGHT**

COMPARISON OF UC384xA VS. SG384X DISCHARGE CURRENT

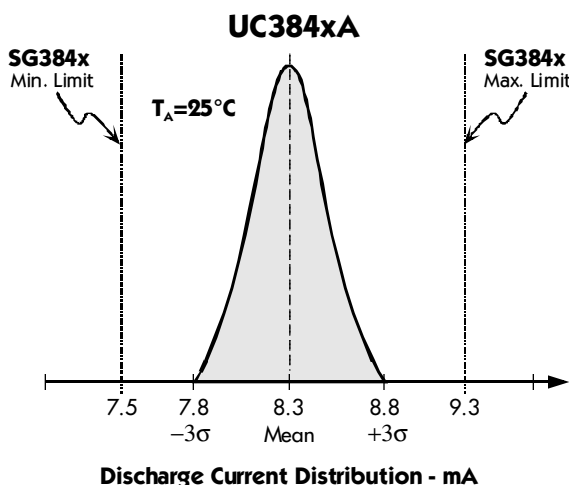

**APPLICATIONS**

- ECONOMICAL OFF-LINE FLYBACK OR FORWARD CONVERTERS.
- DC-DC BUCK OR BOOST CONVERTERS.
- LOW COST DC MOTOR CONTROL.

AVAILABLE OPTIONS

Part #	Start-Up Voltage	Hysteresis	Max. Duty Cycle
UCx842A	16V	6V	<100%
UCx843A	8.4V	0.8V	<100%
UCx844A	16V	6V	<50%
UCx845A	8.4V	0.8V	<50%

**PACKAGE ORDER INFORMATION**

$T_A$ (°C)	<b>M</b> Plastic DIP 8-pin	<b>DM</b> Plastic SOIC 8-pin	<b>D</b> Plastic SOIC 14-pin	<b>Y</b> Ceramic DIP 8-pin
0 to 70	UC384xAM	UC384xADM	UC384xAD	—
-40 to 85	UC284xAM	UC284xADM	UC284xAD	UC284xAAY
-55 to 125	—	—	—	UC184xAAY

Note: All surface-mount packages are available in Tape & Reel. Append the letter "T" to part number. (i.e. UC3842ADMT)

FOR FURTHER INFORMATION CALL (714) 898-8121

11861 WESTERN AVENUE, GARDEN GROVE, CA. 92841

# UC184xA/284xA/384xA

## CURRENT MODE PWM CONTROLLER

### PRODUCTION DATA SHEET

#### ABSOLUTE MAXIMUM RATINGS (Note 1)

Supply Voltage (Low Impedance Source) ( $V_{CC}$ )	30V
Supply Voltage ( $I_{CC} < 30mA$ )	Self Limiting
Output Current	$\pm 1A$
Output Energy (Capacitive Load)	5 $\mu$ J
Analog Inputs ( $V_{FB}$ & $I_{SENSE}$ )	-0.3V to +6.3V
Error Amp Output Sink Current	10mA
Power Dissipation at $T_A = 25^\circ C$ (M Package)	1W
Storage Temperature Range	-65°C to +150°C
Lead Temperature (Soldering, 10 Seconds)	300°C

Note 1. Exceeding these ratings could cause damage to the device. All voltages are with respect to Ground. Currents are positive into, negative out of the specified terminal. Pin numbers refer to DIL packages only.

#### THERMAL DATA

##### M PACKAGE:

THERMAL RESISTANCE-JUNCTION TO AMBIENT, $\theta_{JA}$	95°C/W
---	--------

##### DM PACKAGE:

THERMAL RESISTANCE-JUNCTION TO AMBIENT, $\theta_{JA}$	165°C/W
---	---------

##### D PACKAGE:

THERMAL RESISTANCE-JUNCTION TO AMBIENT, $\theta_{JA}$	120°C/W
---	---------

##### Y PACKAGE:

THERMAL RESISTANCE-JUNCTION TO AMBIENT, $\theta_{JA}$	130°C/W
---	---------

Junction Temperature Calculation:  $T_J = T_A + (P_D \times \theta_{JA})$ .

The  $\theta_{JA}$  numbers are guidelines for the thermal performance of the device/pc-board system.

All of the above assume no ambient airflow

#### PACKAGE PIN OUTS

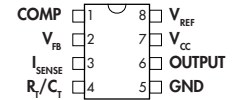

M & Y PACKAGE  
(Top View)

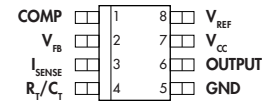

DM PACKAGE  
(Top View)

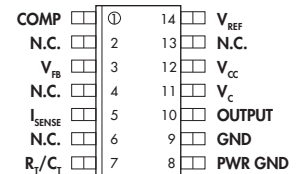

D PACKAGE  
(Top View)

## CURRENT MODE PWM CONTROLLER

### PRODUCTION DATA SHEET

#### ELECTRICAL CHARACTERISTICS

(Unless otherwise specified, these specifications apply over the operating ambient temperatures for UC384xA with  $0^{\circ}\text{C} \leq T_A \leq 70^{\circ}\text{C}$ , UC284xA with  $-40^{\circ}\text{C} \leq T_A \leq 85^{\circ}\text{C}$ , UC184xA with  $-55^{\circ}\text{C} \leq T_A \leq 125^{\circ}\text{C}$ ;  $V_{CC}=15\text{V}$ ;  $R_T=10\text{K}$ ;  $C_T=3.3\text{nF}$ . Low duty cycle pulse testing techniques are used which maintains junction and case temperatures equal to the ambient temperature.)

Parameter	Symbol	Test Conditions	UC184xA/284xA			UC384xA			Units
			Min.	Typ.	Max.	Min.	Typ.	Max.	
<b>Reference Section</b>									
Output Voltage	$V_{REF}$	$T_J = 25^{\circ}\text{C}, I_L = 1\text{mA}$	4.95	5.00	5.05	4.90	5.00	5.10	V
Line Regulation		$12 \leq V_{IN} \leq 25\text{V}$		6	20		6	20	mV
Load Regulation		$1 \leq I_O \leq 20\text{mA}$		6	25		6	25	mV
Temperature Stability (Note 2 & 7)				0.2	0.4		0.2	0.4	mV/ $^{\circ}\text{C}$
Total Output Variation		Over Line, Load, and Temperature	4.9		5.1	4.82		5.18	V
Output Noise Voltage (Note 2)	$V_N$	$10\text{Hz} \leq f \leq 10\text{kHz}, T_J = 25^{\circ}\text{C}$		50			50		$\mu\text{V}$
Long Term Stability (Note 2)		$T_A = 125^{\circ}\text{C}, t = 1000\text{hrs}$		5	25		5	25	mV
Output Short Circuit Current	$I_{SC}$		-30	-100	-180	-30	-100	-180	mA
<b>Oscillator Section</b>									
Initial Accuracy (Note 6)		$T_J = 25^{\circ}\text{C}$	47	52	57	47	52	57	kHz
Voltage Stability		$12 \leq V_{CC} \leq 25\text{V}$		0.2	1		0.2	1	%
Temperature Stability (Note 2)		$T_{MIN} \leq T_A \leq T_{MAX}$		5			5		%
Amplitude (Note 2)				1.7			1.7		V
Discharge Current		$T_J = 25^{\circ}\text{C}, V_{PIN4} = 2\text{V}$	7.8	8.3	8.8	7.8	8.3	8.8	mA
		$V_{PIN4} = 2\text{V}, T_{MIN} \leq T_A \leq T_{MAX}$	7.5		8.8	7.6		8.8	mA
<b>Error Amp Section</b>									
Input Voltage		$V_{PIN1} = 2.5\text{V}$	2.45	2.50	2.55	2.42	2.50	2.58	V
Input Bias Current	$I_B$			-0.3	-1		-0.3	-2	$\mu\text{A}$
Open Loop Gain	$A_{VOL}$	$2 \leq V_O \leq 4\text{V}$	65	90		65	90		dB
Unity Gain Bandwidth (Note 2)	UGBW	$T_J = 25^{\circ}\text{C}$	0.7	1		0.7	1		MHz
Power Supply Rejection Ratio (Note 3)	PSRR	$12 \leq V_{CC} \leq 25\text{V}$	60	70		60	70		dB
Output Sink Current	$I_{OL}$	$V_{PIN2} = 2.7\text{V}, V_{PIN1} = 1.1\text{V}$	2	6		2	6		mA
Output Source Current	$I_{OH}$	$V_{PIN2} = 2.3\text{V}, V_{PIN1} = 5\text{V}$	-0.5	-0.8		-0.5	-0.8		mA
Output Voltage High Level	$V_{OH}$	$V_{PIN2} = 2.3\text{V}, R_L = 15\text{K to ground}$	5	6		5	6		V
Output Voltage Low Level	$V_{OL}$	$V_{PIN2} = 2.7\text{V}, R_L = 15\text{K to } V_{REF}$		0.7	1.1		0.7	1.1	V
<b>Current Sense Section</b>									
Gain (Note 3 & 4)	$A_{VOL}$		2.85	3	3.15	2.85	3	3.15	V/V
Maximum Input Signal (Note 3)		$V_{PIN1} = 5\text{V}$	0.9	1	1.1	0.9	1	1.1	V
Power Supply Rejection Ratio (Note 3)	PSRR	$12 \leq V_{CC} \leq 25\text{V}$		70			70		dB
Input Bias Current	$I_B$			-2	-10		-2	-10	$\mu\text{A}$
Delay to Output (Note 2)	$T_{pd}$	$V_{PIN3} = 0 \text{ to } 2\text{V}$		150	300		150	300	ns
<b>Output Section</b>									
Output Low Level	$V_{OL}$	$I_{SINK} = 20\text{mA}$		0.1	0.4		0.1	0.4	V
		$I_{SINK} = 200\text{mA}$		1.5	2.2		1.5	2.2	V
Output High Level	$V_{OH}$	$I_{SOURCE} = 20\text{mA}$	13	13.5		13	13.5		V
		$I_{SOURCE} = 200\text{mA}$	12	13.5		12	13.5		V
Rise Time (Note 2)	$T_R$	$T_J = 25^{\circ}\text{C}, C_L = 1\text{nF}$		50	150		50	150	ns
Fall Time (Note 2)	$T_F$	$T_J = 25^{\circ}\text{C}, C_L = 1\text{nF}$		50	150		50	150	ns
UVLO Saturation	$V_{SAT}$	$V_{CC} = 5\text{V}, I_{SINK} = 10\text{mA}$		0.7	1.2		0.7	1.2	V

(Electrical Characteristics continue next page.)

# UC184xA/284xA/384xA

## CURRENT MODE PWM CONTROLLER

### PRODUCTION DATA SHEET

#### ELECTRICAL CHARACTERISTICS (Con't.)

Parameter	Symbol	Test Conditions	UC184xA/284xA			UC384xA			Units
			Min.	Typ.	Max.	Min.	Typ.	Max.	
<b>Under-Voltage Lockout Section</b>									
Start Threshold		x842A/4A	15	16	17	14.5	16	17.5	V
		x843A/5A	7.8	8.4	9.0	7.8	8.4	9.0	V
Min. Operation Voltage After Turn-On		x842A/4A	9	10	11	8.5	10	11.5	V
		x843A/5A	7.0	7.6	8.2	7.0	7.6	8.2	V
<b>PWM Section</b>									
Maximum Duty Cycle		x842A/3A	94	96	100	94	96	100	%
		x844A/5A	47	48	50	47	48	50	%
Minimum Duty Cycle					0			0	%
<b>Total Standby Section</b>									
Start-Up Current				0.3	0.5		0.3	0.5	mA
Operating Supply Current	$I_{CC}$			11	17		11	17	mA
Zener Voltage	$V_Z$	$I_{CC} = 25\text{mA}$	30	35		30	35		V

Notes: 2. These parameters, although guaranteed, are not 100% tested in production.

3. Parameter measured at trip point of latch with  $V_{VFB} = 0$ .

4. Gain defined as:  $A_{VOL} = \frac{\Delta V_{COMP}}{\Delta V_{ISENSE}}$ ;  $0 \leq V_{ISENSE} \leq 0.8\text{V}$ .

5. Adjust  $V_{CC}$  above the start threshold before setting at 15V.

6. Output frequency equals oscillator frequency for the UC1842A and UC1843A. Output frequency is one half oscillator frequency for the UC1844A and UC1845A.

7. "Temperature stability, sometimes referred to as average temperature coefficient, is described by the equation:

$$\text{Temp Stability} = \frac{V_{REF}(\text{max.}) - V_{REF}(\text{min.})}{T_J(\text{max.}) - T_J(\text{min.})}$$

$V_{REF}(\text{max.})$  &  $V_{REF}(\text{min.})$  are the maximum & minimum reference voltage measured over the appropriate temperature range. Note that the extremes in voltage do not necessarily occur at the extremes in temperature."

#### BLOCK DIAGRAM

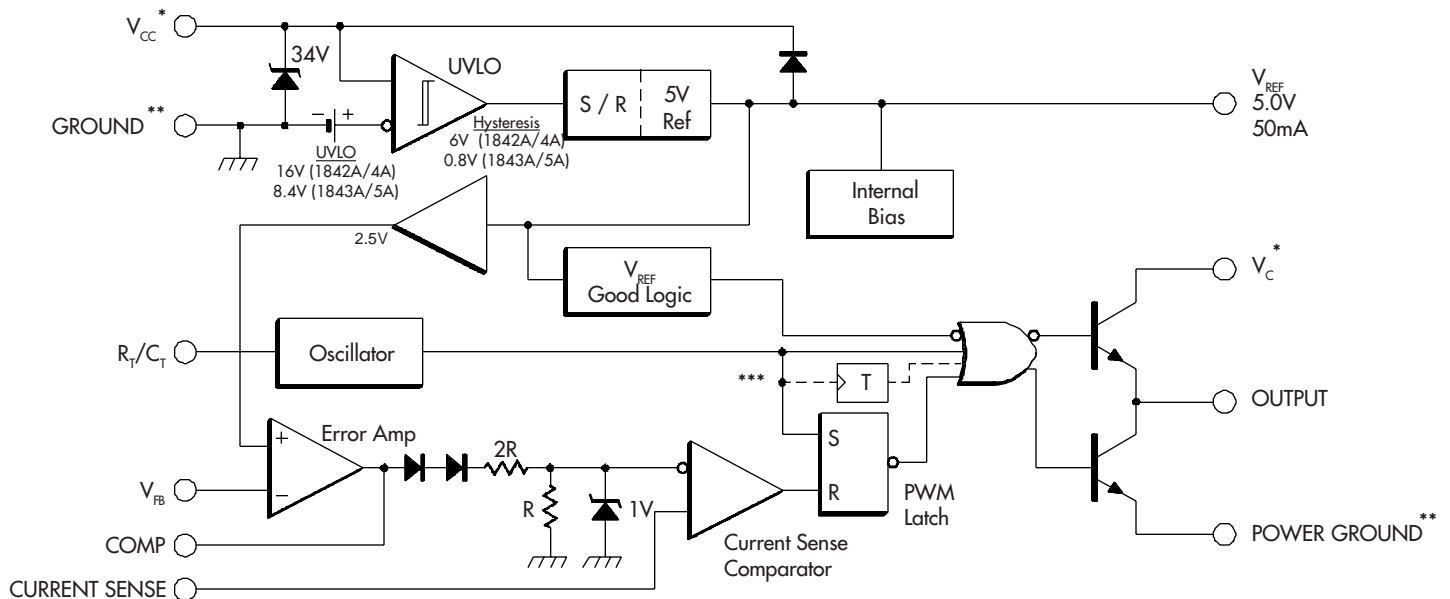

\* -  $V_{CC}$  and  $V_c$  are internally connected for 8 pin packages.

\*\* - POWER GROUND and GROUND are internally connected for 8 pin packages.

\*\*\* - Toggle flip flop used only in x844A and x845A series.

CURRENT MODE PWM CONTROLLER

PRODUCTION DATA SHEET

CHARACTERISTIC CURVES

FIGURE 1. — OSCILLATOR FREQUENCY vs. TIMING RESISTOR

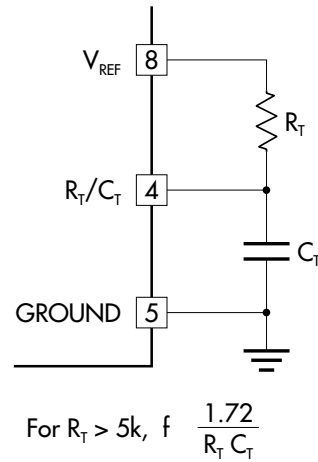
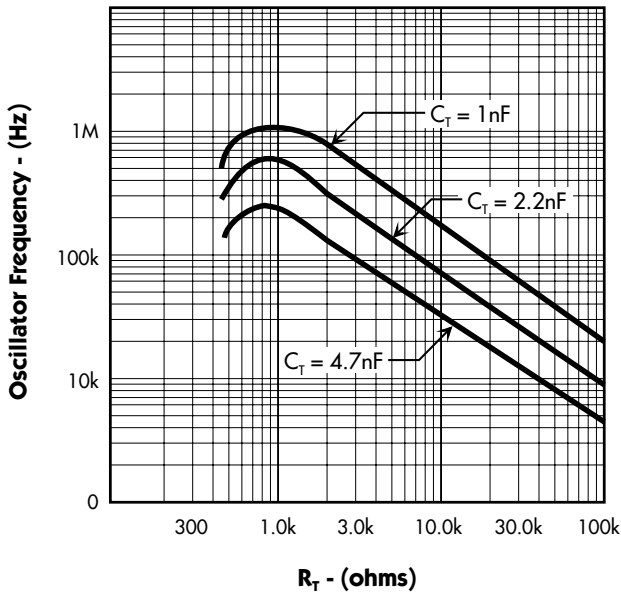

Note: Output drive frequency is half the oscillator frequency for the UCx844A/5A devices.

FIGURE 2. — MAXIMUM DUTY CYCLE vs. TIMING RESISTOR

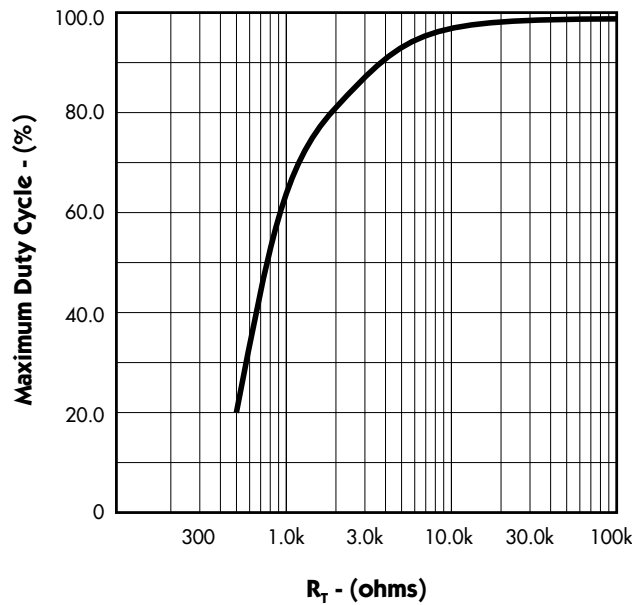

#### TYPICAL APPLICATION CIRCUITS

**FIGURE 3. — CURRENT SENSE SPIKE SUPPRESSION**

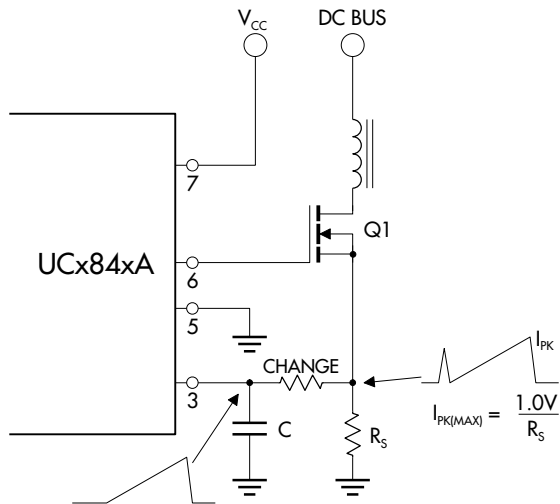

The RC low pass filter will eliminate the leading edge current spike caused by parasitics of Power MOSFET.

**FIGURE 4. — MOSFET PARASITIC OSCILLATIONS**

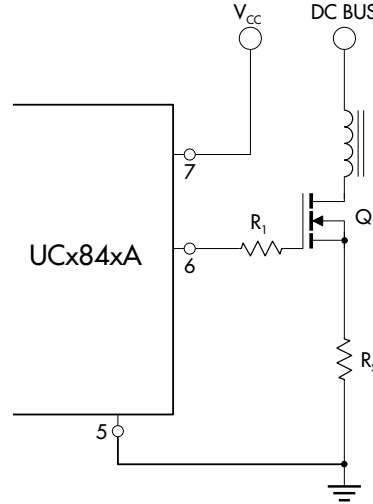

A resistor ( $R_1$ ) in series with the MOSFET gate will reduce overshoot & ringing caused by the MOSFET input capacitance and any inductance in series with the gate drive. (Note: It is very important to have a low inductance ground path to insure correct operation of the I.C. This can be done by making the ground paths as short and as wide as possible.)

**FIGURE 5. — EXTERNAL DUTY CYCLE CLAMP AND MULTI-UNIT SYNCHRONIZATION**

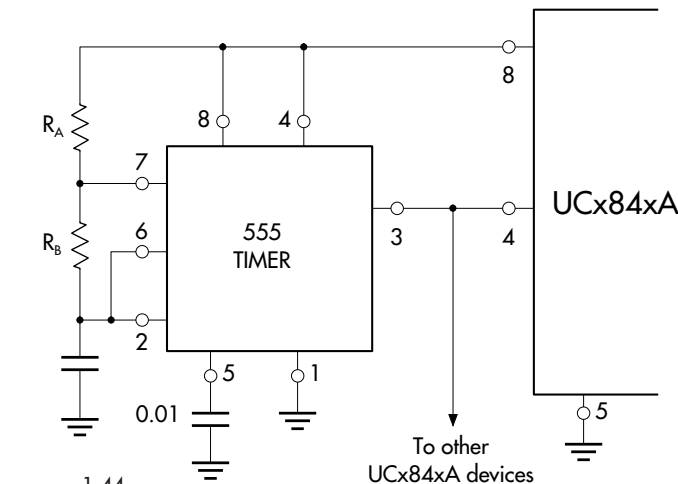

$$f = \frac{1.44}{(R_A + 2R_B)C}$$

$$f = \frac{R_B}{R_A + 2R_B}$$

Precision duty cycle limiting as well as synchronizing several parts is possible with the above circuitry.

## CURRENT MODE PWM CONTROLLER

### PRODUCTION DATA SHEET

#### TYPICAL APPLICATION CIRCUITS (continued)

FIGURE 6. — SLOPE COMPENSATION

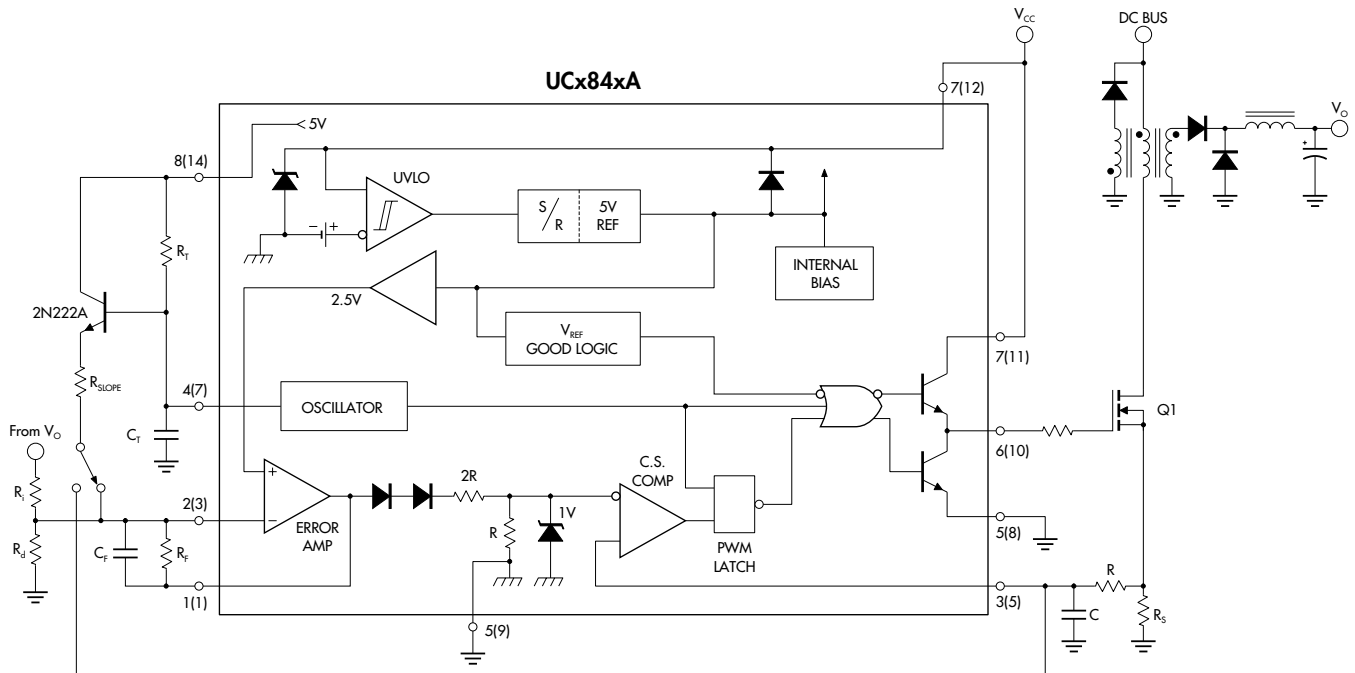

Due to inherent instability of current mode converters running above 50% duty cycle, slope compensation should be added to either the current sense pin or the error amplifier. Figure 6 shows a typical slope compensation technique.

FIGURE 7. — OPEN LOOP LABORATORY FIXTURE

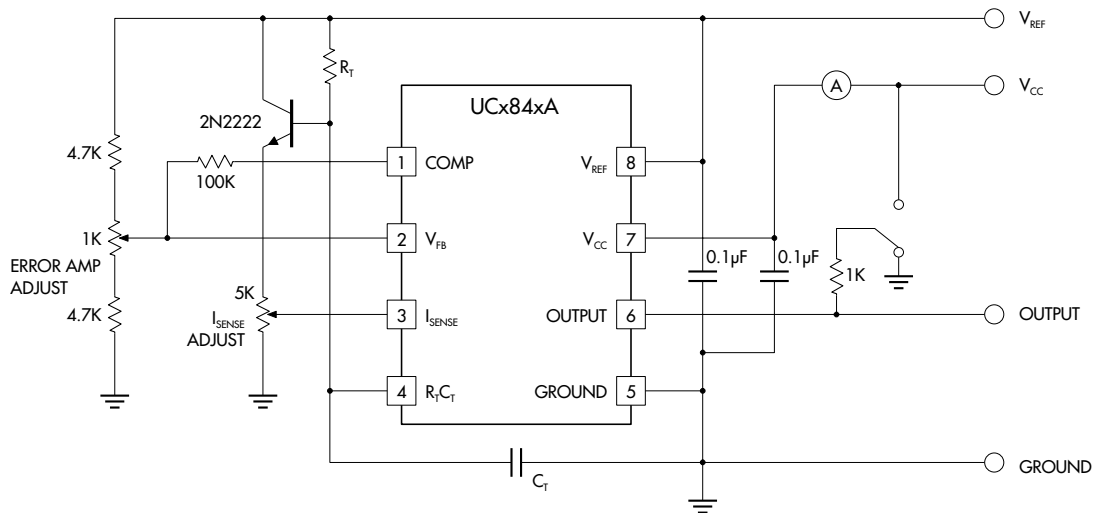

High peak currents associated with capacitive loads necessitate careful grounding techniques. Timing and bypass capacitors should be connected to pin 5 in a single point ground. The transistor and 5k potentiometer are used to sample the oscillator waveform and apply an adjustable ramp to pin 3.

# UC184xA/284xA/384xA

## CURRENT MODE PWM CONTROLLER

### PRODUCTION DATA SHEET

#### TYPICAL APPLICATION CIRCUITS (continued)

FIGURE 8. — OFF-LINE FLYBACK REGULATOR

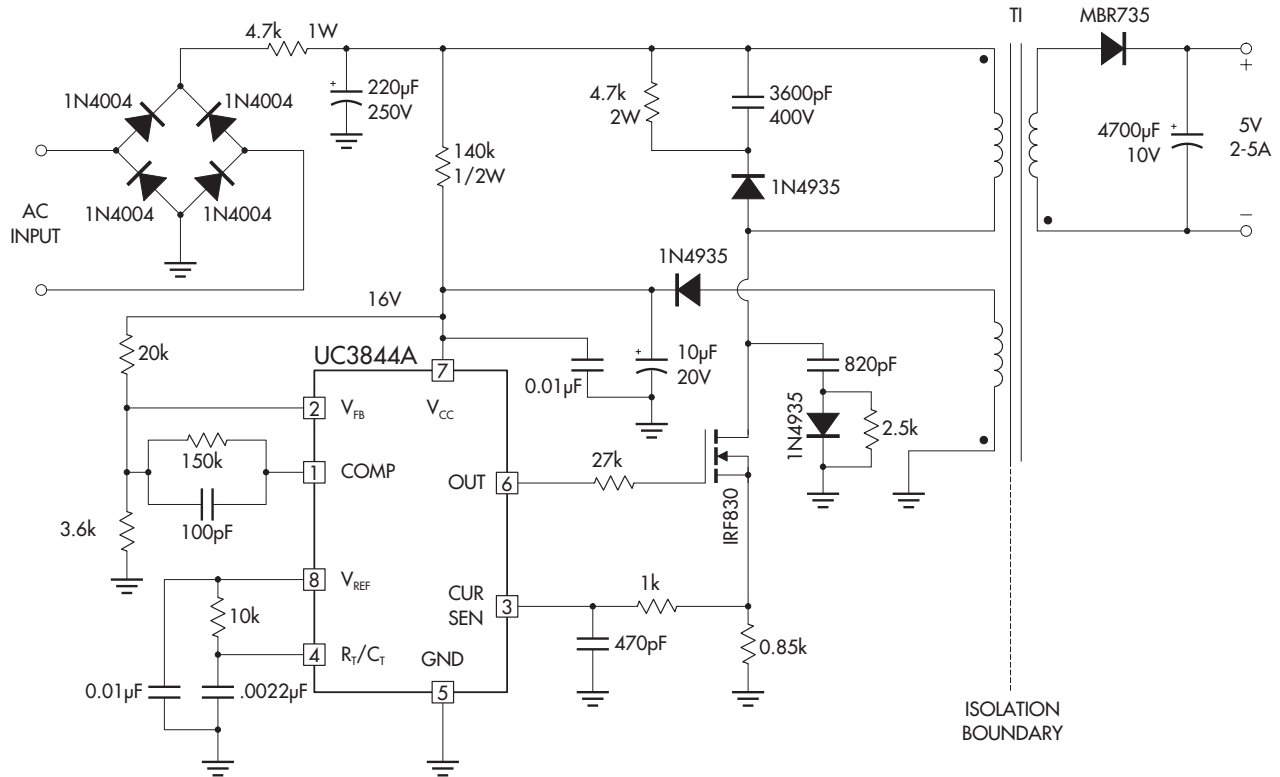

#### SPECIFICATIONS

Input line voltage:	90VAC to 130VAC
Input frequency:	50 or 60Hz
Switching frequency:	40KHz $\pm$ 10%
Output power:	25W maximum
Output voltage:	5V $\pm$ 5%
Output current:	2 to 5A
Line regulation:	0.01%/V
Load regulation:	8%/A*
Efficiency @ 25 Watts,	
$V_{IN} = 90VAC$ :	70%
$V_{IN} = 130VAC$ :	65%
Output short-circuit current:	2.5Amp average

\* This circuit uses a low-cost feedback scheme in which the DC voltage developed from the primary-side control winding is sensed by the UC3844A error amplifier. Load regulation is therefore dependent on the coupling between secondary and control windings, and on transformer leakage inductance.





## Стандарт Электрон Связь

Мы молодая и активно развивающаяся компания в области поставок электронных компонентов. Мы поставляем электронные компоненты отечественного и импортного производства напрямую от производителей и с крупнейших складов мира.

Благодаря сотрудничеству с мировыми поставщиками мы осуществляем комплексные и плановые поставки широчайшего спектра электронных компонентов.

Собственная эффективная логистика и склад в обеспечивает надежную поставку продукции в точно указанные сроки по всей России.

Мы осуществляем техническую поддержку нашим клиентам и предпродажную проверку качества продукции. На все поставляемые продукты мы предоставляем гарантию .

Осуществляем поставки продукции под контролем ВП МО РФ на предприятия военно-промышленного комплекса России , а также работаем в рамках 275 ФЗ с открытием отдельных счетов в уполномоченном банке. Система менеджмента качества компании соответствует требованиям ГОСТ ISO 9001.

Минимальные сроки поставки, гибкие цены, неограниченный ассортимент и индивидуальный подход к клиентам являются основой для выстраивания долгосрочного и эффективного сотрудничества с предприятиями радиоэлектронной промышленности, предприятиями ВПК и научно-исследовательскими институтами России.

С нами вы становитесь еще успешнее!

### Наши контакты:

**Телефон:** +7 812 627 14 35

**Электронная почта:** [sales@st-electron.ru](mailto:sales@st-electron.ru)

**Адрес:** 198099, Санкт-Петербург,  
Промышленная ул, дом № 19, литера Н,  
помещение 100-Н Офис 331