

STACO ENERGY[®] PRODUCTS CO.

Your Tailored Power Solutions Provider™

Variable Transformer Voltage Controls

0.24 to 1500 kVA

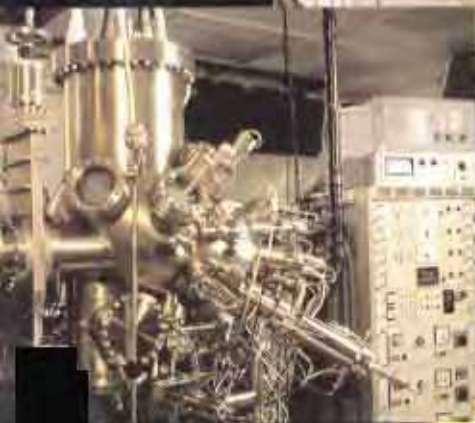

Table of Contents

Introduction and How to Specify and Order	1
Product Design and Engineering Data	2
Schematics and Wiring Diagrams	8
Product Sections by Series	
100/200 Series	10
500 Series	12
1000/1200 Series	14
1500 Series	18
2500 Series	20
5000 Series	22
6000 Series	30
Isolated Series	35
Enclosed Cord and Plug	
3PN Series	36
L Series	37
Variable Transformer Controllers	
FRC-20 Full Range Controller	38
Type MP Microprocessor Controller	39
"Quick Step" Motorized Variable Transformers	40
Paralleling Chokes	40
<i>Product Quick Selector</i>	41



Introduction

STACO Energy Products Co. has been a leading manufacturer of Variable Transformers for over 60 years, building standard as well as custom-designed products for industrial, commercial, and military applications.

STACO's complete line of variable transformers and AC voltage controls are available from a nationwide network of industrial and scientific distributors. Local STACO distributors and representatives have factory trained personnel capable of assisting you in selecting the transformer best suited for your application. Contact our customer service department for the name of the distributor or representative near you.

If our standard products do not meet your specific requirements, contact us at STACO. Our engineering staff is available to solve your special application requirements. Often, it

just requires minor revisions to standard components, enabling STACO to keep your costs to a minimum.

How to Order and Specify

Selecting the STACO Variable Transformer best suited for your specific requirements is easy once you make the following basic determinations:

Input — Line voltage? Single or three phase? Frequency?

Output — Voltage? Amperage? KVA?

To assist you in making the proper selection, an explanation of STACO's standard numbering system is described below. The Product Quick Selector, a tabular listing by rating for each product, starts on page 41.

STACO Numbering System

The basic single units (open construction) are identified by 3 or 4 digits, i.e., 501-B, 1010B, 5021, etc. The first two digits designate current; the third, voltage; the fourth is simply a decimal locator.

1. In a 3 digit number, the first digit indicates amperes; the second indicates the additional fraction of amperes, the third indicates voltage.

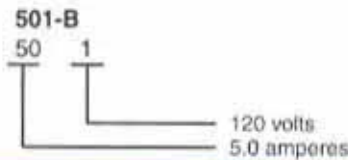

2. In a 4 digit number where the third digit is 1, the first two digits indicate amperes, the third designates 120 volts.

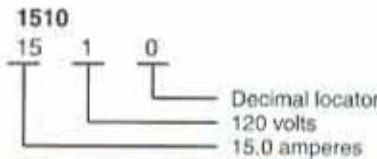

3. In a 4 digit number where the third digit is 2, the first two digits are twice (approximately) the amperes, the third designates 240 volts.

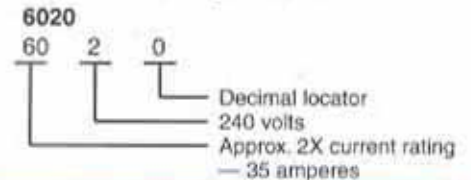

Prefixes & Suffixes

STACO Variable Transformers are available in many different configurations. These other models can be identified by adding the following prefixes or suffixes to the basic 3 or 4 digit numbers.

Prefixes

- 5M } "5," etc. — speed in seconds of travel
- 15M } M — motorized
- 30M }
- 60M }
- 3PN 3 prong cord and receptacle
- J Isolated unit
- L L series (fully enclosed)

Suffixes

- 2 thru -27 Ganged units "-2," 2 gang, etc.
- A Ammeter
- C Cased
- D Delta connected
- E Nema 1 drip-proof enclosure
- G Military
- H 400 Hertz
- K Less knob

Suffixes continued

- N Less dial
- P Parallel connected
- PS Parallel series, connected
- S Series connected
- T Terminal box
- V Voltmeter
- W Wattmeter
- Y Wye connected

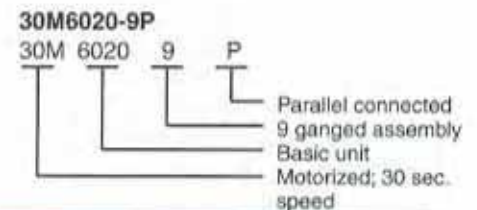
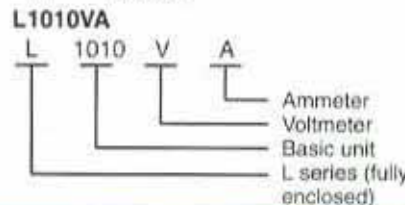
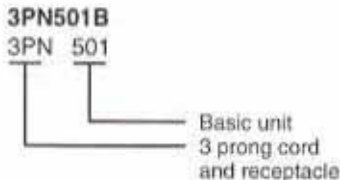

120 Volt Series Unit Ratings

SERIES	MAX. CONSTANT CURRENT	AMPERES* CONSTANT IMPEDANCE
171	1.75	2.2
201	2.0	2.5
221-B	2.5	3.2
291	3.0	3.5
501-B	5.0	7.0
1010B	10.0	13.0
1210B	12.0	15.0
1510	15.0	20.0
2510	25.0	30.0
5011	50.0	—
6011	60.0	—

240 Volt Series Unit Ratings

SERIES	MAX. CONSTANT CURRENT	AMPERES* CONSTANT IMPEDANCE
252	0.8	1.0
1020B	3.5	5.0
1220B	5.0	7.0
1520	9.5	12.0
2520	10.0	13.0
5021	28.0	—
6020	35.0	—

* Nominal ratings. Consult each catalog Series for detailed specifications.

Dimensions

Dimensions are provided throughout this catalog in inches [millimeters].

* Nominal ratings. Consult each catalog Series for detailed specifications.

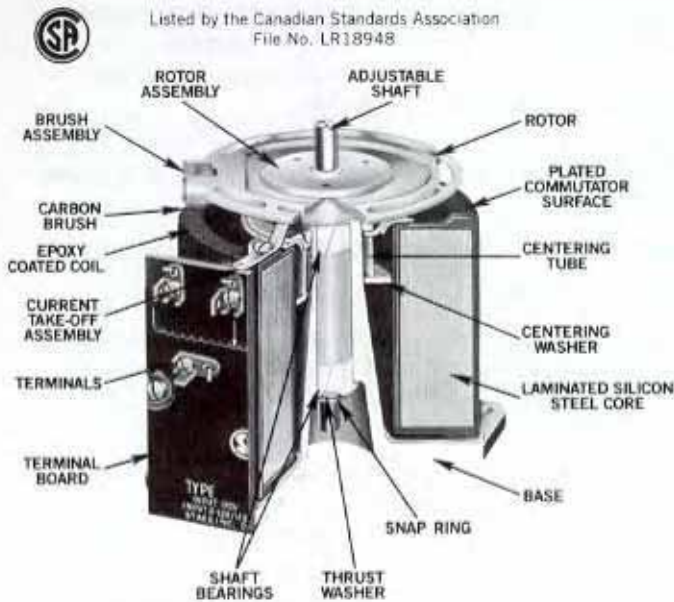

Type 1010B Cutaway

General Information

STACO ENERGY PRODUCTS CO. is a leading manufacturer of variable transformers, the most versatile and reliable voltage controls available. Variable transformers have many industrial and laboratory applications as basic components to control voltage, current, power, heat, speed, light, and electromechanical force.

A basic STACO Variable Transformer consists of a single layer, magnet wire, winding on a toroidal core of laminated silicon steel. A carbon brush, connected to an output lead, is rotated over a precision ground, plated commutator track to tap off voltage at any turn from zero to the maximum output voltage of the winding.

STACO research has developed design features and proprietary processes providing longer lasting, more reliable products. Particularly important is the high-temperature foundation material bonding the coil securely to the core assembly. This material, which has a high thermal transfer characteristic, dissipates heat from the brush contact area, increases the heat-distribution of the core itself and provides the transformer with greater tolerance to transients and short-term overloads.

VOLTAGE RATINGS

Basic single STACO Variable Transformers are rated either 120 volts or 240 volts. Higher voltage requirements are met by combining or ganging 120-volt or 240-volt units. A 480-volt, single-phase application can be met with two 240-volt variable transformers ganged in a series connection. In three-phase applications, three 120-volt units are ganged in a wye connection to result in a 240-volt line-to-line three-phase assembly. Similarly, three 240-volt units are ganged in a wye connection to result in a 380-volt or a 480-volt line-to-line three-phase assembly. In each of these instances, the individual transformers, or coils, are identified with the basic voltage rating, either 120 volts or 240 volts. When variable transformers are connected in open delta for three-phase applica-

tions, two 120-volt units are ganged for 120-volt line-to-line usage. For 240-volt open delta applications, two 240-volt units are ganged with the open delta assembly. In any of the above voltage applications, higher current requirements are met by paralleling two or more units in the ganged assembly.

EFFICIENCY & REGULATION

In contrast to inefficient, wattage-burning resistive-type controllers such as rheostats, STACO Variable Transformers have an extremely low power loss and efficiencies as high as 98%.

STACO Variable Transformers deliver any desired voltage (within the transformer rating) with negligible variation in output voltage from no-load to full-load current. Voltage drop tables and a sample regulation curve are provided in this section.

DISTORTIONLESS VOLTAGE CONTROL

STACO Variable Transformers produce an accurate transfer of input wave to output circuit, providing distortionless voltage control (a requisite of many sophisticated electronic applications).

PLATED COMMUTATOR SURFACE

The commutator surface of each coil is specially plated with precious metal, giving STACO commutators longer life, increased resistance to corrosion and the capacity to withstand greater overloads (while maintaining a constant contact voltage drop).

SIMPLE INSTALLATION AND CONNECTION

Mounting and hook-up of STACO units is convenient and easy. Most series units are designed with an adjustable shaft to accommodate either bench or panel mount (adjustable to accommodate varying panel thickness). Terminals are easily accessible: screw, lug, quick-connect or solder design. Connections deliver increasing output voltage with either clockwise or counter-clockwise knob rotation. Manually operated units have standard dials graduated 0-100 (percentage of output voltage).

LONGER LIFE WITH NEGLIGIBLE MAINTENANCE

Precise design assembly of the brush (at a constant pressure to a smoothly finished and securely bonded commutator surface) provides excellent mechanical performance, long life, and low-driving torque. Brush replacement is seldom needed, but it is easily performed. High safety margins of voltage, current-carrying capacity and dielectric strength are why you can expect longer life from STACO Variable Transformers.

SMOOTH AND LINEAR VOLTAGE CONTROL

STACO Variable Transformers are designed with a fraction of a volt per turn. Close adjustment of output voltage is easy because the brush always contacts one or more turns. Coil turns are evenly spaced, and output voltage is proportional to angular rotation. Full angular travel is approximately 320 degrees on all Series.

VOLTAGE DOUBLER (DUAL INPUT)

Most 240-volt models have an additional input voltage tap permitting normal overvoltage output, with half normal input voltage. The output current must be reduced when the output voltage exceeds 125% of the input voltage as shown in Fig. B on page 6.

TEMPERATURE & RATING

The low loss of STACO Variable Transformers allows operation at full current rating @ ambient temperatures up to 50 degrees C (122 degrees F). In locations above this temperature, the output current must be reduced according to Fig. A on page 6. On single-transient loads and on-off cycled loads, output currents up to 10 times normal may be carried for brief intervals, as shown in Fig. C on page 6.

MILITARY SPECIFICATIONS

All STACO Variable Transformer models are available on special order to meet certain military specifications. Typical of the requirements which can be met are:

ALTITUDE	PHENOLIC PARTS
CONNECTING WIRE	SHOCK
CORROSION	VIBRATION
HUMIDITY	

RUGGED MECHANICAL CONSTRUCTION

STACO Variable Transformers are precision built to exacting mechanical tolerances using the finest materials available. Quality assurance inspections are performed to insure that the high designed-in quality is maintained throughout the manufacturing cycle. A STACO Variable Transformer provides accurate, reliable and lasting voltage control for a broad variety of applications.

General Definitions

The following words or phrases are commonly used to describe characteristics of STACO Variable Transformers.

INPUT VOLTAGE: The supply voltage to which a STACO Variable Transformer is connected.

FREQUENCY: All units in this catalog operate in the range of 50 to 60 HERTZ unless otherwise noted. These units may be used on higher frequencies within the limits shown in the tabulations in the section "Operation at Higher Frequency," page 5.

OUTPUT VOLTAGE: The range of voltage available at the output terminals.

CURRENT RATING TERMINOLOGY: To permit maximum utilization of STACO Variable Transformers, output ratings are given for both constant current and constant impedance loads.

CONSTANT CURRENT RATING: Output current that can be carried regardless of output voltage setting. (Reduce, for output above 125% of input voltage, on voltage doubler connection.)

CONSTANT IMPEDANCE RATING: Output current that can be carried with loads such as incandescent lamps or resistance heaters in which the current drawn is approximately proportional to the applied voltage, increasing to maximum current at line voltage. This rating applies only to applications where maximum output voltage is limited to line voltage.

KVA RATING: The maximum output current at maximum output line voltage multiplied by that maximum voltage and

divided by 1000 for single phase. Divide by 577 for three phase ($1000/\sqrt{3}$).

OVERVOLTAGE CONNECTION: Output voltage from zero to 17% above line voltage (10% for 171 through 291 Series).

LINE VOLTAGE CONNECTION: Output voltage from zero to line voltage.

VOLTAGE DOUBLER CONNECTION: Unit gives full over-voltage output with half normal input voltage. Available on most 240- and 480-volt units. Reduce output current when output voltage exceeds 125% of input voltage.

REGULATION:

$$\frac{VNL - VFL}{VNL} \times 100 \text{ (percent)}$$

VNL = Output Volts No Load
VFL = Output Volts Full Load

DRIVING TORQUE: Torque required to turn the STACO Variable Transformer shaft.

ROTATION: Rotation of STACO Variable Transformer shaft gives increase in output voltage (as viewed from referenced end).

SINGLE UNIT TAP AND TERMINAL DIAGRAM: Input connection is shown for normal overvoltage output. Optional line voltage and voltage doubler input are indicated. Winding section voltages are for a normal overvoltage (or voltage doubler) connection at input voltage shown. Line voltage connections give 85% of these voltages (90% on 171 through 291 Series). Cased units with line cord may omit several coil taps.

CONNECTION — SINGLE PHASE UNIT: Terminals are provided on most models for zero to 117% of input voltage (over-voltage connection) and zero to 100% of input voltage (line voltage connection).

CONNECTION — SINGLE PHASE PARALLEL: Up to nine units on the same shaft may be paralleled by using suitable chokes and circuits to multiply the current and KVA rating. Parallel operation of smaller ganged units is not recommended because it is usually more economical to handle rated loads with the capacity of larger single units. (See specification charts in each transformer series section.)

CONNECTION — SINGLE PHASE SERIES: By jumpering the common connections, two equal single units (or two equal groups of paralleled units) driven by the same shaft may be used at double voltage (line-to-line) in single phase series with external connection only to the input and output terminals. The load must be grounded. If an input neutral is connected to the common, an output neutral may be used. Transformer or loads need not be balanced to neutral.

CONNECTION — THREE PHASE OPEN DELTA: By jumpering the common connections, two equal single units (or two equal groups of paralleled units) driven by the same shaft may be used at normal voltages (line-to-line) in three phase open delta. One power line, identical on input and output, connects to the common. The other input lines connect to the two input terminals, and the two output terminals feed the other output lines. (This connection is the same as single phase series with neutral, except that here voltages on all input line pairs are equal and out of phase.)

Product Design & Engineering Data

CONNECTION — THREE PHASE WYE: By jumpering the common connections, three equal single units (or three equal groups of paralleled units) driven by the same shaft may be used at double voltages (line-to-line) in three phase wye. The load must be ungrounded. Input lines connect to the three input terminals, and the three output terminals feed the output lines. If ganged units are used in a system that ordinarily has a common neutral or ground between source and load, then the neutral or ground must also be connected to the common point of the ganged variable transformer assembly. If the system has no neutral, then the loads must be balanced. Because of the 115.5% voltage on the individual single units, there are 50 HERTZ restrictions. See specifications for each Series.

BENCH MOUNTING: Mounting of STACO Variable Transformers on floor, bench, or wall where the knob and brush rotors of single units (and most multiple units) are at the same end of the coils.



CASED MODELS: All 1010B to 6020 Series models are available in cased designs (identified by the suffix "C," "CT" or "E" in the type number). "C" styles enclose only the coil, while "CT" models provide protective housing for both coil and terminal board. Knockouts are provided in the terminal board housing to accommodate conduit or cable connections. "E" styles include our NEMA 1, drip-proof, fully front accessible enclosures for our 5000/6000 Series.



BACK OF PANEL MOUNTING: Mounting of STACO Variable Transformers with shaft passing through a panel. The knob and brush rotors of single units (and most multiple units) are at opposite ends of the coils.

ISOLATED VARIABLE TRANSFORMERS: An Isolated Variable Transformer consists of two (primary and secondary) magnet wire windings on a toroidal core. The primary winding is electrically isolated from the secondary winding. The input winding has 82% of the turns of the output winding so the output voltage can be varied from 0-122% of the input voltage.

UNCASED (OPEN CONSTRUCTION) MODELS: The basic models of all series are uncased designs. The type number contains no prefix or suffix letter. These models do not have a protective housing for coil or terminal board. Adjustable shaft design on most manually operated models permits back-of-panel or bench mounting.



PORTABLE CORD & PLUG MODELS: Cased plug-in models have a ventilated steel case, line cord, receptacle, illuminated on/off switch and fuse. A three-conductor (3PN prefix) line cord and matching receptacle are available on these units. Plug-in models are connected for output voltage in a clockwise rotation and are available in each Series through the 2510/2520 units.



L SERIES: A selected grouping of variable transformers packaged in a deluxe aluminum enclosure, three-conductor line cord, plug, matching receptacle, pilot light, switch and fuse. An ammeter and voltmeter are available on the 10 amp model.



General Design Specifications

The table below lists general design values for each standard unit on a per coil basis. The DC resistance is as measured from start to finish of coil winding, no load losses are actual core losses, and the torque values are the driving torque required to move the rotor and brush assembly. Using per coil values listed, total DC resistance and core losses can be calculated for parallel or series connected ganged units, and total torque requirements can be determined.

Type	Coil DC Res. (Ohms)	Per Coil Value No Load 60 Hz Losses (Watts)	Driving Torque (oz-in)
171	23.6	1.5	6 max
201	23.8	1.5	6 max
221-B	14.5	1.8	6 max
252	115	2.0	6 max
291	8.0	2.2	6 max
501-B	4.4	3.0	10-30
511	4.4	3.0	10-30
1010B	1.2	5.4	15-35
1020B	11.4	5.2	15-35
1210B	0.6	6.4	15-35
1220B	4.4	6.4	15-35
1510	0.3	13.2	15-35
1520	1.4	18.0	15-35
2510	0.21	14.7	60 max
2520	1.7	14.5	60 max
5011	0.090	28.0	105-160
5021	0.353	28.0	105-160
6011	0.144	7.5	105-160
6020	0.478	7.5	105-160

OPERATION AT HIGHER FREQUENCY

All STACO standard Variable Transformers are designed to operate within a frequency range of 50 to 60 Hertz unless otherwise noted. While designed to operate at 50/60 Hz, Staco Variables can be operated at frequencies up to 2000 Hz. The table below lists unit maximum output current rating at 50/60, 400, 1500, and 2000 HZ.

Type	Maximum Output Current (Amperes)							
	50/60 Hz		400 Hz		1500 Hz		2000 Hz	
	Constant	Constant	Constant	Constant	Constant	Constant	Constant	Constant
	I	Z	I	Z	I	Z	I	Z
171	1.75	2.2	1.75	2.2	1.75	2.2	1.75	2.2
201	2.0	2.5	2.0	2.5	2.0	2.5	2.0	2.5
221-B	2.5	3.2	2.5	3.2	2.5	3.2	2.5	3.2
252	0.8	1.0	0.8	1.0	0.8	1.0	0.8	1.0
291	3.0	3.5	3.0	3.5	3.0	3.5	3.0	3.5
501-B	5.0	7.0	5.0	7.0	5.0	7.0	5.0	7.0
511	5.0	7.0	5.0	7.0	5.0	7.0	5.0	7.0
1010B	10.0	13.0	10.0	13.0	9.0	11.7	9.0	11.7
1020B	3.5	5.0	3.5	5.0	3.5	5.0	3.5	5.0
1210B	12.0*	15.0*	12.0	15.0	3.2	4.5	3.2	4.5
1220B	5.0*	7.0*	5.0	7.0	4.5	6.3	4.5	6.3
1510	15.0	20.0	12.5	17.0	5.0	7.0	5.0	7.0
1520	7.5	10.0	7.5	10.0	3.5	4.3	3.5	4.3
2510	25.0	30.0	18.6	30.0	9.0	11.5	9.0	11.5
2520	10.0	13.0	9.3	13.0	3.3	5.0	3.3	5.0
5011	50.0	—	22.5	22.5	—	—	—	—
5021	28.0	—	14.0	14.0	—	—	—	—
6011	60.0	—	25.0	25.0	—	—	—	—
6020	35.0	—	17.0	17.0	—	—	—	—

* 60 Hz only

EFFICIENCY

Efficiency curves are available from STACO or can be drawn similar to the efficiency curve shown below for any units by starting at zero, passing through the knee point, and reaching 98% efficiency at rated voltage.

Knee Point Data

Model Number	% Efficiency	Volts
171	62	23
201	67	24
221-B	73	23
252	65	50
291	67	24
501-B	77	18
1010B/1210B	80	30
1020B/1220B	80	17
1510	86	10
1520	83	20
2510	90	30
2520	87	40
5011	82	27
5021	75	40
6011	87	30
6020	82	38

Efficiency

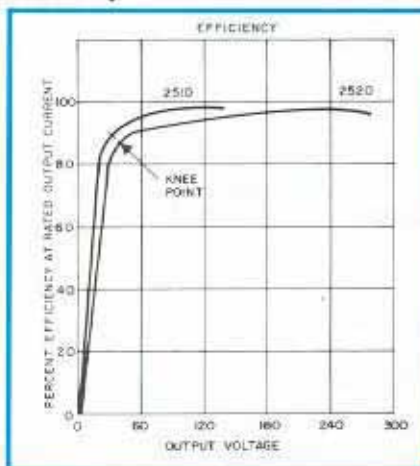

OUTPUT CURRENT LIMITS

Continuous brush output current of STACO Variable Transformers, at normal ambient temperatures, must be limited to the rated amperes. The constant current rating may be drawn at any brush position except in voltage doubler circuits.

For satisfactory life, the brush output current of STACO Variable transformers operated in hot enclosures, or other locations of high ambient temperature, must be limited as shown in Fig. A. Close exposure to radiant heat should be avoided or loading should be reduced accordingly.

For voltage doubler connections (at output voltages above 125 percent of the input voltage) the continuous brush output current must be progressively limited (as shown in Fig. B) down to 44 percent of rated amperes at maximum output voltage. Protection of this type of usage may be approximated with a dual-element lag fuse in the lead to the the input terminal and with either a quick or slow blow fuse in the brush output lead.

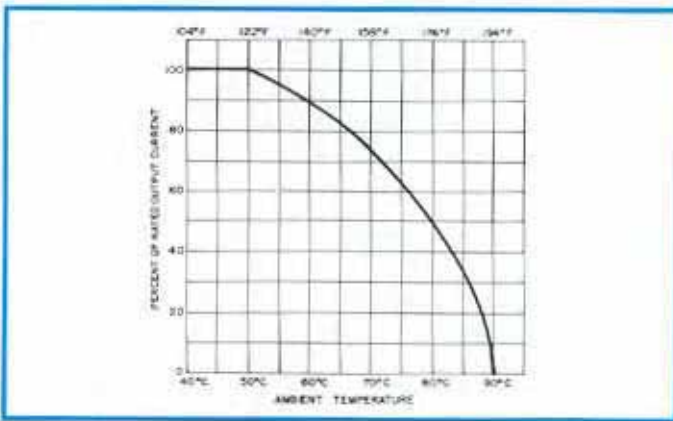

Figure A. Max output current for high temperature

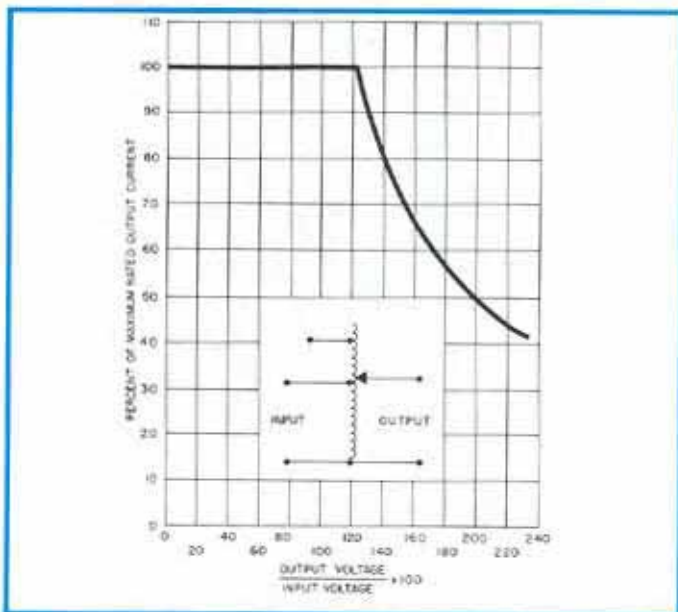

Figure B. Max Output Current — Dual Voltage

SHORT-TIME CURRENT OVERLOAD

Although STACO Variable Transformers are small and light weight for the large power ratings which they handle, brush currents up to 10 times normal may be drawn for a brief time. The maximum on time curve of Fig. C shows the duration of surge on transient currents which may be absorbed by a cold unit on motor starting or similar service. Protection for this level of service may be approximated by hydraulic-magnetic circuit breakers with trip coil in the brush output lead. If the unit is hot from previous loading, such as repetitive overloads, it must also be allowed sufficient off time as indicated on the minimum off time curve of Fig. C to prevent excessive temperatures. If the time on is less than allowed by the "on" curve, the minimum time off may be reduced in accordance with the following equation:

$$\frac{\text{OFF TIME}}{\text{ON TIME}} = \left(\frac{\text{OVERLOAD CURRENT}}{\text{RATED CURRENT}} \right)^2 - 1$$

Protection for this level of service may be approximated by a dual-element lag fuse in the brush output lead.

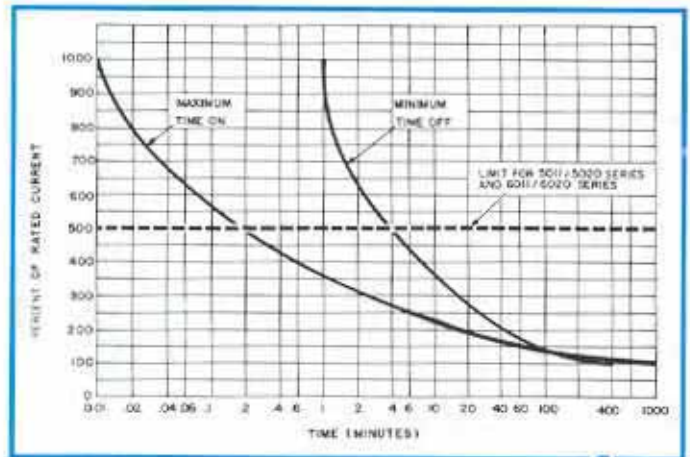

Figure C. Max On Time and Min Off Time for Various Overload Current Conditions

MOTOR-DRIVEN VARIABLE TRANSFORMERS

Motor-driven models permit remote control of large amounts of power. A STACO motor-driven Variable Transformer can be installed in any out-of-the-way space and the control station placed where desired. Extreme flexibility in system design is possible because the control location does not have to accommodate the variable transformer assembly. Motor-driven units have the same electrical ratings as their corresponding manually-operated types.

The motor drive is a compact integral unit mounted on top of the assembly. On cased models, the motor-drive assembly is enclosed and is provided with knock-outs for cable or conduit connections. The permanent magnet synchronous motor operates on 120 volt, 50/60 Hertz single phase lines. Because synchronous motors are frequency sensitive, they operate slightly slower at 50 Hertz.



Standard motor-driven models are available in speeds of 5, 15, 30 and 60 seconds at 60 Hertz for full range travel from zero to maximum output voltage. A smooth, quiet planetary gear unit is used for proper speed reduction from the motor to

the STACO Variable Transformer shaft. Limit switch control at the lower and upper limits of travel prevents overtravel. The limit switches may be adjusted if desired. Additional limit switches may be added for operation and control of auxiliary circuits as required, STACO Auxiliary Switch Kit P/N 964-0057 (available separately).

To specify, prefix the desired time of travel in seconds, and the letter "M" for motor-drive to the Type number. For example: 5 seconds speed travel = 5M1010B.

Normally, one switch is used to operate each Motor-Driven STACO Variable Transformer. Any momentary contact switch, whether lever action or push button, may be used. If desired, additional switches can be provided to permit control from any of several locations. Master control of two or more motor-driven units is also possible using relays or multiple-pole switches.

TYPE FRC-20 AND MP CONTROLLERS

For our Motor Operated Variable Transformers, we offer the FRC-20 and MP Controllers, which both position and regulate the variable transformer. For complete information refer to section on controller types, pages 38 and 39.

Regulation

These tables provide the voltage drop at selected points at the corresponding model's regulation curve. This is the variation in the output voltage from no-load to full-load current. A sample regulation curve for the 6000 Series is illustrated below.

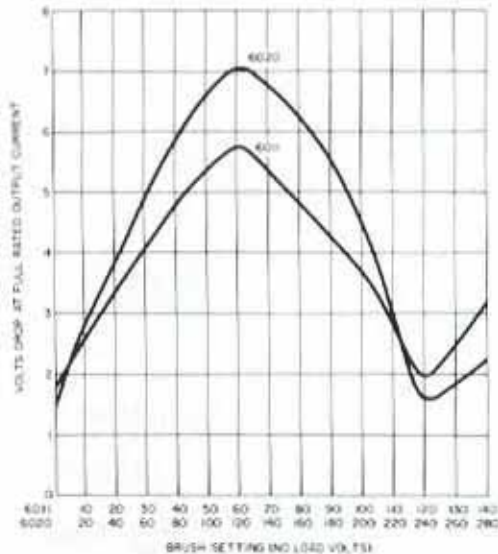

120 Volts - Voltage Drop At Full Rated Output Current

Type	Brush Setting (No Load Volts)						
	0	20	40	60	80	100	120
171	0.2	4.2	7.1	8.5	7.0	4.0	0.2
201	0.2	4.9	7.8	9.0	7.5	4.2	0.3
221-B	0.3	3.0	5.1	6.0	5.0	2.9	0.3
291	0.4	2.5	4.1	5.2	4.2	2.3	0.4
501-B	0.3	3.9	5.2	5.8	5.2	4.0	0.3
511	0.3	3.9	5.2	5.8	5.2	4.0	0.3
1010B	0.2	2.8	4.2	4.5	4.2	3.0	0.8
1210B	0.2	1.3	1.8	2.0	1.8	1.4	0.4
1510	0.1	0.8	1.4	1.7	1.5	0.9	0.2
2510	0.5	1.8	2.2	2.5	2.2	1.9	0.1
5011	3.0	4.2	4.8	5.4	5.2	4.1	3.0
6011	1.9	2.5	3.3	5.7	4.8	3.7	2.0

240 Volts - Voltage Drop At Full Rated Output Current

Type	Brush Setting (No Load Volts)						
	0	40	80	120	160	200	240
252	1.0	13.0	17.5	20.6	17.0	12.5	1.4
1020B	0.2	5.4	6.7	7.0	6.5	5.0	0.4
1220B	0.2	4.5	5.8	6.1	5.6	4.3	0.4
1520	0.2	2.2	3.6	4.0	3.3	2.1	0.3
2520	0.5	4.2	5.2	5.5	5.2	4.2	0.4
5021	2.5	4.2	5.8	7.0	6.6	4.6	2.6
6020	1.4	3.9	5.9	7.0	6.2	4.5	1.6

Schematics and Wiring Diagrams

General Wiring Information

Common is used as the third leg in a three phase open delta or as neutral in a three wire single phase series and four wire, three phase wye connection. It is not used in two wire series or three wire wye connection.

If ganged units are used in a system that ordinarily has a common neutral or ground between source and load, the neutral or ground must be connected to the common terminals of the variable transformer assembly. If the system has no neutral, the load must be balanced or the transformers will be damaged.

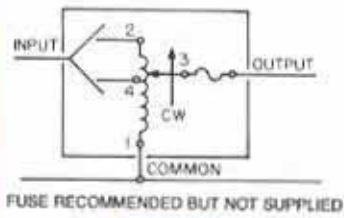

1

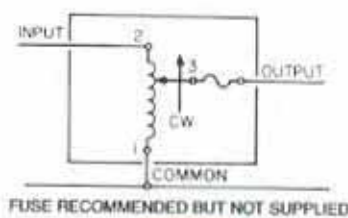

2

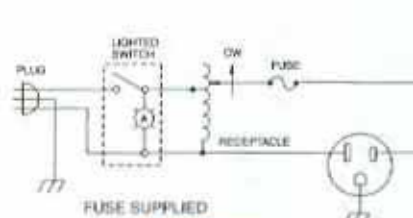

3

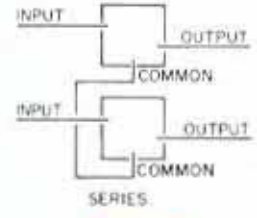

4

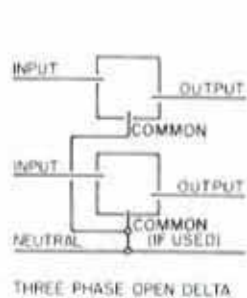

5

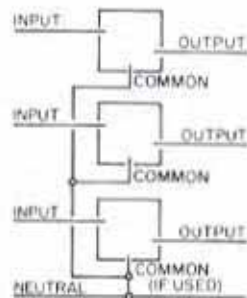

6

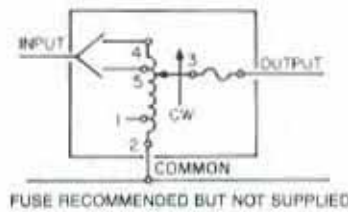

7

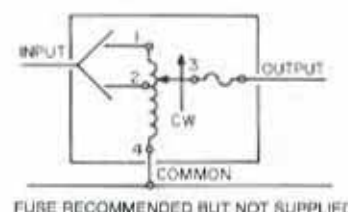

8

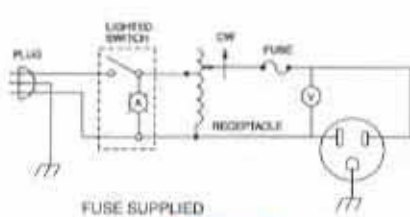

9

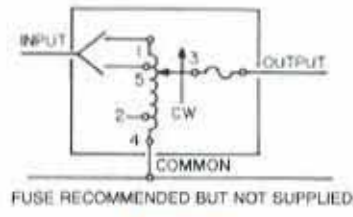

10

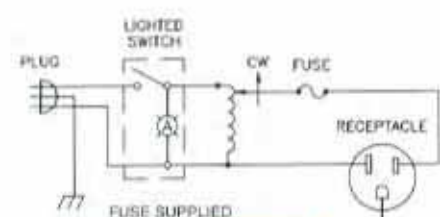

11

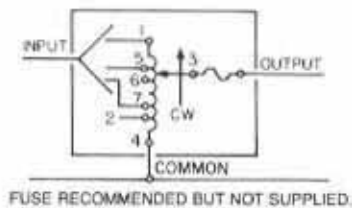

12

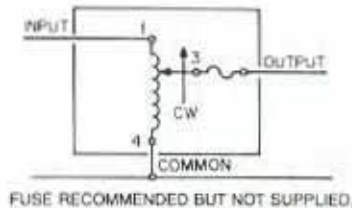

13

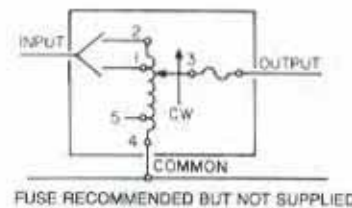

14

Schematics and Wiring Diagrams

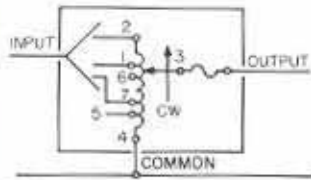

FUSE RECOMMENDED BUT NOT SUPPLIED.

15

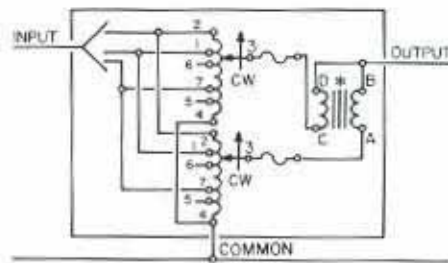

* PARALLELING CHOKE FOR 2510-51LAC
* PARALLELING CHOKE FOR 2520-52LAC
TERMINALS #6 AND #7 OMITTED ON 2510.
FUSE RECOMMENDED BUT NOT SUPPLIED.

16

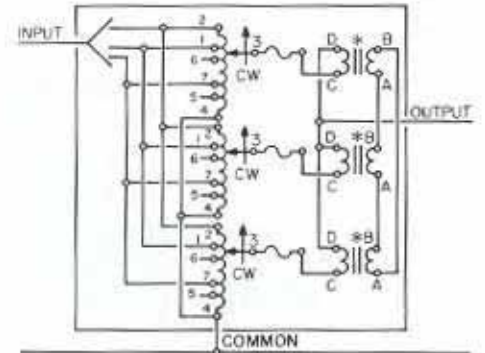

* PARALLELING CHOKE FOR 2510-51LAC
* PARALLELING CHOKE FOR 2520-52LAC
TERMINALS #6 AND #7 OMITTED ON 2510.
FUSE RECOMMENDED BUT NOT SUPPLIED.

17

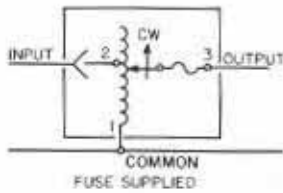

FUSE SUPPLIED.

18

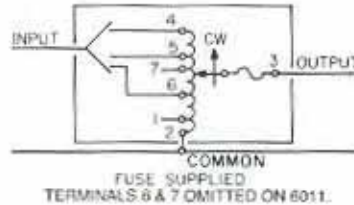

FUSE SUPPLIED.
TERMINALS 6 & 7 OMITTED ON 6011.

19

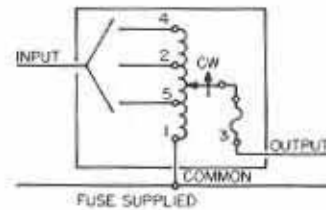

FUSE SUPPLIED.

Terminals 4 and 5 omitted on 5011 Series
Terminal 5 omitted on 6011 Series

20

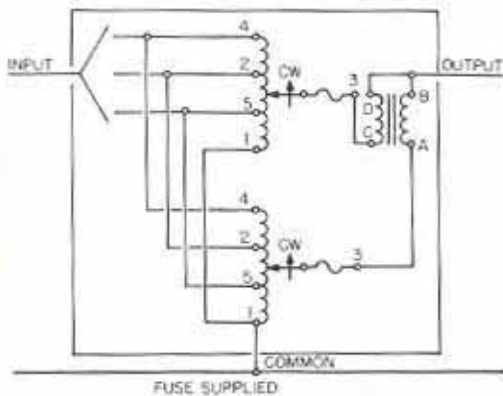

FUSE SUPPLIED.

Terminals 4 and 5 omitted on 5011 Series
Terminal 5 omitted on 6011 Series

21

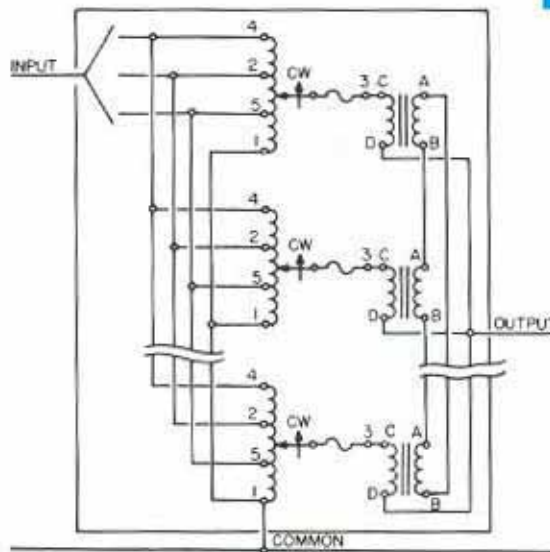

FUSE SUPPLIED.

Terminals 4 and 5 omitted on 5011 Series
Terminal 5 omitted on 6011 Series

22

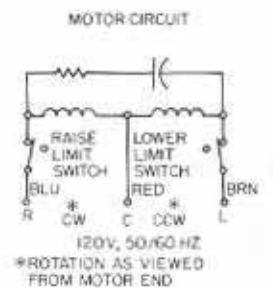

120V, 50/60 HZ
* ROTATION AS VIEWED FROM MOTOR END

23

100/200 Series

These manually operated panel mounted units are available in single and three phase models from 0.8 to 3.0 amperes. The 171, 201, 221-B and 291 units operate from 120 volt input, while the 252 unit operates from a 240 volt input. STACO's coil tapping arrangement permits an output voltage from 0 to line

voltage in either the clockwise or counterclockwise direction and from 0 to 10% above line voltage in the clockwise direction. Two and three ganged, manually operated units are available for increased single phase voltage ratings and for three phase applications.

PART NO.	WIRING	INPUT		OUTPUT				SHAFT ROTATION FOR VOLTAGE INCREASE	TERMINAL CONNECTIONS (For Increasing Voltage) As Viewed from Base End			SCHEMATIC (Pg 8 & 9)	NET WT. LBS.	
		VOLTS	HERTZ	VOLTS	CONSTANT CURRENT LOAD		CONSTANT IMPEDANCE LOAD		Input	Jumper*	Output			
					MAX AMPS	MAX KVA	MAX AMPS							MAX KVA
171	Single Phase	120	50/60	0-120	1.75	0.21	2.2	0.26	CW	1-2	—	1-3	1	2
			60	0-132	1.75	0.23	—	—	CCW	1-2	—	2-3		
									CW	1-4	—	1-3		
171-2	Single Phase Series	240	50/60	0-240	1.75	0.42	2.2	0.53	CW	2-2	1-1	3-3	1 & 4	4 1/4
			60	0-264	1.75	0.46	—	—	CCW	1-1	2-2	3-3		
									CW	4-4	1-1	3-3		
	Three Phase Open Delta π	120++	50/60	0-120	1.75	0.36	2.2	0.46	CW	2-1-2	1-1	3-1-3	1 & 5	4 1/4
			60	0-132	1.75	0.40	—	—	CCW	1-2-1	2-2	3-2-3		
									CW	4-1-4	1-1	3-1-3		
171-3	Three Phase Wye π	240++	60	0-240	1.75	0.73	2.2	0.92	CW	2-2-2	1-1-1	3-3-3	1 & 6	6 1/2
									CCW	1-1-1	2-2-2	3-3-3		
201	Single Phase	120	50/60	0-120	2.0	0.24	2.5	0.30	CW	1-2	—	1-3	1	2
			60	0-132	2.0	0.26	—	—	CCW	1-2	—	2-3		
									CW	1-4	—	1-3		
201-2	Single Phase Series	240	50/60	0-240	2.0	0.48	2.5	0.60	CW	2-2	1-1	3-3	1 & 4	4 1/4
			60	0-264	2.0	0.53	—	—	CCW	1-1	2-2	3-3		
									CW	4-4	1-1	3-3		
	Three Phase Open Delta π	120++	50/60	0-120	2.0	0.42	2.5	0.52	CW	2-1-2	1-1	3-1-3	1 & 5	4 1/4
			60	0-132	2.0	0.46	—	—	CCW	1-2-1	2-2	3-2-3		
									CW	4-1-4	1-1	3-1-3		
201-3	Three Phase Wye π	240++	60	0-240	2.0	0.83	2.5	1.04	CW	2-2-2	1-1-1	3-3-3	1 & 6	6 1/2
									CCW	1-1-1	2-2-2	3-3-3		
221-B	Single Phase	120	50/60	0-120	2.5	0.30	3.2	0.38	CW	1-2	—	1-3	1	2 1/2
			60	0-132	2.5	0.33	—	—	CCW	1-2	—	2-3		
									CW	1-4	—	1-3		
221-B-2	Single Phase Series	240	50/60	0-240	2.5	0.60	3.2	0.77	CW	2-2	1-1	3-3	1 & 4	5 1/2
			60	0-264	2.5	0.66	—	—	CCW	1-1	2-2	3-3		
									CW	4-4	1-1	3-3		
	Three Phase Open Delta π	120++	50/60	0-120	2.5	0.52	3.2	0.67	CW	2-1-2	1-1	3-1-3	1 & 5	5 1/2
			60	0-132	2.5	0.57	—	—	CCW	1-2-1	2-2	3-2-3		
									CW	4-1-4	1-1	3-1-3		
221-B-3	Three Phase Wye π	240++	60	0-240	2.5	1.04	3.2	1.33	CW	2-2-2	1-1-1	3-3-3	1 & 6	8 1/4
									CCW	1-1-1	2-2-2	3-3-3		
3PN221B	Single Phase	120	60	0-132	2.50	0.33	—	—	CW	LINE CORD & RECEPTACLE			3	3
252	Single Phase	240	50/60	0-240	0.8	0.19	1.0	0.24	CW	1-2	—	1-3	1	2 1/2
			60	0-264	0.8	0.21	—	—	CCW	1-2	—	2-3		
									CW	1-4	—	1-3		
252-2	Single Phase Series	480	50/60	0-480	0.8	0.38	1.0	0.48	CW	2-2	1-1	3-3	1 & 4	5 1/2
			60	0-528	0.8	0.42	—	—	CCW	1-1	2-2	3-3		
									CW	4-4	1-1	3-3		
	Three Phase Open Delta π	240++	50/60	0-240	0.8	0.33	1.0	0.42	CW	2-1-2	1-1	3-1-3	1 & 5	5 1/2
			60	0-264	0.8	0.37	—	—	CCW	1-2-1	2-2	3-2-3		
									CW	4-1-4	1-1	3-1-3		
252-3	Three Phase Wye π	480++	50/60	0-480	0.8	0.67	1.0	0.83	CW	2-2-2	1-1-1	3-3-3	1 & 6	8 1/4
			60	0-528	0.8	0.73	—	—	CCW	1-1-1	2-2-2	3-3-3		
									CW	4-4-4	1-1-1	3-3-3		

PART NO.	WIRING	INPUT		OUTPUT				SHAFT ROTATION FOR VOLTAGE INCREASE	TERMINAL CONNECTIONS (For increasing Voltage) As Viewed from Base End			SCHE-MATIC (Pg 8 & 9)	NET WT. LBS.	
		VOLTS	HERTZ	VOLTS	CONSTANT CURRENT LOAD		CONSTANT IMPEDANCE LOAD		Input	Jumper*	Output			
					MAX AMPS	MAX KVA	MAX AMPS							MAX KVA
291	Single Phase	120	50/60	0-120	3.0	0.36	3.5	0.42	CW	1-2	—	1-3	1	2 1/2
			60	0-132	3.0	0.40	—	—	CCW	1-2	—	2-3		
291-2	Single Phase Series	240	50/60	0-240	3.0	0.72	3.5	0.84	CW	2-2	1-1	3-3	1 & 4	5 1/2
			60	0-264	3.0	0.79	—	—	CCW	1-1	2-2	3-3		
	Three Phase Open Delta π	120++	50/60	0-120	3.0	0.62	3.5	0.73	CW	2-1-2	1-1	3-1-3	1 & 5	5 1/2
			60	0-132	3.0	0.69	—	—	CCW	1-2-1	2-2	3-2-3		
291-3	Three Phase Wye π	240++	60	0-240	3.0	1.25	3.5	1.45	CW	2-2-2	1-1-1	3-3-3	1 & 6	8 1/4
									CCW	1-1-1	2-2-2	3-3-3		

* Jumper provided in the standard common position and should be moved or removed as required.

++ Line to line voltage

π If ganged units are used in a system that ordinarily has a common neutral or ground between source and load, the neutral or ground must be connected to the common terminals of the variable transformer assembly. If the system has no neutral, the load must be balanced or the transformers will be damaged.



221-B



201-3

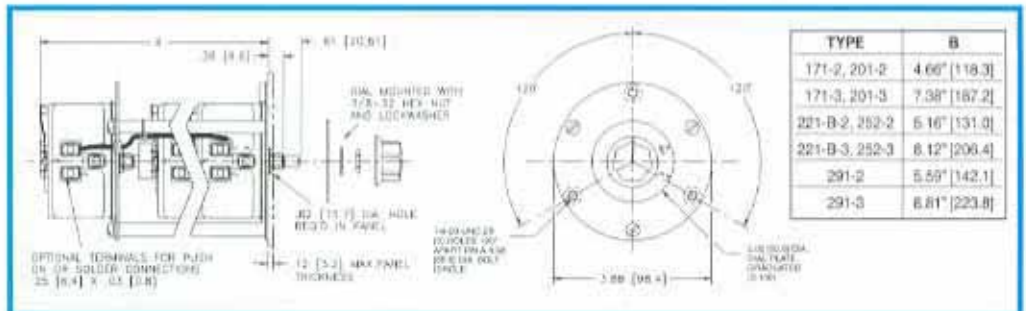
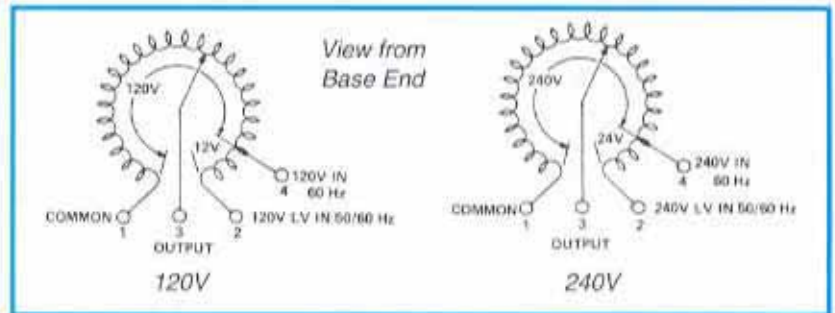

Two and Three Gang Units

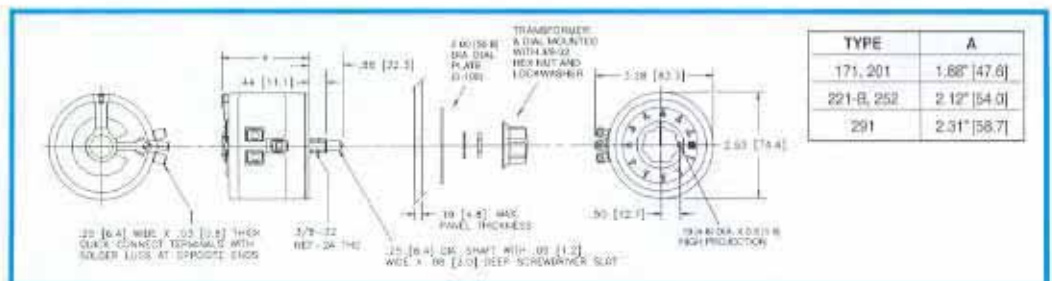

Single Unit

500 Series

Versatility, compactness and durability are included in the many designed-in features of the STACO 501-B Series Variable Transformers. These transformers operate from 120 volt input lines and are rated at 5 amperes for constant current loads and 7 amperes for constant impedance loads at line voltage. The coil tapping arrangement permits output voltage of 0 to line voltage or 17% above line voltage on constant current line conditions. This unit's Faston® terminals are easily converted to screw connections with the terminal adapter kits supplied with each unit.

The STACO 511 is ideal for OEM applications with its panel mount, fixed shaft design and even smaller envelope than the

501-B. It can be single point or four point mounted. The four point mounting is the same as the 501-B.

Either unit can be operated from 50-2000 hertz without derating.

Motor driven units are available and identified by the prefix "M" in the type number. The synchronous motor is designed for operation on 120 volt, 50/60 Hertz single phase lines and draws approximately 0.3 amperes. If a motor driven model is ordered, be sure to prefix the part number with the desired travel time from 0 to maximum of 5, 15, 30, or 60 seconds.

PART NO.	WIRING	INPUT		OUTPUT				SHAFT ROTATION FOR VOLTAGE INCREASE	TERMINAL CONNECTIONS (For Increasing Voltage) As Viewed from Base End			SCHE-MATIC (Pg 8 & 9)	NET WT. LBS.	(Max) MOTOR DRIVEN	
		VOLTS	HERTZ	VOLTS	CONSTANT CURRENT LOAD		CONSTANT IMPEDANCE LOAD		Input	Jumper*	Output				
					MAX AMPS	MAX KVA	MAX AMPS								MAX KVA
501-B M501-B+	Single Phase	120	50/60	0-120	5.0	0.60	7.0	0.84	CW	1-4	—	4-3	10	5 1/4	12
				0-140	5.0	0.70	—	—	CCW	1-4	—	1-3			
									CW	4-5	—	4-3			
									CCW	1-2	—	1-3			
501-B-2 M501-B-2+	Single Phase Series	240	50/60	0-240	5.0	1.2	7.0	1.68	CW	1-1	4-4	3-3	10 & 4	11 1/2	20
				0-280	5.0	1.4	—	—	CCW	4-4	1-1	3-3			
	Three Phase Open Delta	120 ++	50/60	0-120	5.0	1.04	7.0	1.46	CW	1-4-1	4-4	3-4-3	10 & 5		
				0-140	5.0	1-21	—	—	CCW	4-1-4	1-1	3-1-3			
									CW	5-4-5	4-4	3-4-3			
									CCW	2-1-2	1-1	3-1-3			
501-B-3 M501-B-3+	Three Phase Wye	240 ++	50/60	0-240	5.0	2.08	7.0	2.91	CW	1-1-1	4-4-4	3-3-3	10 & 6	15 1/2	26
			60	0-280	5.0	2.43	—	—	CCW	4-4-4	1-1-1	3-3-3			
							CW	5-5-5	4-4-4	3-3-3					
							CCW	2-2-2	1-1-1	3-3-3					
3PN501B	Single Phase	120	50/60	0-140	5.0 ‡	0.70	—	—	CW	LINE CORD & RECEPTACLE			3	7 3/4	
511	Single Phase	120	50/60	0-120	5.0	0.60	7.0	0.84	CW	1-4	—	4-3	8	4 1/2	
				0-140	5.0	0.70	—	—	CCW	4-2	—	4-4			

‡ Unit is fused for the constant current rating at the factory.

* Jumper provided in the standard common position and should be moved or removed as required.

++ Line to line voltage

† If ganged units are used in a system that ordinarily has a common neutral or ground between source and load, the neutral or ground must be connected to the common terminals of the variable transformer assembly. If the system has no neutral, the load must be balanced or the transformers will be damaged.

+ Motor driven units use terminal connections for CCW increasing voltage as viewed from the base end. See figure 23 on page 9 for motor wiring.



501-B



511



501-B-2



5M501-B

500 Series

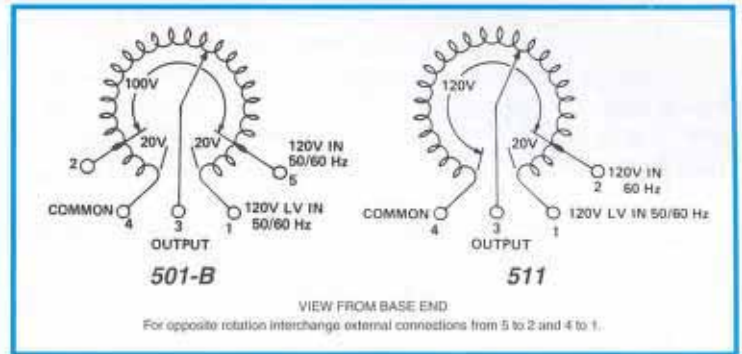
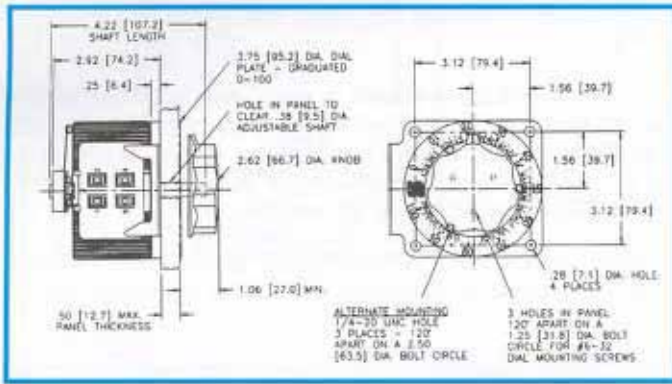

501-B Single Unit

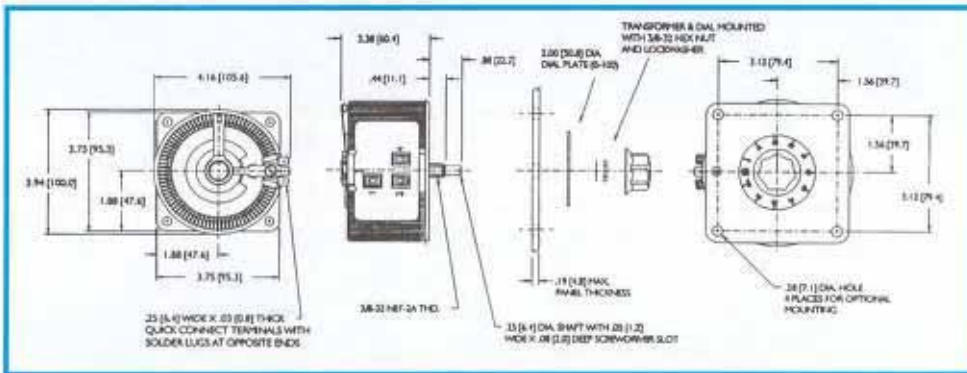

511 Single Unit

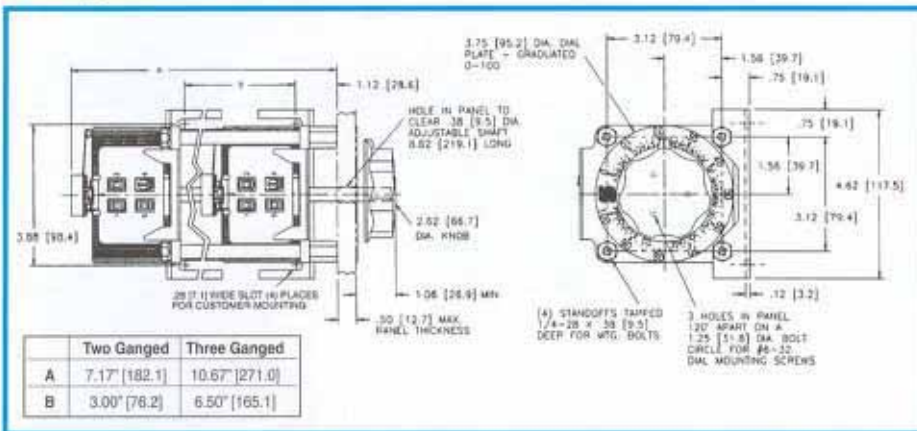

Two and Three Ganged, Manual

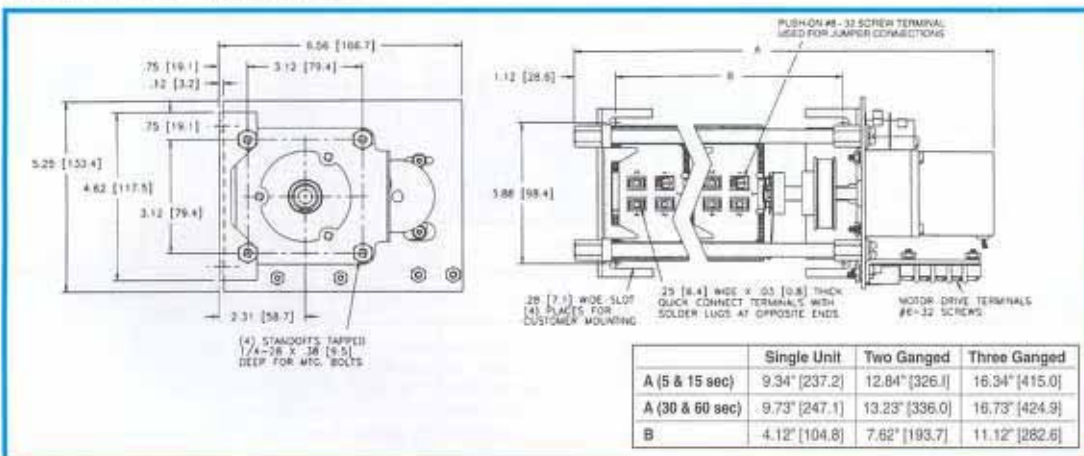

Motorized Single, Two and Three Ganged

1000 Series

STACO's 1010B operates on 120 volts and is rated for constant current of 10 amperes. The 1020B operates on 240 volts and constant current of 3.5 amperes. Coil tapping arrangements allow for 0 to input line voltage or 17% above line voltage. These variable transformers may be operated from 50-1500 hertz with no reduction in output current.

Uncased models have the shaft extending from the base end. This shaft is fully adjustable and can be extended from either end for general utility mounting. Cased styles, which have a "CT" suffix, feature the protective screening over the coil

assembly and a terminal box cover with knock-outs to accept conduit.

Motor driven units are available in single, two and three ganged assemblies; cased or uncased styles as identified by the prefix "M" in the type number. If a motor driven model is ordered, be sure to prefix the part number with the desired travel time from 0 to maximum of 5, 15, 30, or 60 seconds.

The synchronous motor is designed for operation on 120 volts, 50/60 hertz single phase lines and draws approximately 0.3 amperes.

PART NO.	WIRING	INPUT		OUTPUT				SHAFT ROTATION FOR VOLTAGE INCREASE	TERMINAL CONNECTIONS (For increasing Voltage) As Viewed from Base End			SCHEMATIC (Pg 8 & 9)	NET WT. LBS.	(Max) MOTOR DRIVEN	
		VOLTS	HERTZ	VOLTS	CONSTANT CURRENT LOAD		CONSTANT IMPEDANCE LOAD		Input	Jumper*	Output				
					MAX AMPS	MAX KVA	MAX AMPS								MAX KVA
1010B 1010BCT M1010B† M1010BCT†	Single Phase	120	50/60	0-120	10	1.2	13	1.56	CW CCW	1-4 1-4	— —	4-3 1-3	10	10 1/4	16 3/4
				0-140	10	1.4	—	—	—	—	—	—			
1010B-2 1010BCT-2 M1010B-2† M1010BCT-2†	Single Phase Series	240	50/60	0-240	10	2.4	13	3.12	CW CCW	1-1 4-4	4-4 1-1	3-3 3-3	10 & 4	22 1/2	30 7/8
				0-280	10	2.8	—	—	—	—	—	—			
	Three Phase Open Delta	120++	50/60	0-120	10	2.08	13	2.70	CW CCW	1-4-1 4-1-4	4-4 1-1	3-4-3 3-1-3	10 & 5		
				0-140	10	2.42	—	—	—	—	—	—			
1010B-3 1010BCT-3 M1010B-3† M1010BCT-3†	Three Phase Wye	240++	50/60	0-240	10	4.16	13	5.4	CW CCW	1-1-1 4-4-4	4-4-4 1-1-1	3-3-3 3-3-3	10 & 6	34 1/2	42 1/2
			60	0-280	10	4.85	—	—	—	—	—	3-3-3 3-3-3			
3PN1010B	Single Phase	120	50/60	0-140	10‡	1.4	—	—	CW	LINE CORD & RECEPTACLE			3	10 1/4	—
3PN1010BA 3PN1010BV	Single Phase	120	50/60	0-140	10‡	1.4	w/Ammeter w/Voltmeter	—	CW	LINE CORD & RECEPTACLE			9	10 1/4	—
1020B 1020BCT M1020B† M1020BCT†	Single Phase	240	50/60	0-240	3.5	0.84	5.0	1.20	CW CCW	1-4 1-4	— —	4-3 1-3	12	10 1/4	16 3/4
				0-280	3.5	0.98	—	—	—	—	—	—			
		120	50/60	0-280	3.5#	0.42§	—	—	CW CCW	4-7 1-6	— —	4-3 1-3			
1020B-2 1020BCT-2 M1020B-2+ M1020BCT-2+	Single Phase Series	480	50/60	0-480	3.5	1.68	5.0	2.4	CW CCW	1-1 4-4	4-4 1-1	3-2 3-3	12 & 4	22 1/2	30 3/4
				0-560	3.5	1.96	—	—	—	—	—	—			
	Three Phase Open Delta	240++	50/60	0-560	3.5#	0.84§	—	—	CW CCW	7-7 6-6	4-4 1-1	3-3 3-3	12 & 5		
				0-240	3.5	1.45	5.0	2.08	—	—	—	—			
		120++	50/60	0-280	3.5#	0.73§	—	—	CW CCW	7-4-7 6-1-6	4-4 1-1	3-4-3 3-1-3			
1020B-3 1020BCT-3 M1020B-3 M1020BCT-3	Three Phase Wye	480++	50/60	0-480	3.5	2.91	5.0	4.16	CW CCW	1-1-1 4-4-4	4-4-4 1-1-1	3-3-3 3-3-3	12 & 6	34 1/2	42 1/4
			60	0-560	3.5	3.40	—	—	—	—	—	3-3-3 3-3-3			
		240++	60	0-560	3.5#	1.46§	—	—	CW CCW	7-7-7 6-6-6	4-4-4 1-1-1	3-3-3 3-3-3			
3PN1020B	Single Phase	240	50/60	0-280	3.5‡	0.98	—	—	CW	LINE CORD & RECEPTACLE			3	10 1/4	—
3PN1020BA 3PN1020BV	Single Phase	240	50/60	0-280	3.5‡	0.98	w/Ammeter w/Voltmeter	—	CW	LINE CORD & RECEPTACLE			9	10 1/4	—

* Jumper provided in the standard common position and should be moved or removed as required.
 ++ Line to line voltage
 ‡ Unit is fused for the constant current rating at the factory.
 † Motor driven units use terminal connections for CCW increasing voltage, as viewed from the base end. See Fig 23 on page 9 for motor wiring.
 § Maximum KVA at maximum output voltage and corresponding derated output current. Maximum KVA for lower voltages may be calculated from derating curve Figure B, page 6.

π If ganged units are used in a system that ordinarily has a common neutral or ground between source and load, the neutral or ground must be connected to the common terminals of the variable transformer assembly. If the system has no neutral, the load must be balanced or the transformers will be damaged.
 # Maximum output current in output voltage range from 0 to 25% above line voltage. At higher output voltages, the output current must be reduced according to the derating curve. Figure B, page 6.

1000/1200 Series

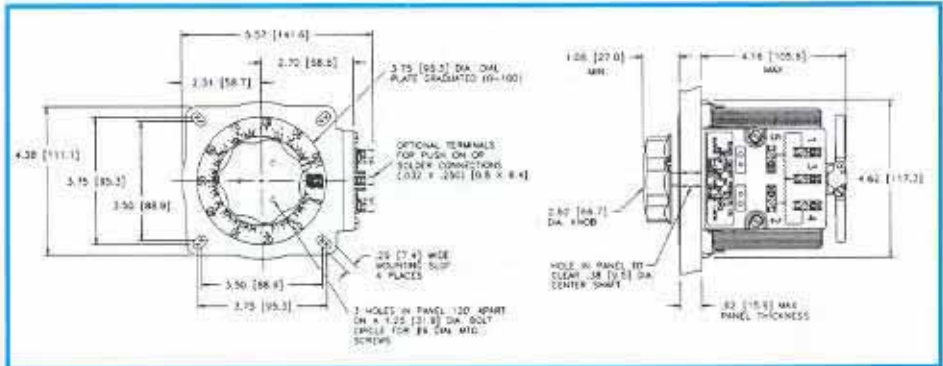
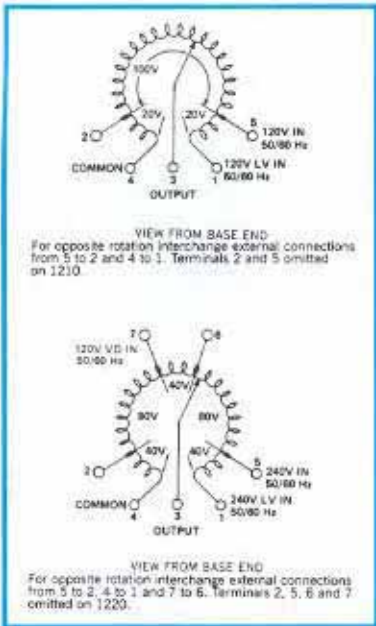

Single Unit, Uncased

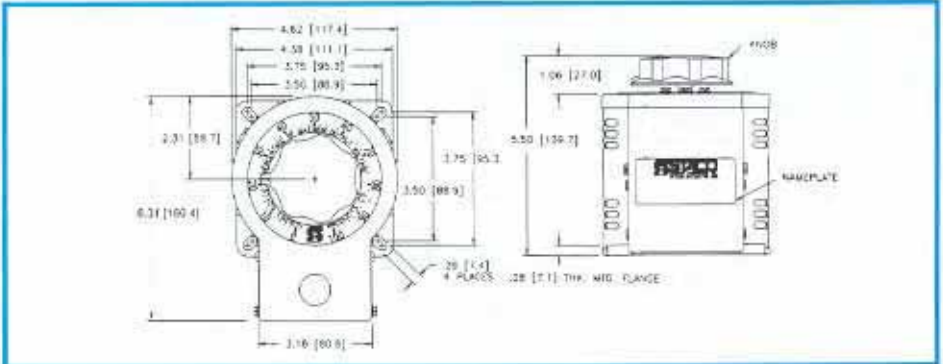

Single Unit, Cased

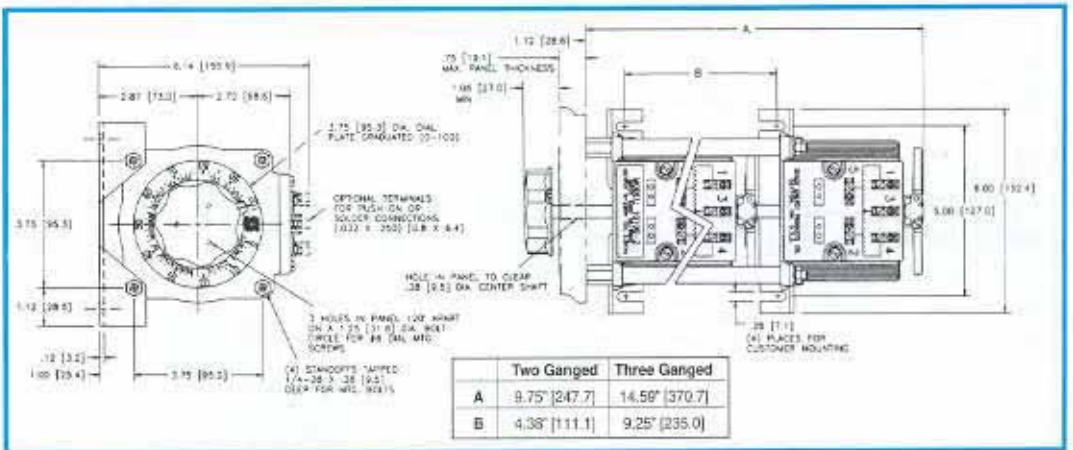

Two and Three Ganged, Uncased

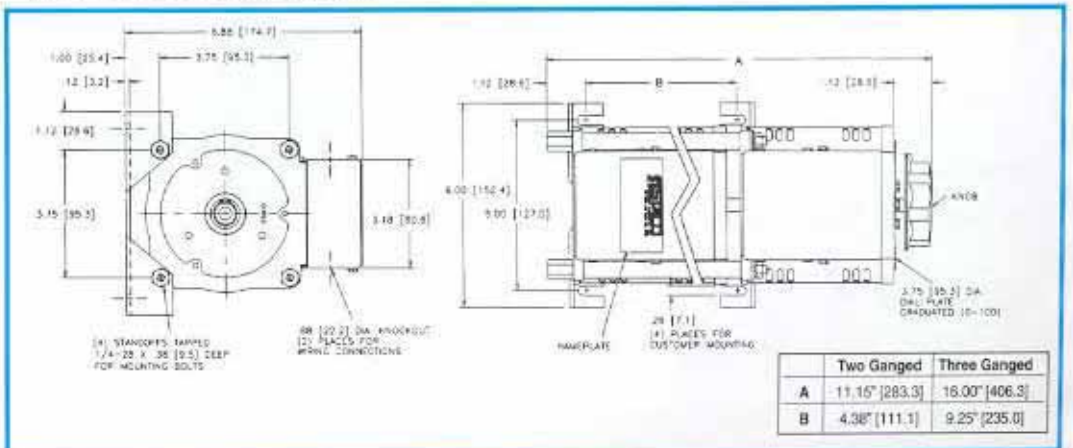

Two and Three Ganged, Cased

1000/1200 Series

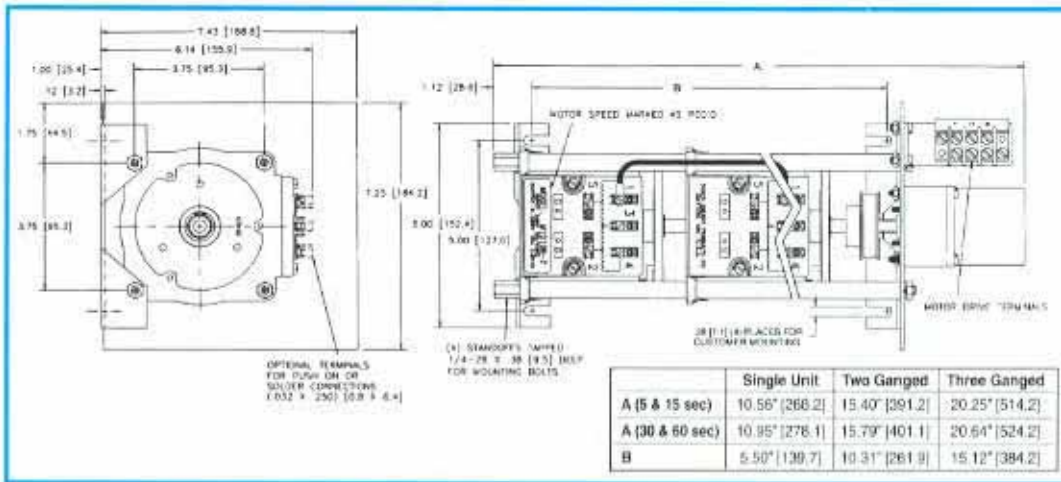

1210B
Front View

Motorized Single, Two and Three Ganged, Uncased

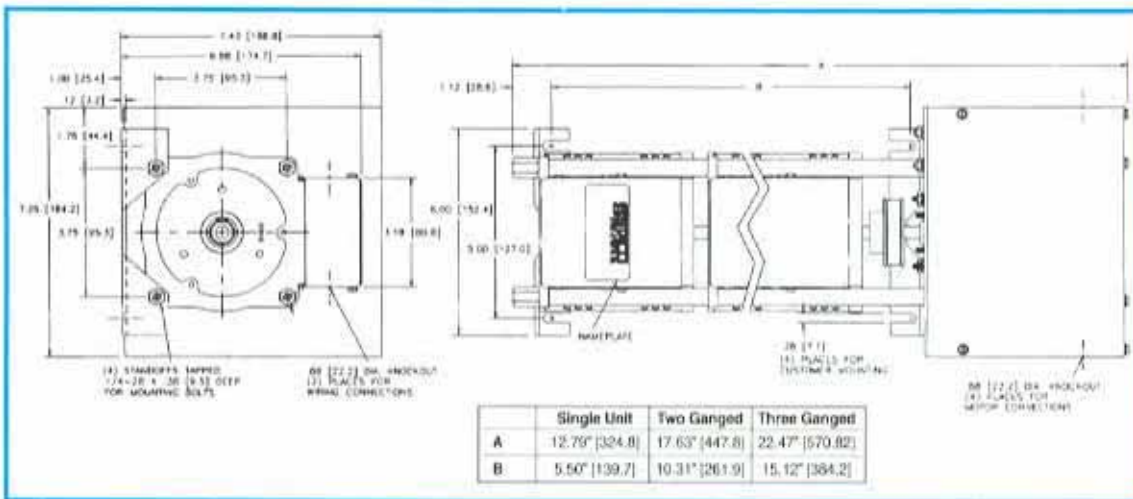

1210B
Rear View

Motorized Single, Two and Three Ganged, Cased



1220BCT-2



15M1010B-2

1200 Series

The 1210B operates on 120 volts and is rated for constant current of 12 amperes. The 1220B operates on 240 volts and constant current of 5 amperes. The 1210B and 1220B operate from 0 to line voltage only. There is no reduction in allowable output current up to 1500 hertz.

Uncased models have the shaft extending from the base end. This shaft is fully adjustable and can be extended from either end for general utility mounting. Cased styles, which have a "CT" suffix, feature the protective screening over the coil assembly and a terminal box cover with knock-outs to

accept conduit.

Motor driven units are available in single, two and three ganged assemblies; cased or uncased styles as identified by the prefix "M" in the type number. If a motor driven model is ordered, be sure to prefix the part number with the desired travel time from 0 to maximum of 5, 15, 30, or 60 seconds.

The synchronous motor is designed for operation on 120 volts, 50/60 hertz single phase lines and draws approximately 0.3 amperes.

PART NO.	WIRING	INPUT		OUTPUT				SHAFT ROTATION FOR VOLTAGE INCREASE	TERMINAL CONNECTIONS (For increasing Voltage) As Viewed from Base End			SCHE-MATIC (Pg 8 & 9)	NET WT. LBS.	(Max) MOTOR DRIVEN	
		VOLTS	HERTZ	VOLTS	CONSTANT CURRENT LOAD		CONSTANT IMPEDANCE LOAD		Input	Jumper*	Output				
					MAX AMPS	MAX KVA	MAX AMPS								MAX KVA
1210B 1210BCT M1210B† M1210BCT†	Single Phase	120	60	0-120	12	1.44	15	1.80	CW CCW	1-4 1-4	— —	4-3 1-3	13	10 1/4	16 3/4
1210B-2 1210BCT-2 M1210B-2† M1210BCT-2†	Single Phase Series	240	60	0-240	12	2.88	15	3.60	CW CCW	1-1 4-4	4-4 1-1	3-3 3-3	13 & 4	22 1/2	30 3/4
	Three Phase Open Delta π	120++	60	0-120	12	2.49	15	3.12	CW CCW	1-4-1 4-1-4	4-4 1-1	3-4-3 3-1-3	13 & 5		
1210B-3 1210BCT-3 M1210B-3† M1210BCT-3†	Three Phase Wye π	240++	60	0-240	12	4.96	15	6.24	CW CCW	1-1-1 4-4-4	4-4-4 1-1-1	3-3-3 3-3-3	13 & 6	34 1/2	42 1/4
3PN1210B	Single Phase	120	60	0-120	12‡	1.44	15	1.80	CW	LINE CORD & RECEPTACLE			11	10 1/4	—
1220B 1220BCT M1220B† M1220BCT†	Single Phase	240	60	0-240	5.0	1.20	7.0	1.68	CW CCW	1-4 1-4	— —	4-3 1-3	13	10 1/4	16 3/4
1220B-2 1220BCT-2 M1220B-2† M1220BCT-2†	Single Phase Series	480	60	0-480	5.0	2.40	7.0	3.36	CW CCW	1-1 4-4	4-4 1-1	3-3 3-3	13 & 4	22 1/2	30 3/4
	Three Phase Open Delta π	240++	60	0-240	5.0	2.08	7.0	2.91	CW CCW	1-4-1 4-1-4	4-4 1-1	3-4-3 3-1-3	13 & 5		
1220B-3 1220BCT-3 M1220B-3† M1220BCT-3†	Three Phase Wye π	480++	60	0-480	5.0	4.16	7.0	5.82	CW CCW	1-1-1 4-4-4	4-4-4 1-1-1	3-3-3 3-3-3	13 & 6	34 1/2	42 1/4
3PN1220B	Single Phase	240	60	0-240	5.0‡	1.20	7.0	1.68	CW	LINE CORD & RECEPTACLE			11	10 1/4	—

* Jumper provided in the standard common position and should be moved or removed as required.

++ Line to line voltage

‡ Unit is fused for the constant current rating at the factory.

† Motor driven units use terminal connections for CCW increasing voltage, as viewed from the base end. See Figure 23 on page 9 for motor wiring.

π If ganged units are used in a system that ordinarily has a common neutral or ground between source and load, the neutral or ground must be connected to the common terminals of the variable transformer assembly. If the system has no neutral, the load must be balanced or the transformers will be damaged.

Maximum output current in output voltage range from 0 to 25% above line voltage. At higher output voltages, the output current must be reduced according to the derating curve, Figure B, page 6.

1500 Series

The 1510/1520 Series Variable Transformers are highly reliable, dependable and accurate AC control devices. The 1510, 120 volt unit is rated at 15 amperes for constant current loads; while the 1520, 240 volt unit is rated at 9.5 amperes for constant current loads. Constant impedance ratings are listed in the specifications. They can be operated at frequencies between 50 and 2000 hertz with derating at higher than rated frequency.

Uncased models have the shaft extending from the base end. This shaft is fully adjustable and can be extended from either end for general utility mounting. Cased styles are available in either "C" style (featuring protective screening over the coil assembly

only) or the "CT" style (which also includes a terminal box cover with knock-outs to accept conduit).

Motor driven units are available in single, two and three ganged assemblies; cased or uncased styles as identified by the prefix "M" in the type number. If a motor driven model is ordered, be sure to prefix the part number with the desired travel time from 0 to maximum of 5, 15, 30, or 60 seconds.

The synchronous motor is designed for operation on 120 volts, 50/60 hertz single phase lines and draws approximately 0.3 amperes.

PART NUMBER		WIRING	INPUT		OUTPUT				SHAFT ROTATION FOR VOLTAGE INCREASE	TERMINAL CONNECTIONS (FOR INCREASING VOLTAGE) AS VIEWED FROM BASE END			SCHEMATIC (Pg 8 & 9)	NET WEIGHT LBS. MAX.										
MANUALLY OPERATED	MOTOR DRIVEN		VOLTS	HERTZ	VOLTS	CONSTANT CURRENT LOAD		CONSTANT IMPEDANCE LOAD		INPUT	JUMPER*	OUTPUT		MAN-UAL	MOTOR DRIVEN									
						MAX AMPS	MAX KVA	MAX AMPS								MAX KVA								
1510 1510C 1510CT	M1510+ M1510C+ M1510CT+	Single Phase	120	50/60	0-120	15	1.80	20	2.40	CW	2-4	—	4-3	14	15 3/4	26								
					0-140	15	2.10	—	—	CCW	2-4	—	2-3				CW	1-4	—	4-3	CCW	5-2	—	2-3
1510-2 1510C-2 1510CT-2	M1510-2+ M1510C-2+ M1510CT-2+	Single Phase Series	240	50/60	0-240	15	3.60	20	4.80	CW	2-2	4-4	3-3	14 & 4	35 1/4	45 1/2								
					0-280	15	4.20	—	—	CCW	4-4	2-2	3-3				CW	1-1	4-4	3-3	CCW	5-5	2-2	3-3
		Three Phase Open Delta	120++	50/60	0-120	15	3.12	20	4.15	CW	2-4-2	4-4	3-4-3	14 & 5										
					0-140	15	3.64	—	—	CCW	4-2-4	2-2	3-2-3				CW	1-4-1	4-4	3-4-3	CCW	5-2-5	2-2	3-2-3
1510-3 1510C-3 1510CT-3	M1510-3+ M1510C-3+ M1510CT-3+	Three Phase Wye	240++	50/60	0-240	15	6.22	20	8.30	CW	2-2-2	4-4-4	3-3-3	14 & 6	55 1/2	65 3/4								
				60	0-280	15	7.26	—	—	CCW	4-4-4	2-2-2	3-3-3				CW	1-1-1	4-4-4	3-3-3	CCW	5-5-5	2-2-2	3-3-3
3PN1510B	—	Single Phase	120	50/60	0-140	15†	2.10	—	—	CW	LINE CORD & RECEPTACLE			3	18	—								
3PN1510BA 3PN1510BV	—	Single Phase	120	50/60	0-140	15†	2.10	—	—	CW	LINE CORD & RECEPTACLE			9	18	—								
1520 1520C 1520CT	M1520+ M1520C+ M1520CT+	Single Phase	240	50/60	0-240	9.5	2.28	12	2.88	CW	2-4	—	4-3	15	19 1/4	29 1/2								
					0-280	9.5	2.66	—	—	CCW	2-4	—	2-3				CW	1-4	—	4-3	CCW	5-2	—	2-3
1520-2 1520C-2 1520CT-2	M1520-2+ M1520C-2+ M1520CT-2+	Single Phase Series	480	50/60	0-480	9.5	4.56	12	5.76	CW	2-2	4-4	3-3	15 & 4	42 1/4	52 1/2								
					0-560	9.5	5.32	—	—	CCW	4-4	2-2	3-3				CW	1-1	4-4	3-3	CCW	5-5	2-2	3-3
					0-560	9.5#	2.28§	—	—	CW	7-7	4-4	3-3				CCW	6-6	2-2	3-3				
		240	50/60	0-240	9.5	3.95	12	5.0	CW	2-4-2	4-4	3-4-3	15 & 5											
				0-280	9.5	4.51	—	—	CCW	4-2-4	2-2	3-2-3		CW			1-4-1	4-4	3-4-3	CCW	5-2-5	2-2	3-2-3	
				0-280	9.5#	1.98§	—	—	CW	7-4-7	4-4	3-4-3		CCW			6-2-6	2-2	3-2-3					
1520-3 1520C-3 1520CT-3	M1520-3+ M1520C-3+ M1520CT-3+	Three Phase Wye	480++	50/60	0-480	9.5	7.90	12	10	CW	2-2-2	4-4-4	3-3-3	15 & 6	66	76 1/4								
				60	0-560	9.5	9.21	—	—	CCW	4-4-4	2-2-2	3-3-3				CW	1-1-1	4-4-4	3-3-3	CCW	5-5-5	2-2-2	3-3-3
		240++	60	0-560	9.5#	3.96§	—	—	CW	7-7-7	4-4-4	3-3-3	15 & 6											
				0-560	9.5#	3.96§	—	—	CCW	6-6-6	2-2-2	3-3-3												
3PN1520B	—	Single Phase	240	50/60	0-280	9.5†	2.66	—	—	CW	LINE CORD & RECEPTACLE			3	22	—								

*A" suffix includes Ammeter, "V" suffix includes Voltmeter

+ Motor driven units use terminal connections for CCW increasing voltage, as viewed from the base end. See Fig 23 on page 9 for motor wiring.

• Jumper provided in the standard common position and should be moved or removed as required.

++ Line to line voltage

† Unit is fused for the constant current rating at the factory.

§ Maximum KVA at maximum output voltage and corresponding derated output current. Maximum KVA for lower voltages may be calculated from derating curve Figure B, page 6.

z If ganged units are used in a system that ordinarily has a common neutral or ground between source and load, the neutral or ground must be connected to the common terminals of the variable transformer assembly. If the system has no neutral, the load must be balanced or the transformers will be damaged.

Maximum output current in output voltage range from 0 to 25% above line voltage. At higher output voltages, the output current must be reduced according to the derating curve, Figure B, page 6.

1500 Series

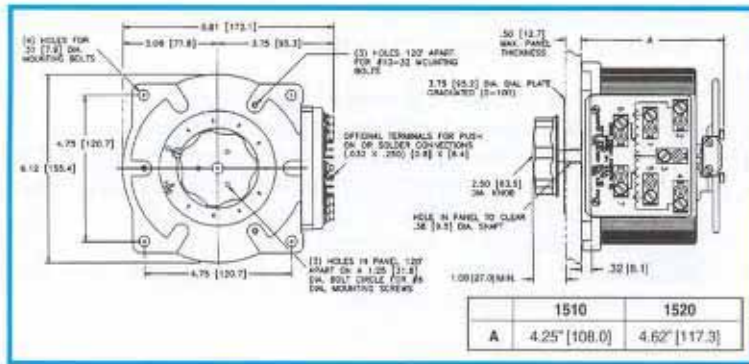

Manual Single, Uncased

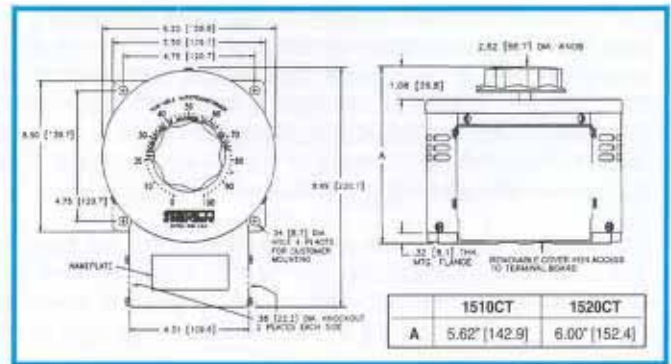

Manual Single, Cased

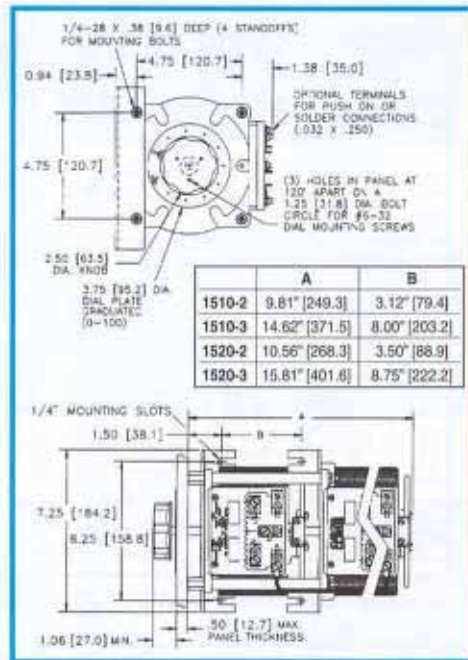
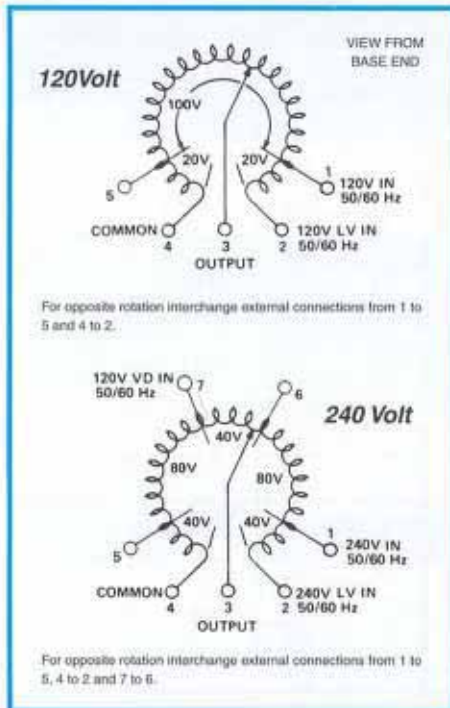

Manual Two- and Three-Ganged, Uncased

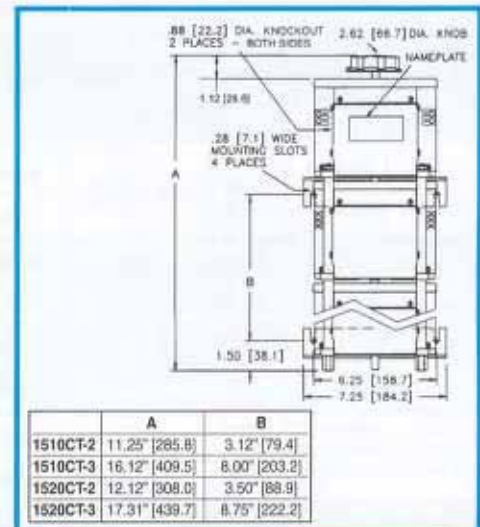

Manual Two- and Three-Ganged, Cased

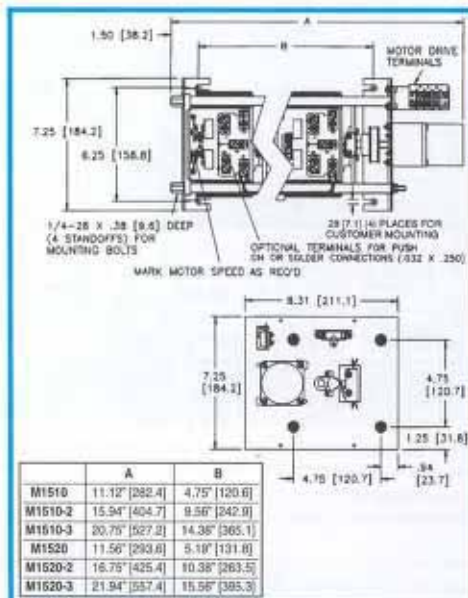

Motor-Driven Single, Two and Three-Ganged, Uncased

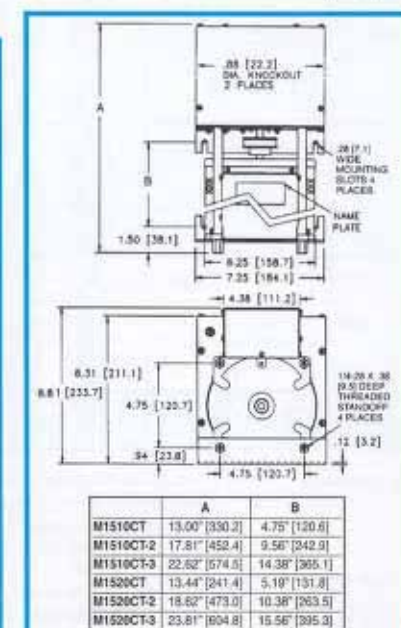

Motor-Driven Single, Two and Three-Ganged, Cased



2500 Series

The 2510/2520 Series Variable Transformers represent a compact high current variable transformer design. The 2510, 120 volt unit is rated at 25 amperes for constant current loads; while the 2520, 240 volt unit is rated at 10 amperes for constant current loads. Constant impedance ratings are listed in the specifications. They can be operated at frequencies between 50 and 2000 Hertz with derating at higher than rated frequency.

Uncased models have the shaft extending from the base end. This shaft is fully adjustable and can be extended from either end for general utility mounting. Cased styles are available in either "C" style (featuring protective screening over the coil

assembly only) or the "CT" style (which also includes a terminal box cover with knock-outs to accept conduit).

Motor-driven models are available in single, two, or three ganged assemblies in cased or uncased styles as identified by the prefix "M" in the part number. If a motor driven model is ordered, be sure to prefix the part number with the desired travel time from 0 to maximum of 5, 15, 30 or 60 seconds. Example: 5M2510CT. The synchronous motor is designed for operation on 120 volts, 50/60 Hertz, single phase lines and draws approximately 0.3 amperes.

PART NUMBER		WIRING	INPUT		OUTPUT				SHAFT ROTATION FOR VOLTAGE INCREASE	TERMINAL CONNECTIONS (FOR INCREASING VOLTAGE) AS VIEWED FROM BASE END			SCHEMATIC (Pg 8 & 9)	NET WEIGHT LBS. MAX.					
MANUALLY OPERATED	MOTOR DRIVEN		VOLTS	HERTZ	VOLTS	CONSTANT CURRENT LOAD		CONSTANT IMPEDANCE LOAD		INPUT	JUMPER*	OUTPUT		MANUAL	MOTOR DRIVEN				
						MAX AMPS	MAX KVA	MAX AMPS								MAX KVA			
2510 2510C 2510CT	M2510+ M2510+ M2510CT+	Single Phase	120	50/60	0-120	25	3.00	30	3.6	CW	2-4	—	4-3	14	21	31			
					0-140	25	3.50	—	—	CCW	2-4	—	2-3						
2510-2 2510C-2 2510CT-2	M2510-2+ M2510C-2+ M2510CT-2+	Single Phase Series	240	50/60	0-240	25	6.00	30	7.2	CW	2-2	4-4	3-3	14 & 4	50	60			
					0-280	25	7.00	—	—	CCW	4-4	2-2	3-3						
					0-120	25	5.20	30	6.2	CW	1-1	4-4	3-3						
		Three Phase Open Delta	120++	50/60	0-120	25	5.20	30	6.2	CW	2-4-2	4-4	3-4-3	14 & 5	50	60			
					0-140	25	6.06	—	—	CCW	4-2-4	2-2	3-2-3						
					0-140	25	6.06	—	—	CW	1-4-1	4-4	3-4-3						
2510-3 2510C-3 2510CT-3	M2510-3+ M2510C-3+ M2510CT-3+	Three Phase Wye	240++	50/60	0-240	25	10.40	30	12.5	CW	2-2-2	4-4-4	3-3-3	14 & 6	68	78			
				60	0-280	25	12.10	—	—	CCW	4-4-4	2-2-2	3-3-3						
3PN2210B		Single Phase	120	50/60	0-140	22†	3.08	—	—	CW	LINE CORD & RECEPTACLE			3	24 1/4	—			
2520 2520C 2520CT	M2520+ M2520C+ M2520CT+	Single Phase	240	50/60	0-240	10	2.40	13	3.12	CW	2-4	—	4-3	15	21	31			
					0-280	10	2.80	—	—	CCW	2-4	—	2-3						
			120	50/60	0-280	10#	1.20§	—	—	CW	1-4	—	4-3	15	21	31			
					0-280	10#	1.20§	—	—	CCW	2-5	—	2-3						
2520-2 2520C-2 2520CT-2	M2520-2+ M2520C-2+ M2520CT-2+	Single Phase Series	480	50/60	0-480	10	4.80	13	6.24	CW	2-2	4-4	3-3	15 & 4	50	60			
					0-560	10	5.60	—	—	CCW	4-4	2-2	3-3						
			240	50/60	0-560	10#	2.40§	—	—	CW	1-1	4-4	3-3	15 & 4	50	60			
					0-560	10#	2.40§	—	—	CCW	5-5	2-2	3-3						
		Three Phase Open Delta	240++	50/60	0-240	10	4.20	13	5.40	CW	7-7	4-4	3-3	15 & 5	50	60			
					0-280	10	4.85	—	—	CCW	2-4-2	4-4	3-4-3						
			120++	50/60	0-280	10#	2.10§	—	—	CW	1-4-1	4-4	3-4-3	15 & 5	50	60			
					0-280	10#	2.10§	—	—	CCW	5-2-5	2-2	3-2-3						
2520-3 2520C-3 2520CT-3	M2520-3+ M2520C-3+ M2520CT-3+	Three Phase Wye	480++	50/60	0-480	10	8.30	13	10.81	CW	2-2-2	4-4-4	3-3-3	15 & 6	68	78			
				60	0-560	10	9.70	—	—	CCW	4-4-4	2-2-2	3-3-3						
			240++	60	0-560	10#	4.20§	—	—	CW	1-1-1	4-4-4	3-3-3	15 & 6	68	78			
					0-560	10#	4.20§	—	—	CCW	5-5-5	2-2-2	3-3-3						
			3PN2520B		Single Phase	240	50/60	0-280	10†	2.80	—	—	CW	7-7-7	4-4-4	3-3-3	3	24 1/4	—
								0-280	10†	2.80	—	—	CCW	6-6-6	2-2-2	3-3-3			

* Jumper provided in the standard common position and should be moved or removed as required.

++ Line to line voltage

† Unit is fused for the constant current rating at the factory.

+ Motor driven units use terminal connections for CCW increasing voltage, as viewed from the base end. See Figure 23 on page 9 for motor wiring.

If ganged units are used in a system that ordinarily has a common neutral or ground between source and load, the neutral or ground must be connected to the common ter-

minals of the variable transformer assembly. If the system has no neutral, the load must be balanced or the transformers will be damaged.

Maximum output current in output voltage range from 0 to 25% above line voltage. At higher output voltages, the output current must be reduced according to the derating curve, Figure B, page 6.

§ Maximum KVA at maximum output voltage and corresponding derated output current. Maximum KVA for lower voltages may be calculated from derating curve Figure B, page 6.

2500 Series

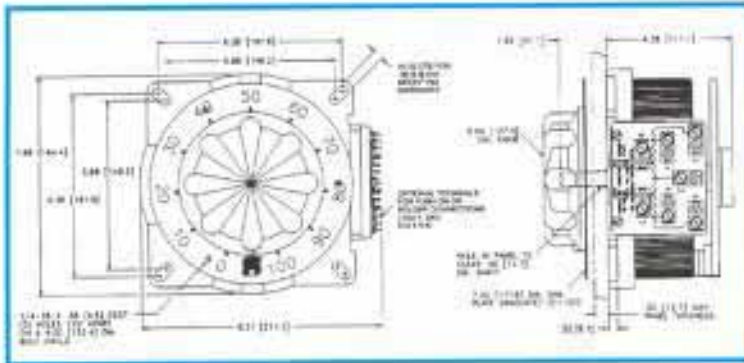

Manual Single, Uncased

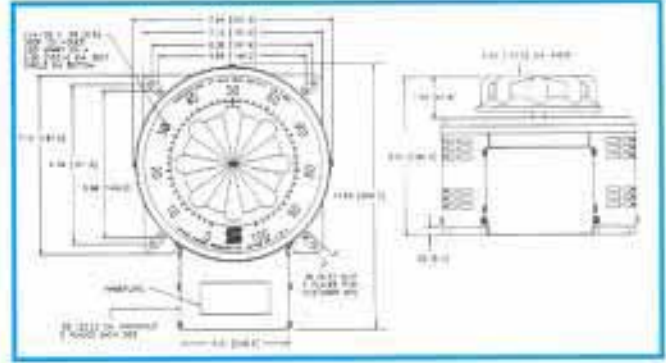

Manual Single, Cased

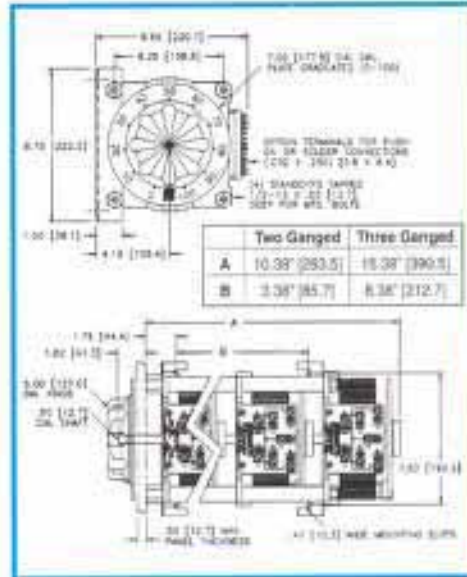
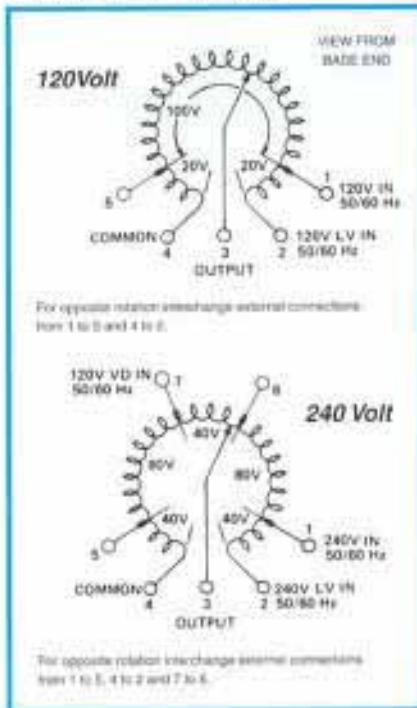

Manual Two and Three-Ganged, Uncased

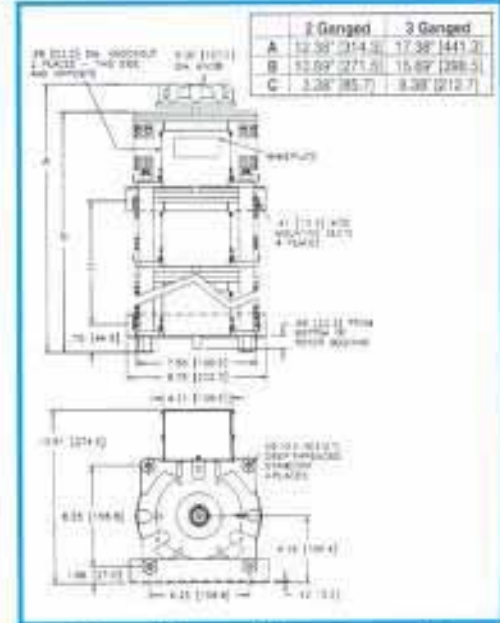

Manual Two and Three-Ganged, Cased

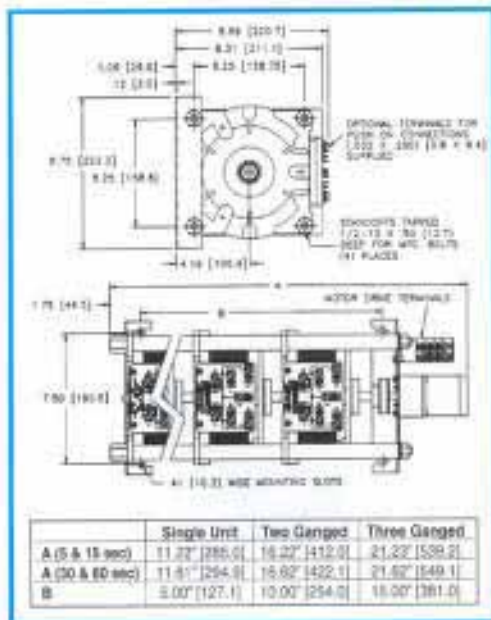

	Single Unit	Two Ganged	Three Ganged
A (5 & 15 sec)	11.32" (288.0)	16.02" (407.3)	21.22" (539.2)
A (30 & 60 sec)	11.81" (299.4)	16.82" (427.1)	21.82" (554.1)
B	5.00" (127.1)	10.00" (254.0)	15.00" (381.0)

Motor-Driven Single, Two and Three-Ganged, Uncased

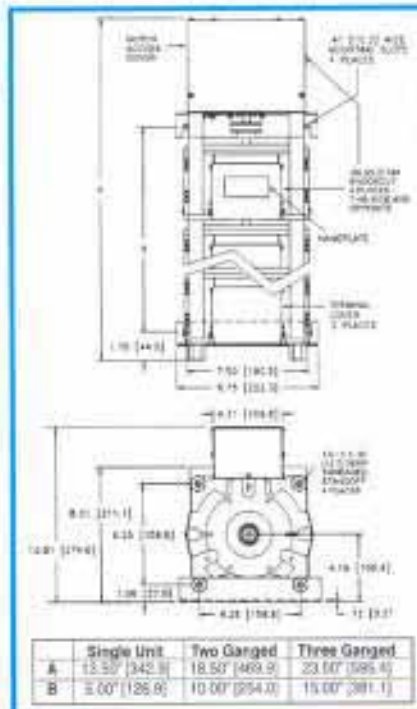

	Single Unit	Two Ganged	Three Ganged
A	13.50" (342.9)	18.50" (469.9)	23.00" (584.2)
B	5.00" (127.0)	10.00" (254.0)	15.00" (381.0)

Motor-Driven Single, Two and Three-Ganged, Cased



5000 Series

The 5011/5021 Series Variable transformers are designed to control large KVA requirements. The 5011 operates on 120 volts and is rated for constant current of 50 amperes. The 5021 operates on 240 volts and constant current of 28 amperes. The 5011 Series units have coil tapping arrangements allowing output voltage from 0-117% of line voltage, while the 5021 Series allows output voltage from 0 to line voltage or 17% above line voltage. They can be operated at frequencies between 50 and 400 Hertz with a rating at higher than rated frequency.

Adjustable shaft design on manually operated models permits back-of-panel or bench mounting. Terminals are 1/4" screw type. For single and two ganged units, case styles are available in either "C" style, which encloses only the coil, or the "CT" style,

which provides protective housing for both the coil and terminal board. Knockouts are provided in the terminal board housing to accommodate conduit or cable connections. For three ganged and above, we offer our Nema 1, dripproof, fully front accessible "E" enclosure.

Motor-driven models are available from single thru 27 ganged assemblies; cased or uncased (identified with the prefix "M" in the part number). The synchronous motor is designed for operation on 120 volt, 50/60 Hertz, single phase lines and draws approximately 0.3 amperes. To meet a wide range of application requirements, standard motor speeds of 5, 15, 30 and 60 seconds are available depending upon the size of the variable transformer.

PART NUMBER		WIRING	INPUT		OUTPUT			SHAFT ROTATION FOR VOLTAGE INCREASE	TERMINAL CONNECTIONS For Increasing Voltage As Viewed from Rotor End		SCHEMATIC (Pg 8 & 9)	NET WEIGHT IN LBS. (MAX)	
MANUALLY OPERATED	MOTOR DRIVEN		VOLTS	HERTZ	VOLTS	MAX AMPS	MAX KVA		INPUT	OUTPUT		MANUAL	MOTOR DRIVEN
5011 5011C 5011CT	M5011 M5011C M5011CT	Single Phase	120	50/60	0-140	50	7.0	CW	1-2	1-3	18	57	78
5021 5021C 5021CT	M5021 M5021C M5021CT	Single Phase	240	50/60	0-240	28	6.7	CW	2-4	2-3	19	57	78
					0-280	28	7.8	CCW	4-2	4-3			
5011-2D 5011C-2D 5011CT-2D	M5011-2D M5011C-2D M5011CT-2D	Three Phase Open Delta	120	50/60	0-140	50	12.1	CW	2-1-2	3-1-3	20 & 5	134	155
5011-2P 5011C-2P 5011CT-2P	M5011-2P M5011C-2P M5011CT-2P	Single Phase Parallel	120	50/60	0-140	100	14.0	CW	1-2	1-B	21	136	157
5011-2S 5011C-2S 5011CT-2S	M5011-2S M5011C-2S M5011CT-2S	Single Phase Series	240	50/60	0-280	50	14.0	CW	2-2	3-3	20 & 4	134	155
5021-2D 5021C-2D 5021CT-2D	M5021-2D M5021C-2D M5021CT-2D	Three Phase Open Delta	240	50/60	0-240	28	11.6	CW	4-1-4	3-1-3	20 & 5	134	155
					0-280	28	13.6	CW	2-1-2	3-1-3			
5021-2P 5021C-2P 5021CT-2P	M5021-2P M5021C-2P M5021CT-2P	Single Phase Parallel	240	50/60	0-240	56	13.4	CW	1-4	1-B	21	136	157
					0-280	56	15.7	CW	1-2	1-B			
5021-2S 5021C-2S 5021CT-2S	M5021-2S M5021C-2S M5021CT-2S	Single Phase Series	480	50/60	0-480	28	13.5	CW	4-4	3-3	20 & 4	134	155
					0-560	28	15.7	CW	2-2	3-3			
5011-3P 5011E-3P	M5011-3P M5011E-3P	Single Phase Parallel	120	50/60	0-140	150	21.0	CW	1-2	1-D	22	216	237
5011-3Y 5011E-3Y	M5011-3Y M5011E-3Y	Three Phase Wye	240	60	0-280	50	24.2	CW	2-2-2	3-3-3	20 & 6	212	233



5011



5021



5021CT-2



5011C

5000 Series

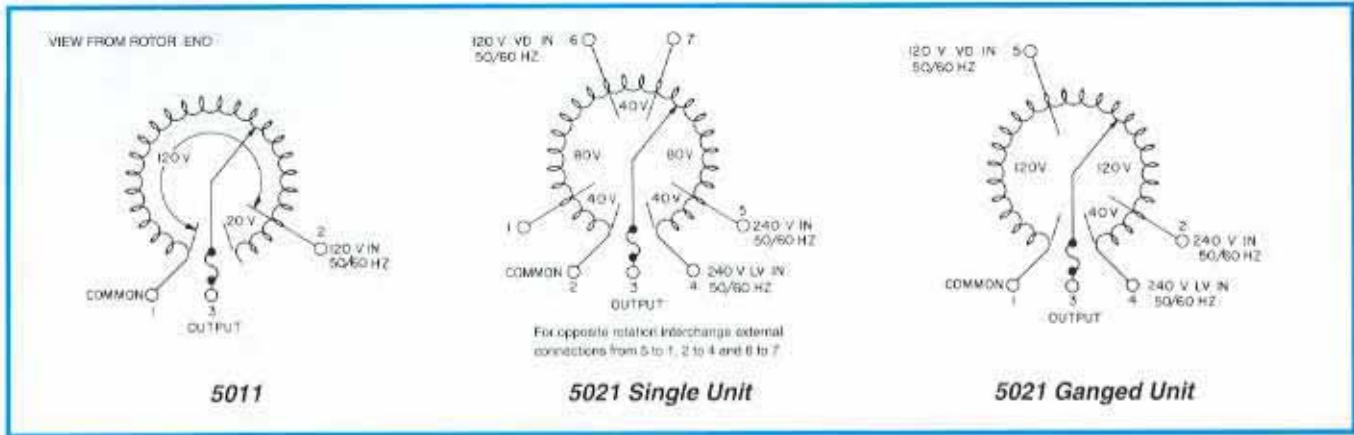

PART NUMBER		WIRING	INPUT		OUTPUT			SHAFT ROTATION FOR VOLTAGE INCREASE	TERMINAL CONNECTIONS For Increasing Voltage As Viewed from Rotor End		SCHEMATIC (Pg 8 & 9)	NET WEIGHT IN LBS. (MAX)	
MANUALLY OPERATED	MOTOR DRIVEN		VOLTS	HERTZ	VOLTS	MAX AMPS	MAX KVA		INPUT	OUTPUT		MANUAL	MOTOR DRIVEN
5021-3P 5021E-3P	M5021-3P M5021E-3P	Single Phase Parallel	240	50/60	0-240	84	20.2	CW	1-4	1-D	22	216	237
			120	50/60	0-280	84	23.5	CW	1-2	1-D			
5021-3Y 5021E-3Y	M5021-3Y M5021E-3Y	Three Phase Wye	480	50/60	0-480	28	23.3	CW	4-4-4	3-3-3	20 & 6	212	233
			240	60	0-560	28	27.2	CW	2-2-2	3-3-3			
5011-4D 5011E-4D	M5011-4D M5011E-4D	Three Phase Open Delta	120	50/60	0-140	100	24.2	CW	2-1-2	B-1-B	21 & 5	314	335
5011-4P 5011E-4P	M5011-4P M5011E-4P	Single Phase Parallel	120	50/60	0-140	200	28.0	CW	1-2	1-D	22	316	337
5011-4PS 5011E-4PS	M5011-4PS M5011E-4PS	Single Phase Series Parallel	240	50/60	0-280	100	28.0	CW	2-2	B-B	21 & 4	314	335
5021-4D 5021E-4D	M5021-4D M5021E-4D	Three Phase Open Delta	240	50/60	0-240	56	23.3	CW	4-1-4	B-1-B	21 & 5	314	335
			120	50/60	0-280	56	27.2	CW	2-1-2	B-1-B			
5021-4P 5021E-4P	M5021-4P M5021E-4P	Single Phase Parallel	240	50/60	0-240	112	26.9	CW	1-4	1-D	22	316	337
			120	50/60	0-280	112	31.4	CW	1-2	1-D			
5021-4PS 5021E-4PS	M5021-4PS M5021E-4PS	Single Phase Series	480	50/60	0-480	56	26.9	CW	4-4	B-B	21 & 4	314	335
			240	50/60	0-560	56	31.4	CW	2-2	B-B			
5011-5P 5011E-5P	M5011-5P M5011E-5P	Single Phase Parallel	120	50/60	0-140	250	35.0	CW	1-2	1-D	22	400	420
5011-6D 5011E-6D	M5011-6D M5011E-6D	Three Phase Open Delta	120	50/60	0-140	150	36.4	CW	2-1-2	D-1-D	22 & 5	481	502
5011-6P 5011E-6P	M5011-6P M5011E-6P	Single Phase Parallel	120	50/60	0-140	300	42.0	CW	1-2	1-D	22	483	504
5011-6PS 5011E-6PS	M5011-6PS M5011E-6PS	Single Phase Series Parallel	240	50/60	0-280	150	42.0	CW	2-2	D-D	22 & 4	481	502
5011-6Y 5011E-6Y	M5011-6Y M5011E-6Y	Three Phase Wye	240	60	0-280	100	48.5	CW	2-2-2	B-B-B	21 & 6	479	500

5000 Series

PART NUMBER		WIRING	INPUT		OUTPUT			SHAFT ROTATION FOR VOLTAGE INCREASE	TERMINAL CONNECTIONS For Increasing Voltage As Viewed from Rotor End		SCHEMATIC (Pg 8 & 9)	NET WEIGHT IN LBS. (MAX)	
MANUALLY OPERATED	MOTOR DRIVEN		VOLTS	HERTZ	VOLTS	MAX AMPS	MAX KVA		INPUT	OUTPUT		MANUAL	MOTOR DRIVEN
5021-6D 5021E-6D	M5021-6D M5021E-6D	Three Phase Open Delta	240	50/60	0-240	84	34.9	CW	4-1-4	D-1-D	22 & 5	481	502
					0-280	84	40.7	CW	2-1-2	D-1-D			
			120	50/60	0-280	84* ³⁶ V.D.	17.6†	CW	5-1-5	D-1-D			
5021-6P 5021E-6P	M5021-6P M5021E-6P	Single Phase Parallel	240	50/60	0-240	168	40.3	CW	1-4	1-D	22	483	504
					0-280	168	47.0	CW	1-2	1-D			
			120	50/60	0-280	168* ⁷² V.D.	20.4†	CW	1-5	1-D			
5021-6PS 5021E-6PS	M5021-6PS M5021E-6PS	Single Phase Series Parallel	480	50/60	0-480	84	40.3	CW	4-4	D-D	22 & 4	481	502
					0-560	84	47.0	CW	2-2	D-D			
			240	50/60	0-560	84* ³⁶ V.D.	20.4†	CW	5-5	D-D			
5021-6Y 5021E-6Y	M5021-6Y M5021E-6Y	Three Phase Wye	480	50/60	0-480	58	46.6	CW	4-4-4	B-B-B	21 & 6	479	500
				60	0-560	56	54.3	CW	2-2-2	B-B-B			
			240	60	0-560	56* ²⁴ V.D.	23.5†	CW	5-5-5	B-B-B			
5011-7P 5011E-7P	M5011-7P M5011E-7P	Single Phase Parallel	120	50/60	0-140	350	49.0	CW	1-2	1-D	22	563	584
5021-7P 5021E-7P	M5021-7P M5021E-7P	Single Phase Parallel	240	50/60	0-240	196	47.0	CW	1-4	1-D	22	563	584
					0-280	196	54.9	CW	1-2	1-D			
			120	50/60	0-280	196* ⁸⁴ V.D.	23.5†	CW	1-5	1-D			
5011-8D 5011E-8D	M5011-8D M5011E-8D	Three Phase Open Delta	120	50/60	0-140	200	48.4	CW	2-1-2	D-1-D	22 & 5	640	661
5011-8P 5011E-8P	M5011-8P M5011E-8P	Single Phase Parallel	120	50/60	0-140	400	56.0	CW	1-2	1-D	22	642	663
5011-8PS 5011E-8PS	M5011-8PS M5011E-8PS	Single Phase Series Parallel	240	50/60	0-280	200	56.0	CW	2-2	D-D	22 & 4	640	661
5021-8D 5021E-8D	M5021-8D M5021E-8D	Three Phase Open Delta	240	50/60	0-240	112	46.6	CW	4-1-4	D-1-D	22 & 5	640	661
					0-280	112	54.3	CW	2-1-2	D-1-D			
			120	50/60	0-280	112* ⁴⁸ V.D.	23.3†	CW	5-1-5	D-1-D			
5021-8P 5021E-8P	M5021-8P M5021E-8P	Single Phase Parallel	240	50/60	0-240	224	53.8	CW	1-4	1-D	22	642	663
					0-280	224	62.7	CW	1-2	1-D			
			120	50/60	0-280	224* ⁹⁶ V.D.	26.9†	CW	1-5	1-D			
5021-8PS 5021E-8PS	M5021-8PS M5021E-8PS	Single Phase Series Parallel	480	50/60	0-480	112	53.8	CW	4-4	D-D	22 & 4	640	742
					0-560	112	62.7	CW	2-2	D-D			
			240	50/60	0-560	112* ⁴⁸ V.D.	26.9†	CW	5-5	D-D			
5011-9P 5011E-9P	M5011-9P M5011E-9P	Single Phase Parallel	120	50/60	0-140	450	63.0	CW	1-2	1-D	22	721	742
5011-9Y 5011E-9Y	M5011-9Y M5011E-9Y	Three Phase Wye	240	60	0-280	150	72.5	CW	2-2-2	D-D-D	22 & 6	717	738
5021-9P 5021E-9P	M5021-9P M5021E-9P	Single Phase Parallel	240	50/60	0-240	252	60.5	CW	1-4	1-D	22	721	742
					0-280	252	70.6	CW	1-2	1-D			
			120	50/60	0-280	252* ¹⁰⁸ V.D.	30.2†	CW	1-5	1-D			
5021-9Y 5021E-9Y	M5021-9Y M5021E-9Y	Three Phase Wye	480	50/60	0-480	84	69.8	CW	4-4-4	D-D-D	22 & 6	717	738
				60	0-560	84	81.5	CW	2-2-2	D-D-D			
			240	60	0-560	84* ³⁶ V.D.	35.0†	CW	5-5-5	D-D-D			
—	M5011-10D M5011E-10D	Three Phase Open Delta	120	50/60	0-140	250	60.6	CW	2-1-2	D-1-D	22 & 5		812
—	M5011-10PS M5011E-10PS	Single Phase Series Parallel	240	50/60	0-280	250	70.0	CW	2-2	D-D	22 & 4		812
—	M5021-10D M5021E-10D	Three Phase Open Delta	240	50/60	0-240	140	58.2	CW	4-1-4	D-1-D	22 & 5		812
					0-280	140	67.9	CW	2-1-2	D-1-D			
			120	50/60	0-280	140* ⁶⁰ V.D.	29.1†	CW	5-1-5	D-1-D			

5000 Series

PART NUMBER		WIRING	INPUT		OUTPUT			SHAFT ROTATION FOR VOLTAGE INCREASE	TERMINAL CONNECTIONS For Increasing Voltage As Viewed from Rotor End		SCHE-MATIC (Pg 8 & 9)	NET WEIGHT IN LBS. (MAX)	
MANUALLY OPERATED	MOTOR DRIVEN		VOLTS	HERTZ	VOLTS	MAX AMPS	MAX KVA		INPUT	OUTPUT		MAN-UAL	MOTOR DRIVEN
—	M5021-10PS M5021E-10PS	Single Phase Series Parallel	480	50/60	0-480	140	67.2	CW	4-4	D-D	22 & 4	—	812
			240	50/60	0-560	140	78.4	CW	2-2	D-D			
—	M5011-12D M5011E-12D	Three Phase Open Delta	120	50/60	0-140	300	72.7	CW	2-1-2	D-1-D	22 & 5	—	940
—	M5011-12PS M5011E-12PS	Single Phase Series Parallel	240	50/60	0-280	300	84.0	CW	2-2	D-D	22 & 4	—	940
—	M5021-12D M5021E-12D	Three Phase Open Delta	240	50/60	0-240	168	69.8	CW	4-1-4	D-1-D	22 & 5	—	940
			120	50/60	0-280	168	81.5	CW	2-1-2	D-1-D			
—	M5021-12PS M5021E-12PS	Single Phase Series Parallel	480	50/60	0-480	168	80.6	CW	4-4	D-D	22 & 4	—	940
			240	50/60	0-560	168	94.1	CW	2-2	D-D			
—	M5011-14D M5011E-14D	Three Phase Open Delta	120	50/60	0-140	350	84.9	CW	2-1-2	D-1-D	22 & 5	—	1097
—	M5011-14PS M5011E-14PS	Single Phase Series Parallel	240	50/60	0-280	350	98.0	CW	2-2	D-D	22 & 4	—	1097
—	M5021-14D M5021E-14D	Three Phase Open Delta	240	50/60	0-240	196	81.5	CW	4-1-4	D-1-D	22 & 5	—	1097
			120	50/60	0-280	196	95.1	CW	2-1-2	D-1-D			
—	M5021-14PS M5021E-14PS	Single Phase Series Parallel	480	50/60	0-480	196	94.1	CW	4-4	D-D	22 & 4	—	1097
			240	50/60	0-560	196	109.8	CW	2-2	D-D			
—	M5011-16D M5011E-16D	Three Phase Open Delta	120	50/60	0-140	400	96.7	CW	2-1-2	D-1-D	22 & 5	—	1254
—	M5011-16PS M5011E-16PS	Single Phase Series Parallel	240	50/60	0-280	400	112.0	CW	2-2	D-D	22 & 4	—	1254
—	M5021-16D M5021E-16D	Three Phase Open Delta	240	50/60	0-240	224	93.1	CW	4-1-4	D-1-D	22 & 5	—	1254
			120	50/60	0-280	224	108.6	CW	2-1-2	D-1-D			
—	M5021-16PS M5021E-16PS	Single Phase Series Parallel	480	50/60	0-480	224	107.5	CW	4-4	D-D	22 & 4	—	1254
			240	50/60	0-560	224	125.5	CW	2-2	D-D			
—	M5011-18D M5011E-18D	Three Phase Open Delta	120	50/60	0-140	450	109.0	CW	2-1-2	D-1-D	22 & 5	—	1417
—	M5011-18PS M5011E-18PS	Single Phase Series Parallel	240	50/60	0-280	450	126.0	CW	2-2	D-D	22 & 4	—	1417
—	M5021-18D M5021E-18D	Three Phase Open Delta	240	50/60	0-240	252	104.5	CW	4-1-4	D-1-D	22 & 5	—	1417
			120	50/60	0-280	252	122.2	CW	2-1-2	D-1-D			
—	M5021-18PS M5021E-18PS	Single Phase Series Parallel	480	50/60	0-480	252	121.0	CW	4-4	D-D	22 & 4	—	1417
			240	50/60	0-560	252	141.0	CW	2-2	D-D			
—	M5011-12Y M5011E-12Y	Three Phase Wye	240	60	0-280	300	96.7	CW	2-2-2	D-D-D	22 & 6	—	942
—	M5021-12Y M5021E-12Y	Three Phase Wye	480	50/60	0-480	112	93.1	CW	4-4-4	D-D-D	22 & 6	—	942
			240	60	0-560	112	108.6	CW	2-2-2	D-D-D			
—			240	60	0-560	112	108.6	CW	5-5-5	D-D-D			

5000 Series

PART NUMBER		WIRING	INPUT		OUTPUT			SHAFT ROTATION FOR VOLTAGE INCREASE	TERMINAL CONNECTIONS For Increasing Voltage As Viewed from Rotor End		SCHE-MATIC (Pg 8 & 9)	NET WEIGHT IN LBS. (MAX)	
MANUALLY OPERATED	MOTOR DRIVEN		VOLTS	HERTZ	VOLTS	MAX AMPS	MAX KVA		INPUT	OUTPUT		MAN-UAL	MOTOR DRIVEN
—	M5011-15Y M5011E-15Y	Three Phase Wye	240	60	0-280	250	121.0	CW	2-2-2	D-D-D	22 & 6	—	1179
—	M5021-15Y M5021E-15Y	Three Phase Wye	480	50/60	0-480	140	116.5	CW	4-4-4	D-D-D	22 & 6	—	1179
			240	60	0-560	140	136.0	CW	2-2-2	D-D-D			
—	M5021E-15Y	Three Phase Wye	240	60	0-560	140*60	58.2†	CW	5-5-5	D-D-D	22 & 6	—	1179
						V.D.							
—	M5011-18Y M5011E-18Y	Three Phase Wye	240	60	0-280	300	145.5	CW	2-2-2	D-D-D	22 & 6	—	1415
—	M5021-18Y M5021E-18Y	Three Phase Wye	480	50/60	0-480	168	139.5	CW	4-4-4	D-D-D	22 & 6	—	1415
			240	60	0-560	168	163.3	CW	2-2-2	D-D-D			
—	M5021E-18Y	Three Phase Wye	240	60	0-560	168*72	70.0†	CW	5-5-5	D-D-D	22 & 6	—	1415
						V.D.							
—	M5011-21Y M5011E-21Y	Three Phase Wye	240	60	0-280	350	169.5	CW	2-2-2	D-D-D	22 & 6	—	1654
—	M5021-21Y M5021E-21Y	Three Phase Wye	480	50/60	0-480	196	163.0	CW	4-4-4	D-D-D	22 & 6	—	1654
			240	60	0-560	196	189.5	CW	2-2-2	D-D-D			
—	M5021E-21Y	Three Phase Wye	240	60	0-560	196*84	82.0†	CW	5-5-5	D-D-D	22 & 6	—	1654
						V.D.							
—	M5011-24Y M5011E-24Y	Three Phase Wye	240	60	0-280	400	193.7	CW	2-2-2	D-D-D	22 & 5	—	1892
—	M5021-24Y M5021E-24Y	Three Phase Wye	480	50/60	0-480	224	186.5	CW	4-4-4	D-D-D	22 & 6	—	1892
			240	60	0-560	224	217.8	CW	2-2-2	D-D-D			
—	M5021E-24Y	Three Phase Wye	240	60	0-560	224*96	93.0†	CW	5-5-5	D-D-D	22 & 6	—	1892
						V.D.							
—	M5011-27Y M5011E-27Y	Three Phase Wye	240	60	0-280	450	218.4	CW	2-2-2	D-D-D	22 & 6	—	2131
—	M5021-27Y M5021E-27Y	Three Phase Wye	480	50/60	0-480	252	209.5	CW	4-4-4	D-D-D	22 & 6	—	2131
			240	60	0-560	252	244.0	CW	2-2-2	D-D-D			
—	M5021E-27Y	Three Phase Wye	240	60	0-560	252*108	105.0†	CW	5-5-5	D-D-D	22 & 6	—	2131
						V.D.							

* Maximum output current in output voltage range from 0 to 25 percent above line voltage. At higher output voltages, output current must be reduced according to rating curve, Figure B, page 6.

† Maximum KVA at maximum output and corresponding de-rated current. Maximum KVA at lower output voltages may be calculated from derating curve. Figure B, page 6.

V. D. Voltage Doubler



5000/6000 Series
Enclosed Unit

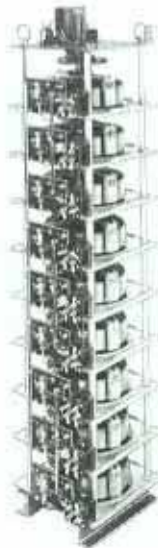

30M6020-9Y



30M5011-3Y

5000/6000 Series

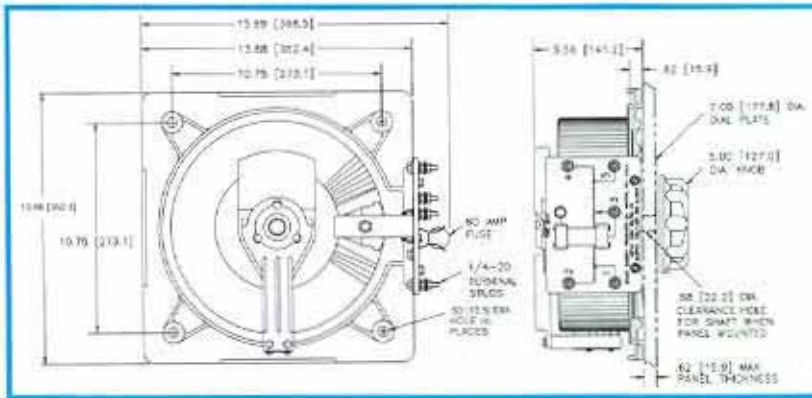

Manual Single, Uncased

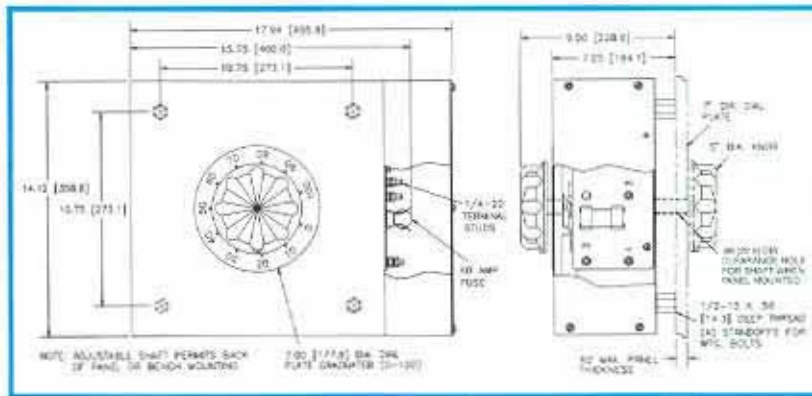

Manual Single, Cased

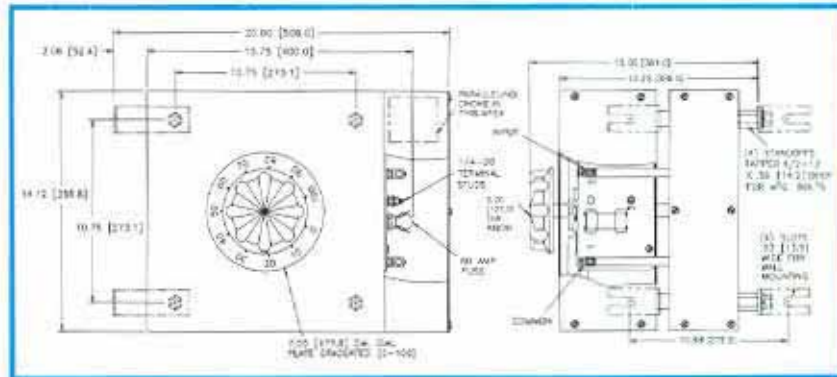

Manual Two-Ganged, Cased

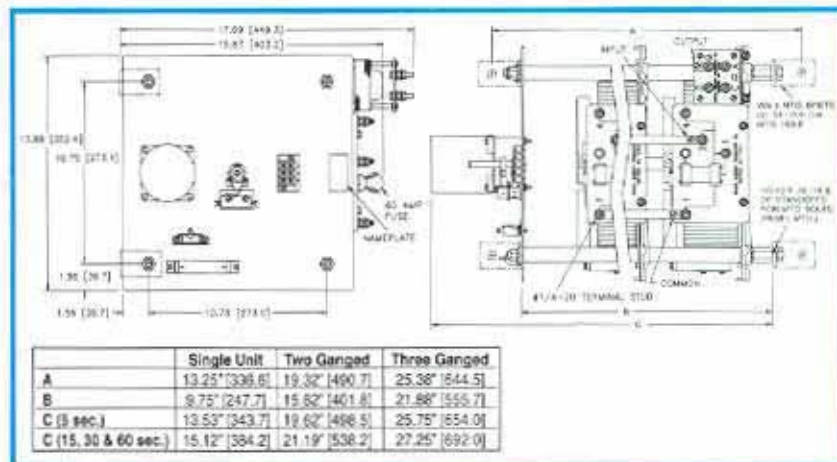

	Single Unit	Two Ganged	Three Ganged
A	13.25" [336.6]	19.32" [490.7]	25.38" [644.5]
B	8.75" [217.7]	15.62" [401.8]	21.88" [555.7]
C (8 sec.)	13.53" [343.7]	19.62" [498.5]	25.75" [654.0]
C (15, 30 & 60 sec.)	15.12" [384.2]	21.19" [538.2]	27.25" [692.0]

Motor Driven, Single, Two and Three-Ganged, Uncased

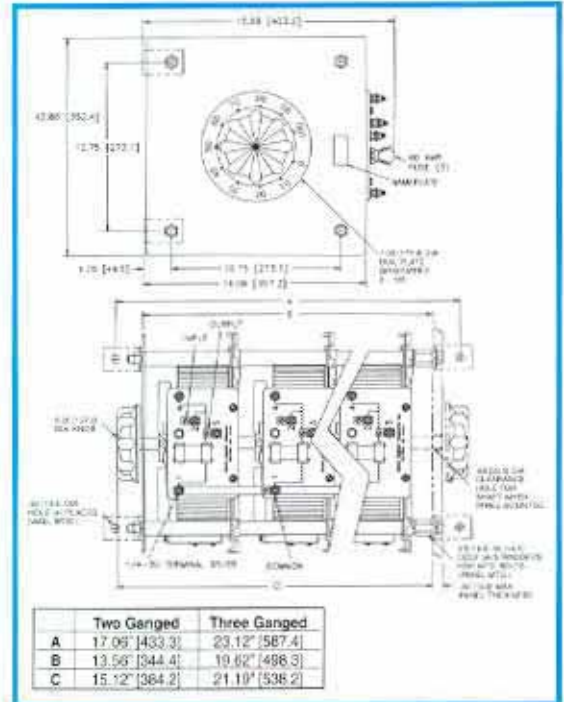

	Two Ganged	Three Ganged
A	17.06" [433.3]	23.12" [587.4]
B	13.56" [344.4]	19.62" [498.3]
C	15.12" [384.2]	21.19" [538.2]

Manual Two and Three-Ganged, Uncased

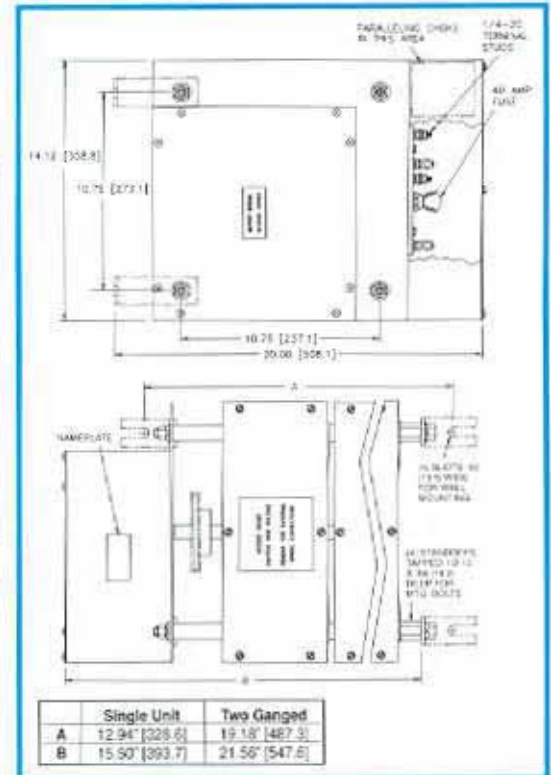

	Single Unit	Two Ganged
A	12.94" [328.6]	19.18" [487.3]
B	15.50" [393.7]	21.56" [547.6]

Motor Driven, Single and Two-Ganged, Cased

5000/6000 Series

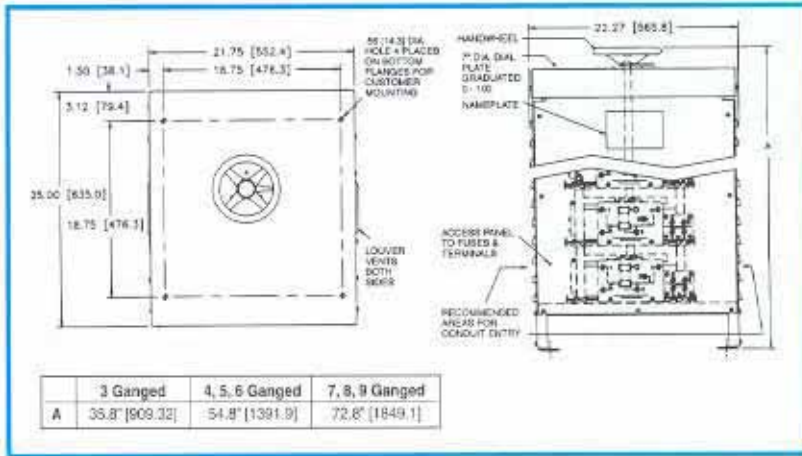

Manual Three to Nine-Ganged, Cased

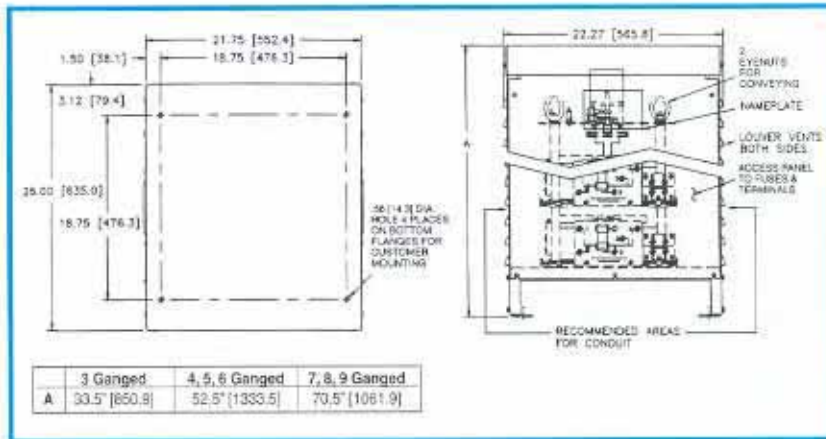

Motor-Driven Three to Nine-Ganged, Cased

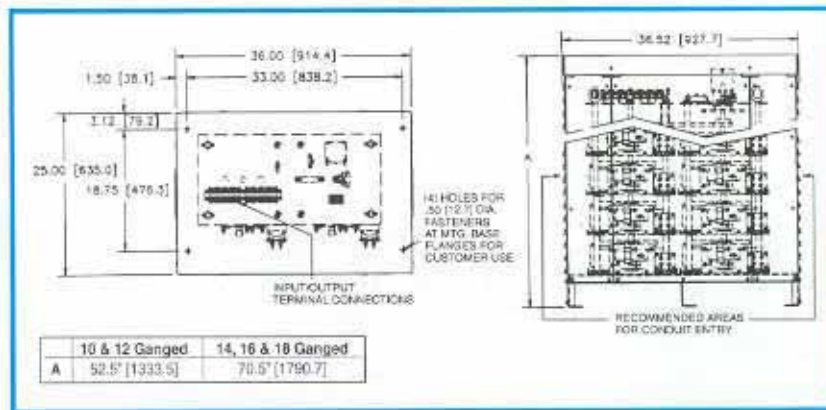

Motor-Driven 10, 12, 14, 16 & 18-Ganged Open Delta and Parallel, Cased

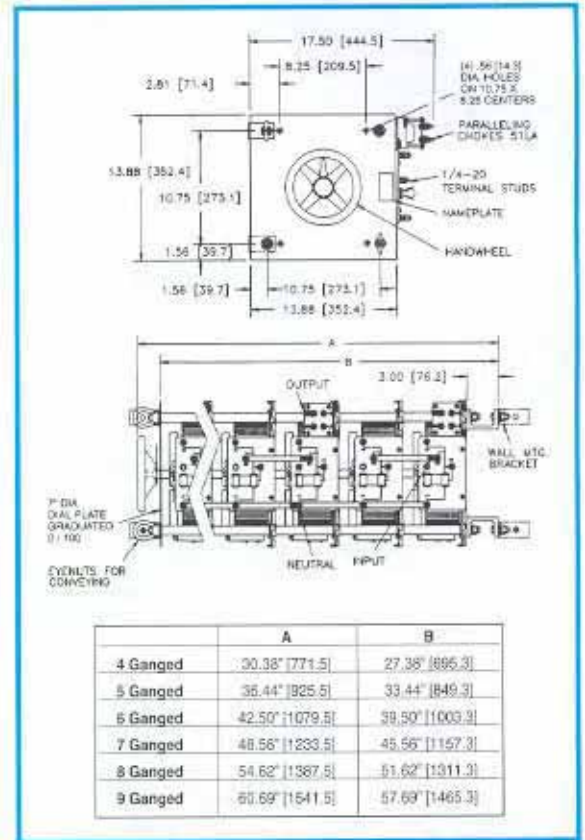

Manual Four to Nine-Ganged, Uncased



5021-3Y

6000 Series

Variable transformers of the 6011/6020 Series are designed for larger KVA requirements. The 6011, 120 volt unit is rated for constant current of 60 amperes. The 6020, 240 volt unit is rated at 35 amperes for constant current loads. All single units have coil tapping arrangements allowing output voltage from 0 to line voltage or 17% above line voltage.

Adjustable shaft design on manually operated models permits back-of-panel or bench mounting. Terminals are 1/4" screw type. For single and two ganged units, case styles are available in either "C" style, which encloses only the coil, or the "CT" style, which provides protective housing for both the coil and terminal board. Knockouts are provided in the terminal board

housing to accommodate conduit or cable connections. For three ganged and above, we offer our Nema 1, dripproof, fully front accessible "E" enclosure.

Motor-driven models are available from single thru 27 ganged assemblies; cased or uncased (identified with the prefix "M" in the part number. The synchronous motor is designed for operation on 120 volt, 50/60 Hertz lines and draws approximately 0.3 amperes. To meet a wide range of application requirements, standard motor speeds of 5, 15, 30 and 60 seconds are available depending upon the size of the variable transformer.

PART NUMBER		WIRING	INPUT		OUTPUT			SHAFT ROTATION FOR VOLTAGE INCREASE	TERMINAL CONNECTIONS For Increasing Voltage As Viewed from Rotor End		SCHEMATIC (Pg 8 & 9)	NET WEIGHT IN LBS. (MAX)	
MANUALLY OPERATED	MOTOR DRIVEN		VOLTS	HERTZ	VOLTS	MAX AMPS	MAX KVA		INPUT	OUTPUT		MAN-UAL	MOTOR DRIVEN
6011 6011C 6011CT	M6011 M6011C M6011CT	Single Phase	120	50/60	0-120	60	7.2	CW	2-4	2-3	19	67	88
					0-140	60	8.4	CCW	4-2	4-3			
								CW	2-5	2-3			
								CCW	4-1	4-3			
6020 6020C 6020CT	M6020 M6020C M6020CT	Single Phase	240	50/60	0-240	35	8.4	CW	2-4	2-3	19	63	84
					0-280	35	9.8	CCW	4-2	4-3			
								CW	2-5	2-3			
								CCW	4-1	4-3			
			120	50/60	0-280	35*15 V.D.	4.2†	CW	2-6	2-3			
								CCW	4-7	4-3			
6011-2D 6011C-2D 6011CT-2D	M6011-2D M6011C-2D M6011CT-2D	Three Phase Open Delta	120	50/60	0-120	60	12.5	CW	4-1-4	3-1-3	20 & 5	154	175
					0-140	60	14.5	CCW	2-1-2	3-1-3			
6011-2P 6011C-2P 6011CT-2P	M6011-2P M6011C-2P M6011CT-2P	Single Phase Parallel	120	50/60	0-120	120	14.4	CW	1-4	1-B	21	156	177
					0-140	120	16.8	CCW	1-2	1-B			
6011-2S 6011C-2S 6011CT-2S	M6011-2S M6011C-2S M6011CT-2S	Single Phase Series	240	50/60	0-240	60	14.4	CW	4-4	3-3	20 & 4	154	175
					0-280	60	16.8	CCW	2-2	3-3			
6020-2D 6020C-2D 6020CT-2D	M6020-2D M6020C-2D M6020CT-2D	Three Phase Open Delta	240	50/60	0-240	35	14.5	CW	4-1-4	3-1-3	20 & 5	146	167
					0-280	35	16.9	CCW	2-1-2	3-1-3			
								CW	5-1-5	3-1-3			
6020-2P 6020C-2P 6020CT-2P	M6020-2P M6020C-2P M6020CT-2P	Single Phase Parallel	240	50/60	0-240	70	16.8	CW	1-4	1-B	21	148	169
					0-280	70	19.6	CCW	1-2	1-B			
								CW	1-5	1-B			
6020-2S 6020C-2S 6020CT-2S	M6020-2S M6020C-2S M6020CT-2S	Single Phase Series	480	50/60	0-480	35	16.8	CW	4-4	3-3	20 & 4	146	167
					0-560	35	19.6	CCW	2-2	3-3			
								CW	5-5	3-3			
6011-3P 6011E-3P	M6011-3P M6011E-3P	Single Phase Parallel	120	50/60	0-120	180	21.6	CW	1-4	1-D	22	246	267
					0-140	180	25.2	CCW	1-2	1-D			
6011-3Y 6011E-3Y	M6011-3Y M6011E-3Y	Three Phase Wye	240	60	0-240	60	24.9	CW	4-4-4	3-3-3	20 & 6	242	263
					0-280	60	29.1	CCW	2-2-2	3-3-3			



6011



6011



6020

6000 Series

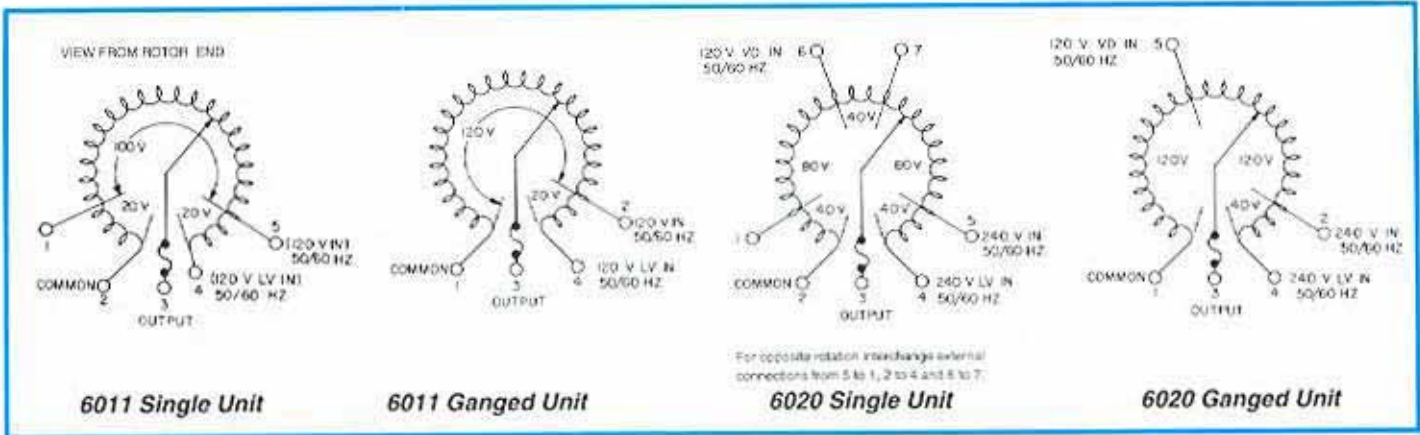

PART NUMBER		WIRING	INPUT		OUTPUT			SHAFT ROTATION FOR VOLTAGE INCREASE	TERMINAL CONNECTIONS For Increasing Voltage As Viewed from Rotor End		SCHEMATIC (Pg 8 & 9)	NET WEIGHT IN LBS. (MAX)	
MANUALLY OPERATED	MOTOR DRIVEN		VOLTS	HERTZ	VOLTS	MAX AMPS	MAX KVA		INPUT	OUTPUT		MANUAL	MOTOR DRIVEN
6020-3P 6020E-3P	M6020-3P M6020E-3P	Single Phase Parallel	240	50/60	0-240	105	25.2	CW	1-4	1-D	22	246	267
			120	50/60	0-280	105	29.4	CW	1-2	1-D			
6020-3Y 6020E-3Y	M6020-3Y M6020E-3Y	Three Phase Wye	480	50/60	0-480	35	29.1	CW	4-4-4	3-3-3	20 & 6	240	261
			240	60	0-560	35	33.9	CW	2-2-2	3-3-3			
6011-4D 6011E-4D	M6011-4D M6011E-4D	Three Phase Open Delta	120	50/60	0-120	120	24.9	CW	4-1-4	B-1-B	21 & 5	354	375
					0-140	120	29.1	CW	2-1-2	B-1-B			
6011-4P 6011E-4P	M6011-4P M6011E-4P	Single Phase Parallel	120	50/60	0-120	240	28.8	CW	1-4	1-D	22	356	377
					0-140	240	33.6	CW	1-2	1-D			
6011-4PS 6011E-4PS	M6011-4PS M6011E-4PS	Single Phase Series Parallel	240	50/60	0-240	120	28.8	CW	4-4	B-B	21 & 4	354	375
					0-280	120	33.6	CW	2-2	B-B			
6020-4D 6020E-4D	M6020-4D M6020E-4D	Three Phase Open Delta	240	50/60	0-240	70	29.1	CW	4-1-4	B-1-B	21 & 5	338	359
			120	50/60	0-280	70	33.9	CW	2-1-2	B-1-B			
6020-4P 6020E-4P	M6020-4P M6020E-4P	Single Phase Parallel	240	50/60	0-240	140	33.6	CW	1-4	1-D	22	340	361
			120	50/60	0-280	140	39.2	CW	1-2	1-D			
6020-4PS 6020E-4PS	M6020-4PS M6020E-4PS	Single Phase Series Parallel	480	50/60	0-480	70	33.6	CW	4-4	B-B	21 & 4	338	359
			240	50/60	0-560	70	39.2	CW	2-2	B-B			
6011-5P 6011E-5P	M6011-5P M6011E-5P	Single Phase Parallel	120	50/60	0-120	300	36.0	CW	1-4	1-D	22	450	471
					0-140	300	42.0	CW	1-2	1-D			
6020-5P 6020E-5P	M6020-5P M6020E-5P	Single Phase Parallel	240	50/60	0-240	175	42.0	CW	1-4	1-D	22	430	451
			120	50/60	0-280	175	49.0	CW	1-2	1-D			
6011-6D 6011E-6D	M6011-6D M6011E-6D	Three Phase Open Delta	120	50/60	0-120	180	37.4	CW	4-1-4	D-1-D	22 & 5	541	562
					0-140	180	43.6	CW	2-1-2	D-1-D			
6011-6P 6011E-6P	M6011-6P M6011E-6P	Single Phase Parallel	120	50/60	0-120	360	43.2	CW	1-4	1-D	22	543	564
					0-140	360	50.4	CW	1-2	1-D			
6011-6PS 6011E-6PS	M6011-6PS M6011E-6PS	Single Phase Series Parallel	240	50/60	0-240	180	43.2	CW	4-4	D-D	22 & 4	541	562
					0-280	180	50.4	CW	2-2	D-D			
6011-6Y 6011E-6Y	M6011-6Y M6011E-6Y	Three Phase Wye	240	60	0-240	120	49.8	CW	4-4-4	B-B-B	21 & 6	539	560
					0-280	120	58.1	CW	2-2-2	B-B-B			

6000 Series

PART NUMBER		WIRING	INPUT		OUTPUT			SHAFT ROTATION FOR VOLTAGE INCREASE	TERMINAL CONNECTIONS For Increasing Voltage As Viewed from Rotor End		SCHEMATIC (Pg 8 & 9)	NET WEIGHT IN LBS. (MAX)	
MANUALLY OPERATED	MOTOR DRIVEN		VOLTS	HERTZ	VOLTS	MAX AMPS	MAX KVA		INPUT	OUTPUT		MANUAL	MOTOR DRIVEN
6020-6D 6020E-6D	M6020-6D M6020E-6D	Three Phase Open Delta	240	50/60	0-240	105	43.6	CW	4-1-4	D-1-D	22 & 5	517	538
					0-280	105	50.9	CW	2-1-2	D-1-D			
			120	50/60	0-280	105*-45 V.D.	21.8†	CW	5-1-5	D-1-D			
6020-6P 6020E-6P	M6020-6P M6020E-6P	Single Phase Parallel	240	50/60	0-240	210	50.4	CW	1-4	1-D	22	489	510
					0-280	210	58.8	CW	1-2	1-D			
			120	50/60	0-280	210*-90 V.D.	25.2†	CW	1-5	1-D			
6020-6PS 6020E-6PS	M6020-6PS M6020E-6PS	Single Phase Series Parallel	480	50/60	0-480	105	50.4	CW	4-4	D-D	22 & 4	487	508
					0-560	105	58.8	CW	2-2	D-D			
			240	50/60	0-560	105*-45 V.D.	25.2†	CW	5-5	D-D			
6020-6Y 6020E-6Y	M6020-6Y M6020E-6Y	Three Phase Wye	480	50/60	0-480	70	58.1	CW	4-4-4	B-B-B	21 & 6	485	506
				60	0-560	70	67.8	CW	2-2-2	B-B-B			
			240	60	0-560	70*-30 V.D.	29.1†	CW	5-5-5	B-B-B			
6011-7P 6011E-7P	M6011-7P M6011E-7P	Single Phase Parallel	120	50/60	0-120	420	50.4	CW	1-4	1-D	22	633	654
					0-140	420	58.8	CW	1-2	1-D			
6020-7P 6020E-7P	M6020-7P M6020E-7P	Single Phase Parallel	240	50/60	0-240	245	58.8	CW	1-4	1-D	22	598	618
					0-280	245	68.6	CW	1-2	1-D			
			120	50/60	0-280	245*-105 V.D.	29.4†	CW	1-5	1-D			
6011-8D 6011E-8D	M6011-8D M6011E-8D	Three Phase Open Delta	120	50/60	0-120	240	49.8	CW	4-1-4	D-1-D	22 & 5	720	741
					0-140	240	58.1	CW	2-1-2	D-1-D			
6011-8P 6011E-8P	M6011-8P M6011E-8P	Single Phase Parallel	120	50/60	0-120	480	57.6	CW	1-4	1-D	22	722	743
					0-140	480	67.2	CW	1-2	1-D			
6011-8PS 6011E-8PS	M6011-8PS M6011E-8PS	Single Phase Series Parallel	240	50/60	0-240	240	57.6	CW	4-4	D-D	22 & 4	720	741
					0-280	240	67.2	CW	2-2	D-D			
6020-8D 6020E-8D	M6020-8D M6020E-8D	Three Phase Open Delta	240	50/60	0-240	140	58.1	CW	4-1-4	D-1-D	22 & 5	688	709
					0-280	140	67.8	CW	2-1-2	D-1-D			
			120	50/60	0-280	140*-60 V.D.	29.1†	CW	5-1-5	D-1-D			
6020-8P 6020E-8P	M6020-8P M6020E-8P	Single Phase Parallel	240	50/60	0-240	280	67.2	CW	1-4	1-D	22	690	711
					0-280	280	78.4	CW	1-2	1-D			
			120	50/60	0-280	280*-120 V.D.	33.6†	CW	1-5	1-D			
6020-8PS 6020E-8PS	M6020-8PS M6020E-8PS	Single Phase Series Parallel	480	50/60	0-480	140	67.2	CW	4-4	D-D	22 & 4	688	709
					0-560	140	78.4	CW	2-2	D-D			
			240	50/60	0-560	140*-60 V.D.	33.6†	CW	5-5	D-D			
6011-9P 6011E-9P	M6011-9P M6011E-9P	Single Phase Parallel	120	50/60	0-120	540	64.8	CW	1-4	1-D	22	811	832
					0-140	540	75.6	CW	1-2	1-D			
6011-9Y 6011E-9Y	M6011-9Y M6011E-9Y	Three Phase Wye	240	60	0-240	180	74.7	CW	4-4-4	D-D-D	22 & 6	807	828
					0-280	180	87.2	CW	2-2-2	D-D-D			
6020-9P 6020E-9P	M6020-9P M6020E-9P	Single Phase Parallel	240	50/60	0-240	315	75.6	CW	1-4	1-D	22	775	796
					0-280	315	88.2	CW	1-2	1-D			
			120	50/60	0-280	315*-135 V.D.	37.8†	CW	1-5	1-D			
6020-9Y 6020E-9Y	M6020-9Y M6020E-9Y	Three Phase Wye	480	50/60	0-480	105	87.2	CW	4-4-4	D-D-D	22 & 6	771	792
				60	0-560	105	101.7	CW	2-2-2	D-D-D			
			240	60	0-560	105*-45 V.D.	43.6†	CW	5-5-5	D-D-D			
—	M6011-10D M6011E-10D	Three Phase Open Delta	120	50/60	0-120	300	62.3	CW	4-1-4	D-1-D	22 & 5	—	912
					0-140	300	72.7	CW	2-1-2	D-1-D			
—	M6011-10PS M6011E-10PS	Single Phase Series Parallel	240	50/60	0-240	300	72.0	CW	4-4	D-D	22 & 4	—	912
					0-280	300	84.0	CW	2-2	D-D			
—	M6020-10D M6020E-10D	Three Phase Open Delta	240	50/60	0-240	175	72.7	CW	4-1-4	D-1-D	22 & 5	—	912
					0-280	175	84.8	CW	2-1-2	D-1-D			
			120	50/60	0-280	175*-75 V.D.	36.3†	CW	5-1-5	D-1-D			

6000 Series

PART NUMBER		WIRING	INPUT		OUTPUT			SHAFT ROTATION FOR VOLTAGE INCREASE	TERMINAL CONNECTIONS For Increasing Voltage As Viewed from Rotor End		SCHEMATIC (Pg 8 & 9)	NET WEIGHT IN LBS. (MAX)	
MANUALLY OPERATED	MOTOR DRIVEN		VOLTS	HERTZ	VOLTS	MAX AMPS	MAX KVA		INPUT	OUTPUT		MANUAL	MOTOR DRIVEN
—	M6020-10PS M6020E-10PS	Single Phase Series Parallel	480	50/60	0-480	175	84.0	CW	4-4	D-D	22 & 4	—	872
			240	50/60	0-560	175	98.0	CW	2-2	D-D			
—	M6011-12D M6011E-12D	Three Phase Open Delta	120	50/60	0-120	360	74.7	CW	4-1-4	D-1-D	22 & 5	—	1060
			0-140	360	87.2	CW	2-1-2	D-1-D					
—	M6011-12PS M6011E-12PS	Single Phase Series Parallel	240	50/60	0-240	360	86.4	CW	4-4	D-D	22 & 4	—	1060
			0-280	360	100.8	CW	2-2	D-D					
—	M6020-12D M6020E-12D	Three Phase Open Delta	240	50/60	0-240	210	87.2	CW	4-1-4	D-1-D	22 & 5	—	1012
			0-280	210	101.7	CW	2-1-2	D-1-D					
—	M6020-12PS M6020E-12PS	Single Phase Series Parallel	480	50/60	0-480	210	100.8	CW	4-4	D-D	22 & 4	—	1012
			0-560	210	117.6	CW	2-2	D-D					
—	M6011-14D M6011E-14D	Three Phase Open Delta	120	50/60	0-120	420	87.2	CW	4-1-4	D-1-D	22 & 5	—	1237
			0-140	420	101.7	CW	2-1-2	D-1-D					
—	M6011-14PS M6011E-14PS	Single Phase Series Parallel	240	50/60	0-240	420	100.8	CW	4-4	D-D	22 & 4	—	1237
			0-280	420	117.6	CW	2-2	D-D					
—	M6020-14D M6020E-14D	Three Phase Open Delta	240	50/60	0-240	245	101.7	CW	4-1-4	D-1-D	22 & 5	—	1181
			0-280	245	118.7	CW	2-1-2	D-1-D					
—	M6020-14PS M6020E-14PS	Single Phase Series Parallel	480	50/60	0-480	245	117.6	CW	4-4	D-D	22 & 4	—	1181
			0-560	245	137.2	CW	2-2	D-D					
—	M6011-16D M6011E-16D	Three Phase Open Delta	120	50/60	0-120	480	99.6	CW	4-1-4	D-1-D	22 & 5	—	1414
			0-140	480	116.3	CW	2-1-2	D-1-D					
—	M6011-16PS M6011E-16PS	Single Phase Series Parallel	240	50/60	0-240	480	115.2	CW	4-4	D-D	22 & 4	—	1414
			0-280	480	134.4	CW	2-2	D-D					
—	M6020-16D M6020E-16D	Three Phase Open Delta	240	50/60	0-240	280	116.3	CW	4-1-4	D-1-D	22 & 5	—	1350
			0-280	280	135.6	CW	2-1-2	D-1-D					
—	M6020-16PS M6020E-16PS	Single Phase Series Parallel	480	50/60	0-480	280	134.4	CW	4-4	D-D	22 & 4	—	1350
			0-560	280	156.8	CW	2-2	D-D					
—	M6011-18D M6011E-18D	Three Phase Open Delta	120	50/60	0-120	540	112.1	CW	4-1-4	D-1-D	22 & 5	—	1597
			0-140	540	130.8	CW	2-1-2	D-1-D					
—	M6011-18PS M6011E-18PS	Single Phase Series Parallel	240	50/60	0-240	540	129.6	CW	4-4	D-D	22 & 4	—	1597
			0-280	540	151.2	CW	2-2	D-D					
—	M6020-18D M6020E-18D	Three Phase Open Delta	240	50/60	0-240	315	130.8	CW	4-1-4	D-1-D	22 & 5	—	1525
			0-280	315	152.6	CW	2-1-2	D-1-D					
—	M6020-18PS M6020E-18PS	Single Phase Series Parallel	480	50/60	0-480	315	151.2	CW	4-4	D-D	22 & 4	—	1525
			0-560	315	176.4	CW	2-2	D-D					
—	M6011-12Y M6011E-12Y	Three Phase Wye	240	60	0-240	240	99.6	CW	4-4-4	D-D-D	22 & 6	—	1062
			0-280	240	116.3	CW	2-2-2	D-D-D					

6000 Series

PART NUMBER		WIRING	INPUT		OUTPUT			SHAFT ROTATION FOR VOLTAGE INCREASE	TERMINAL CONNECTIONS For Increasing Voltage As Viewed from Rotor End		SCHE- MATIC (Pg 8 & 9)	NET WEIGHT IN LBS. (MAX)	
MANUALLY OPERATED	MOTOR DRIVEN		VOLTS	HERTZ	VOLTS	MAX AMPS	MAX KVA		INPUT	OUTPUT		MAN- UAL	MOTOR DRIVEN
—	M6020-12Y M6020E-12Y	Three Phase Wye	480	50/60	0-480	140	116.3	CW	4-4-4	D-D-D	22 & 6	—	1014
				60	0-560	140	135.6	CW	2-2-2	D-D-D			
				240	60	0-560	140*60 V.D.	58.1‡	CW	5-5-5			
—	M6011-15Y M6011E-15Y	Three Phase Wye	240	60	0-240	300	124.6	CW	4-4-4	D-D-D	22 & 6	—	1329
					0-280	300	145.3	CW	2-2-2	D-D-D			
—	M6020-15Y M6020E-15Y	Three Phase Wye	480	50/60	0-480	175	145.3	CW	4-4-4	D-D-D	22 & 6	—	1269
				60	0-560	175	169.5	CW	2-2-2	D-D-D			
				240	60	0-560	175*75 V.D.	72.7‡	CW	5-5-5			
—	M6011-18Y M6011E-18Y	Three Phase Wye	240	60	0-240	360	149.5	CW	4-4-4	D-D-D	22 & 6	—	1595
					0-280	360	174.4	CW	2-2-2	D-D-D			
—	M6020-18Y M6020E-18Y	Three Phase Wye	480	50/60	0-480	210	174.6	CW	4-4-4	D-D-D	22 & 6	—	1523
				60	0-560	210	203.4	CW	2-2-2	D-D-D			
				240	60	0-560	210*90 V.D.	87.2‡	CW	5-5-5			
—	M6011-21Y M6011E-21Y	Three Phase Wye	240	60	0-240	420	174.4	CW	4-4-4	D-D-D	22 & 6	—	1864
					0-280	420	203.4	CW	2-2-2	D-D-D			
—	M6020-21Y M6020E-21Y	Three Phase Wye	480	50/60	0-480	245	203.4	CW	4-4-4	D-D-D	22 & 6	—	1780
				60	0-560	245	237.4	CW	2-2-2	D-D-D			
				240	60	0-560	245*105 V.D.	101.7‡	CW	5-5-5			
—	M6011-24Y M6011E-24Y	Three Phase Wye	240	60	0-240	480	199.3	CW	4-4-4	D-D-D	22 & 6	—	2132
					0-280	480	232.5	CW	2-2-2	D-D-D			
—	M6020-24Y M6020E-24Y	Three Phase Wye	480	50/60	0-480	280	232.5	CW	4-4-4	D-D-D	22 & 6	—	2036
				60	0-560	280	271.3	CW	2-2-2	D-D-D			
				240	60	0-560	280*120 V.D.	116.3‡	CW	5-5-5			
—	M6011-27Y M6011E-27Y	Three Phase Wye	240	60	0-240	540	224.2	CW	4-4-4	D-D-D	22 & 6	—	2401
					0-280	540	261.6	CW	2-2-2	D-D-D			
—	M6020-27Y M6020E-27Y	Three Phase Wye	480	50/60	0-480	315	261.6	CW	4-4-4	D-D-D	22 & 6	—	2293
				60	0-560	315	305.2	CW	2-2-2	D-D-D			
				240	60	0-560	315*135 V.D.	130.8‡	CW	5-5-5			

* Maximum output current in output voltage range from 0 to 25 percent above line voltage. At higher output voltages, output current must be reduced according to rating curve Figure B, page 6.

‡ Maximum KVA at maximum output and corresponding de-rated current. Maximum KVA at lower output voltages may be calculated from rating curve Figure B, page 6.

V.D. Voltage Doubler

Isolated Series

The isolated variable transformer has a separate primary winding which is electrically isolated from the secondary or output winding. Either side of the output can be grounded independently of the supply line, making them safe for all industrial, classroom, and laboratory applications where an isolated output without a common ground connection is required.

The isolated units are designed for 120V, 50/60Hz input, and

the output voltages will vary from 0 - 122% of the input for a 0-140 volt output. Three sizes are available — J201B rated at 2 amps, J401 rated at 4 amps, and J901 rated at 9 amps. These units are each available in the uncased design for bench or back-of-panel mounting, and the shaft is adjustable to accommodate various panel thicknesses. Dial plates supplied are 0-100%. The J201B and J401 are also provided in the 3PN plug and cord series with and without voltmeter or ammeter.

MODEL	WIRING	INPUT		OUTPUT				SHAFT ROTATION For Voltage Increase	TERMINAL CONNECTIONS (For increasing voltage) As viewed from Base End			NET WT. LBS.	
		VOLTS	HERTZ	VOLTS	CONSTANT CURRENT LOAD		CONSTANT IMPEDANCE LOAD		INPUT	JUMPER	OUTPUT		
					MAX AMPS	MAX KVA	MAX AMPS						MAX KVA
J201B	Isolated	120	50/60	0-140	2	0.28	—	—	CW CCW	1-2 1-2	— —	3-5 3-4	8 1/2
	Non-Isolated			0-120	5	0.60	—	—	CW CCW	4-5 4-5	— —	3-5 3-4	
	Voltage Doubler			120-260	4.5	0.52	—	—	CW CCW	1-2 1-2	1-5 2-4	3-2 3-1	
	Series			110-240	4.5	1.08	—	—	CW CCW	1-5 1-5	2-4 2-4	3-2 3-1	
J401	Isolated	120	50/60	0-140	4	0.56	—	—	CW CCW	1-2 1-2	— —	3-5 3-4	14 3/4
	Non-Isolated			0-120	10	1.20	—	—	CW CCW	4-5 4-5	— —	3-5 3-4	
	Voltage Doubler			120-260	9	1.04	—	—	CW CCW	1-2 1-2	1-5 2-4	3-2 3-1	
	Series			110-240	9	2.16	—	—	CW CCW	1-5 1-5	2-4 2-4	3-2 3-1	
J901	Isolated	120	50/60	0-140	9	1.26	—	—	CW CCW	1-2 1-2	— —	3-5 3-4	26 3/4
	Non-Isolated			0-120	25	3.00	—	—	CW CCW	4-5 4-5	— —	3-5 3-4	
	Voltage Doubler			120-260	20	2.34	—	—	CW CCW	1-2 1-2	1-5 2-4	3-2 3-1	
	Series			110-240	20	4.80	—	—	CW CCW	1-5 1-5	2-4 2-4	3-2 3-1	

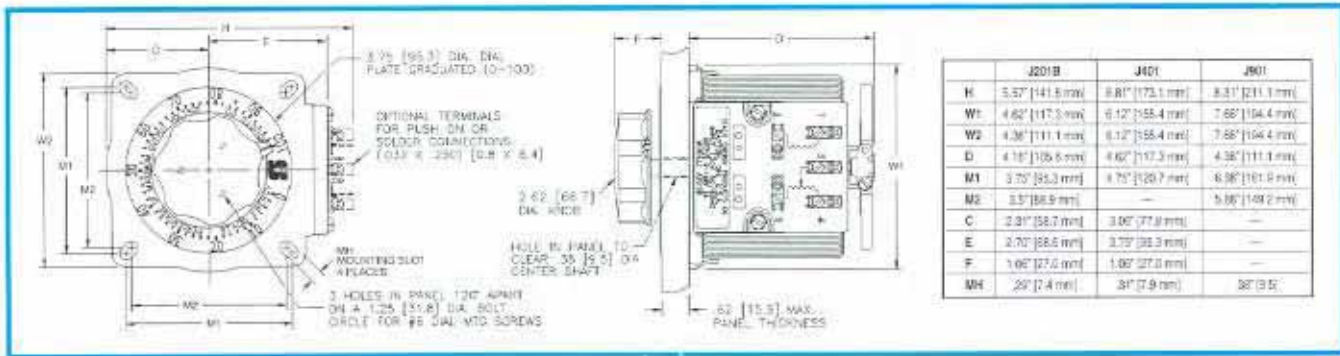

J201B



Enclosed Cord and Plug Series

3PN Series

The cased plug-in models feature a ventilated steel case, input line cord and plug, fused NEMA rated output receptacle, and an illuminated on/off switch. They are connected for output voltage increase with a clockwise rotation, and the dials are graduated from 0-100% of the voltage setting.

For application flexibility, two field modification kits have been added. The 3PN-MK kit allows either the 3PN221B or

3PN501B to be wall, bench top, or machine mounted. The 3PN-SK kit provides an adjustable voltage stop for either the 3PN1000, 3PN1200, or 3PN1500 series.

Cased plug-in models are also available with a pivot and jewel AC voltmeter or ammeter (with $\pm 5\%$ full scale accuracy) conveniently located atop the enclosure for easy readout.

VOLTS	PART NO.	INPUT		OUTPUT				SCHE-MATIC (Pg. 8 & 9)	NET WT LBS
		HERTZ	VOLTS	CONSTANT CURRENT LOAD		CONSTANT IMPEDANCE LOAD			
				MAX AMPS	MAX KVA	MAX AMPS	MAX KVA		
120	3PN221B	60	0-132	2.50	0.33	—	—	3	3
	3PN501B	50/60	0-140	5.0 †	0.70	—	—	3	7 3/4
	3PN1010B	50/60	0-140	10 †	1.4	—	—	3	10 1/4
	3PN1010BA 3PN1010BV	50/60	0-140	10 †	1.4	w/Ammeter w/Voltmeter		9	10 1/4
	3PN1210B	60	0-120	12 †	1.44	15	1.80	11	10 1/4
	3PN1510B	50/60	0-140	15 †	2.10	—	—	3	18
	3PN1510BA 3PN1510BV	50/60	0-140	15 †	2.10	w/Ammeter w/Voltmeter		9	18
240	3PN2210B	50/60	0-140	22 †	3.08	—	—	3	24 1/4
	3PN1020B	50/60	0-280	3.5 †	0.98	—	—	3	10 1/4
	3PN1020BA 3PN1020BV	50/60	0-280	3.5 †	0.98	w/Ammeter w/Voltmeter		9	10 1/4
	3PN1220B	60	0-240	5.0 †	1.20	7.0	1.68	11	10 1/4
	3PN1520B	50/60	0-280	9.5 †	2.66	—	—	3	22
	3PN2520B	50/60	0-280	10 †	2.80	—	—	3	24 1/4

† Unit is fused for the constant current rating at the factory.



3PN221B,
3PN501B



3PN-MK-Kit



3PN1010B



3PN-SK-Kit

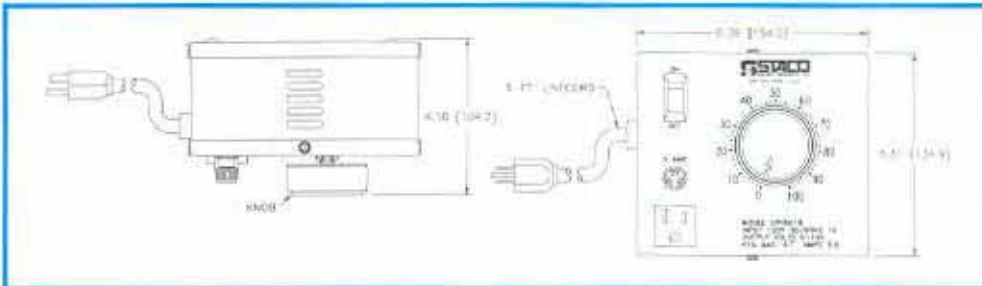

3PN221B, 3PN501B

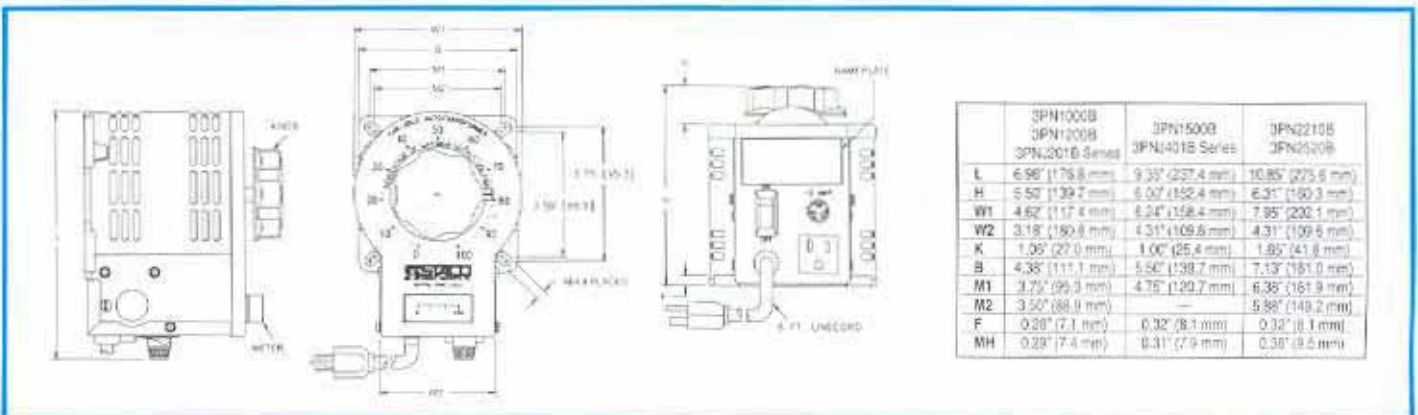

3PN1010BV & 3PNJ201BV, A Cord and Plug

	3PN1000B 3PN1200B 3PN1500B Series	3PN1500B 3PN1200B Series	3PN2210B 3PN2520B
L	6.96" (176.8 mm)	9.35" (237.4 mm)	10.85" (275.6 mm)
H	6.50" (165.1 mm)	6.07" (154.4 mm)	6.31" (160.3 mm)
W1	4.62" (117.4 mm)	6.24" (158.4 mm)	7.95" (202.1 mm)
W2	3.18" (80.8 mm)	4.31" (109.6 mm)	4.31" (109.6 mm)
K	1.05" (26.7 mm)	1.00" (25.4 mm)	1.85" (46.8 mm)
B	4.38" (111.1 mm)	5.60" (141.8 mm)	7.13" (181.0 mm)
M1	3.25" (82.5 mm)	4.75" (120.7 mm)	6.35" (161.9 mm)
M2	3.50" (88.9 mm)	—	5.88" (149.2 mm)
F	0.20" (5.1 mm)	0.32" (8.1 mm)	0.32" (8.1 mm)
MH	0.28" (7.1 mm)	0.31" (7.9 mm)	0.36" (9.1 mm)

Enclosed Cord and Plug Series



3PN1510B



3PN2210B



3PN1010BV

L Series

These fully enclosed variable voltage controls provide protection from physical abuse, chemical spills, and other hazards. They are ideal for about every laboratory application including control of electric heating elements, lighting, electric motor speed or power, and electrical testing. Output voltage is controlled with a large slip resistant knob which increases the voltage linearly as it is turned clockwise.

In addition to portable use, the rugged, flat-topped enclosure has a slot at top rear for wall mounting. All models include line cord and plug, receptacle, switch, pilot lamp and fuse (the metered unit includes a circuit breaker). A voltmeter and ammeter are included in the L1010VA. The meter accuracy is $\pm 3\%$, and a meter range selector is used to increase reading resolution.

MODEL NUMBER*	LINE VOLTAGE	OUTPUT		DIMENSIONS			WEIGHT (LBS.)
		VOLTAGE	CURRENT	HEIGHT	WIDTH	DEPTH	
L221	120	0-132	1.75	6.31" [160.4]	5.00" [127.0]	4.25" [108.0]	3.5
L501			4.5	7.75" [197.0]	5.38" [136.5]	5.62" [142.9]	7.25
L1010		0-140	10.0	9.41" [238.9]	6.50" [165.1]	6.25" [158.8]	12.25
L1010VA			10.0	12.38" [314.3]	10.75" [273.0]	6.25" [158.8]	17.75

* All models 50/60 Hz operation except L221, which is 60 Hz only.

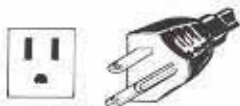

3PN 120-VOLT TYPES
3PN (120)

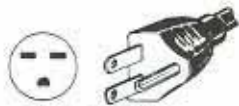

3PN 240-VOLT TYPES
3PN (240)

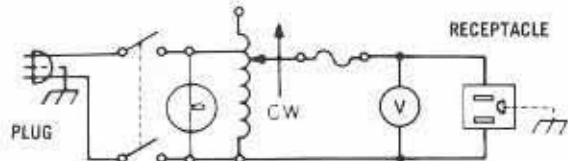

Variable Transformer Controllers

FRC-20 Controller

The STACO FRC-20 Controller is designed to position and regulate any STACO motor driven variable transformer; and, can be controlled with a

0-5 VDC or 4-20 Ma set point, a 1 k ohm potentiometer, or a fixed resistor network.

It maintains a full range regulation of 0.5% , and a limited range regulation of 0.25%. This unit is field configurable for feedback voltages up to 600 Vac, full range/limited range, and type of control. Each FRC-20 includes a 1 amp motor supply fuse and a set point supply trim potentiometer. It is a compact package and can be easily mounted on the motor plate or inside an enclosure. Contact factory for current and other feedback alternates.

- 0.5% full range regulation
- 0.25% limited range regulation
- 0-5 VDC or 4-20 Ma set point control
- 1 k ohm potentiometer or fixed resistor network control
- Full or limited range control
- Small size
- Ease in mounting
- Up to 600 Vac feedback voltage operation
- Current regulation

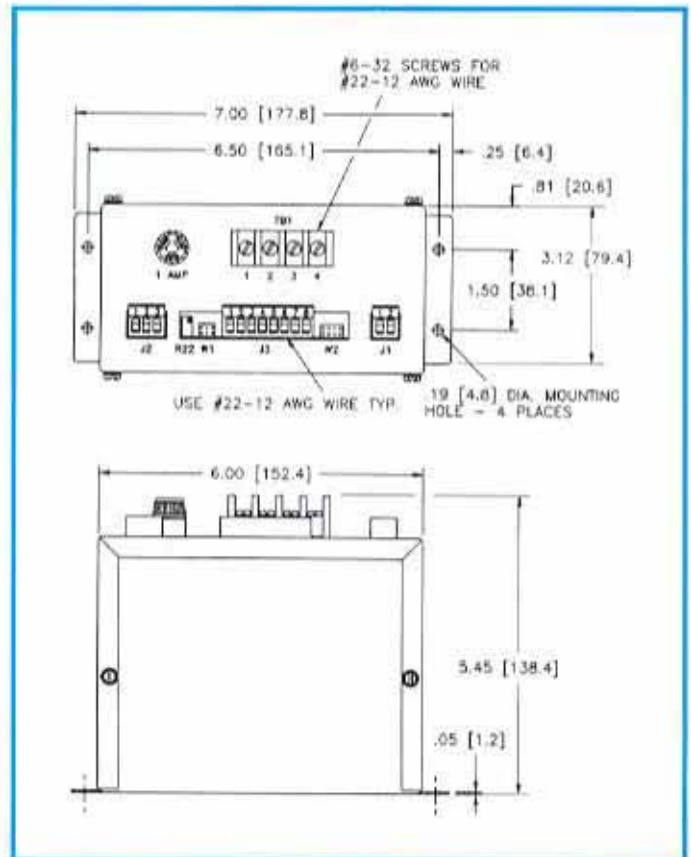
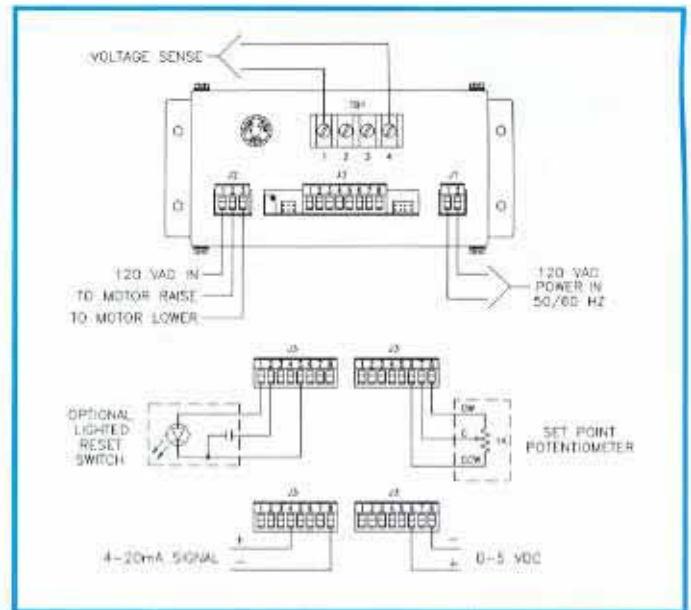

Variable Transformer Controllers

MP Series

The MP Series microprocessor based controller controls, regulates, and provides ease in interfacing a computer or process controller with a STACO motor-driven variable transformer.

It can be controlled with the microterminal, process control set point, or a bi-directional communications port such as RS-232 or RS-422. The variable transformer regulation is maintained at ± 0.5 volts. The MP controller is available with one, two or three channels for control of up to three motorized variable transformers or individual phase control of a three phase unit.

The microcontroller is capable of operating in several different operational modes with selectable control ranges - tunable for various motor speeds, output voltage ramping, serial/analog set point selection, and feed back voltage range.

Controller Advantages

- Intelligent microprocessor based
- Controls variable voltage transformer regulation to within ± 0.5 volts
- Multi-channeled unit enables control of one, two, or three individual motorized variable transformers or each phase of a three phase unit
- LCD display of feedback signals and set points
- Available with standard analog control signals (0-1 mA, 4-20 mA, 0-50 mVDC, 0-10 VDC) for set point and control functions
- Available with standard bi-directional RS-232, RS-422, IEEE-488 communication ports for set point and control functions
- Multiple set points, ramping, and dwell times available
- Heavy duty wall mountable NEMA 12 style enclosure
- Control of the unit can be local, at a remote location, or both



Controller with Enclosure Mounted Microterminal Option



Rack Mounted Microprocessor Controller

- Battery back-up RAM retains data if power is lost
- Microterminal available for remote or stand-alone monitoring and control
- User programmable to accept peak-to-peak, rms, or average AC feedback signals
- Phase loss detection, logic level signal

Available Options

- Bi-directional RS-232, RS-422, IEEE-488 communication ports
- Single, double, or triple channel feedback
- Process control set point (0-50mVDC, 0-10VDC, 0-1mA & 4-20mA)
- Optical isolation of control and feedback inputs for reduced noise interference
- Panel mounted microterminal for local control and monitoring
- Phase loss detection

Available Options

Options	Suffix
Process Control Set point	S
Enclosure mounted MICRO TERMINAL	T
Microterminal only, for remote mounting	MT
Phase loss detection	L
Optical Isolated Inputs (optical isolation reduces noise interference)	I
RS-232 Communications Port	2
RS-422 Communications Port	4
IEEE-488 Communications Port	8

Typical Examples

A Single channel controller with an enclosure mounted terminal and process control set point — *Specify MPAST*

A Single channel controller with an enclosure mounted terminal and an RS-232 port — *Specify MPA2T*

A three channel controller for control of 3 ϕ bank of variable transformers, with three motors for individual phase control plus RS-422 port — *Specify MPC4*

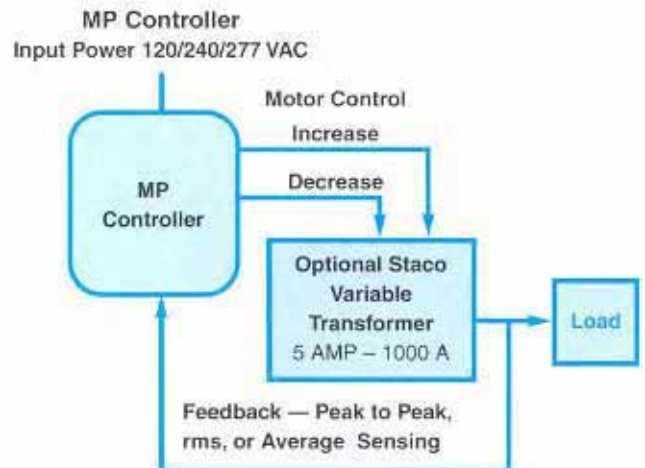

“Quick Step” Motorized Variable Transformers

The Quick-Step is a positioner and a regulator. It is self-contained and consists of a stepper motor driven, microprocessor controlled, full range variable transformer with a 0 to 100%

adjustable output voltage range. The “Quick-Step” is shipped fully assembled, factory wired and tested, ready to be installed. The full range correction rate is less than one second.

TYPE	STYLE	INPUT VOLTAGE	OUTPUT			DIMENSIONS (INCHES)			WEIGHT (LBS)
			VOLTAGE	AMPS	kVA	H	W	D	
SD291	Open Frame	120V 50/60 Hz	0-120/132	3.0	0.40	4.94	5.00	3.75	13
SD511			5.0	0.70	5.00	5.84	4.16	15	
SD1010			0-120/140	10.0	1.40	8.06	6.62	5.34	20
SD1510				15.0	2.10	8.41	7.88	6.80	22
SD2510				25.0	3.50	8.40	9.39	8.29	26



Note: Limited output range and 240 volt input models are available in designs to meet special application needs. Contact factory for specifications and application information.

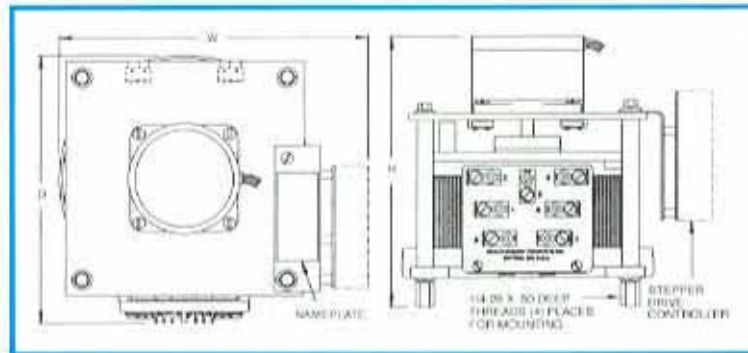
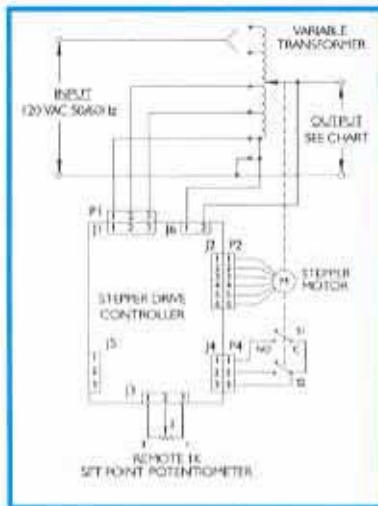

Paralleling Chokes

Paralleling chokes, or reactors are used to force equal distribution or current where two or more variable transformers are ganged in parallel circuits. When variable transformers are connected in parallel without the use of paralleling chokes, slight differences in brush contact conditions will result in unequal loading of the individual units causing a possible overload condition.

Parallel operation of ganged units (smaller than the 2510/2520 series) is not recommended because it is usually more economical to handle rated loads with the capacity of larger single units.

Schematics figures 16 and 17 on page 9 illustrate the use of the four terminal style chokes available from Staco. Four designs of chokes are offered. Type 51LA and 51LAC are for 120 volt operation. Type 51LAC is used in 5011 “CT” and 6011 “CT” style units and is recommended for use with models of the 2510 Series when hooked in parallel.

Type 52LA and 52LAC are for 240 volt operation. Type 52LAC is used in the 5021 “CT” and 6020 “CT” style units and is recommended for use with models of the 2520 when hooked in parallel. Types 51LA and 52LA are used on all uncased models of the 5011/5021 and 6011/6020 Series when parallel wired at the factory. Complete details are shown.

Chokes need not be ordered separately on ganged assemblies of the 5011/5021 and 6011/6020 Series because each unit is wired complete with all necessary chokes and connecting wiring.

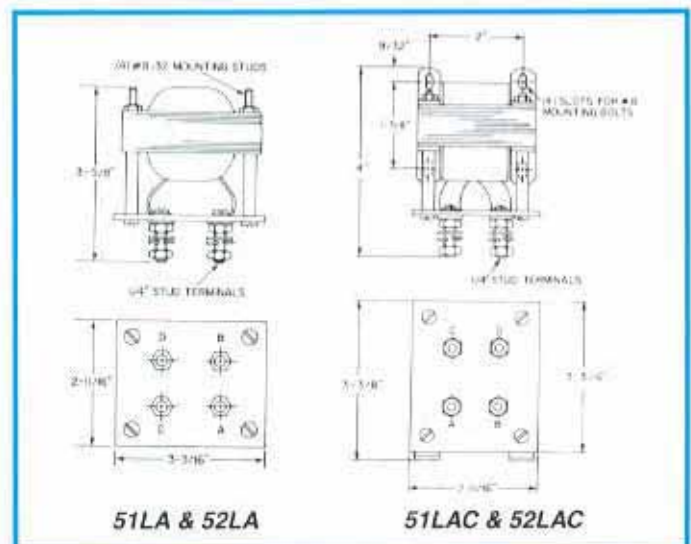

Product Selector Guide

Product Quick Selector

The STACO Variable Transformer Product Quick Selector is a guide to all standard single-phase and three-phase variable transformers in the Staco product line including portable, ganged and motorized models. Units are listed by voltage rating and by increasing values of current and KVA.

With known values of voltage, current and frequency, the STACO Variable Transformer Selector can be used to locate the particular transformer that best fits your requirements. If a

motor driven model is ordered, be sure to prefix the part number with the desired travel time, typically 5, 15, 30 or 60 seconds.

For non-standard operating conditions, refer to the Product Design and Engineering Section of this catalog.

Ratings and configurations not included in the Variable Transformer Selector may be obtained by consulting our STACO representative or by contacting the factory.

	INPUT		OUTPUT				MANUALLY OPERATED	MOTOR DRIVEN		DETAILED TECHNICAL INFO PAGE		
	VOLTS	HERTZ	VOLTS	CONSTANT CURRENT LOAD†		CONSTANT IMPEDANCE LOAD‡		PART NUMBER	AVAILABLE SPEEDS (sec. at 60 Hz*)			
				MAX AMPS	MAX KVA	MAX AMPS					MAX KVA	
SINGLE PHASE	120	50/60 60	0-120	1.75	0.21	2.2	0.26	171	—	—	10	
			0-132	1.75	0.23	—	—	—	—	—	—	
		50/60 60	0-120	2.00	0.24	2.5	0.30	201	—	—	10	
			0-132	2.00	0.26	—	—	—	—	—	—	
		50/60 60	0-120	2.50	0.30	3.2	0.38	221-B	—	—	10	
			0-132 ■	2.50	0.33	—	—	3PN221B	—	—	—	
		50/60 60	0-120	3.00	0.36	3.5	0.42	291	—	—	11	
			0-132	3.00	0.40	—	—	—	—	—	—	
		50/60	0-120	0-140 ■	5.0	0.60	7.0	0.84	501-B, 511	M501-B	5,15,30,60	12
				0-140 ■	5.0	0.70	—	—	3PN501B	—	—	—
		50/60	0-120	0-140 ■	10	1.20	13	1.56	1010B	M1010B	5,15,30,60	14
				0-140 ■	10	1.40	—	—	3PN1010B	—	—	—
	60	0-120	12	1.44	15	1.80	1210B	M1210B	5,15,30,60	17		
			—	—	—	—	3PN1210B	—	—	—		
	0-120	0-140 ■	15	1.80	20	2.40	1510	M1510B	5,15,30,60	18		
			—	—	—	—	3PN1510B	—	—	—		
	0-140 ■	22	3.08	—	—	—	3PN2210B	—	—	20		
			—	—	—	—	—	—	—	—		
	0-120	0-140	25	3.00	30	3.60	2510	M2510	5,15,30,60	20		
			25	3.50	—	—	—	—	—	—		
	0-120	0-140	50	6.00	60	7.20	2510-2•	M2510-2•	5,15,30,60	20		
			50	7.00	—	—	—	—	—	—		
	0-140	50	7.00	—	—	—	5011	M5011	5,15,30,60	22		
			—	—	—	—	—	—	—	—		
	0-120	0-140	60	7.20	—	—	6011	M6011	5,15,30,60	30		
			60	8.40	—	—	—	—	—	—		
	0-120	0-140	75	9.00	90	10.80	2510-3••	M2511-3••	5,15,30,60	20		
			75	10.50	—	—	—	—	—	—		
	0-140	100	14.00	—	—	—	5011-2P	M5011-2P	5,15,30,60	22		
			—	—	—	—	—	—	—	—		
	0-120	0-140	120	14.40	—	—	6011-2P	M6011-2P	5,15,30,60	30		
			120	16.80	—	—	—	—	—	—		
0-140	150	21.00	—	—	—	5011-3P	M5011-3P	5,15,30,60	22			
		—	—	—	—	—	—	—	—			
0-120	0-140	180	21.60	—	—	6011-3P	M6011-3P	5,15,30,60	30			
		180	25.20	—	—	—	—	—	—			
0-140	200	28.00	—	—	—	5011-4P	M5011-4P	15,30,60	23			
		—	—	—	—	—	—	—	—			
0-120	0-140	240	28.80	—	—	6011-4P	M6011-4P	15,30,60	31			
		240	33.60	—	—	—	—	—	—			
0-140	250	35.00	—	—	—	5011-5P	M5011-5P	15,30,60	23			
		—	—	—	—	—	—	—	—			
0-120	0-140	300	36.00	—	—	6011-5P	M6011-5P	15,30,60	31			
		300	42.00	—	—	—	—	—	—			
0-140	300	42.00	—	—	—	5011-6P	M5011-6P	15,30,60	23			
		—	—	—	—	—	—	—	—			
0-140	350	49.00	—	—	—	5011-7P	M5011-7P	30, 60	24			
		—	—	—	—	—	—	—	—			
0-120	0-140	360	43.20	—	—	6011-6P	M6011-6P	15,30,60	31			
		360	50.40	—	—	—	—	—	—			
0-140	400	58.00	—	—	—	5011-8P	M5011-8P	30, 60	24			
		—	—	—	—	—	—	—	—			
0-120	0-140	420	50.40	—	—	6011-7P	M6011-7P	30, 60	32			
		420	58.80	—	—	—	—	—	—			

Product Quick Selector

	INPUT		OUTPUT				MANUALLY OPERATED	MOTOR DRIVEN		DETAILED TECHNICAL INFO PAGE	
	VOLTS	HERTZ	VOLTS	CONSTANT CURRENT LOAD†		CONSTANT IMPEDANCE LOAD‡		PART NUMBER	AVAILABLE SPEEDS (sec. at 60 Hz*)		
				MAX AMPS	MAX KVA	MAX AMPS					MAX KVA
SINGLE PHASE	120	50/60	0-140	450	63.00	—	—	5011-9P	M5011-9P	30, 60	24
			0-120	480	57.60	—	—	6011-8P	M6011-8P	30, 60	32
			0-140	480	67.20	—	—				
			0-120	540	64.80	—	—	6011-9P	M6011-9P	30, 60	32
0-140	540	75.60	—	—							
SINGLE Ø VOLTAGE DOUBLERS	120	50/60	0-280	3.50▲	0.42	—	—	1020B	M1020B	5,15,30,60	14
				9.50▲	1.14	—	—	1520	M1520	5,15,30,60	18
				10▲	1.20	—	—	2520	M2520	5,15,30,60	20
				20▲	2.40	—	—	2520-2*	M2520-2*	5,15,30,60	20
				28▲	3.40	—	—	5021	M5021	5,15,30,60	22
				30▲	3.60	—	—	2520-3	M2520-3	5,15,30,60	20
				35▲	4.20	—	—	6020	M6020	5,15,30,60	30
				56▲	6.80	—	—	5021-2P	M5021-2P	5,15,30,60	22
				70▲	8.40	—	—	6020-2P	M6020-2P	5,15,30,60	30
				84▲	10.20	—	—	5021-3P	M5021-3P	5,15,30,60	23
				105▲	12.60	—	—	6020-3P	M6020-3P	5,15,30,60	31
				112▲	13.50	—	—	5021-4P	M5021-4P	15, 30, 60	23
				140▲	16.80	—	—	6020-4P	M6020-4P	15, 30, 60	31
				168▲	20.40	—	—	5021-6P	M5021-6P	15, 30, 60	24
				175▲	21.00	—	—	6020-5P	M6020-5P	15, 30, 60	31
				196▲	23.50	—	—	5021-7P	M5021-7P	30, 60	24
				210▲	25.20	—	—	6020-6P	M6020-6P	15, 30, 60	32
				224▲	26.90	—	—	5021-8P	M5021-8P	30, 60	24
245▲	29.40	—	—	6020-7P	M6020-7P	30, 60	32				
252▲	30.20	—	—	5021-9P	M5021-9P	30, 60	24				
280▲	33.60	—	—	6020-8P	M6020-8P	30, 60	32				
315▲	37.80	—	—	6020-9P	M6020-9P	30, 60	32				
SINGLE PHASE	240	50/60	0-240	0.80	0.19	1.00	0.24	252	—	—	10
			0-264	0.80	0.21	—	—				
		50/60 60	0-240	1.75	0.42	2.20	0.53	171-2	—	—	10
			0-264	1.75	0.46	—	—				
		50/60 60	0-240	2.00	0.48	2.50	0.60	201-2	—	—	10
			0-264	2.00	0.53	—	—				
		50/60 60	0-240	2.50	0.60	3.20	0.77	221-B-2	—	—	10
			0-264	2.50	0.66	—	—				
		50/60 60	0-240	3.00	0.72	3.50	0.84	291-2	—	—	11
			0-264	3.00	0.79	—	—				
		50/60	0-240	3.50	0.84	5.0	1.20	1020B 3PN1020B	M1020B —	5,15,30,60 —	14
			0-280 ■	3.50	0.98	—	—				
		50/60	0-240	5.00	1.20	7.00	1.68	501-B-2	M501-B-2	5,15,30,60	12
			0-280	5.00	1.40	—	—				
		60	0-240	5.00	1.20	7.00	1.68	1220B 3PN1220B	M1220B —	5,15,30,60 —	17
				5.00	1.40	—	—				
		50/60	0-240	9.50	2.28	12.00	2.88	1520 3PN1520B	M1520 —	5,15,30,60 —	18
			0-280 ■	9.50	2.66	—	—				
50/60	0-240	10	2.40	13	3.12	1010B-2	M1010B-2	5,15,30,60	14		
	0-280	10	2.80	—	—						
50/60	0-240	10	2.40	13	3.12	2520 3PN2520B	M2520 —	5,15,30,60 —	20		
	0-280 ■	10	2.80	—	—						
60	0-240	12	2.88	15	3.60	1210B-2	M1210B-2	5,15,30,60	17		
		15	3.60	20	4.80						
50/60	0-240	15	3.60	20	4.80	1510-2	M1510-2	5,15,30,60	18		
	0-280	15	4.20	—	—						
50/60	0-240	20	4.80	26	6.20	2520-2*	M2520-2*	5,15,30,60	20		
	0-280	20	5.60	—	—						
50/60	0-240	25	6.00	30	7.20	2510-2	M2510-2	5,15,30,60	20		
	0-280	25	7.00	—	—						
50/60	0-240	28	6.70	—	—	5021	M5021	5,15,30,60	22		
	0-280	28	7.80	—	—						

Product Quick Selector

		INPUT		OUTPUT				MANUALLY OPERATED	MOTOR DRIVEN		DETAILED TECHNICAL INFO PAGE		
		VOLTS	HERTZ	VOLTS	CONSTANT CURRENT LOAD†		CONSTANT IMPEDANCE LOAD‡		PART NUMBER	PART NUMBER		AVAILABLE SPEEDS (sec. at 60 Hz*)	
					MAX AMPS	MAX KVA	MAX AMPS						MAX KVA
SINGLE PHASE	240	50/60	0-240	30	7.20	39	9.40	2520-3**	M2520-3**	5,15,30,60	20		
			0-280	30	8.40	—	—	6020	M6020	5,15,30,60	30		
			0-280	50	14.00	—	—	5011-2S	M5011-2S	5,15,30,60	22		
			0-240	56	13.40	—	—	5021-2P	M5021-2P	5,15,30,60	22		
			0-280	56	15.70	—	—	6011-2S	M6011-2S	5,15,30,60	30		
			0-240	60	14.40	—	—	6020-2P	M6020-2P	5,15,30,60	30		
			0-280	60	16.80	—	—	5021-3P	M5021-3P	5,15,30,60	23		
			0-240	70	16.80	—	—	6020-3P	M6020-3P	5,15,30,60	31		
			0-280	70	19.60	—	—	5021-4P	M5021-4P	15, 30, 60	23		
			0-240	84	20.20	—	—	6011-4PS	M6011-4PS	15, 30, 60	31		
			0-280	84	23.50	—	—	6020-4P	M6020-4P	15, 30, 60	31		
			0-240	105	25.20	—	—	5011-6PS	M5011-6PS	15, 30, 60	23		
			0-280	105	29.40	—	—	5021-6P	M5021-6P	15, 30, 60	24		
			0-240	112	26.90	—	—	6020-5P	M6020-5P	15, 30, 60	31		
			0-280	112	31.40	—	—	6011-6PS	M6011-6PS	15, 30, 60	31		
			0-240	120	28.80	—	—	5021-7P	M5021-7P	30, 60	24		
			0-280	120	33.60	—	—	6020-6P	M6020-6P	15, 30, 60	32		
			0-240	140	33.80	—	—	5021-8P	M5021-8P	30, 60	24		
		0-280	140	39.20	—	—	6020-7P	M6020-7P	30, 60	32			
		0-280	150	42.00	—	—	—	M5011-10PS	30, 60	24			
		0-240	168	40.30	—	—	5021-9P	M5021-9P	30, 60	24			
		0-280	168	47.00	—	—	6020-8P	M6020-8P	30, 60	32			
		0-240	175	42.00	—	—	6020-9P	M6020-9P	30, 60	32			
		0-280	175	49.00	—	—	—	M6011-12PS	30, 60	33			
		0-240	180	43.20	—	—	6011-8PS	M6011-8PS	30, 60	32			
		0-280	180	50.40	—	—	—	M6011-14PS	60	33			
		0-240	196	47.00	—	—	5021-8P	M5021-8P	30, 60	24			
		0-280	196	54.90	—	—	—	M6011-16PS	60	33			
		0-240	210	50.40	—	—	6020-8P	M6020-8P	30, 60	32			
		0-280	210	58.80	—	—	—	M6011-18PS	60	33			
		0-240	224	53.80	—	—	5021-8P	M5021-8P	30, 60	24			
		0-280	224	62.70	—	—	—	—	—	—			
		0-240	240	57.60	—	—	6011-8PS	M6011-8PS	30, 60	32			
0-280	240	67.20	—	—	6020-7P	M6020-7P	30, 60	32					
0-240	245	58.80	—	—	—	—	—	—					
0-280	245	68.60	—	—	—	—	—	—					
0-280	250	70.00	—	—	—	—	—	—					
0-240	252	60.50	—	—	5021-9P	M5021-9P	30, 60	24					
0-280	252	70.60	—	—	6020-8P	M6020-8P	30, 60	32					
0-240	280	67.20	—	—	6020-8P	M6020-8P	30, 60	32					
0-280	280	78.40	—	—	—	—	—	—					
0-240	300	72.00	—	—	—	—	—	—					
0-280	300	84.00	—	—	—	—	—	—					
0-240	315	75.60	—	—	6020-9P	M6020-9P	30, 60	32					
0-280	315	88.20	—	—	—	—	—	—					
0-240	360	86.40	—	—	—	—	—	—					
0-280	360	100.80	—	—	—	—	—	—					
0-240	420	100.80	—	—	—	—	—	—					
0-280	420	117.60	—	—	—	—	—	—					
0-240	480	115.20	—	—	—	—	—	—					
0-280	480	134.40	—	—	—	—	—	—					
0-240	540	129.60	—	—	—	—	—	—					
0-280	540	151.20	—	—	—	—	—	—					
1 PHASE V. DOUBLERS	240	50/60	0-560	3.50 ▲	0.84	—	—	1020B-2	M1020B-2	5,15,30,60	14		
				9.50 ▲	2.28	—	—	1520-2	M1520-2	5,15,30,60	18		
				10 ▲	2.40	—	—	2520-2	M2520-2	5,15,30,60	20		
				28 ▲	6.80	—	—	5021-2S	M5021-2S	5,15,30,60	22		
				35 ▲	8.40	—	—	6020-2S	M6020-2S	5,15,30,60	30		

Product Quick Selector

	INPUT		OUTPUT				MANUALLY OPERATED	MOTOR DRIVEN		DETAILED TECHNICAL INFO PAGE	
	VOLTS	HERTZ	VOLTS	CONSTANT CURRENT LOAD†		CONSTANT IMPEDANCE LOAD‡		PART NUMBER	AVAILABLE SPEEDS (sec. at 60 Hz*)		
				MAX AMPS	MAX KVA	MAX AMPS					MAX KVA
SINGLE PHASE VOLTAGE DOUBLERS	240	50/60	0-560	56 ▲	13.50	—	—	5021-4PS	M5021-4PS	15, 30, 60	23
				70 ▲	16.80	—	—	6020-4PS	M6020-4PS	15, 30, 60	31
				84 ▲	20.40	—	—	5021-6PS	M5021-6PS	15, 30, 60	24
				105▲	25.20	—	—	6020-6PS	M6020-6PS	15, 30, 60	32
				112 ▲	26.90	—	—	5021-8PS	M5021-8PS	30, 60	24
				140 ▲	33.60	—	—	6020-8PS	M6020-8PS	30, 60	32
				168 ▲	40.30	—	—	—	M5021-12PS	30, 60	25
				175 ▲	42.00	—	—	—	M6020-10PS	30, 60	33
				196 ▲	47.10	—	—	—	M5021-14PS	60	25
				210 ▲	50.40	—	—	—	M6020-12PS	30, 60	33
				224 ▲	53.80	—	—	—	M5021-16PS	60	25
				245 ▲	58.80	—	—	—	M6020-14PS	60	33
				252 ▲	60.50	—	—	—	M5021-18PS	60	25
				280 ▲	67.20	—	—	—	M6020-16PS	60	33
315 ▲	75.60	—	—	—	M6020-18PS	60	33				
SINGLE PHASE	480	50/60	0-480	0.80	0.38	1.00	0.48	252-2	—	—	10
				0.80	0.42	—	—				
			50/60	0-480	3.50	1.68	5.00	2.40	1020B-2	M1020B-2	5, 15, 30, 60
		3.50			1.96	—	—				
		60	0-480	5.00	2.40	7.00	3.36	1220B-2	M1220B-2	5, 15, 30, 60	17
				9.50	4.56	12	5.76				
		50/60	0-480	9.50	5.32	—	—	1520-2	M1520-2	5, 15, 30, 60	18
				10	4.80	13	6.24				
			0-480	10	5.60	—	—	2520-2	M2520-2	5, 15, 30, 60	20
				28	13.50	—	—				
			0-480	28	15.70	—	—	5021-2S	M5021-2S	5, 15, 30, 60	22
				35	16.80	—	—				
			0-480	35	19.60	—	—	6020-2S	M6020-2S	5, 15, 30, 60	30
				56	26.90	—	—				
			0-480	56	31.40	—	—	5021-4PS	M5021-4PS	15, 30, 60	23
				70	33.60	—	—				
			0-480	70	39.20	—	—	6020-4PS	M6020-4PS	15, 30, 60	31
				84	40.30	—	—				
			0-480	84	47.00	—	—	5021-6PS	M5021-6PS	15, 30, 60	24
				105	50.40	—	—				
			0-480	105	58.80	—	—	6020-6PS	M6020-6PS	15, 30, 60	32
				112	53.80	—	—				
			0-480	112	62.70	—	—	5021-8PS	M5021-8PS	30, 60	24
				140	67.20	—	—				
			0-480	140	78.40	—	—	6020-8PS	M6020-8PS	30, 60	32
				168	80.60	—	—				
			0-480	168	94.10	—	—	—	M5021-12PS	30, 60	25
				175	84.00	—	—				
			0-480	175	98.00	—	—	—	M6020-10PS	30, 60	33
				196	94.10	—	—				
0-480	196		109.80	—	—	—	M5021-14PS	60	25		
	210		100.80	—	—						
0-480	210		117.60	—	—	—	M6020-12PS	30, 60	33		
	224		107.50	—	—						
0-480	224	125.50	—	—	—	M5021-16PS	60	25			
	245	117.60	—	—							
0-480	245	137.20	—	—	—	M6020-14PS	60	33			
	252	121.00	—	—							
0-480	252	141.00	—	—	—	M5021-18PS	60	25			
	280	134.40	—	—							
0-480	280	156.80	—	—	—	M6020-16PS	60	33			
	315	151.20	—	—							
0-480	315	176.40	—	—	—	M6020-18PS	60	33			

Product Quick Selector

	INPUT		OUTPUT				MANUALLY OPERATED	MOTOR DRIVEN		DETAILED TECHNICAL INFO PAGE		
	VOLTS	HERTZ	VOLTS	CONSTANT CURRENT LOAD†		CONSTANT IMPEDANCE LOAD‡		PART NUMBER	PART NUMBER		AVAILABLE SPEEDS (sec. at 60 Hz*)	
				MAX AMPS	MAX KVA	MAX AMPS						MAX KVA
THREE PHASE OPEN DELTA VOLTAGE DOUBLERS	120	50/60	0-280	3.50▲	0.73	—	—	1020B-2	M1020B-2	5,15,30,60	14	
				9.50▲	1.98	—	—	1520-2	M1520-2	5,15,30,60	18	
				10▲	2.10	—	—	2520-2	M2520-2	5,15,30,60	20	
				28▲	5.80	—	—	5021-2D	M5021-2D	5,15,30,60	22	
				35▲	7.30	—	—	6020-2D	M6020-2D	5,15,30,60	30	
				56▲	11.80	—	—	5021-4D	M5021-4D	15, 30, 60	23	
				70▲	14.50	—	—	6020-4D	M6020-4D	15, 30, 60	31	
				84▲	17.60	—	—	5021-6D	M5021-6D	15, 30, 60	24	
				105▲	21.80	—	—	6020-6D	M6020-6D	15, 30, 60	32	
				112▲	23.30	—	—	5021-8D	M5021-8D	30, 60	24	
				140▲	29.10	—	—	6020-8D	M6020-8D	30, 60	32	
				175▲	36.30	—	—	—	M6020-10D	30, 60	32	
				196▲	40.80	—	—	—	M5021-14D	60	25	
				210▲	43.60	—	—	—	M6020-12D	30, 60	33	
				224▲	46.60	—	—	—	M5021-16D	60	25	
				245▲	50.90	—	—	—	M6020-14D	60	33	
				252▲	52.50	—	—	—	M5021-18D	60	25	
280▲	58.10	—	—	—	M6020-16D	60	33					
315▲	94.50	—	—	—	M6020-18D	60	33					
THREE PHASE OPEN DELTA	240	50/60	0-240	0.80	0.33	1.00	0.42	252-2	—	—	10	
			0-264	0.80	0.37	—	—	—	—	—	—	
		60	0-240	3.50	1.45	5.00	2.08	1020B-2	M1020B-2	5,15,30,60	14	
			0-280	3.50	1.70	—	—	—	—	—	—	
		50/60	0-240	5.00	2.08	7.00	2.91	1220B-2	M1220B-2	5,15,30,60	17	
			0-240	9.50	3.95	12	5.00	1520-2	M1520-2	5,15,30,60	18	
			0-280	9.50	4.61	—	—	—	—	—	—	
			0-240	10	4.20	13	5.40	2520-2	M2520-2	5,15,30,60	20	
			0-280	10	4.85	—	—	—	—	—	—	
			0-240	28	11.60	—	—	5021-2D	M5021-2D	5,15,30,60	22	
			0-280	28	13.60	—	—	—	—	—	—	
			0-240	35	14.50	—	—	6020-2D	M6020-2D	5,15,30,60	30	
			0-280	35	16.90	—	—	—	—	—	—	
			0-240	56	23.30	—	—	5021-4D	M5021-4D	15, 30, 60	23	
			0-280	56	27.20	—	—	—	—	—	—	
			0-240	70	29.10	—	—	6020-4D	M6020-4D	15, 30, 60	31	
			0-280	70	33.90	—	—	—	—	—	—	
			0-240	84	34.90	—	—	5021-6D	M5021-6D	15, 30, 60	24	
			0-280	84	40.70	—	—	—	—	—	—	
			0-240	105	43.60	—	—	6020-6D	M6020-6D	15, 30, 60	32	
			0-280	105	50.90	—	—	—	—	—	—	
			0-240	112	46.60	—	—	5021-8D	M5021-8D	30, 60	24	
			0-280	112	54.30	—	—	—	—	—	—	
			0-240	140	58.10	—	—	6020-8D	M6020-8D	30, 60	32	
		0-280	140	67.80	—	—	—	—	—	—		
		0-240	175	72.70	—	—	—	M6020-10D	30, 60	32		
		0-280	175	84.80	—	—	—	—	—	—		
		0-240	196	81.50	—	—	—	M5021-14D	60	25		
0-280	196	95.10	—	—	—	—	—	—				
0-240	210	87.20	—	—	—	M6020-12D	30, 60	33				
0-280	210	101.70	—	—	—	—	—	—				
0-240	224	93.10	—	—	—	M5021-16D	—	25				
0-280	224	108.60	—	—	—	—	—	—				
0-240	245	101.70	—	—	—	M6020-14D	60	33				
0-280	245	118.70	—	—	—	—	—	—				
0-240	252	104.50	—	—	—	M5021-18D	60	25				
0-280	252	122.20	—	—	—	—	—	—				
0-240	280	116.30	—	—	—	M6020-16D	60	33				
0-280	280	135.60	—	—	—	—	—	—				
0-240	315	130.80	—	—	—	M6020-18D	60	33				
0-280	315	152.60	—	—	—	—	—	—				

Product Quick Selector

	INPUT		OUTPUT				MANUALLY OPERATED	MOTOR DRIVEN		DETAILED TECHNICAL INFO PAGE				
	VOLTS	HERTZ	VOLTS	CONSTANT CURRENT LOAD†		CONSTANT IMPEDANCE LOAD‡		PART NUMBER	AVAILABLE SPEEDS (sec. at 60 Hz*)					
				MAX AMPS	MAX KVA	MAX AMPS					MAX KVA			
THREE PHASE WYE	240	60	0-240	1.75	0.73	2.20	0.92	171-3	—	—	10			
			0-240	2.00	0.83	2.50	1.04	201-3	—	—	10			
			0-240	2.50	1.04	3.20	1.33	221-B-3	—	—	10			
			0-240	3.00	1.25	3.50	1.45	291-3	—	—	11			
			50/60	0-240	5.00	2.08	7.00	2.91	501-B-3	M501-B-3	5, 15, 30, 60	12		
			60	0-280	5.00	2.43	—	—						
			50/60	0-240	10	4.16	13	5.40	1010B-3	M1010B-3	5, 15, 30, 60	14		
			60	0-280	10	4.85	—	—						
			60	0-240	12	4.96	15	6.24	1210B-3	M1210B-3	5, 15, 30, 60	17		
			50/60	0-240	15	6.22	20	8.30	1510-3	M1510-3	5, 15, 30, 60	18		
			60	0-280	15	7.26	—	—						
			50/60	0-240	25	10.40	30	12.50	2510-3	M2510-3	5, 15, 30, 60	20		
			60	0-280	25	12.10	—	—						
						0-280	50	24.20	—	—	5011-3Y	M5011-3Y	5, 15, 30, 60	22
						0-240	60	24.90	—	—	6011-3Y	M6011-3Y	5, 15, 30, 60	30
						0-280	60	29.10	—	—				
						0-280	100	48.50	—	—	5011-6Y	M5011-6Y	15, 30, 60	23
						0-240	120	49.80	—	—	6011-6Y	M6011-6Y	15, 30, 60	31
						0-280	120	58.10	—	—				
						0-280	150	72.50	—	—	5011-9Y	M5011-9Y	30, 60	24
						0-240	180	74.70	—	—	6011-9Y	M6011-9Y	30, 60	32
						0-280	180	87.20	—	—				
						0-280	200	96.70	—	—	—	M5011-12Y	30, 60	25
						0-240	240	99.60	—	—	—	M6011-12Y	30, 60	33
						0-280	240	116.30	—	—				
						0-280	250	121.00	—	—	—	M5011-15Y	60	26
						0-240	300	124.60	—	—	—	M6011-15Y	60	34
						0-280	300	145.30	—	—				
						0-240	360	149.50	—	—	—	M6011-18Y	60	34
						0-280	360	174.40	—	—				
						0-280	400	193.70	—	—	—	M5011-24Y	60	26
						0-240	420	174.40	—	—	—	M6011-21Y	60	34
			0-280	420	203.40	—	—							
			0-280	450	218.40	—	—	—	M5011-27Y	60	26			
			0-240	480	199.30	—	—	—	M6011-24Y	60	34			
			0-280	480	232.50	—	—							
			0-240	540	224.20	—	—	—	M6011-27Y	60	34			
			0-280	540	261.60	—	—							
THREE PHASE WYE VOLTAGE DOUBLERS	240	60	0-560	3.50▲	1.46	—	—	1020B-3	M1020B-3	5, 15, 30, 60	14			
				9.50▲	3.96	—	—	1520-3	M1520-3	5, 15, 30, 60	18			
				10▲	4.20	—	—	2520-3	M2520-3	5, 15, 30, 60	20			
				28▲	11.80	—	—	5021-3Y	M5021-3Y	5, 15, 30, 60	23			
				35▲	14.50	—	—	6020-3Y	M6020-3Y	5, 15, 30, 60	31			
				56▲	23.50	—	—	5021-6Y	M5021-6Y	15, 30, 60	24			
				70▲	29.10	—	—	6020-6Y	M6020-6Y	15, 30, 60	32			
				84▲	35.00	—	—	5021-9Y	M5021-9Y	30, 60	24			
				105▲	43.60	—	—	6020-9Y	M6020-9Y	30, 60	32			
				112▲	46.60	—	—	—	M5021-12Y	30, 60	25			
				140▲	58.10	—	—	—	M6020-12Y	30, 60	34			
				168▲	70.00	—	—	—	M5021-18Y	60	26			
				175▲	72.70	—	—	—	M6020-15Y	60	34			
				196▲	82.00	—	—	—	M5021-21Y	60	26			
				210▲	87.20	—	—	—	M6020-18Y	60	34			
				224▲	93.00	—	—	—	M5021-24Y	60	26			
				245▲	101.70	—	—	—	M6020-21Y	60	34			
				252▲	105.00	—	—	—	M5021-27Y	60	26			
				280▲	116.30	—	—	—	M6020-24Y	60	34			
				315▲	130.80	—	—	—	M6020-27Y	60	34			

Product Quick Selector

	INPUT		OUTPUT				MANUALLY OPERATED	MOTOR DRIVEN		DETAILED TECHNICAL INFO PAGE	
	VOLTS	HERTZ	VOLTS	CONSTANT CURRENT LOAD†		CONSTANT IMPEDANCE LOAD‡		PART NUMBER	AVAILABLE SPEEDS (sec. at 60 Hz*)		
				MAX AMPS	MAX kVA	MAX AMPS					MAX kVA
THREE PHASE WYE	50/60	60	0-480	0.80	0.67	1.00	0.83	252-3	—	—	10
			0-528	0.80	0.73	—	—				
	50/60	60	0-480	3.50	2.91	5.00	4.16	1020B-3	M1020B-3	5,15,30,60	14
			0-560	3.50	3.40	—	—				
	60		0-480	5.00	4.16	7.00	5.82	1220B-3	M1220B-3	5,15,30,60	17
	50/60	60	0-480	9.50	7.90	12	10	1520-3	M1520-3	5,15,30,60	18
			0-560	9.50	9.21	—	—				
	50/60	60	0-480	10	8.30	13	10.81	2520-3	M2520-3	5,15,30,60	20
			0-560	10	9.70	—	—				
	50/60	60	0-480	28	23.30	—	—	5021-3Y	M5021-3Y	5,15,30,60	23
			0-560	28	27.20	—	—				
	50/60	60	0-480	35	29.10	—	—	6020-3Y	M6020-3Y	5,15,30,60	31
			0-560	35	33.90	—	—				
	50/60	60	0-480	56	46.60	—	—	5021-6Y	M5021-6Y	15, 30, 60	24
			0-560	56	54.30	—	—				
	50/60	60	0-480	70	58.10	—	—	6020-6Y	M6020-6Y	15, 30, 60	32
			0-560	70	67.80	—	—				
	50/60	60	0-480	84	69.80	—	—	5021-8Y	M5021-8Y	30, 60	24
			0-560	84	81.50	—	—				
	50/60	60	0-480	105	87.20	—	—	6020-9Y	M6020-9Y	30, 60	32
		0-560	105	101.70	—	—					
480	50/60	60	0-480	112	93.10	—	—	—	M5021-12Y	30, 60	25
			0-560	112	108.60	—	—				
	50/60	60	0-480	140	116.30	—	—	—	M6020-12Y	30, 60	34
			0-560	140	135.60	—	—				
	50/60	60	0-480	168	139.50	—	—	—	M5021-18Y	60	26
			0-560	168	163.30	—	—				
	50/60	60	0-480	175	145.30	—	—	—	M6020-15Y	60	34
			0-560	175	169.50	—	—				
	50/60	60	0-480	196	163.0	—	—	—	M5021-21Y	60	26
			0-560	196	189.5	—	—				
	50/60	60	0-480	210	174.60	—	—	—	M6020-18Y	60	34
			0-560	210	203.40	—	—				
	50/60	60	0-480	224	186.50	—	—	—	M5021-24Y	60	26
			0-560	224	217.80	—	—				
	50/60	60	0-480	245	203.40	—	—	—	M6020-21Y	60	34
			0-560	245	237.40	—	—				
	50/60	60	0-480	252	209.50	—	—	—	M5021-27Y	60	26
			0-560	252	244.00	—	—				
	50/60	60	0-480	280	232.50	—	—	—	M6020-24Y	60	34
			0-560	280	271.30	—	—				
	50/60	60	0-480	315	261.60	—	—	—	M6020-27Y	60	34
			0-560	315	305.20	—	—				

Models with 575V input and 0-575V output are available with Series 6020 variable transformers with a Y, S, or PS suffix. See pages 30, 31, 32, 33 & 34.

† **Constant Current Load** — the normal rated output amperes may be drawn at any position of the brush except in voltage doubler connections.

‡ **Constant Impedance Load** — an increased current may be drawn at the maximum voltage output (Limited to line voltage) provided the current reduces proportionally as output voltage is lowered.

▲ Voltage Doubler (half rates voltage input). Normal rated amperes may be drawn from 0 to 125% of the input voltage. At outputs above this, the load current must be reduced according to the derating guide. Figure B, page 6.

■ Cord and plug models wired this way at the factory

• One 52LAC paralleling choke is required

•• Three 52LAC paralleling chokes are required.

* Speeds are approximately 20% slower at 50Hz.

Your Tailored Power Solutions Provider™

Variable Transformers

Voltage Regulators

Power Conditioners

UPS Products

US Toll Free: 866-261-1191
Phone: 937-253-1191
E-mail: sales@stacoenergy.com
www.stacoenergy.com



**STACO
ENERGY®
PRODUCTS CO.**



Стандарт Электрон Связь

Мы молодая и активно развивающаяся компания в области поставок электронных компонентов. Мы поставляем электронные компоненты отечественного и импортного производства напрямую от производителей и с крупнейших складов мира.

Благодаря сотрудничеству с мировыми поставщиками мы осуществляем комплексные и плановые поставки широчайшего спектра электронных компонентов.

Собственная эффективная логистика и склад в обеспечивает надежную поставку продукции в точно указанные сроки по всей России.

Мы осуществляем техническую поддержку нашим клиентам и предпродажную проверку качества продукции. На все поставляемые продукты мы предоставляем гарантию .

Осуществляем поставки продукции под контролем ВП МО РФ на предприятия военно-промышленного комплекса России , а также работаем в рамках 275 ФЗ с открытием отдельных счетов в уполномоченном банке. Система менеджмента качества компании соответствует требованиям ГОСТ ISO 9001.

Минимальные сроки поставки, гибкие цены, неограниченный ассортимент и индивидуальный подход к клиентам являются основой для выстраивания долгосрочного и эффективного сотрудничества с предприятиями радиоэлектронной промышленности, предприятиями ВПК и научно-исследовательскими институтами России.

С нами вы становитесь еще успешнее!

Наши контакты:

Телефон: +7 812 627 14 35

Электронная почта: sales@st-electron.ru

Адрес: 198099, Санкт-Петербург,
Промышленная ул, дом № 19, литера Н,
помещение 100-Н Офис 331