

# CQFP to CLGA Adapter Socket

## Table of Contents

Introduction . . . . .	1
CQ to LG Adapter Socket . . . . .	1
CQ to LG Adapter Socket Assembly Procedure . . . . .	3
CQ352 to LG1272 Adapter Socket Outline Drawing . . . . .	6
Reflow Profile . . . . .	7
CQ to LG Adapter Pin Mapping List . . . . .	8
Prototyped Product, Adapter, and PCB Design Matrix . . . . .	8
List of Changes . . . . .	8
Support . . . . .	9

## Introduction

RTAX-S/L is next generation, designed-for-space, metal-to-metal antifuse field programmable gate array (FPGA) family by Microsemi. RTAX-S/L is a derivative of the Axcelerator<sup>®</sup> family with up to two million-system gates. RTAX-S/L FPGAs provide the designer with nearly 500K ASIC gates, with error detection and correction (EDAC) protected static RAM. Microsemi offers RTAX-S/L devices in two package styles: the ceramic column grid array (CCGA or CG) and ceramic quad flat pack (CQFP or CQ).

Microsemi has developed prototyping methods for RTAX-S/L devices in CG/CQ packages, using the ceramic land grid array (CLGA) package as a prototyping vehicle with the CQ to LG and CG to LG adapter sockets. This document describes the procedure for assembling the CQ to LG adapter socket.

## CQ to LG Adapter Socket

The CQ to LG adapter socket has an LG configuration on the top and a CQ configuration on the bottom. The adapter socket enables customers to use an LG package during prototyping, and then switch to an equivalent CQFP package for production. There is one CQ to LG adapter socket available. The top and bottom ordering part numbers are listed in [Table 1](#).

**Table 1 • Adapter Socket Part Number**

Adapter Socket	Ordering Part Number	Prototyped and Prototype Device
CQ352 to LG1272	SK-RT4K-KITTOP and SK-RT4K-CQ352-KITBTM	For prototyping RTAX4000S/SL-CQ352 using RTAX4000S/SL-LG1272 package

Figure 1 shows the complete CQ352 to LG1272 assembly kit. SK-RT4K-KITTOP contains an interposer (3), a socket lid (4), and eight screws (5). SK-RT4K-CQ352-KITBTM contains a ceramic adapter (1), socket housing (2), and eight screws (5).

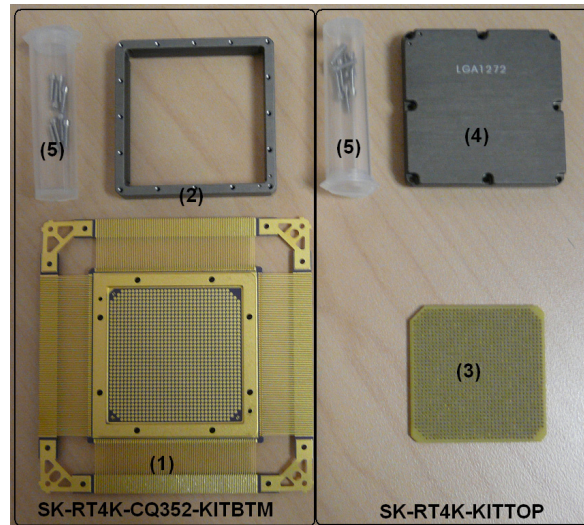

Figure 1 • Parts of CQ352 to LG1272 Adapter Socket: (1) Ceramic Adapter, (2) Socket Housing, (3) Socket Interposer, (4) Socket Lid, (5) Fixing Screws

Figure 2 shows the top view, bottom view, and orientation view for the RTAX4000S/SL CQ352 to LG1272 adapter.

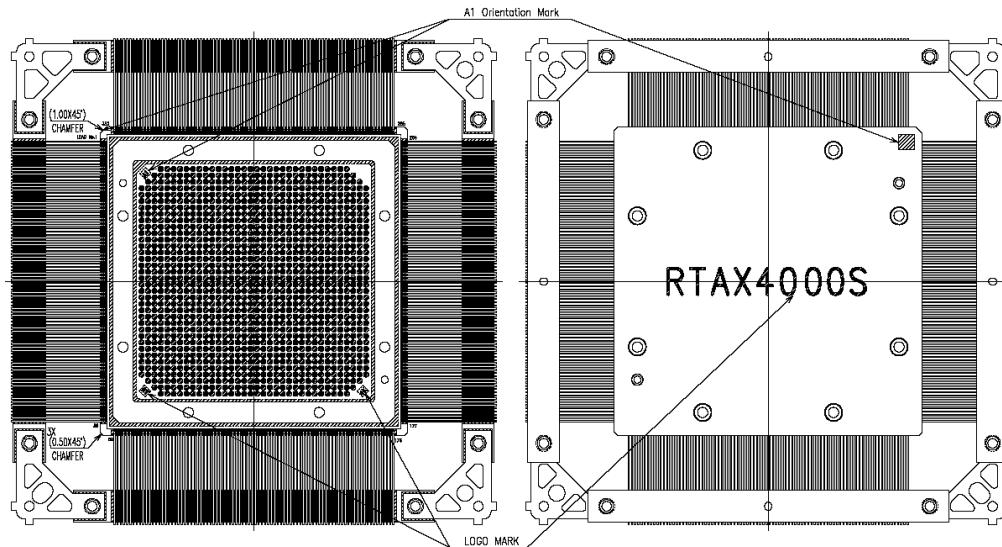

Figure 2 • RTAX4000S/SL CQ352 to LG1272 Ceramic Adapter: Top View, Bottom View, and Orientation Drawing

## CQ to LG Adapter Socket Assembly Procedure

### Step 1

Trim and form the CQ ceramic adapter.

**Note:** Do not reflow the adapter to the circuit board until the housing has been attached, as detailed in Step 2 below.

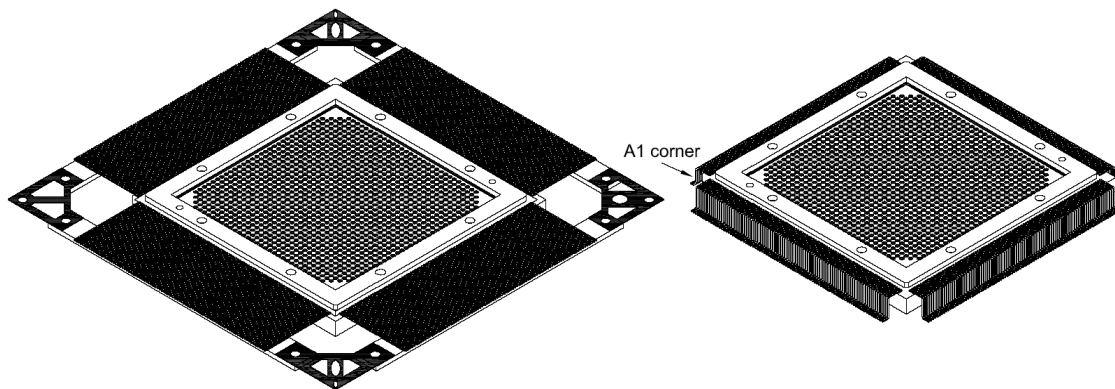

**Figure 3 • CQ352 to LG1272 Adapter Trim and Form**

### Step 2

Assemble socket housing to adapter. A torque limit screw driver is not required (Figure 4).

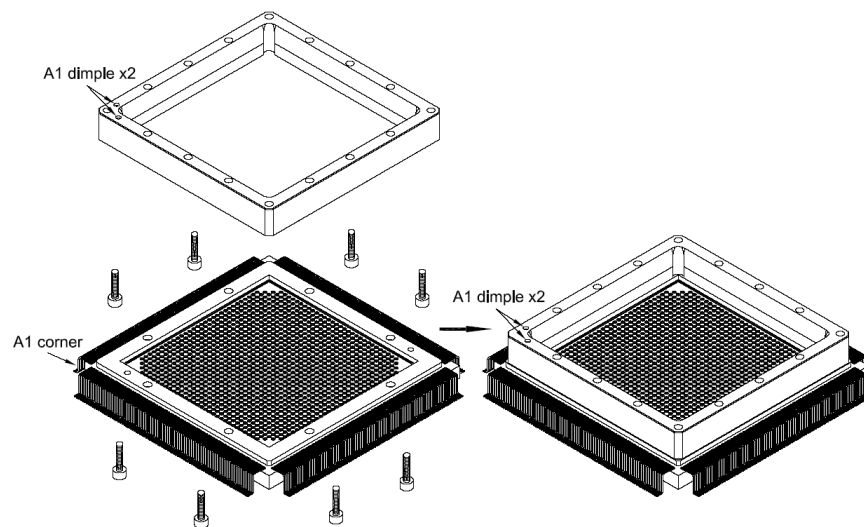

**Figure 4 • Assemble Socket Housing to CQ352 to LG1272 Adapter**

**Note:** The housing, eight screws, and ceramic adapter form the –KITBTM assembly.

### Step 3

Reflow the adapter to the printed circuit board (PCB) as shown in (Figure 5).

**Note:** Since reflow profiles heavily depend upon the size of the board and its components, perform reflow process optimization for better results.

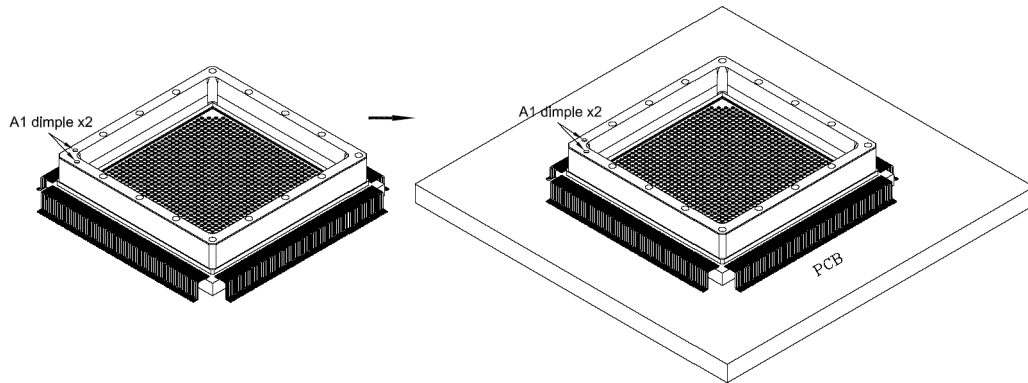

**Figure 5 • Reflow Adapter (with socket housing mounted) to PCB**

### Step 4

Place the socket interposer into the adapter (Figure 6).

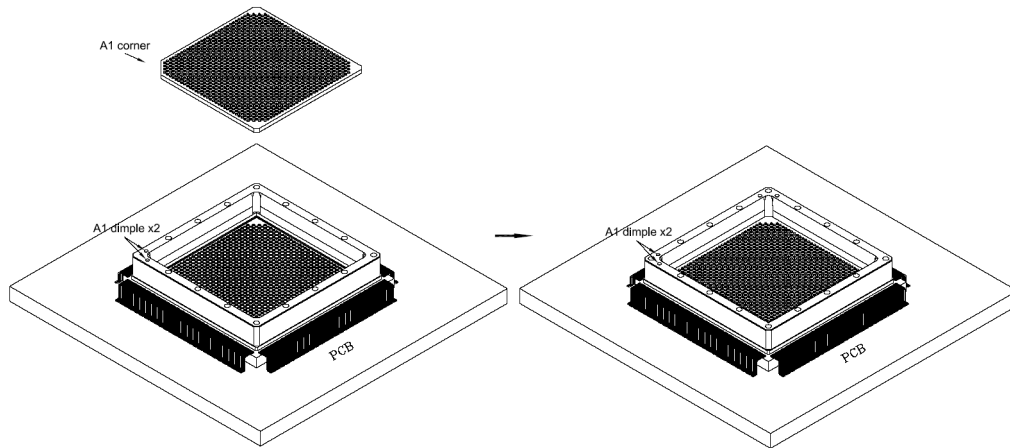

**Figure 6 • Place the Socket Interposer into Adapter Assembly**

## Step 5

Place the LG1272 package into the adapter (Figure 7).

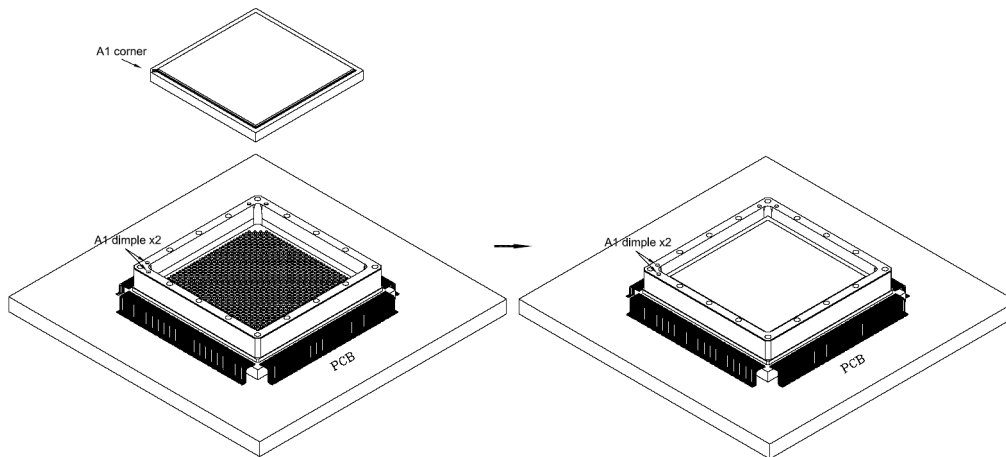

**Figure 7 • Place LG1272 Package into Adapter Assembly**

## Step 6

Place and tighten the socket lid to the socket housing with the remaining eight screws (Figure 8). A torque limit screw driver is not required.

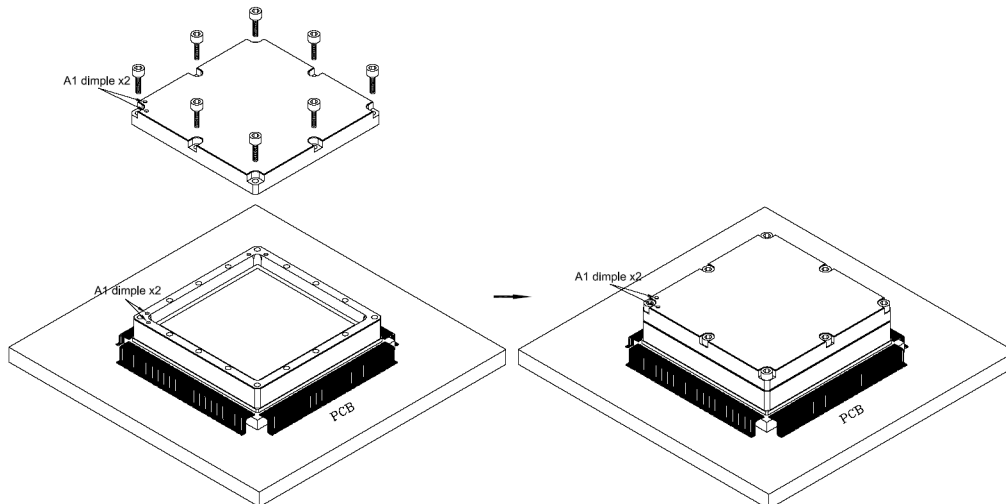

**Figure 8 • Place and Tighten Socket Lid Using Eight Screws and Optional Alignment Pins**

## CQ352 to LG1272 Adapter Socket Outline Drawing

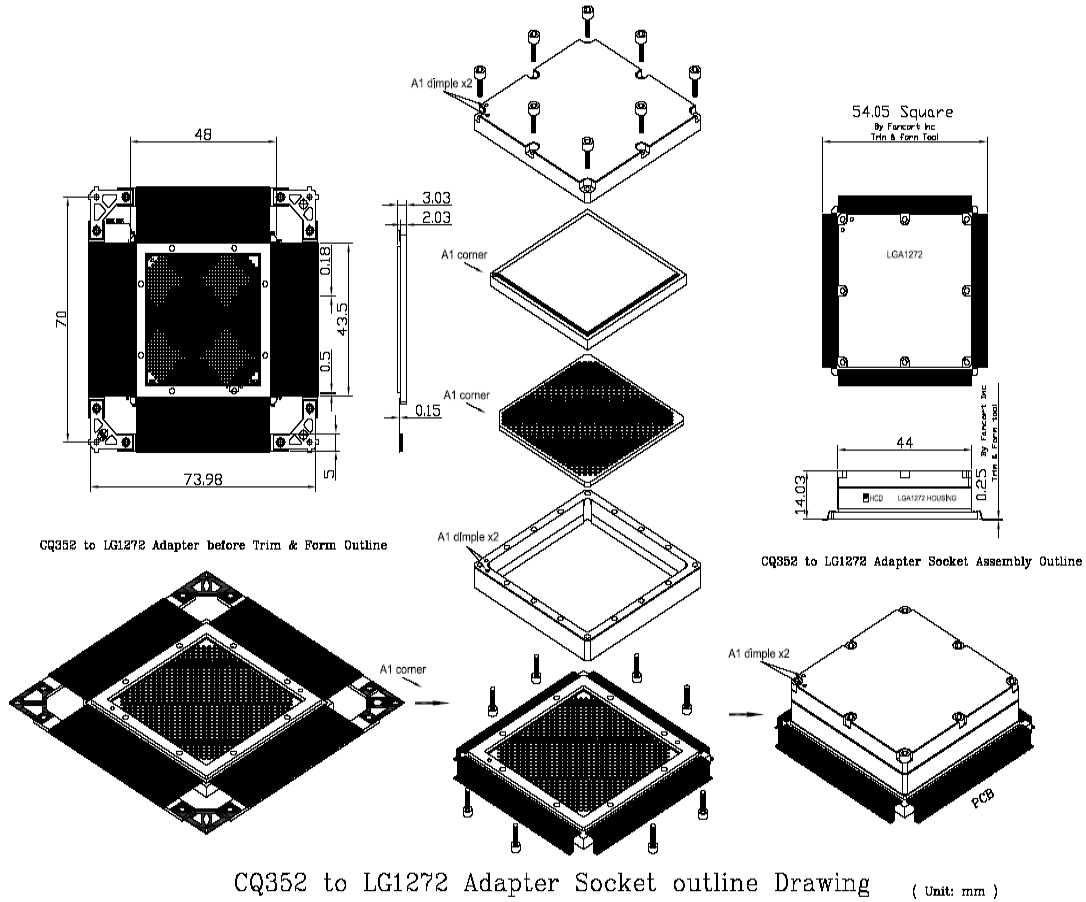
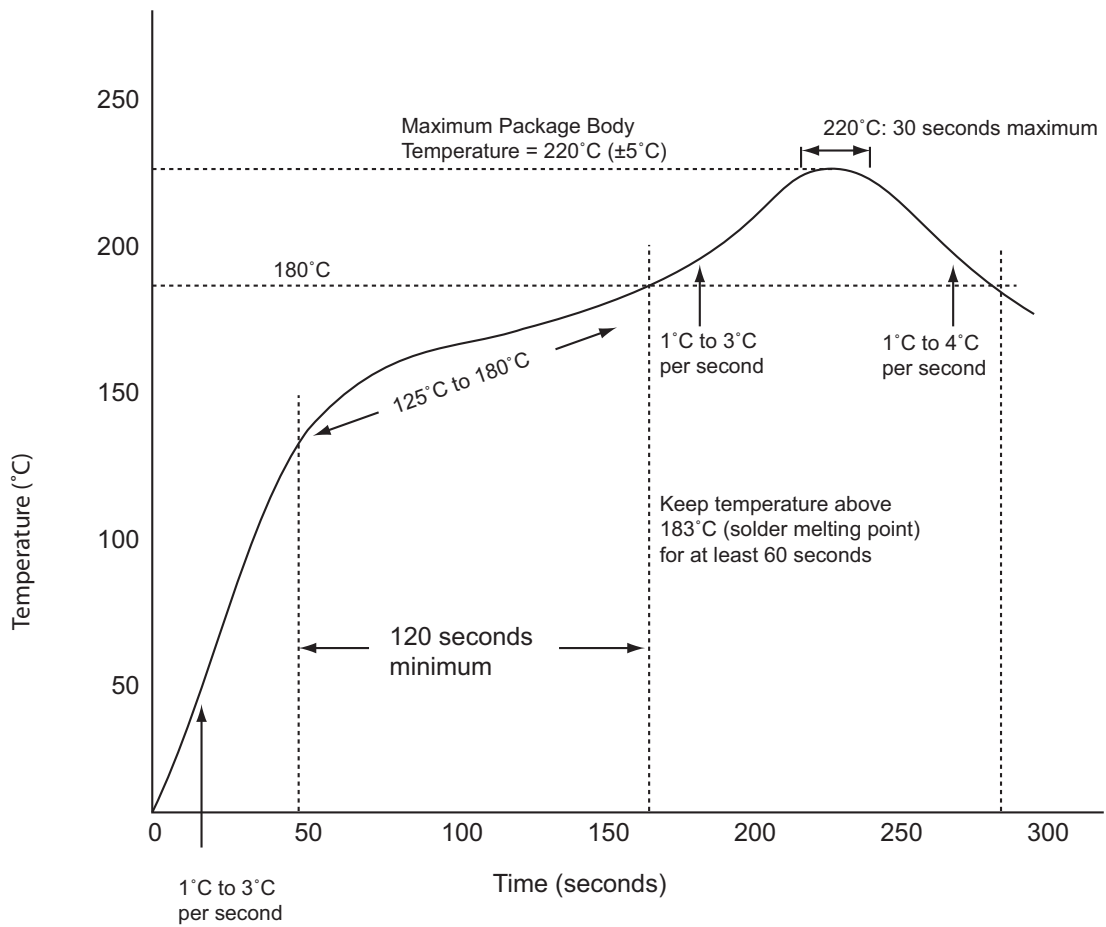

Figure 9 • CQ352 to LG1272 Adapter Socket Outline Drawing (unit: mm)

# Reflow Profile

Since reflow profile depends upon the size of the board and other components, end users should perform additional fine tuning from the general profile, as shown in [Figure 10](#).



**Figure 10 • Sample Temperature Profile for I/R or Convection Reflow**

**Note:** This temperature profile guideline is for reference only.

## CQ to LG Adapter Pin Mapping List

The CQFP to FBGA adapter is routed from the FBGA package to match the existing die pad available to the CQFP device that is being prototyped. Contact Microsemi technical support for a detailed mapping list.

**Table 2 • CQFP to FBGA Adapter Pin Mapping List**

Adapter Socket	Ordering Part Number	Prototyped and Prototype Device	Adapter Pin Mapping List Document Number
CQ352 to LG1272	SK-RT4K-KITTOP and SK-RT4K-CQ352-KITBTM	For prototyping RTAX4000S/SL-CQ352 using RTAX4000S/SL-LG1272 package	1-22-11051

## Prototyped Product, Adapter, and PCB Design Matrix

Designing the PCB for a specific product requires an understanding of which adapter socket works. Each adapter socket is routed differently based on the corresponding Axcelerator device (or its radiation-tolerant equivalent derivative that is being prototyped) and the commercial Axcelerator FG package used for prototyping. Table 3 shows the combinations that works.

**Table 3 • Prototyping Design Matrix**

Prototyped Product	Adapter Part Number	Prototype Vehicle	PCB Design
RTAX4000S/SL-CQ352	SK-RT4K-KITTOP and SK-RT4K-CQ352-KITBTM	RTAX4000S/SL-LG1272	RTAX4000S/SL-CQ352

## List of Changes

The following table lists critical changes that were made in the current version of the document.

Revision	Changes	Page
Revision 1 (February 2013)	Updated Figure Title for Figure 1 (SAR 41790).	2
	Updated "Support" section.	9



## Support

Visit Technical Support online at [www.microsemi.com/soc/kb/search.aspx](http://www.microsemi.com/soc/kb/search.aspx).

### Technical Support

For Technical Support, email at [soc\\_tech@microsemi.com](mailto:soc_tech@microsemi.com).

From North America, call 800.262.1060.

From the rest of the world, call 650.318.4460.

### ITAR Technical Support

For technical support on RH and RT FPGAs that are regulated by International Traffic in Arms Regulations (ITAR), contact via web (Select Yes in the ITAR drop-down list), phone, or email at [www.microsemi.com/soc/mycases](http://www.microsemi.com/soc/mycases).

For ITAR Technical Support, email at [soc\\_tech\\_itar@microsemi.com](mailto:soc_tech_itar@microsemi.com).

From North America, call 888.988.ITAR.

From the rest of the world, call 650.318.4900.



**Microsemi Corporate Headquarters**  
One Enterprise, Aliso Viejo CA 92656 USA  
Within the USA: +1 (949) 380-6100  
Sales: +1 (949) 380-6136  
Fax: +1 (949) 215-4996

Microsemi Corporation (NASDAQ: MSCC) offers a comprehensive portfolio of semiconductor solutions for: aerospace, defense and security; enterprise and communications; and industrial and alternative energy markets. Products include high-performance, high-reliability analog and RF devices, mixed signal and RF integrated circuits, customizable SoCs, FPGAs, and complete subsystems. Microsemi is headquartered in Aliso Viejo, Calif. Learn more at [www.microsemi.com](http://www.microsemi.com).

© 2013 Microsemi Corporation. All rights reserved. Microsemi and the Microsemi logo are trademarks of Microsemi Corporation. All other trademarks and service marks are the property of their respective owners.



## Стандарт Электрон Связь

Мы молодая и активно развивающаяся компания в области поставок электронных компонентов. Мы поставляем электронные компоненты отечественного и импортного производства напрямую от производителей и с крупнейших складов мира.

Благодаря сотрудничеству с мировыми поставщиками мы осуществляем комплексные и плановые поставки широчайшего спектра электронных компонентов.

Собственная эффективная логистика и склад в обеспечивает надежную поставку продукции в точно указанные сроки по всей России.

Мы осуществляем техническую поддержку нашим клиентам и предпродажную проверку качества продукции. На все поставляемые продукты мы предоставляем гарантию .

Осуществляем поставки продукции под контролем ВП МО РФ на предприятия военно-промышленного комплекса России , а также работаем в рамках 275 ФЗ с открытием отдельных счетов в уполномоченном банке. Система менеджмента качества компании соответствует требованиям ГОСТ ISO 9001.

Минимальные сроки поставки, гибкие цены, неограниченный ассортимент и индивидуальный подход к клиентам являются основой для выстраивания долгосрочного и эффективного сотрудничества с предприятиями радиоэлектронной промышленности, предприятиями ВПК и научно-исследовательскими институтами России.

С нами вы становитесь еще успешнее!

### Наши контакты:

**Телефон:** +7 812 627 14 35

**Электронная почта:** [sales@st-electron.ru](mailto:sales@st-electron.ru)

**Адрес:** 198099, Санкт-Петербург,  
Промышленная ул, дом № 19, литера Н,  
помещение 100-Н Офис 331