

# TPS657051/2EVM-522 Evaluation Module

This user's guide describes the characteristics, operation, and use of the TPS657051/2EVM evaluation module (EVM). The EVM is designed to help the user easily evaluate and test the operation and functionality of the TPS657051/2. This user's guide includes setup instructions for the hardware, a schematic diagram, a bill of materials, and printed-circuit board layout drawings for the evaluation module.

## Contents

1	Introduction .....	1
1.1	Requirements .....	1
1.2	Power Supply Requirements .....	2
1.3	Applications .....	2
1.4	Features .....	2
2	TPS657051/2EVM Electrical Performance Specifications .....	2
3	TPS657051/2EVM Schematic .....	3
4	Connector and Test Point Descriptions .....	4
4.1	Input/Output Connectors .....	4
4.2	Enable Jumpers and Switches .....	5
5	Setup .....	6
5.1	Hardware Setup .....	6
6	TPS657051/2EVM Assembly Drawings and Layout .....	7
7	Bill of Materials .....	10

## List of Figures

1	TPS657051/2EVM Schematic.....	3
2	Hardware Board Connection .....	6
3	TPS657051/2EVM Component Placement, Viewed From Top.....	7
4	TPS657051/2EVM Silkscreen Top, X-Ray View .....	7
5	TPS657051/2EVM Top Copper, Viewed From Top .....	8
6	TPS657051/2EVM Internal 1, X-Ray View .....	8
7	TPS657051/2EVM Internal 2, X-Ray View From Top.....	9
8	TPS657051/2EVM Bottom Copper View, X-Ray View From Top .....	9

## List of Tables

1	TPS657051/2EVM Electrical and Performance Specifications .....	2
2	HPA522A Bill of Materials .....	10

## 1 Introduction

The TPS657051/2EVM-522 evaluation module is a fully assembled and tested circuit for evaluating the TPS657051/2 3-channel power management integrated circuit (IC).

### 1.1 Requirements

In order to operate this evaluation module (EVM), the following components must be connected and properly configured. All components and connectors are supplied in the EVM DC power supply.

## 1.2 Power Supply Requirements

A dc power supply capable of delivering 5 V at 1 A is required to operate this EVM

## 1.3 Applications

- USB camera
- Handheld applications

## 1.4 Features

- Input voltage rating
- 2 x 200-mA Step-down converter for TPS657051/2
- 2.25-MHz switching frequency
- 1 General-purpose 200-mA LDO

## 2 TPS657051/2EVM Electrical Performance Specifications

**Table 1. TPS657051/2EVM Electrical and Performance Specifications**

Parameter	Notes and Conditions	Min	Typ	Max	Unit	
<b>INPUT CHARACTERISTICS</b>						
V <sub>IN</sub>	Input Voltage	3.3		6	V	
V <sub>IN1</sub>	Input Voltage DCDC1	3.3		6	V	
V <sub>IN2</sub>	Input Voltage LDO1	3.3		6	V	
V <sub>UVLO</sub>	UVLO	V <sub>AC</sub> rising	3.2	3.3	3.45	V
V <sub>HYS -UVLO</sub>	UVLO Hysteresis	V <sub>AC</sub> falling	200		300	mV
<b>OUTPUT CHARACTERISTICS</b>						
V <sub>DCDC1</sub>	Output Voltage DCDC1	V <sub>IN</sub> = Nom, I <sub>OUT</sub> = Nom		3.3	V	
V <sub>DCDC2</sub>	Output Voltage DCDC2	V <sub>IN</sub> = Nom, I <sub>OUT</sub> = Nom		1.8	V	
V <sub>LDO1</sub>	Output Voltage LDO1	V <sub>IN</sub> = Nom, I <sub>OUT</sub> = Nom	TPS657051	3.0	V	
			TPS657052	2.8		
	Output Voltage Accuracy DCDC1, DCDC2	V <sub>IN</sub> = 3.3 V to 6 V, PFM Mode, Load 0 mA to I <sub>out</sub> , max		-1.5 %	1.5 %	
	Output Voltage Accuracy LDO1	I <sub>OUT</sub> = 100 mA, V <sub>out</sub> = 2.8 V		1	3	
	Dropout Voltage at LDO	I <sub>O</sub> = 200 mA		-2%	+2%	
	Dropout Voltage at LDO	I <sub>O</sub> = 200 mA			200	mV
I <sub>OUT1</sub>	Output Current DCDC1	V <sub>IN</sub> = Min to Max		400	mA	
I <sub>OUT2</sub>	Output Current DCDC2	V <sub>IN</sub> = Min to Max		400	mA	
I <sub>OUT1</sub>	Output Current LDO1	V <sub>IN</sub> = Min to Max		200	mA	
<b>SYSTEMS CHARACTERISTICS</b>						
F <sub>SW</sub>	Switching Frequency		2030	2250	2480	kHz
η <sub>pk</sub>	Peak Efficiency	V <sub>IN</sub> = Nom		-	92%	

### 3 TPS657051/2EVM Schematic

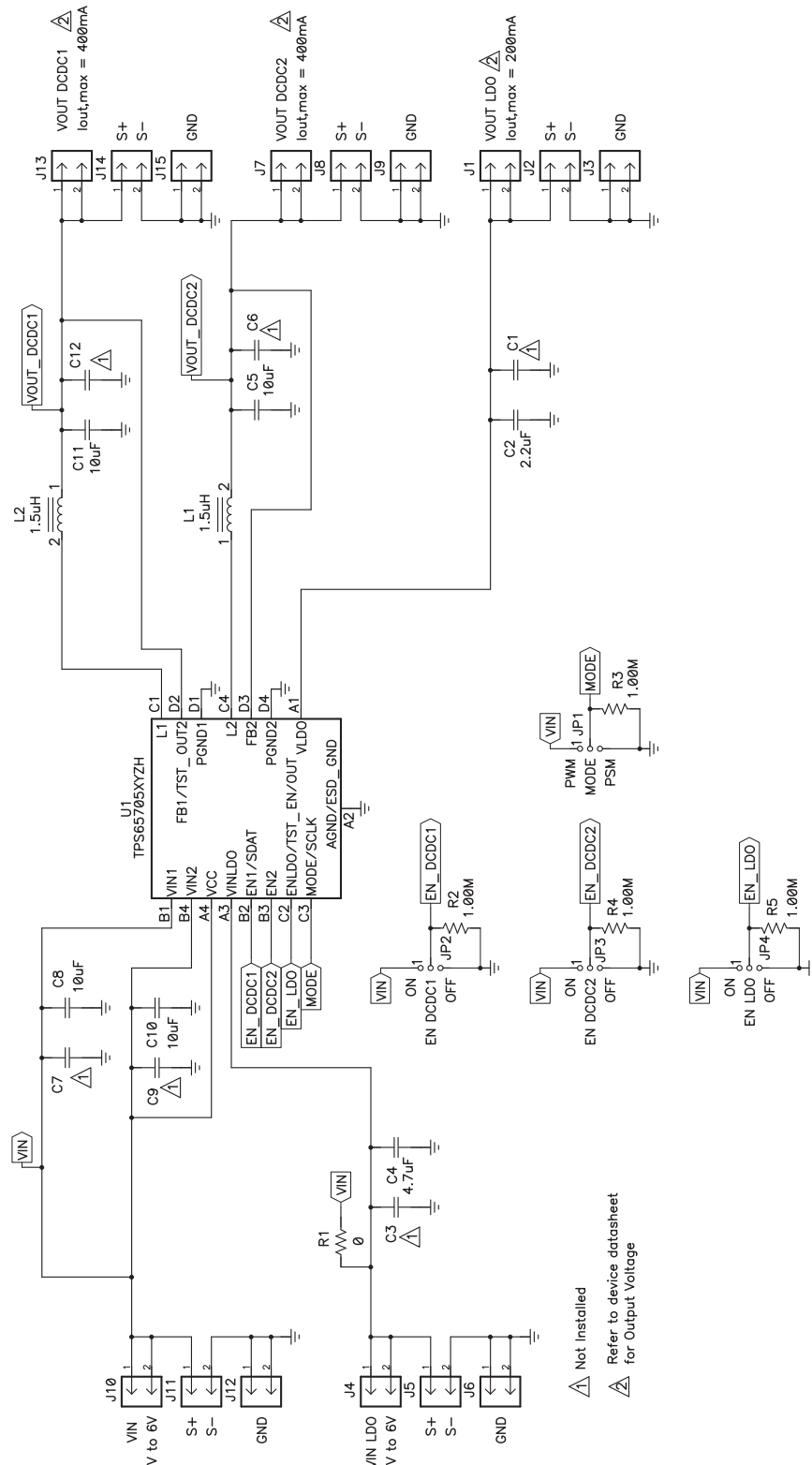

For Reference Only, See [Table 2](#) Bill of Materials for Specific Values

**Figure 1. TPS657051/2EVM Schematic**

## 4 Connector and Test Point Descriptions

### 4.1 Input/Output Connectors

#### 4.1.1 J1 – VLDO

This header is the positive output of the low-dropout (LDO) linear regulator. The default output voltage of the LDO is 3 V (TPS657051) and 2.8 V (TPS657052). The LDO is capable of sourcing up to 200-mA. A load can be connected between J1 and J3 (GND).

This header is the positive connection to the input power supply. The power supply must be connected between J1 and J2 (GND). Twist the leads to the input supply, and keep them as short as possible. The input voltage has to be between 4.35 V and 6 V.

#### 4.1.2 J2 – S+/S–

J2 S+/S– is the sense connection for the output of the LDO. Connect a voltmeter, sense connection of an electronic load, or oscilloscope to this header.

#### 4.1.3 J3 – GND

J3 is the return connection of the LDO. A load can be connected between J3 and J1 (VLDO).

#### 4.1.4 J4 – VINLDO

This header is the input supply for the LDO on the EVM VINLDO and is directly connected to VIN with R1. An external power supply can be connected between J4 (VINLDO) and J6 (GND). Note that the resistors R1 must be removed when supplying the LDO from an external power supply.

#### 4.1.5 J5 – S+/S–

J5 S+/S– is the sense connection for the input power supply of the LDO. Connect a voltmeter, sense connection of a power supply, or oscilloscope to this header.

#### 4.1.6 J6 – GND

J6 is the return connection of the input power supply for the LDO on the EVM. The input of the LDO is directly connected to VIN with R1. Connect an input power supply of the LDO between J4 (VINLDO) and J6.

#### 4.1.7 J7 – VOUT DCDC2

This header is the positive output of VDCDC2 step-down converter. The output voltage of DCDC2 is fixed to 1.8 V from the TPS657051 and TPS657052.

VDCDC2 is capable of sourcing up to 400 mA. A load can be connected between J7 and J9 (GND).

#### 4.1.8 J8 – S+/S–

J8 S+/S– are the sense connection for the output of DCDC2. Connect a voltmeter, sense connection of an electronic load, or oscilloscope to this header.

#### 4.1.9 J9 – GND

J8 is the return connection of VDCDC2 output rail. A load can be connected between J9 and J7 (VDCDC2).

#### 4.1.10 J4 – VIN

This header is the input supply for the dc/dc converters. Connect a power supply between J12 (GND) and J10.

#### 4.1.11 J11 – S+/S–

J11 S+/S– is the sense connection for the input power supply of the dc/dc converters. Connect a voltmeter, sense connection of a power supply or oscilloscope to this header.

#### 4.1.12 J12 – GND

J12 is the return connection of the input power supply of the dc/dc converters. Connect a power supply between J10 (VIN) and J12.

#### 4.1.13 J13 – VOUT DCDC1

This header is the positive output of VDCDC1 step-down converter. The output voltage of DCDC1 is fixed to 3 V (TPS657051) and 2.8 V (TPS657052).

VDCDC1 is capable of sourcing up to 400 mA. A load can be connected between J15 (GND) and J13.

#### 4.1.14 J14 S+/S–

J14 S+/S– are the sense connection for the output of DCDC1. Connect a voltmeter, sense connection of an electronic load, or oscilloscope to this header.

#### 4.1.15 GND

J8 is the return connection of VDCDC2 output rail. A load can be connected between J13 (VOUT DCDC1) and J15.

## 4.2 Enable Jumpers and Switches

### 4.2.1 JP1 MODE

JP1 selects the forced PWM or Power Save Mode (PSM) operation for the DC/DC converters. Placing a shorting bar between MODE and PWM ties the MODE pin of TPS655051/2 to VIN, thereby selecting forced PWM operating mode for the DC/DC converters. Placing a shorting bar between MODE and PFM ties the MODE pin of TPS657051/2 to GND, thereby selecting Power Save Mode operating mode for the DC/DC converter at light-load conditions. If Power Save mode is selected, the DC/DC converters automatically switch to PWM mode at heavier load conditions.

### 4.2.2 JP2 EN\_DCDC1

Placing a shorting bar between EN\_DCDC1 and ON ties the enable pin of the DC/DC converter to VIN, thereby enabling the DCDC1. Placing a shorting bar between EN\_DCDC1 and OFF ties the enable pin of the DC/DC converter to GND, thereby disabling the DCDC1.

### 4.2.3 JP2 EN\_DCDC1

Placing a shorting bar between EN\_DCDC2 and ON ties the enable pin of the DC/DC converter to VIN, thereby enabling the DCDC2. Placing a shorting bar between EN\_DCDC2 and OFF ties the enable pin of the DC/DC converter to GND, thereby disabling the DCDC2

### 4.2.4 JP4 EN\_LDO

Placing a shorting bar between EN\_LDO and ON ties the enable pin of the LDO to VIN, thereby enabling the LDO. Placing a shorting bar between EN\_LDO and OFF ties the enable pin of the LDO to GND, thereby disabling the LDO.

## 5 Setup

### 5.1 Hardware Setup

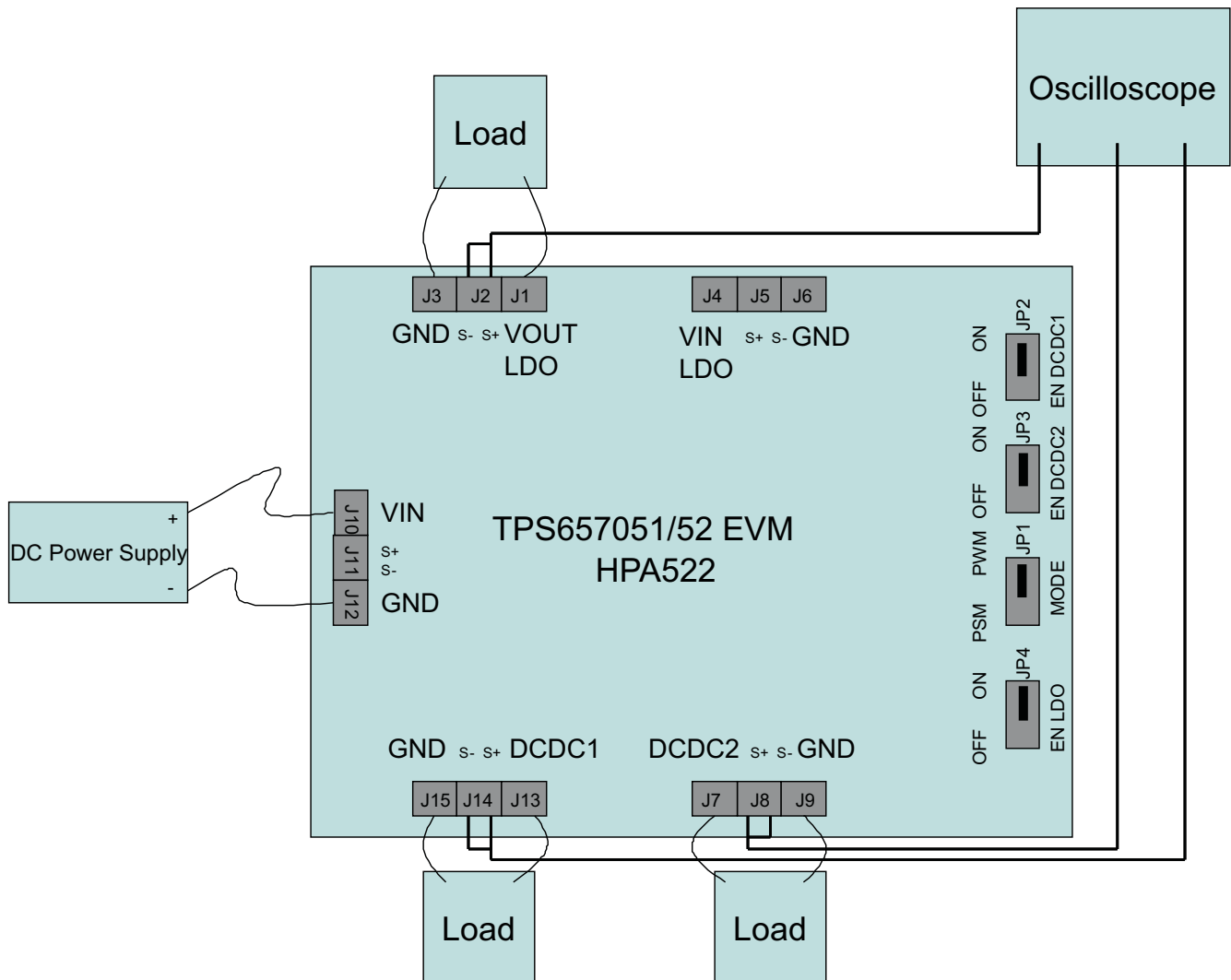

Figure 2. Hardware Board Connection

## 6 TPS657051/2EVM Assembly Drawings and Layout

The following illustrations (Figure 3 through Figure 4) show the design of the TPS657051/2EVM printed-circuit board.

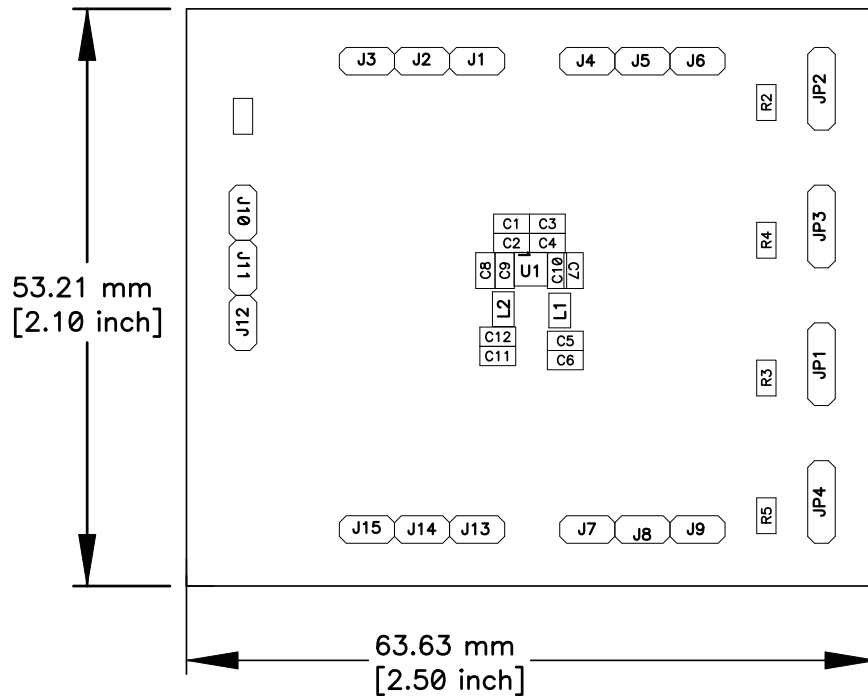

Figure 3. TPS657051/2EVM Component Placement, Viewed From Top

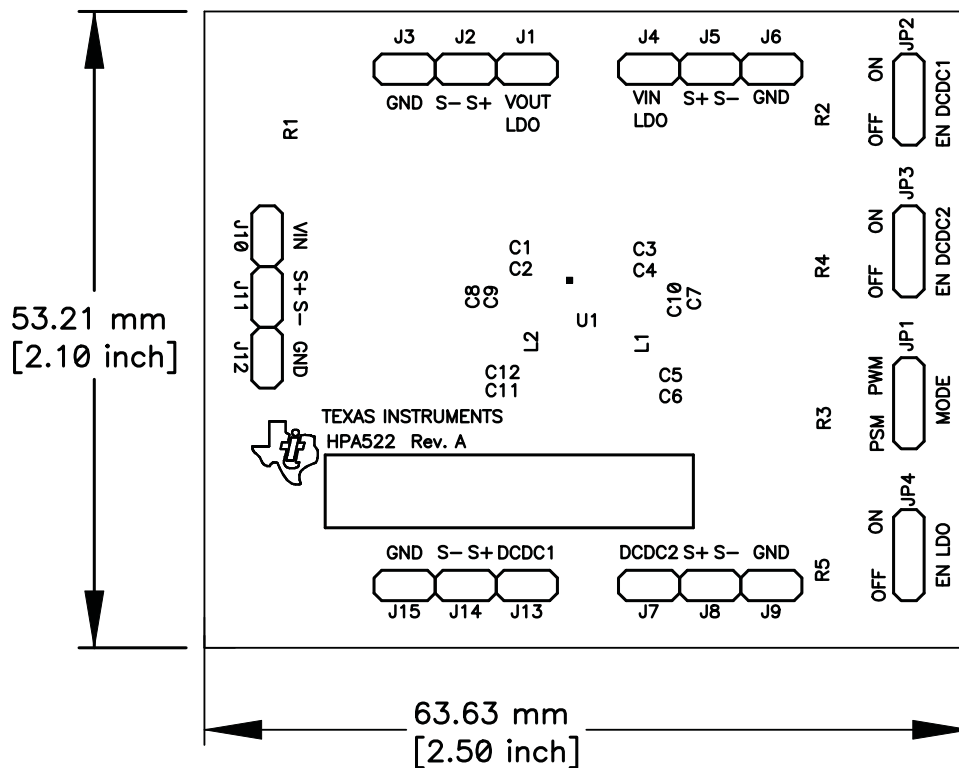

Figure 4. TPS657051/2EVM Silkscreen Top, X-Ray View

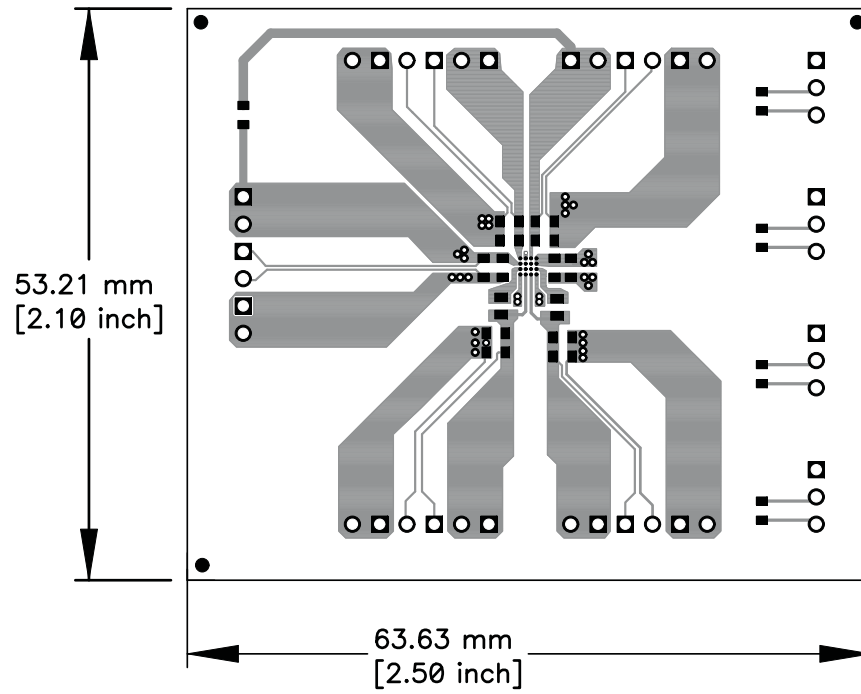

Figure 5. TPS657051/2EVM Top Copper, Viewed From Top

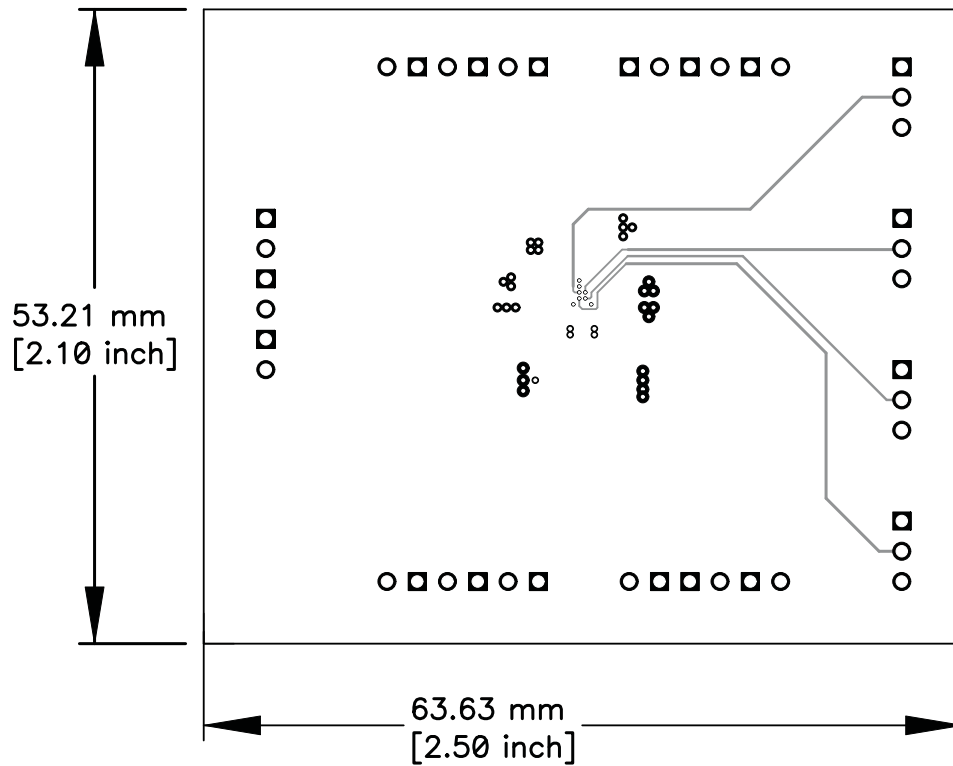

Figure 6. TPS657051/2EVM Internal 1, X-Ray View



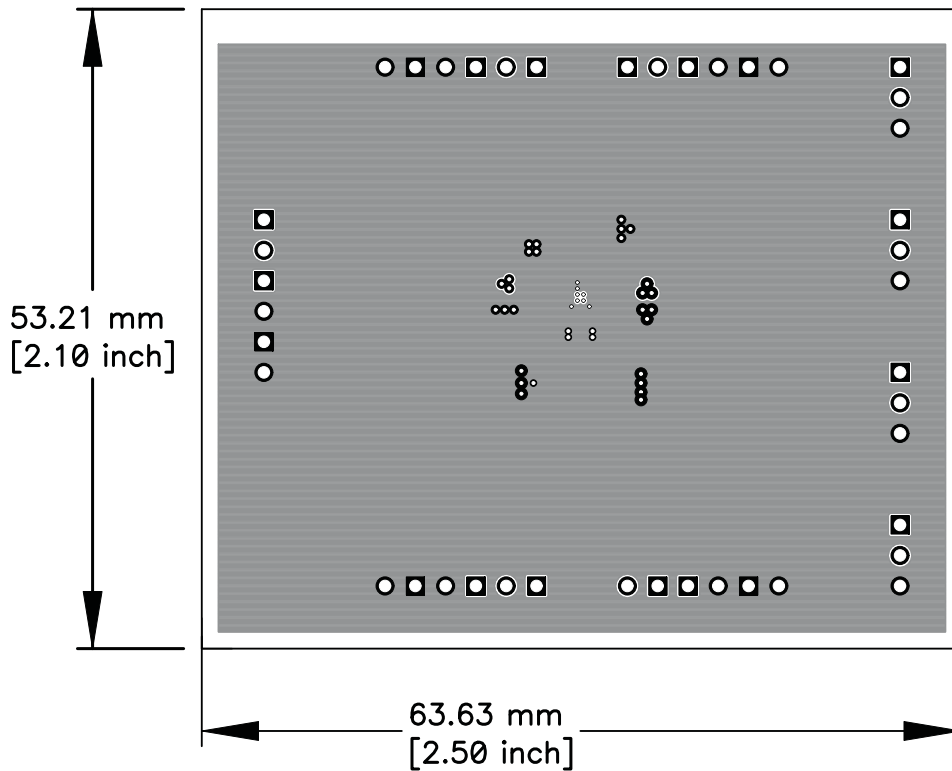

Figure 7. TPS657051/2EVM Internal 2, X-Ray View From Top

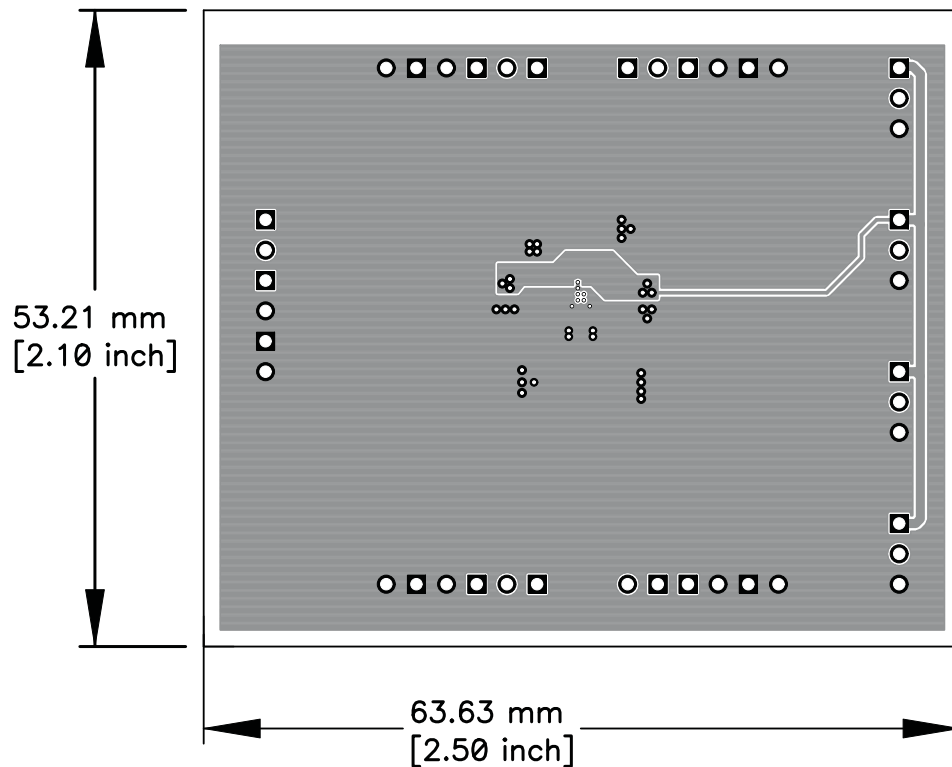

Figure 8. TPS657051/2EVM Bottom Copper View, X-Ray View From Top

## 7 Bill of Materials

**Table 2. HPA522A Bill of Materials**

Count		RefDes	Value	Description	Size	Part Number	MFR
-001	-002						
0	0	C1	open	Capacitor, Ceramic, 6.3V, X5R, 10%	0603	Std	Std
1	1	C2	2.2 $\mu$ F	Capacitor, Ceramic, 6.3V, X5R, 10%	0603	GRM188R60J225KE19D	Murata
0	0	C3, C6, C7, C9, C12	open	Capacitor, Ceramic, 6.3V, X5R, 20%	0603	Std	Std
1	1	C4	4.7 $\mu$ F	Capacitor, Ceramic, 6.3V, X5R, 10%	0603	GRM188R60J475KE19D	Murata
4	4	C5, C8, C10, C11	10 $\mu$ F	Capacitor, Ceramic, 6.3V, X5R, 20%	0603	GRM188R60J106ME47D	Murata
2	2	L1, L2	1.5 $\mu$ H	Inductor, 700 mA, 300 m $\Omega$	1608	BRC1608T1R5M	Taiyo Yuden
1	1	R1	0	Resistor, Chip, 1/16W, 1%	0603	Std	Std
4	4	R2–R5	1.00M	Resistor, Chip, 1/16W, 1%	0603	Std	Std
1	0	U1	TPS657051YZH	IC, Power Management Unit fro Embedded Camera Module	DSBGA-16	TPS657051YZH	TI
0	1	U1	TPS657052YZH	IC, Power Management Unit fro Embedded Camera Module	DSBGA-16	TPS657052YZH	TI
1	1	–		PCB, 2.5 In x 2.1 In x 0.062 In		HPA522	Any

## Evaluation Board/Kit Important Notice

Texas Instruments (TI) provides the enclosed product(s) under the following conditions:

This evaluation board/kit is intended for use for **ENGINEERING DEVELOPMENT, DEMONSTRATION, OR EVALUATION PURPOSES ONLY** and is not considered by TI to be a finished end-product fit for general consumer use. Persons handling the product(s) must have electronics training and observe good engineering practice standards. As such, the goods being provided are not intended to be complete in terms of required design-, marketing-, and/or manufacturing-related protective considerations, including product safety and environmental measures typically found in end products that incorporate such semiconductor components or circuit boards. This evaluation board/kit does not fall within the scope of the European Union directives regarding electromagnetic compatibility, restricted substances (RoHS), recycling (WEEE), FCC, CE or UL, and therefore may not meet the technical requirements of these directives or other related directives.

Should this evaluation board/kit not meet the specifications indicated in the User's Guide, the board/kit may be returned within 30 days from the date of delivery for a full refund. **THE FOREGOING WARRANTY IS THE EXCLUSIVE WARRANTY MADE BY SELLER TO BUYER AND IS IN LIEU OF ALL OTHER WARRANTIES, EXPRESSED, IMPLIED, OR STATUTORY, INCLUDING ANY WARRANTY OF MERCHANTABILITY OR FITNESS FOR ANY PARTICULAR PURPOSE.**

The user assumes all responsibility and liability for proper and safe handling of the goods. Further, the user indemnifies TI from all claims arising from the handling or use of the goods. Due to the open construction of the product, it is the user's responsibility to take any and all appropriate precautions with regard to electrostatic discharge.

**EXCEPT TO THE EXTENT OF THE INDEMNITY SET FORTH ABOVE, NEITHER PARTY SHALL BE LIABLE TO THE OTHER FOR ANY INDIRECT, SPECIAL, INCIDENTAL, OR CONSEQUENTIAL DAMAGES.**

TI currently deals with a variety of customers for products, and therefore our arrangement with the user **is not exclusive.**

TI assumes **no liability for applications assistance, customer product design, software performance, or infringement of patents or services described herein.**

Please read the User's Guide and, specifically, the Warnings and Restrictions notice in the User's Guide prior to handling the product. This notice contains important safety information about temperatures and voltages. For additional information on TI's environmental and/or safety programs, please contact the TI application engineer or visit [www.ti.com/esh](http://www.ti.com/esh).

No license is granted under any patent right or other intellectual property right of TI covering or relating to any machine, process, or combination in which such TI products or services might be or are used.

## FCC Warning

This evaluation board/kit is intended for use for **ENGINEERING DEVELOPMENT, DEMONSTRATION, OR EVALUATION PURPOSES ONLY** and is not considered by TI to be a finished end-product fit for general consumer use. It generates, uses, and can radiate radio frequency energy and has not been tested for compliance with the limits of computing devices pursuant to part 15 of FCC rules, which are designed to provide reasonable protection against radio frequency interference. Operation of this equipment in other environments may cause interference with radio communications, in which case the user at his own expense will be required to take whatever measures may be required to correct this interference.

## EVM Warnings and Restrictions

It is important to operate this EVM within the input voltage range of 3.3 V to 6 V and the output voltage range of 1.2 V to 3 V .

Exceeding the specified input range may cause unexpected operation and/or irreversible damage to the EVM. If there are questions concerning the input range, please contact a TI field representative prior to connecting the input power.

Applying loads outside of the specified output range may result in unintended operation and/or possible permanent damage to the EVM. Please consult the EVM User's Guide prior to connecting any load to the EVM output. If there is uncertainty as to the load specification, please contact a TI field representative.

During normal operation, some circuit components may have case temperatures greater than 60° C. The EVM is designed to operate properly with certain components above 60° C as long as the input and output ranges are maintained. These components include but are not limited to linear regulators, switching transistors, pass transistors, and current sense resistors. These types of devices can be identified using the EVM schematic located in the EVM User's Guide. When placing measurement probes near these devices during operation, please be aware that these devices may be very warm to the touch.

Mailing Address: Texas Instruments, Post Office Box 655303, Dallas, Texas 75265  
Copyright © 2010, Texas Instruments Incorporated

## IMPORTANT NOTICE

Texas Instruments Incorporated and its subsidiaries (TI) reserve the right to make corrections, modifications, enhancements, improvements, and other changes to its products and services at any time and to discontinue any product or service without notice. Customers should obtain the latest relevant information before placing orders and should verify that such information is current and complete. All products are sold subject to TI's terms and conditions of sale supplied at the time of order acknowledgment.

TI warrants performance of its hardware products to the specifications applicable at the time of sale in accordance with TI's standard warranty. Testing and other quality control techniques are used to the extent TI deems necessary to support this warranty. Except where mandated by government requirements, testing of all parameters of each product is not necessarily performed.

TI assumes no liability for applications assistance or customer product design. Customers are responsible for their products and applications using TI components. To minimize the risks associated with customer products and applications, customers should provide adequate design and operating safeguards.

TI does not warrant or represent that any license, either express or implied, is granted under any TI patent right, copyright, mask work right, or other TI intellectual property right relating to any combination, machine, or process in which TI products or services are used. Information published by TI regarding third-party products or services does not constitute a license from TI to use such products or services or a warranty or endorsement thereof. Use of such information may require a license from a third party under the patents or other intellectual property of the third party, or a license from TI under the patents or other intellectual property of TI.

Reproduction of TI information in TI data books or data sheets is permissible only if reproduction is without alteration and is accompanied by all associated warranties, conditions, limitations, and notices. Reproduction of this information with alteration is an unfair and deceptive business practice. TI is not responsible or liable for such altered documentation. Information of third parties may be subject to additional restrictions.

Resale of TI products or services with statements different from or beyond the parameters stated by TI for that product or service voids all express and any implied warranties for the associated TI product or service and is an unfair and deceptive business practice. TI is not responsible or liable for any such statements.

TI products are not authorized for use in safety-critical applications (such as life support) where a failure of the TI product would reasonably be expected to cause severe personal injury or death, unless officers of the parties have executed an agreement specifically governing such use. Buyers represent that they have all necessary expertise in the safety and regulatory ramifications of their applications, and acknowledge and agree that they are solely responsible for all legal, regulatory and safety-related requirements concerning their products and any use of TI products in such safety-critical applications, notwithstanding any applications-related information or support that may be provided by TI. Further, Buyers must fully indemnify TI and its representatives against any damages arising out of the use of TI products in such safety-critical applications.

TI products are neither designed nor intended for use in military/aerospace applications or environments unless the TI products are specifically designated by TI as military-grade or "enhanced plastic." Only products designated by TI as military-grade meet military specifications. Buyers acknowledge and agree that any such use of TI products which TI has not designated as military-grade is solely at the Buyer's risk, and that they are solely responsible for compliance with all legal and regulatory requirements in connection with such use.

TI products are neither designed nor intended for use in automotive applications or environments unless the specific TI products are designated by TI as compliant with ISO/TS 16949 requirements. Buyers acknowledge and agree that, if they use any non-designated products in automotive applications, TI will not be responsible for any failure to meet such requirements.

Following are URLs where you can obtain information on other Texas Instruments products and application solutions:

<b>Products</b>		<b>Applications</b>	
Amplifiers	<a href="http://amplifier.ti.com">amplifier.ti.com</a>	Audio	<a href="http://www.ti.com/audio">www.ti.com/audio</a>
Data Converters	<a href="http://dataconverter.ti.com">dataconverter.ti.com</a>	Automotive	<a href="http://www.ti.com/automotive">www.ti.com/automotive</a>
DLP® Products	<a href="http://www.dlp.com">www.dlp.com</a>	Communications and Telecom	<a href="http://www.ti.com/communications">www.ti.com/communications</a>
DSP	<a href="http://dsp.ti.com">dsp.ti.com</a>	Computers and Peripherals	<a href="http://www.ti.com/computers">www.ti.com/computers</a>
Clocks and Timers	<a href="http://www.ti.com/clocks">www.ti.com/clocks</a>	Consumer Electronics	<a href="http://www.ti.com/consumer-apps">www.ti.com/consumer-apps</a>
Interface	<a href="http://interface.ti.com">interface.ti.com</a>	Energy	<a href="http://www.ti.com/energy">www.ti.com/energy</a>
Logic	<a href="http://logic.ti.com">logic.ti.com</a>	Industrial	<a href="http://www.ti.com/industrial">www.ti.com/industrial</a>
Power Mgmt	<a href="http://power.ti.com">power.ti.com</a>	Medical	<a href="http://www.ti.com/medical">www.ti.com/medical</a>
Microcontrollers	<a href="http://microcontroller.ti.com">microcontroller.ti.com</a>	Security	<a href="http://www.ti.com/security">www.ti.com/security</a>
RFID	<a href="http://www.ti-rfid.com">www.ti-rfid.com</a>	Space, Avionics & Defense	<a href="http://www.ti.com/space-avionics-defense">www.ti.com/space-avionics-defense</a>
RF/IF and ZigBee® Solutions	<a href="http://www.ti.com/lprf">www.ti.com/lprf</a>	Video and Imaging	<a href="http://www.ti.com/video">www.ti.com/video</a>
		Wireless	<a href="http://www.ti.com/wireless-apps">www.ti.com/wireless-apps</a>

Mailing Address: Texas Instruments, Post Office Box 655303, Dallas, Texas 75265  
Copyright © 2010, Texas Instruments Incorporated



## Стандарт Электрон Связь

Мы молодая и активно развивающаяся компания в области поставок электронных компонентов. Мы поставляем электронные компоненты отечественного и импортного производства напрямую от производителей и с крупнейших складов мира.

Благодаря сотрудничеству с мировыми поставщиками мы осуществляем комплексные и плановые поставки широчайшего спектра электронных компонентов.

Собственная эффективная логистика и склад в обеспечивает надежную поставку продукции в точно указанные сроки по всей России.

Мы осуществляем техническую поддержку нашим клиентам и предпродажную проверку качества продукции. На все поставляемые продукты мы предоставляем гарантию .

Осуществляем поставки продукции под контролем ВП МО РФ на предприятия военно-промышленного комплекса России , а также работаем в рамках 275 ФЗ с открытием отдельных счетов в уполномоченном банке. Система менеджмента качества компании соответствует требованиям ГОСТ ISO 9001.

Минимальные сроки поставки, гибкие цены, неограниченный ассортимент и индивидуальный подход к клиентам являются основой для выстраивания долгосрочного и эффективного сотрудничества с предприятиями радиоэлектронной промышленности, предприятиями ВПК и научно-исследовательскими институтами России.

С нами вы становитесь еще успешнее!

### Наши контакты:

**Телефон:** +7 812 627 14 35

**Электронная почта:** [sales@st-electron.ru](mailto:sales@st-electron.ru)

**Адрес:** 198099, Санкт-Петербург,  
Промышленная ул, дом № 19, литера Н,  
помещение 100-Н Офис 331